

Biosecurity, Infection Control, and Continuity of Dairy Operations in FMD Response: A New England Perspective

by

Richard P. Horwitz, Ph.D.
Consultant

Prepared for the
United States Department of Agriculture,
Animal and Plant Health Inspection Service (USDA-APHIS)
and
the New England Animal Agricultural Security Alliance (NESAASA)
under
Cooperative Agreement Number 14-9744-1245CA (FFY 2014)

August 1, 2015

CONTENTS and Figures

SUMMARY	4
STAKES: The Difference in the New England SMS Plan	5
Dairy Farms in New England by Minimum Readiness Rating	6
BACKGROUND: Foot-and-Mouth Disease as a Hazard	7
Reservoirs of Foot-and-Mouth Disease Virus	8
FMD-Free Nations, 2014	8
PRIORITIES IN FMD RESPONSE	9
Example of Defining and Adjusting a Control Area to Contain Infection	9
SMS OBJECTIVES: Disease Control and Business Continuity	11
Biosecurity Objectives, Benchmarks and Risks in Permitting Milk Movement	12
SMS STRATEGY: The Sweet Spot	12
Food Traceability, Farm-to-Fork and Cow-to-Consumer	13
A NEW ENGLAND DAIRY PERSPECTIVE	14
Sample Layout of a Dairy Farm and Biosecurity Zones	15
Sample Layout of Poultry and Hog Farm Biosecurity and a Plant Truck Wash	16
States and Farms with Confirmed HPAI, 2014-2015	17
States and Farms with Confirmed PEDV, 2014-2015	17
Sanitation, Feasibility, and Flexibility in Farm Biosecurity	18
Readiness to Clean Vehicles at Dairy Farm Gates in New England	19
LIMITATIONS IN “SCIENCE-BASED” EMERGENCY MANAGEMENT	20
LIMITATIONS IN “SCIENCE-BASED” MANAGEMENT OF FMDV	22
Experiments, Models, and Estimates of FMD Transmission	23
LESSONS FROM INFECTION CONTROL IN HUMAN HEALTHCARE SETTINGS	25
DEVELOP CONFIDENCE-GRADED TACTICS	26
Grading Evidence of Effectiveness and Recommendations for Healthcare	27
GRADE Process	29
CDC Categories in Recommending Infection-Control Practices	29
FAVOR TACTICS WITH PROVEN HEALTH BENEFITS	29
Confidence in Practical, Important Outcomes: GRADE Training Slides	30
Spaulding Classification System	32
Processing Required for Microorganisms as Their Resistance Decreases	32
Redundancy and Fallibility in Biosecurity	33
Environmental Contamination: Examples from Hospital Studies, 2012	34
Gaps in Research to Support HAI Control	35
Pathogen Detection, C&D, and Disease Transmission	37

ADJUST TACTICS AS RETURNS DIMINISH	38
Effort, Results, and the Point of Diminishing Returns	38
Pareto Principle: The 80/20 Rule	39
TRAINING AND OVERSIGHT OF PEOPLE WHO CLEAN AND DISINFECT	39
Thoroughness of Cleaning in Hospitals	40
Evaluating Patient-Zone Environmental Cleaning: Exemplary Methods and Benefits.....	41
USE OF APPROVED CONTACT TIMES FOR DISINFECTANTS	41
Contact Time for Disinfectants in Practical Applications	44
USE OF DISINFECTANT ON ENVIRONMENTAL SURFACES	44
Disinfectant versus Detergent in Cleaning Floors of Healthcare Facilities	45
Clinical Outcomes of Environmental Disinfection in Hospitals	47
Consequences of the Use of Disinfectant to Lower Microbial Loads	48
IMPLICATIONS FOR FARM BIOSECURITY AND SMS PLANNING	49
Risk of FMD Spread by Milk Tankers	49
Challenge of Decontamination of Farm Vehicles in an Outbreak.....	50
Pragmatism and Flexibility in Biosecurity	51
REFERENCES	53

SUMMARY

This report is an analysis of ways to sustain dairy operations in the event of an outbreak of Foot-and-Mouth Disease (FMD), particularly the biosecurity requirements for allowing farms to ship milk to processors. It features a justification of aspects of the [New England Secure Milk Supply Plan](#) that differ from other SMS plans in the U.S. A key difference is an emphasis on requirements that are feasible and flexible.

The goal of FMD response (return to disease-free status) entails a pair of related but distinct objectives: disease control and business continuity. Although allied in theory, these objectives are apt to conflict in the most likely sort of outbreak. Biosecurity prerequisites for “managed” milk movement could well be too strict or too lax, depending on the severity of the outbreak and the resources available. Tactics should be ready to target the shifting sweet spot between these ends, optimally both exacting and achievable, given conditions on the ground at the time. More stringent, fixed requirements (e.g., for “pre-certification” as featured in most current U.S. Secure Food Supply plans) may yield rewards in the long-term, but in the meantime – at least for dairy-oriented, small-farm states – they may be more destructive of agriculture, the food supply, and the environment than the disease itself.

Dairy farmers may not be faulted for being slow to embrace precautions that recently so failed to protect the “best” of poultry and pork producers from deadly disease. Dairying lags far behind them in biosecurity capacity, and great, albeit reduced vulnerability to infection seems certain to remain, no matter what they do. Preparations for FMD can and should be responsive to the specific threat at the time and the actual capacity of regulators and producers to meet the benchmarks that permitting procedures require. In privileging both business continuity and disease control, more agile and pragmatic requirements like those developed in New England may actually better protect agriculture, animal welfare, the food supply, and the environment.

The “science” invoked to credit more exacting biosecurity measures has important limitations. Estimates of their feasibility, costs and benefits have never been well proven. The research has been inherently limited and biased to stress hazards and remedies for control of microbes over disease or business continuity. There is little empirical evidence that more stringent tactics for controlling an outbreak (e.g., cleaning and disinfection regimens designed for prior crises in other regions) will be sufficient, workable, or worth it in the next animal-disease emergency.

The limits of that science have been well demonstrated and documented in attempts to control infection in human-healthcare settings. Despite greater incentives and capacity, analogous efforts to protect patients from Healthcare Associated Infections (HAI) – like efforts to protect livestock from FMD, HPAI, and PED – have been disappointing. Among the lessons of that experience has been the need to develop confidence-graded tactics, favoring those with proven health benefits, and readiness to shift tactics as returns diminish. Application of such principles casts doubt on the likely efficacy of several tactics that are featured in Secure Food Supply plans, in particular: formal programs for training and certification of people who clean and disinfect, long dwell times for disinfectants, and the preference for disinfectant (over detergent alone) in reducing environmental sources of contagion. In fact, a major lesson of the past couple of decades has been to shift the focus of remediation from indirect to direct transmission, from environmental microbicide to simple standard precautions. Since more stringent controls so often prove short of feasible and beneficial, there is little reason to mandate them, come what may.

Such research and experience bodes well for more pragmatic and flexible alternatives like those being developed in New England.

STAKES: The Difference in the New England SMS Plan

This report is an analysis of ways to sustain dairy operations in the event of an outbreak of Foot-and-Mouth Disease (FMD), particularly the biosecurity requirements for continued movement of milk from farms to processors. It features a justification of aspects of the [New England Secure Milk Supply \(SMS\) Plan](#) that differ from SMS plans developing elsewhere in the U.S.¹

The difference is more a matter of tactics than approach. New England joins the rest of the United States in compliance with the DHS-FEMA [National Response Framework](#) (NRF) and [National Incident Management System](#) (NIMS), the USDA-APHIS [Red Book](#), and Secure Milk Supply (SMS) [Biosecurity Performance Standards](#). These plans and policies invite states, tribes, and regions not only to share common goals, objectives, and strategies but also to develop tactics that are tailored to local needs. New England is well advanced in that process.²

New England SMS tactics chiefly differ (e.g., when compared to current draft plans for California and Mid-Atlantic States) in emphasizing flexibility in permitting milk movement. Plainly, within any FMD Control Area, measures to prevent the spread of contamination must be in place before shipments can be permitted. Using information about existing biosecurity and production capabilities, New England requirements can be both precise and adjustable, with readily anticipated consequences. These preparations allow Incident Command in mere minutes to fine-tune permitting prerequisites to serve regional dairies as they exist in the near term, as conditions change during an outbreak, and as capabilities evolve over the long-term. (See [Reports](#) and [SMS plan](#) of [NESAASA](#), the New England Animal Agricultural Security Alliance, endorsed by the six Governors and Agriculture Commissioners.)

Specifically, the six New England states are surveying all licensed dairy farms in the region for compliance with a checklist of conventional biosecurity capabilities as well as gathering contact information and production characteristics. So far, about 70% of all licensed dairy farms in the region have been surveyed by a representative of the State Animal Health Official (SAHO) on-site with the owner or manager.³ Necessarily through this process, farmers are informed of the capabilities that regulators consider ideal and that they intend to use in prioritizing permit recommendations to Incident Command. Each capability is assigned a weighted score, indicating its relative importance for safe milk movement, by consensus judgment of the six SAHOs, two District-1 officers of USDA-APHIS Veterinary Services, and three USDA-APHIS epidemiologists. Raw and weighted scores along with other farm characteristics are maintained in a secure but sharable on-line database, which also calculates a composite “Readiness Rating” (0.00 to 1.00) for each farm. The Rating indicates a farm’s overall preparedness, in regulator’s estimation, to minimize risks of spreading FMD during milk pick-up – a handy benchmark for permitting.⁴

As demonstrated in regional exercises, Incident Command can use this database to anticipate consequences (e.g., the amount of milk and the share of processor supply and farm inventory that will be sustained), given a chosen Readiness Rating required for milk-movement permits. Commanders can select a minimum Rating (and/or raw and weighted scores for select biosecurity capabilities) to optimize results – the best combination of continuity of dairy operations and biosecurity – in light of characteristics of the outbreak, the actual capabilities of farms, and response objectives at the time. As circumstances change, these data allow Incident Command to readily raise, lower, or maintain minimum precautions accordingly. In other words, New England has prepared to help Incident Command identify, implement, and adjust requirements that are optimal – as secure and sustainable as possible – at the time.⁵

Judging from draft plans, other states and regions are more focused on assuring full compliance with a similar checklist of biosecurity ideals. In cooperation with academic and private sector partners, these states are developing training and credentialing programs and audits to “pre-certify” farms that, if they are disease-free and comply with all stipulated requirements, will be at the head of the line, more or less guaranteed to receive a permit to move milk in an emergency. Everyone else in a Control Area would go to the back of the line, with regulator support contingent on just-in-time, on-site verification that they meet the same biosecurity benchmarks as pre-certified farms. In other words, authorities promise help with dairy sustainability only if farmers document that all biosecurity boxes are checked (pass/fail). In this way the emphasis is less on helping Incident Command cope with existing capabilities than getting farms to “volunteer” to meet a fixed, comprehensive set of benchmarks that, state officials say, Incident Command will require. To stay in business, dairy farms would need the equivalent of a Readiness Rating of 1.0 or higher.

A simple cumulative frequency suggests the stakes from a New England point of view.

Dairy Farms in New England by Minimum Readiness Rating⁶

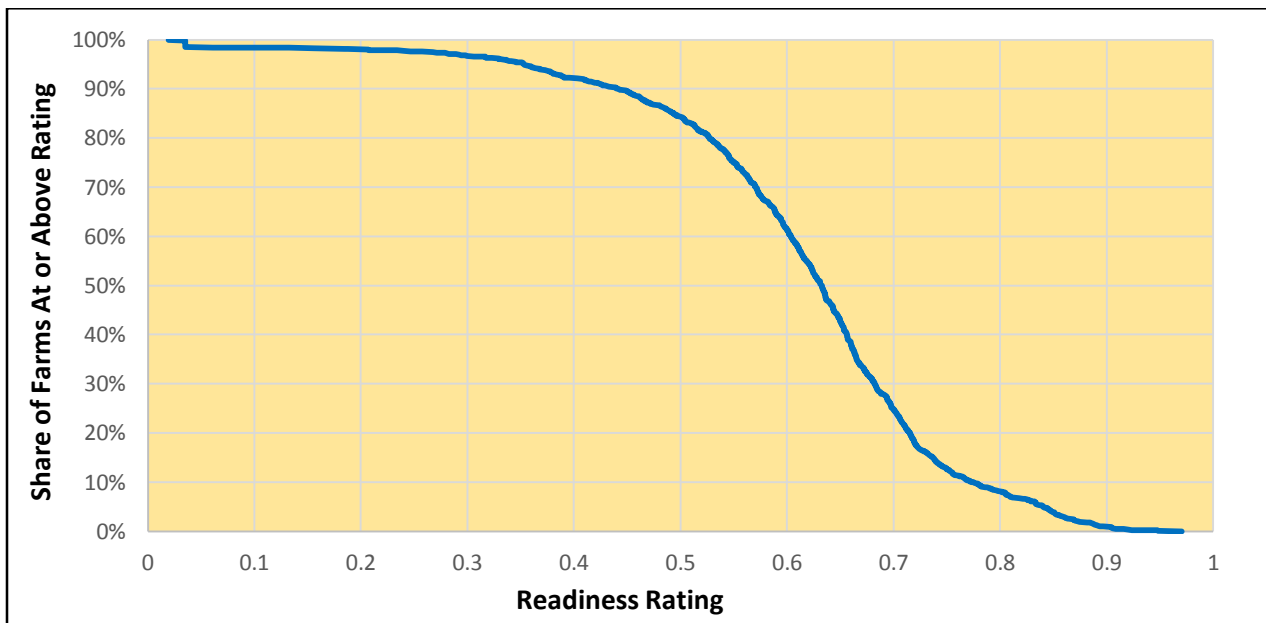

In 2013 and 2014 exercises of the New England plan, the SAHOs agreed that a minimum Readiness Rating of 1.0 would be ideal but untenable. No one could meet it. So, in simulations of a regional outbreak (the most likely scope, given the possibility of FMD transmission in normal dairy commerce), SAHOs decided that a Readiness Rating of 0.4-0.5 (sustaining about 85% of farms and production surveyed at the time) was the optimal emergency requirement.

By contrast, plans drafted in other regions require yet more stringent measures, such as training and certification of farm employees in cleaning and disinfection of vehicles, herd monitoring, and milk sampling. (New England SAHOs have assumed that these skills are close enough to ordinary husbandry and farmers’ self-interest to be just-in-time trained and spot checked, as they have been in prior outbreaks around the world.) If held to a requirement that all benchmarks are met (a Readiness Rating of 1.0 and more), not a single dairy farm in New England would qualify for a permit to ship milk. So, if plans for dairy “continuity” in other regions were nationally mandated, every dairy operation in New England would be shut down entirely, indefinitely, with little chance of recovery.⁷

The stakes for New England, in this way, are very great, indeed.

BACKGROUND: Foot-and-Mouth Disease as a Hazard

Throughout world history, experience with Food-and-Mouth Disease (FMD) has been dreadful. Infection spreads with such ferocity that each reappearance becomes the “outbreak” of the era, as if a notorious gang burst out of jail. In its venerable *Terrestrial Manual*, the World Organization for Animal Health (OIE) explains: “Foot and mouth disease (FMD) is ***the most*** contagious disease of mammals.”⁸

With rare exception, only cloven-hoofed species (such as cattle, swine, sheep, and goats, unlike humans, horses, dogs or cats) are susceptible. The disease is usually endurable but also miserable for these livestock. They are critical to agriculture, and the word “susceptible” hardly captures the depth of their vulnerability.

Immediately after inhaling even tiny amounts of a common strain of the virus (FMDV), any cow that is “naïve” (not previously exposed to that strain or vaccinated for it) will become host to a raging infection. (FMDV has seven immunologically distinct serotypes and more than sixty subtypes.) Within a few hours, it will begin exhaling a dense cloud of newborn virus of its own. Cattle that share the milking parlor, feed bunk, holding pen or pasture are nearly certain to catch it, multiply it, and pass it on. Within a day or two, likely before symptoms show, the whole herd will be shedding virus galore. A microscopic layer will settle onto exposed surfaces, where it will await stealth transfer to the boots, coveralls, and hands of herdsmen or the tires of tractors, feed and tank trucks that could carry it to other herds.

Once farmers learn that FMD threatens, they may well feel like World-War-I troops in trenches, as poison-gas sirens sound. If they could fit cattle with respirators to don on cue, they would. But by the time FMDV reaches a farm or anyone notices, preventing premises-wide exposure is a pipe dream, anyway. So instead, “in peace time” (before a domestic outbreak) governments fortify flanks. Each FMD-free nation patrols its borders, aiming to block virus at every conceivable crossing. Not one particle of FMDV is supposed to get through.

That challenge seems all the more daunting if disease begins to leap from one ground zero (the “index case”) to distant others, as it usually does. Infection can spread along subtle, convoluted courses of cross-contamination that take a horde of epidemiologists weeks to trace. With FMD as with Biblical plagues, “lessons learned” accrue mainly in hindsight and prove ever vulnerable to backsliding, error or neglect.⁹

Most of the responsibility for making sure that FMD remains (literally as well as idiomatically) a “**Foreign Animal Disease**” (FAD) has been shouldered by the Animal and Plant Health Inspection Service of the U.S. Department of Agriculture (APHIS). In collaboration with the states, the private sector, trade partners, and international organizations, their success has been remarkable. Although the disease has been endemic in most of the world for centuries, there has not been a recurrence of FMD in the U.S. since 1929. APHIS and its allies have applied lessons well in regulating the trade and traffic that every day move near or through huge reservoirs of FMDV around the globe.¹⁰

Reservoirs of Foot-and-Mouth Disease Virus¹¹

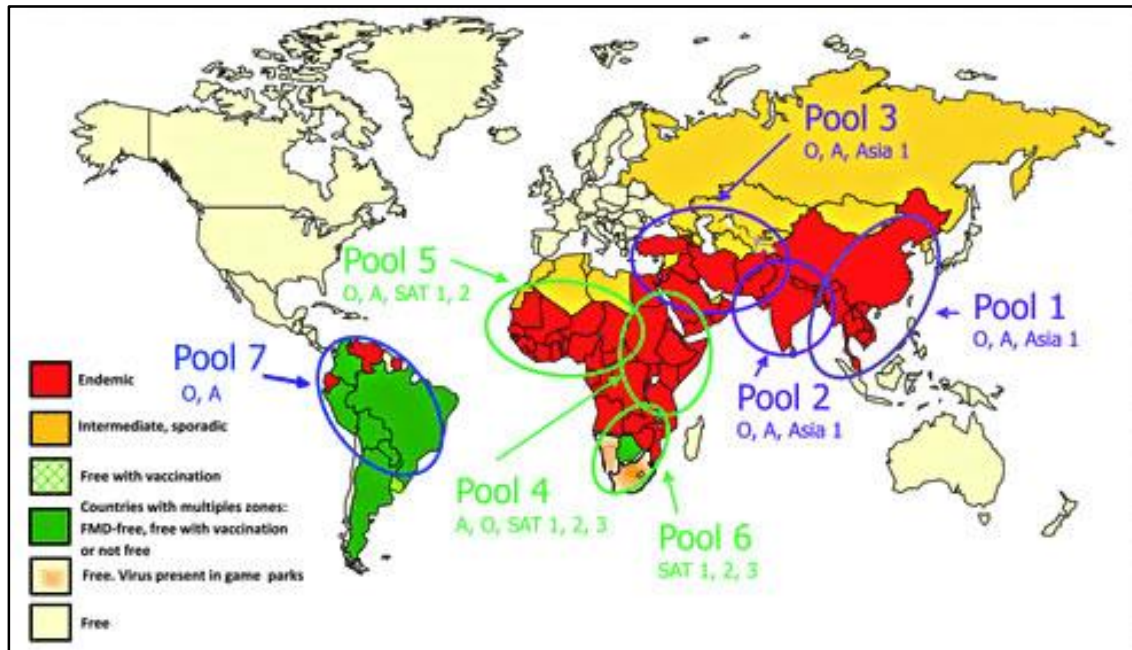

FMD-Free Nations, 2014¹²

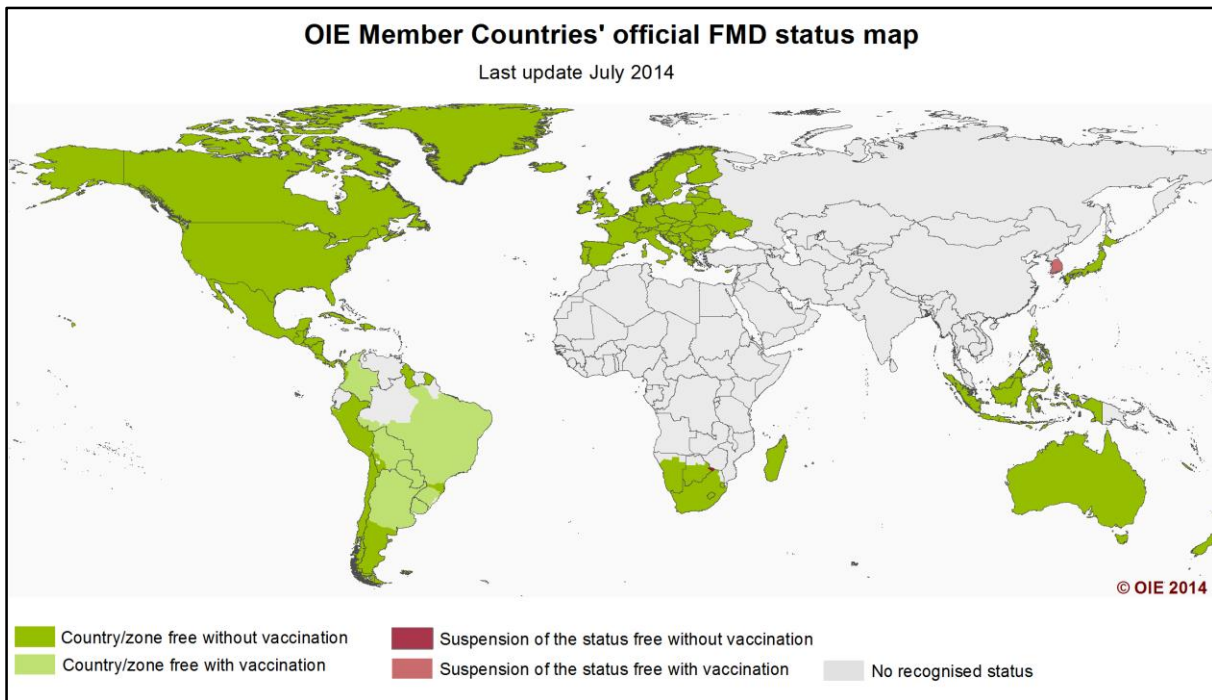

This record of success and the unusually privileged status of the U.S. – “FMD-free without vaccination” – grow ever harder to maintain as the movement of people and products and the possibility of bioterrorism increase. Recent outbreaks among formerly FMD-free trade partners suggest that an outbreak in American is probably inevitable. The realistic question has changed from “if it breaks again in the U.S. . . .” to “When it breaks, what’s to be done?”¹³

PRIORITIES IN FMD RESPONSE

If there is an infiltration of FMDV, American forces plan to retreat and regroup. They will aim to get a grip on the disease as quickly as possible.

For example, officials who police the nation's perimeter plan to muster forces around interior zones tailored to fit conditions at the time. Each zone will be designed to work like a hold in a ship or firewall to barricade ground "lost" (the area surrounding infected livestock) from everything else. These disease "Control Areas" will be administered to isolate sites of infection, monitor their perimeter, and suppress contagion.

No matter how lines are drawn – whether the bounds of Control Areas coincide with established or makeshift jurisdiction – freedom from disease is to be protected by walling it off. In Cold-War style, the strategy presumes that safety and danger can be geopolitically organized. Biological hazards can be assigned a terrain and administered like states on a map.¹⁴

So considered, if pathogens are poised to break out, boundaries should be hardened. Territory must be vigorously marked and then defended (or surrendered) to maintain maximum separation between healthy but susceptible constituents and dangerous "foreign" others. Vulnerability to contaminants is the culprit, and containment is the cure.¹⁵

Example of Defining and Adjusting a Control Area to Contain Infection¹⁶

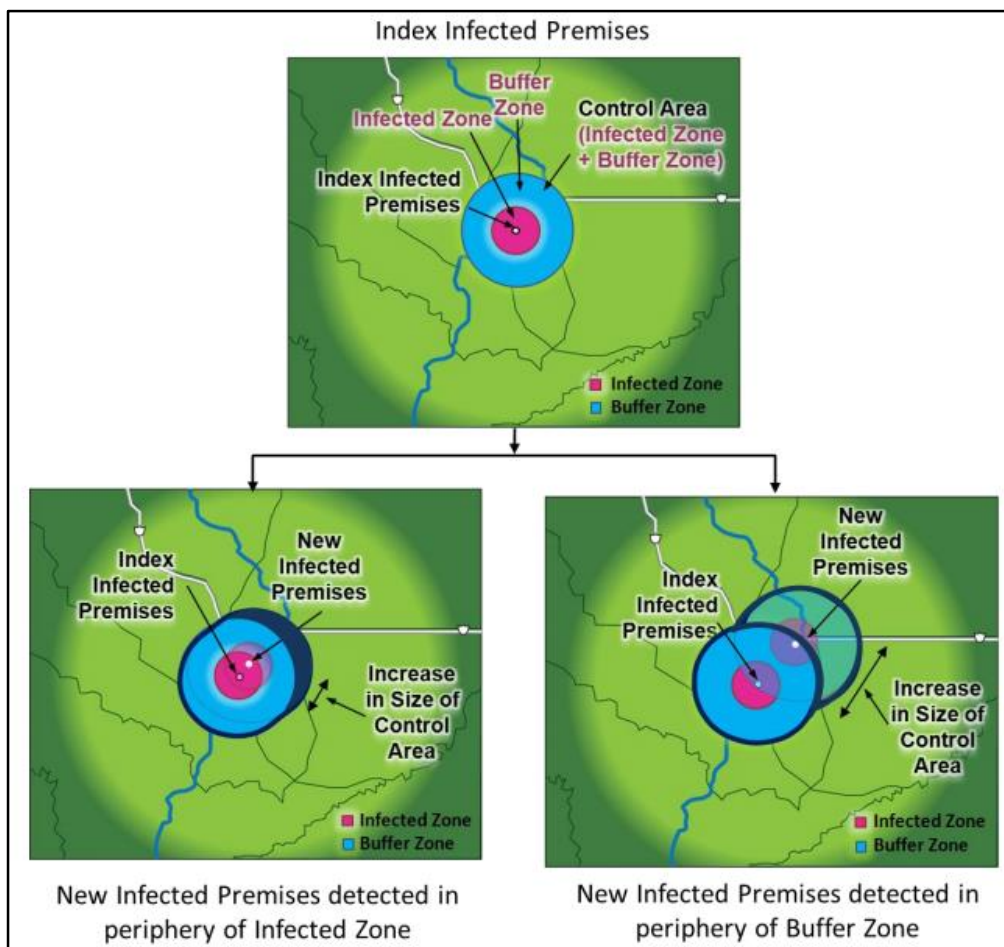

Animal-health officials recognize both value and inherent limits to such a strategy. Odds of success are best if an outbreak is detected early enough to be confined in small, manageable, contiguous zones. Even if animals and farms in a zone must be, in effect, sacrificed to halt infection, the loss would be worth it more generally for animal health, farmers and their suppliers, food processors and dealers, consumers, and the environment.¹⁷

But if Control Areas must be large – encompassing whole counties, states, or regions of the U.S., as appears likely in the case of FMD – such sacrifice may not be worth it. Effective containment may well be not only tough to accomplish but also self-defeating. Restrictions that are tight enough to seal off the most contagious livestock disease on Earth could also sever essential links in the food supply chain and sustainable routes to recovery.

Most agricultural inputs and outputs in the U.S. now travel long-distance. With important locavore exceptions (e.g., community gardens and farmers' markets), food producers, processors, and consumers are separated by hundreds of miles. They share dependence on freightage: routine supplier-to-farm, farm-to-farm, and farm-to-market shipments – regrettably also potential vectors of contagion. So, disrupting that commerce, albeit for a good cause, could bring collateral damage that would be more devastating than the disease itself. Responders have learned to recognize risk that “foreign animal disease programs also eradicate farm communities.”¹⁸

For example, if in the interest of disease control, emergency regulations obstruct tanker service to dairy farms, within 48 hours the milk that cows continue to produce would be transformed from food to waste. Huge quantities would have to be discarded daily on-site, far from facilities designed to handle such a surge. The only option may be dumping it onto land where it may putrefy and drain eventually (or readily, when ground is frozen) into waterways. Dairy processors would soon be short of supply. Shelves in grocery stores would begin to empty, inciting consumer concern or panic. As both supply and demand shrink, so would payments to farmers and thereby their ability to cover bills for feed, wages, or veterinary care at the very moment when it would be most important not only for livestock but also for farm survival.¹⁹

So, insofar as farm traffic is disrupted (e.g., suspended or delayed for just-in-time inspections or added sanitation), disease-control measures could destroy the very operations that they aim to save and much more. Restrictions used to control the 2001 outbreak of FMD in the U.K. can be considered exemplary. Well-intentioned and intensely pressured animal-public-health officials, in effect, burned villages to save them.²⁰

Instead, insofar as possible, officials are now adapting animal-disease-control plans to better accommodate continuity of commerce. Attention has shifted to tactics for managing traffic rather than simply stopping it, even in Control Areas. “Managed movement” now seems to be the most promising way – albeit inescapably with some increased risk of disease spread – to sustain the food supply chain, to minimize environmental and animal-health challenges, to sustain farms, and to increase opportunities for recovery, once the worst is over. (It is worth emphasizing: FMDV is far from the most debilitating or deadly of livestock pathogens, and its human-health consequences are negligible or nil.)²¹

There is now much agreement among U.S. animal-public-health officials that FMD-free farms in a Control Area should be allowed to continue operating (e.g., issued permits for tanker services) insofar as there are also adequate barriers to infection. Rather than shutting everything down, containment would be more precisely targeted. In particular, milk shipments may be permitted from farms with the proper precautions to prevent haulers from carrying FMDV to or from other herds.

In this way, the success of current FMD response strategies hinges on biosecurity. Tactics must be fine-tuned not only to shield farms from each other but also to maintain essential connections with the wider world. Since dairying is so dependent on daily shipments and since milk production cannot be simply turned off, these tactics would have to be deployed at lightning speed, within the first, chaotic hours following the discovery of an outbreak.²²

How, then, can emergency responders, regulators, and producers prepare to have in place the biosecurity that managed milk movement will require? How should such a fast track to safe commerce be marked? What specific strategies and tactics would be best?

SMS OBJECTIVES: Disease Control and Business Continuity

U.S. plans for responding to an outbreak of FMD unite around a single goal: minimize the impact of disease. They aim to return the U.S. to FMD-free status as quickly and efficiently as possible. Secure Milk Supply (SMS) Plans (a subset of official FMD-response plans now in development) focus on sustaining dairy operations in particular. Central to these plans is a pair of interdependent but distinct objectives: disease control and business continuity.²³

At least in principle, these two objectives are allied. Both fit the over-arching goal of FMD response, and both could be advanced with biosecurity strategies – especially monitoring, minimizing and then cleaning and disinfecting (“C&D” or “decon”) traffic at the farm gate. In prior outbreaks around the world, that is precisely where disease containment seems to have most often failed.²⁴

Experts generally agree that, once livestock shipments are suspended, the greatest remaining risk of contagion in a FMD outbreak is by way of traffic (a.k.a. “indirect contact”) to and from farms with susceptible livestock.²⁵ For dairy operations, the single most worrisome potential carrier is the exterior – especially the undercarriage, tires, and wheel wells – of milk tankers that ply farm-to-market roads every day and that must continue if licensed dairy operations are to survive or recover, if massive dumping of raw milk is to be avoided, and if stores are to be kept stocked. Experience suggests that contagion can be significantly arrested with proper control, cleaning, and disinfection during loading, transit, and unloading of unpasteurized milk.

So, once they secure their perimeters, dairy farms could remain open for essential commerce (moving supplies, milk, and money) but closed for FMDV. Containment would be focused precisely where it matters most. That is at least the conventional wisdom.

In a relatively small (“focal”) outbreak, these two objectives are most likely to harmonize. Sealing off, slowing or even shutting down a few at-risk operations could be a small price to pay for animal health, environmental protection, and business continuity at-large. In a more extensive outbreak, however, these two objectives are apt to conflict.²⁶

In light of one objective (disease control), decon at the farm gate must be exacting enough to assure that disease cannot spread. Biosecurity benchmarks should be high and firm. In light of the other objective (business continuity), decon must be easy enough to be feasible with existing resources. Benchmarks could be set higher or lower, depending on the capability of responders at the time. One objective tends to push “the bar” (minimum permissible protections) up; the other is more likely to push it down.

Hence, the two objectives pose different margins for error – the downside risk of “an excess of caution” or “precautionary principle.” If commitment to disease control were paramount, emergency managers would err on the side of halting commerce that actually threatens no one. If sustaining business were paramount, they could allow contaminated commerce to continue. In terms of the over-arching goal of FMD response, one is inclined to shut down too many dairy operations; the other, too few.

Biosecurity Objectives, Benchmarks and Risks in Permitting Milk Movement

OBJECTIVE What is the main aim of biosecurity in SMS permitting?	BENCHMARK How high should the bar be set to allow milk movement?	RISK What hazard lies on the “safe side” of error?
DISEASE CONTROL	HIGH and FIRM Up to a standard that best eliminates risk of infection	TOO DISRUPTIVE Shut down too many operations
BUSINESS CONTINUITY	FLEXIBLE Up to a standard that a critical mass of stakeholders can meet	TOO PERMISSIVE Shut down too few operations

SMS STRATEGY: The Sweet Spot

In practice, how might stakeholders – particularly officials who set emergency requirements – best prepare to accommodate the difference in these two objectives (disease control and business continuity)? What precautions should be considered “good enough” to allow milk to move to market? How high and firm or flexible should the biosecurity bar be set? Which capabilities and practices – and hence, which specific operations, what number and share of the total – should get permits to stay in business? In short, what strategies should officials consider **optimally exacting and feasible**?

In an ideal world, even in advance of an outbreak, there would be a single, obvious sweet spot: set the bar high. Dairy stakeholders should assure that strict, consistent biosecurity is also entirely feasible. For example, if most farms normally used precautions that would be effective in an emergency, there would be no need to alter them in an outbreak: Just do what you always do, albeit with more urgency and oversight.²⁷

At least in principle, there can be little doubt that stringent biosecurity – in concert with disease monitoring, animal identification, and food traceability – would go a long way to protecting animal health and the environment, the security of the food supply, and the sustainability of agriculture in general. Such measures are, in fact, becoming the norm among U.S. trade partners and competitors and consensus ideals at home.²⁸

Food Traceability, Farm-to-Fork and Cow-to-Consumer²⁹

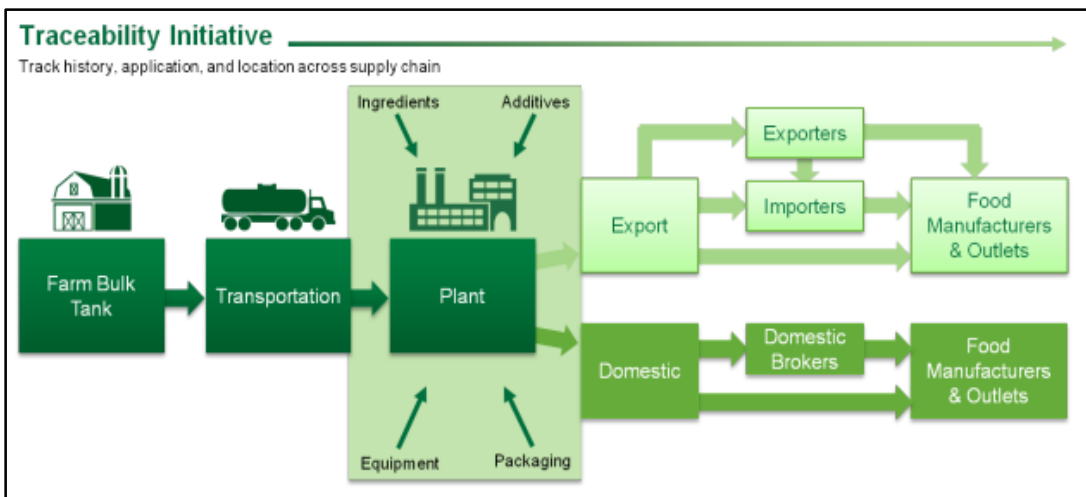
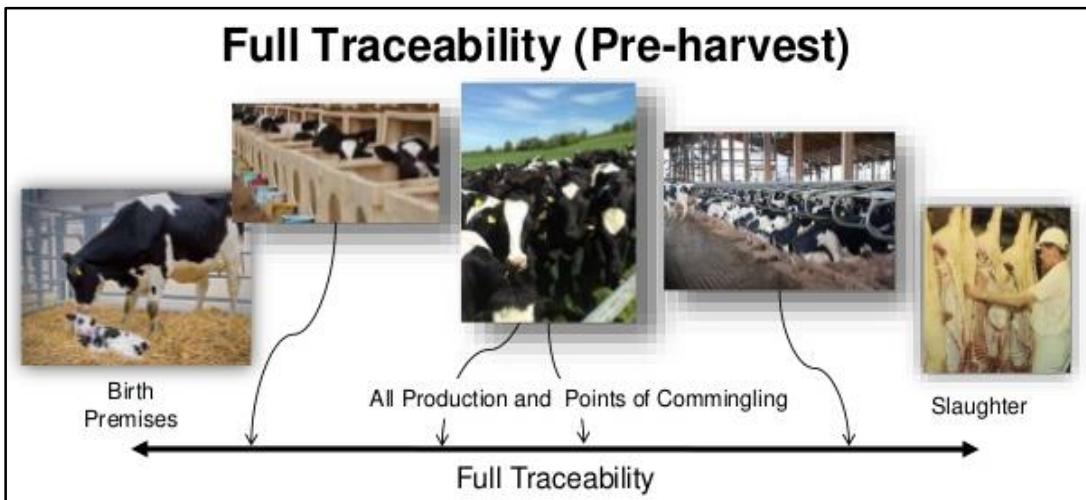
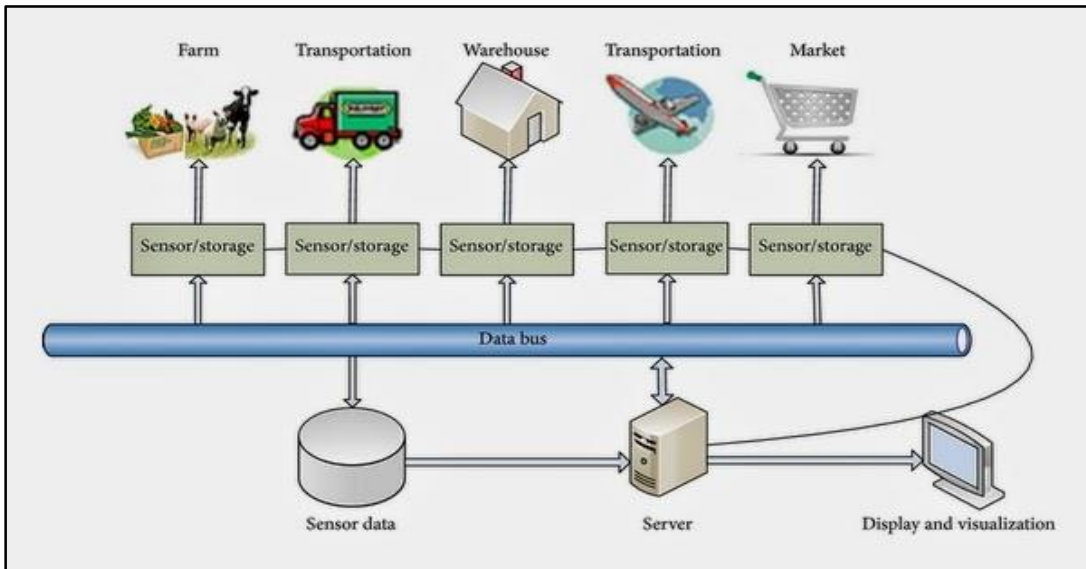

There is much to recommend in such a “horizontal” (universal, uniform) as well as “vertical” (crisis-driven, pathogen-specific) approach to safety. Policies that encourage better biosecurity and traceability could well yield safer, more sustainable agriculture as well as more effective emergency prevention and readiness to respond in the long run.³⁰

In current reality, however, these two SMS objectives substantially conflict. If an outbreak of the most likely sort (larger than “focal”) were to occur anytime in the near future, erring on “the safe side” of disease control would, in fact, endanger dairy survival and much more. For New England, it would be devastating. A main reason is that most dairy farms depend on regular hauler service and use biosecurity and traceability measures that are imperfect, at best.

Eventually, more thorough, consistent practices – including those in current SMS plans – may well be effective for disease control in a small outbreak and every day in the long run. But in the meantime and in a more likely scenario, they would be highly disruptive of agricultural operations – especially New England dairy farms – as they actually exist today.

A NEW ENGLAND DAIRY PERSPECTIVE

Agriculture in New England is singularly reliant on the survival of its dairy farms, and very few now have the resources to meet SMS requirements being advanced elsewhere in the U.S. That is why, for the foreseeable future, animal-health authorities in the region plan to use more flexible (more or less stringent) requirements for managing milk movement in an animal-disease emergency, depending on the adequacy of response resources and the situation on the ground.³¹

By contrast, in the spirit of national SMS standards released in 2012, officials in other regions are preparing to use fixed benchmarks to authorize milk-movement permits in advance (issue “pre-certifications”). They are promising business continuity (apparently, no matter what the severity of the outbreak or surrounding conditions), but only for farms that have formally trained, credentialed personnel to implement and verify compliance with a full set of prescribed biosecurity tactics. Everyone else would have to wait – presumably without tanker or feed service, disposing of milk on-site – until an official verifies that each operation meets the same high standard.³²

In a FMD outbreak of anticipated proportions occurred in the Northeast, such verification could take a huge field staff weeks or months to accomplish (plus measures to monitor and mitigate the risk that inspectors would themselves spread disease and cattle go hungry in the interim). At the moment, not a single dairy in any of the six New England states – not even a teaching farm at a land-grant institution – has such capacity. Requiring it as a condition for continuity of operation would imperil the survival of many hundreds of farms and hundreds of thousands of cattle.

When polled, New England state animal health officials could not imagine gaining enough staff and funding even to oversee such requirements. Most states can barely manage to inspect facilities once or twice a year (per licensure regulations), much less to increase the scope or pace of inspections, least of all during the first chaotic days of an outbreak.³³

Moreover, insofar as a substantial share of farms were well enough resourced to qualify for a permit and states to verify that fact, New England haulers would be hard-pressed to service them. Dispatchers normally operate at full capacity. Add the estimated time for ideal decon at each farm stop, and there would not be enough hours in the day, drivers, or trucks to cover existing routes. As it is, most trips to a processor in New England must be scheduled to include several

stops per run, often requiring close to the maximum number of hours that safety regulations allow a driver per day.³⁴

Secure Food Supply (SFS) plans, as they have evolved across agricultural sectors and regions elsewhere in the U.S., grate against such realities. Some of the disconnect (from a dairy-centered, New England point of view) may be due to the direction that these developments happened to take: from poultry and pork to dairy and from large- to small-farm states.³⁵

Compared, say, to modern poultry or pork production facilities, dairy farms – not only in New England but also in most of the rest of the U.S. – are small, independent, middle-aged or older, mom-and-pop, hands-on, open-air operations. They are often located on narrow back roads that are also routes for hauling feed and manure and that assure passing vehicles a coat of slush and road salt in the winter and dust or muck most year-round. Most farms employ just a couple of hired hands, often recent immigrants or migrants for whom English is a second language, and turnover is high. Credentialing and tracking compliance with requirements for such a work force would be expensive and difficult, to say the least, and a drain on sparse regulatory resources evermore. Qualified state staff are barely sufficient for current “peace time” responsibilities.³⁶

Nearly all dairy operations also depend on frequent, combined-load service from milk haulers that put each farm a very few degrees of separation from many others. Before, during and after each round of farm stops, haulers cross paths on their way to and from a small number of processing plants. In this way, daily tanker routes tie (and hence expose) neighboring operations to each other and to hundreds of peers.³⁷

Sample Layout of a Dairy Farm and Biosecurity Zones³⁸

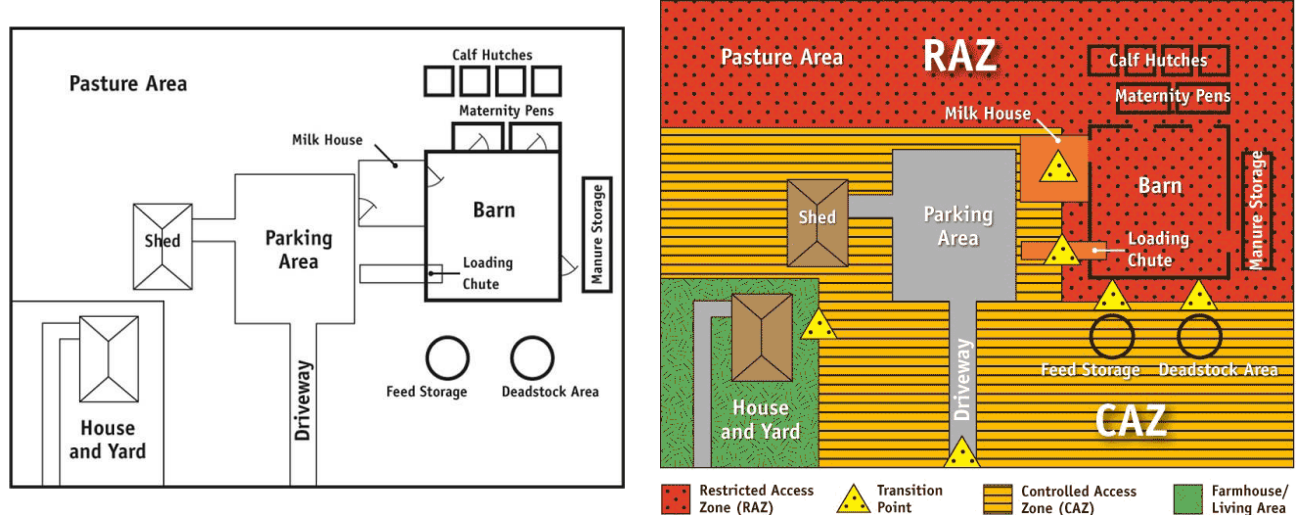

Most of the shipments from nearly 2000 dairy farms in the six New England states converge on just five plants every day, where entering and exiting tankers usually share a lane and where exterior washing would be very difficult. At most plants, it is expressly prohibited.

These are among the reasons that New England authorities expect that, by the time an outbreak is detected, the whole region would be at-risk, in effect, one giant Control Area. The six states are preparing for the possibility that they will have to manage dairy traffic together. If permitting

had to await high-bar pre-certification or just-in-time verification of biocontainment at every potential site of exposure, there would be no milk movement left in New England to “manage.”³⁹

Most U.S. poultry and swine, on the other hand, are reared within newer, well-gated, all-in-all-out (“closed herd”), negative-pressure, temperature-controlled, shower-in/shower-out facilities. They were built with biocontainment in mind. Each facility has a relatively small number of well-positioned and equipped points of transition between “hot” and “cold” zones of infection control. They are operated according to strict disease monitoring and C&D protocols, supervised by specialists who occupy a prominent place in a vertically integrated and exactingly engineered industry. Logistically and economically, they are much better able to maintain a high level of on-site biosecurity.⁴⁰

Sample Layout of Poultry and Hog Farm Biosecurity and a Plant Truck Wash⁴¹

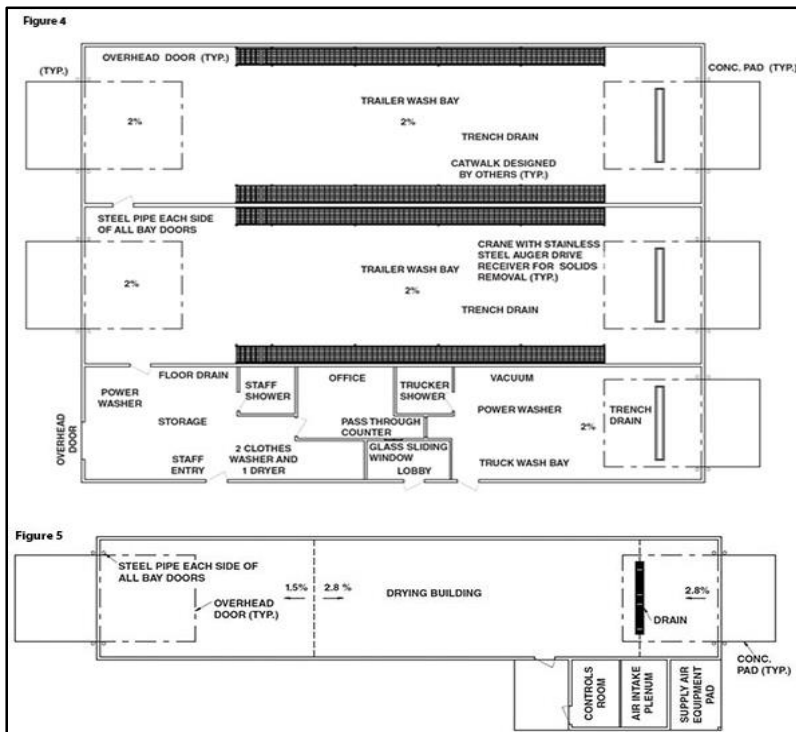
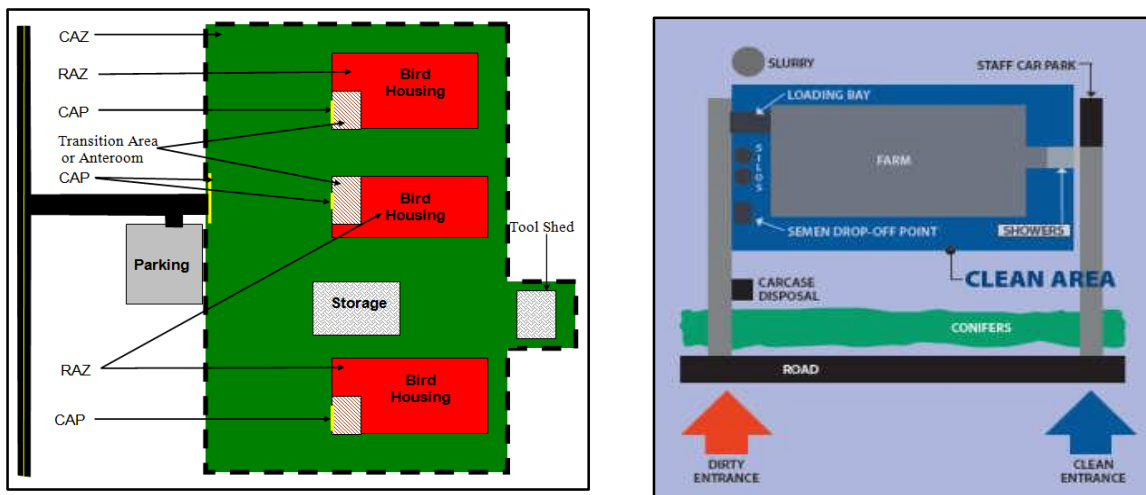

Yet even these trendsetters have found their safeguards flawed. For example, despite high biosecurity, poultry operations remain ever plagued by varieties of Avian Influenza (AI). Outbreaks that kill or require euthanizing millions of birds to control are too common among commercial growers to be considered freak events. (A particularly deadly outbreak, the largest on record in the U.S., is going on as this paper is in draft.) AI remains an unwelcome and irregular but also unsurprising part of poultry production.⁴²

States and Farms with Confirmed HPAI, 2014-2015⁴³

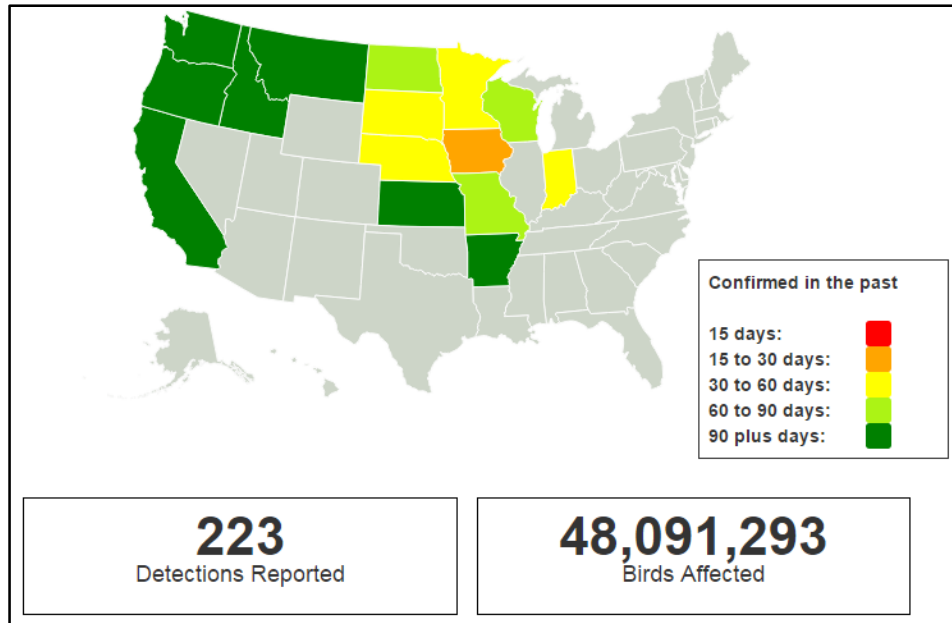

Swine, too – again, despite huge investments and achievements in biosecurity – remain vulnerable to plagues. Last year, for example, deadly epidemic diarrheal disease (PED) infected half the swine breeding herds in the U.S. and killed millions of pigs on thousands of farms nationwide (more than thirty states, including Hawaii). It was careful, intentional exposure rather than containment of contaminants that proved effective in arresting the spread of disease.⁴⁴

States and Farms with Confirmed PEDV, 2014-2015⁴⁵

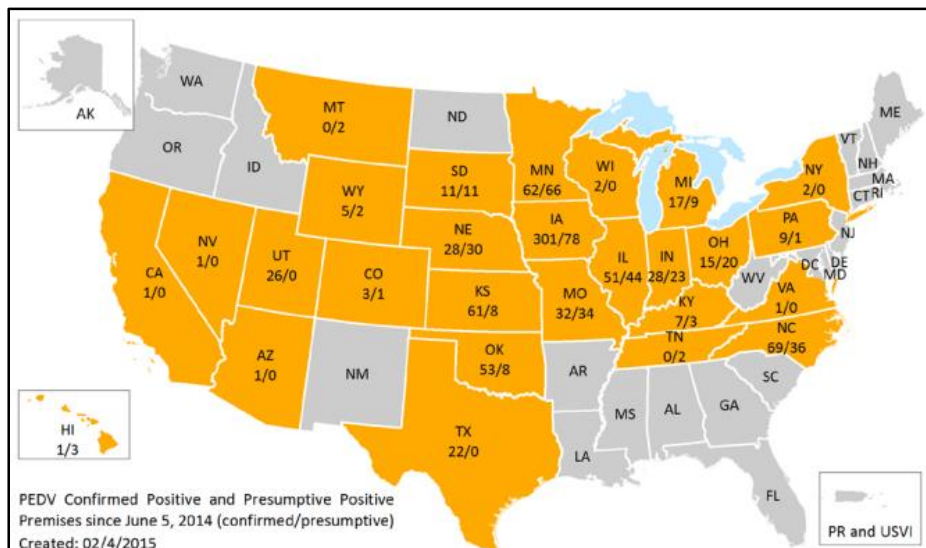

So, judging from recent real-world events, state-of-the-art biosecurity has proven disappointing, even for farms that are much better prepared than dairies and for pathogens that are less contagious than FMD.

Dairy farmers may not be faulted for being slow to embrace pork- or poultry-style improvements when they lag so far behind and when great, albeit reduced vulnerability to infection seems so certain to remain.

Payback on disease-containment capacity seems even more limited, given the degree to which the risk in FMD is driven by politics rather than animal health. National policies and international agreements (particularly rules administered by OIE with the authority of the World Trade Organization) greatly increase the fearsome costs that countries suffer if they report FMD or vaccinate against it. If reducing health risks or production losses were the goal, no doubt, other diseases would be higher priority and vaccination more encouraged.⁴⁶

Furthermore, in the event of an outbreak – no matter how well stakeholders prepare or how few livestock are affected – American exports are sure to suffer massively for many months or even years, with losses totaling billions of dollars. If the U.S. detects FMD or vaccinates against it, trade rivals are likely to erect barriers against American exports that are even higher than those specified by OIE, just as the U.S. has done to its “trade partners” in the past. So, no matter how much farmers invest in complying with SMS plans or how well they, in fact, secure their facilities, losses from a FMD outbreak are nearly certain to be staggering, and prospects for government indemnification are poor.⁴⁷

So, why should officials plan to deny farms – specifically uninfected premises in a Control Area – permission to ship their milk to market for failing to meet biosecurity standards that just about no one could now meet and that could fail to control infection or prevent massive losses, anyway?

One answer is in the adage, “Don’t let the perfect be the enemy of the good.” Even if biosecurity cannot guarantee success, it sure could help.⁴⁸

Sanitation, Feasibility, and Flexibility in Farm Biosecurity⁴⁹

Farms are not sterile environments and initiatives to reduce the zoonotic hazards have to be practical, economically feasible and flexible, depending on the scale of the enterprise, the species being farmed, and the epidemiology of the zoonotic agents in the particular geographical region. . . . [However,] enforcement of sanitation rules including the use of disinfectants at key points and the wearing of protective clothing and footwear, together with effective controls on the hygienic quality of feedstuffs and water sources . . . are standard biosecurity practices which are necessary if the integrity of the production unit is to be maintained.

– Collins and Wall (2004)

Fact is, by far the greatest risk of spreading FMD is in animal- rather than milk-movement (direct versus indirect contact), and halting such risky traffic is distinctly feasible in New England. Concentrated animal feeding operations (CAFOs) with widely separated phases of production are rare in the region, and the six states have already agreed to suspend livestock shipments immediately, if FMD breaks. That one measure may keep the whole region free of FMD and

therefore, too, free to keep milk moving. (According to current plans, outside Control areas, permits would not be required.) So, at least on this one biosecurity front, New England is actually prepared to set the bar higher than may be feasible in most of the rest of the United States.⁵⁰

Furthermore, FMDV is among the easiest of pathogens to remove. On hard surfaces, most of it can be simply washed off and rendered harmless with common, inexpensive, relatively mild disinfectant (such as household bleach or citric acid).⁵¹

In successful efforts to control prior outbreaks around the world, such measures ultimately sufficed. Outside of quarantines, farmers were advised and entrusted to do the right thing. Protection at the farm gate amounted to self-monitoring and minimizing traffic and then washing each vehicle on the way in and out. In nearly all cases to date, there were few or no specifically mandated procedures nor formal training and certification of people to follow them.⁵²

Certainly if the bar were set higher (e.g., with uniformly well-designed vehicle wash stations, more demanding and detailed, written SOPs, credentialing, and oversight), such measures might have worked better, but they did work eventually, anyway. For example, a pilot study in the U.K. in 2001 found that farms that controlled traffic and used a pressure sprayer at the farm gate were about 80% less likely to be infected than those that did not.⁵³ About 90% of licensed dairy farms in New England could already meet that benchmark. “Minimize and wash the traffic” could well be both an effective and feasible height for the biosecurity bar.

Readiness to Clean Vehicles at Dairy Farm Gates in New England⁵⁴

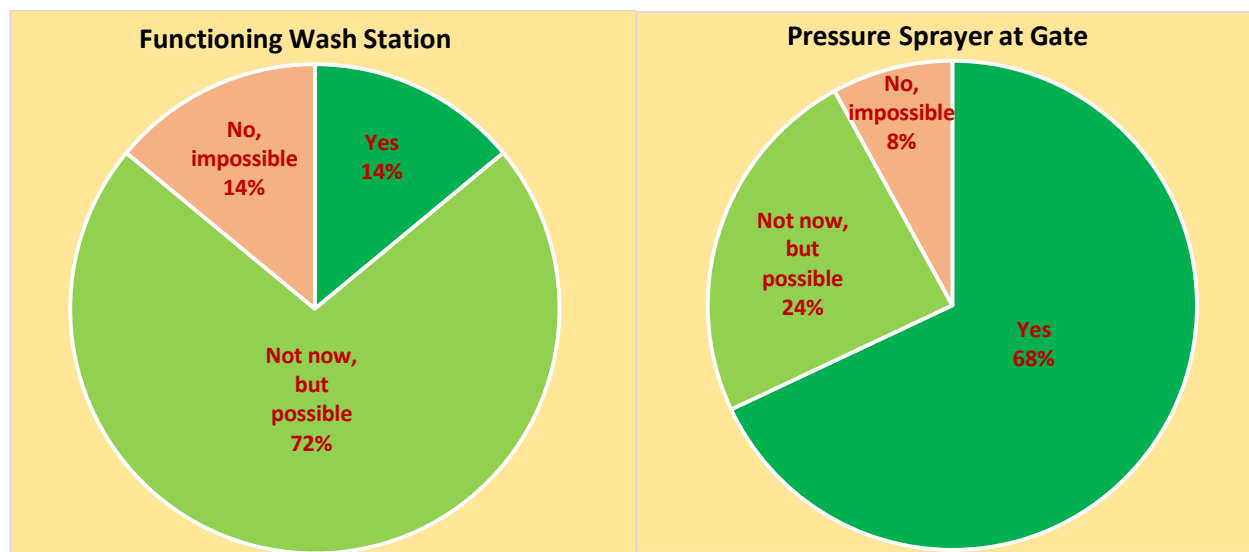

The point here is **not** that other SMS benchmarks are too high or that the bar should be set “lower” to suit New England’s current capability (which is unusually good in some respects).

There is, in fact, nationwide support for improving farm biosecurity. States share in the overall goal of FMD control as well as allied objectives, and the national SMS performance standards allow for regional variation in tactics. Checklists of minimum and best practices that have been developed around the U.S. – including New England – are nearly identical. If an outbreak in the future were well-contained and capabilities improved, there would be good reason to insist that every box be checked and verified before permitting potentially contaminated commerce to continue.

But in the meantime, it would be wise to prepare for the possibility that a different “sweet spot” – above or below what seems ideal at the moment – may be better. In a small, well-contained outbreak, the bar might best be set yet higher, to stop all traffic with even the most remote possibility of contamination. Given the likelihood of a large outbreak and resource limitations, however, biosecurity benchmarks might best be set a bit lower. Or conditions might require transitioning from one to the other.

SMS planning in New England differs from other regions mainly in its focus on preparing for just such possibilities. No one in New England is being promised that they will or will not receive a permit to continue operations, come what may. Instead, the region has developed a tool (“Readiness Rating”) to rapidly determine and set the bar at the appropriate point – the sweet spot between too permissive and too restrictive – that circumstances at the time allow. Stakeholders are being advised how to improve their own prospects of gaining a permit and thereby the sustainability of dairying in general.

Current ideals and long-term strategies for protecting animal health and agriculture can continue to foster better biosecurity and traceability. In the near term, as well, both regulators and dairy producers can benefit in recognizing how far they have to go. At the very least, even if the bar (minimum precautions for permitting milk movement) must be set high for now, emergency-response authorities would be wise to consider contingencies. A disaster is not a good time to first openly, candidly consider coping with a gap between ideal and actual capability.⁵⁵

In short, plans for response to FMD can and should be ready to respond to the specific threat at the time and the actual capacity of government authorities and dairy stakeholders to meet the benchmarks that permitting procedures require.

The rest of this document pursues yet more reasons to consider emergency biosecurity requirements in such a flexible way, with due regard for uncertain circumstances and outcomes. The aim remains developing optimal tactics for managed milk movement, the best possible way to meet **both** disease-control and business-continuity objectives.

LIMITATIONS IN “SCIENCE-BASED” EMERGENCY MANAGEMENT

Planners assess FMD risks and tactics in light of the situation, their objectives, common sense, and the best available research on the subject. Decades of experiments, simulations, and experience with outbreaks around the world have greatly advanced scientific understanding of this disease, viruses and infection control more generally. Certainly, these findings deserve a larger role in emergency management than faith or folklore alone. FMD can be better understood and controlled as the work of a particular pathogen (a virus that endangers select species and that can be deactivated) than as a matter of fate, miasma, or imbalance in the humors of sheep.⁵⁶

Plans for readiness and response also have a decent chance of winning trust (and by democratic standards, deserving it) when they acknowledge not only the lessons of science but also their limitations. Such acknowledgment is regrettably rare when science is “applied.” Officials often boast that their chosen tactics (or their advisors’) are “science-based,” but researchers well know the weakness in that claim, especially if they have government experience. Public policies are only rarely or indirectly derived from natural or medical science, as practitioners understand it.⁵⁷

Some of the slippage can be attributed to the messiness of governance, but much of it is also attributable to the limits of science itself. Ubiquitous (but often ignored) caveats explicitly discourage simple, straightforward applications in ordinary circumstances. For example, controlled experiments and disease-spread models can be used to forecast events, but only insofar as the real-world reflects the controls, parameters, and assumptions on which they rely. Likewise, analyses of prior, naturally occurring events can help with projections, but only insofar as the future resembles the recorded past.⁵⁸

In this way scientific predictions (such as the strain of FMD that will next break in the U.S., how it will behave, or how best to control it) are both valuable and limited. They can demonstrate the plausibility of strategies for mitigating risk, but they cannot show that tactics will actually work or even that that they should be tried. Findings better serve contingency than certainty.⁵⁹

At best, their role in emergency management is conditional and probabilistic: “If you do X, all else being equal, there is Y% certainty of result Z.” Of course, “all else” is never quite equal. No matter how obvious or urgent the goal or the “confidence level” that reigns in the relevant science, someone or some institution has to exercise the judgment and authority to decide whether Y (the level of certainty) is sufficient and whether X (the mitigation) is “worth it,” given risks, benefits, priorities, and resources available at the time. These questions are inescapably political.

Scientists can be helpful as “honest brokers” in such deliberations, but the power and authority to reach a decision (do or don’t do X) comes from elsewhere, from some combination of the force of leadership, the support of followers, and the forbearance of subjects. Findings do not in themselves determine their relevance or use in the wider world.

Likewise, regulators cannot honestly outsource responsibility for their decisions. “Due diligence” is more than a matter of deference to experts, especially if the people who administer or who are subject to “science-based” regulation do not know or trust the source. As students of science in policymaking stress, failure to acknowledge uncertainty and accountability can diminish not only public confidence, cooperation, and democratic principles but also science itself.⁶⁰

Such uncertainty is especially pronounced in the case of emergencies. They are by definition singular events, rare and unpredictable. They cannot be truly “replicated” in experiments or runs of models. Fortunately, simulated disasters are a far cry from the real thing.

That difference is among the reasons that researchers and emergency managers seem to be ever preparing, not for the next disaster, but for the last one. Its impact remains vivid enough to attract attention and funding. Fresh data are usually the most amenable to state-of-the-art analysis. In this way, science blows with whatever wind is at its back. But judging from past experience, fallible as it may be, the next disaster will be very different from the last.⁶¹

Also because disasters are essentially unique, organizations that monitor animal-health emergencies (e.g., OIE, FAO, DEFRA, and USDA-APHIS) do not require reporting of “production diseases” like “scours” in swine or “shipping fever” in cattle. These illnesses can also have dreadful consequences, but they are too common to be considered disasters. They continually yield rich data about their course and corrections that could help. Stakeholders can calculate the likely costs and benefits of mitigations and budget accordingly. In the language of insurers, these diseases are closer to “risks” that can be amortized than “chance” or “acts of God” that cannot. Diseases that cause disasters require limber surveillance and response regimens of their own.⁶²

The U.S. government now admits that it cannot promise to cover all of the potential losses from an outbreak of FMD. Expert estimates of the cost range from a few million to tens of billions of dollars. With such uncertainty about the stakes, calculations of the relative value of mitigation – whether, for example, investments in certain precautions are truly “worth it” – are bound to resemble anyone’s guess, no matter what the attending “science says.”⁶³

LIMITATIONS IN “SCIENCE-BASED” MANAGEMENT OF FMDV

Viruses can present particularly uncertain risk. Tiny variations in their genetic makeup can have huge consequences. Change a couple of proteins here or there, and they can be transformed from innocuous to lethal or vice versa. Since they use hosts’ genes to multiply, and since they have relatively poor control over the accuracy of their own replication, RNA viruses like FMDV can mutate and rapidly evolve, even within a single host. When they move long-distance (say, from a pool in South America or Asia to North America), the possibility of change in the genotype and its effect massively increase. Such variation, for example, can make vaccine extremely difficult to develop. By the time sights are properly set, the target is apt to have moved.⁶⁴

Limits to the scientific study of FMDV are also formidable by design. For good reason, for example, government regulations greatly restrict the kind and, hence, the number of facilities and pace of research that involves the actual virus. It can only be handled in select, highly secure (BSL-3 or BSL-4) facilities, and they aim to be yet more restrictive. A couple of the world’s most trusted sites – Plum Island in the U.S. and Pirbright in the U.K – have seen FMDV escape primary containment several times in recent decades. The security of facilities for development and production of vaccines (e.g., live attenuated FMDV) have proven infamously worrisome and face government constraints around the world.⁶⁵

Safety and animal-welfare regulations skew not only the location and pace but also the substance of FMD research. If active FMDV is to be experimentally introduced, as few animals will be exposed, with as little virus, under as controlled circumstances as possible. So, in many scientific investigations of disease transmission, mathematical simulations and surrogates – e.g., in vitro bovine rhinitis B virus (BRBV) or equine rhinitis A virus (ERAV) and select host cell cultures – stand in for actual FMDV and animals.

In other words, permissible protocols and practicalities in FMD research tend to favor studies of microbes in labs over livestock in their ordinary environs. Researchers are thereby better able to isolate variables, to treat animals humanely, and to be sure that they do not inadvertently cause an outbreak. But as a result, too, their findings apply to working farms and disease mainly by leaps of imagination and extrapolation. The unevenness in the resulting bulk of FMD research can alone make landings of those leaps tough to stick.⁶⁶

For example, contagion requires three components: a pathogen, a host, and an effective connection between the two (a “carrying agent”). No one or even two of these factors can suffice. Conditions must be aligned on all three fronts (e.g., vulnerable tissue must become exposed to enough of a proper strain of FMDV, given the temperature, humidity, size and health status of the herd, etc.) Since they are so suited to laboratory investigation, two of the factors have been more thoroughly researched than the third. Microbiology well supports understanding of the pathogen itself and the way it **can** interact with a susceptible host cell. Beyond that – on carrying agents and actual transmission of disease from one herd to another (Rh) – not so much.⁶⁷

Transmission between farms depends on the contact structure between farms. Experimental data cannot be extrapolated directly to a field situation. Therefore, field data are needed to optimize control measures as laid down in contingency plans.

– Dekker (2011)

Most small-scale FMD transmission experiments carried out until now were designed to quantify the within-herd transmission in one species. . . For most of the transmission events in 2001 [the year of the most studied outbreaks in FMD-free nations, the U.K. and the Netherlands] . . . the route was not traced and, as a result, the data do not allow useful estimations of the parameters for specific routes. Therefore, models that explicitly consider different routes, such as dairy tanker movements, animal movements, windborne spread and 'local spread', cannot use the data from the 2001 outbreaks to estimate the large number of parameters required in these models. As a result, many of these parameters are currently being guessed, or obtained by seeking expert opinion.

– Hagenaars et al. (2011)

Successful experiments to date have mainly clarified the way that miniscule amounts of FMDV can cause infection when injected into susceptible cell cultures or sites of the body (e.g., epithelial regions of the tongue in cattle – IDL inoculation – or of the coronary bands or heel bulbs of sheep or pig feet). The emphasis makes sense in research, since it is an “efficient” use of FMDV, and it minimizes the suffering of experimental subjects.

However, emergency managers who seek a lesson in these experiments should recognize, as researchers do, that natural exposure is rarely so efficient. Managing FMD outbreaks is mainly a matter of herd-to-herd rather than virion-to-cell or individual-to-individual transmission. More than one or two animals and species are involved. Injection (vs. inhalation or ingestion) is among the least likely modes of introduction of FMDV to a herd. And cells in intact respiratory or digestive tracts (i.e., in adult livestock with functioning immune systems) are less vulnerable to a single dose than common experimental surrogates (usually selected for their vulnerability) such as cells cloned from the kidney of a baby hamster (BHK-21).⁶⁹

So, in addition to recognizing proof of FMD’s hair trigger in the lab, planners should recognize the cavern between that finding and farm-variety reality. The experimental artifice – the use of isolated individuals, microbes, single serotypes and species, surrogates, efficiencies, etc. – makes research findings possible, precise, ethical, and replicable but also profoundly different than agriculture and privileges the disease-control (vs. continuity-of-operation) side of caution.

Hence, for example, researchers themselves warn that experiment-derived estimates of the “minimum infective dose” (MID) of FMDV are at best crude approximations of what should be expected in the workaday world.⁷⁰ For example, if naïve animals are continually, repeatedly challenged by a strain to which their species is distinctly susceptible, a dose that is even smaller than the consensus MID could initiate infection. That is among the reasons that a whole herd is almost certain to be infected once one of its members shows signs of FMD, no matter what other conditions prevail.⁷¹ Diseased pigs and cattle daily shed radically more virus than any MID, anyway. So, knowing the threshold for infection in experiments is not much help in managing the spread of FMD within a herd. Shortly after infection has begun, aiming to reduce ambient virus

is probably pointless. In a FMD-free herd, however, a single healthy, mature animal that is only briefly exposed may remain uninfected by a dose that is many times, even exponentially larger than the MID. So, targeting the lab-tested threshold is not necessarily helpful then, either.⁷²

Actual, natural, herd-to-herd infection depends on a lot of factors beyond the proximity of pathogen of a specific concentration. Tested, peer-reviewed, published estimates of “the” MID of FMDV diverge exponentially across strains of the virus as well as the species and immune status of the host and the means of exposure (those two other components of contagion). There is no particularly “scientific” reason for planners to proceed on a best- or worst-case assumption about any one or all of those conditions. There is little epidemiological evidence that the lowest (or highest) of estimated MIDs is also the most likely to result in infection or the best to prevent on any given farm, even from a pure, disease-control point of view.⁷³

In other words, the scientific sense of the term “Minimum Infective Dose” is very different than its common-sense interpretation or practical, clinical significance. A lesson for emergency-response planners is that the number – the expert-sanctioned, fearfully low threshold for infection – may be of little use outside a lab.

Biosecurity should not be equated with reducing virus below its “scientifically proven” threshold (i.e., purging environments of FMDV dilutions that could exceed the MID). The rule-of-thumb MID for FMDV is relevant but neither necessary nor sufficient to determine herd health, much less dairy sustainability. Alas, it all depends. Moreover, at least as important in the short term and in the most likely sorts of outbreaks, procedures to assure that FMDV is below the consensus MID on everything at the farm gate may be too difficult, costly, or simply impossible, anyway.⁷⁴

Regulators could still, “out of an abundance of caution” require measures to prevent a MID of FMDV on the premises of a farm, but in doing so, they would “err on the safe side” that is only one of three, crudely measured factors in contagion and only half the hazard in FMD. Comparable or even greater reduction in risk might be achieved by focusing more on the susceptibility of the hosts (e.g., by immunization), transmission inside the farm gate (e.g., hands, coveralls, boots and chutes that could carry virus from contaminated vehicles or lanes to livestock) and helping operations to survive and recover.⁷⁵

In short, if only because of the way the relevant research has proceeded, “science-based” FMD-emergency prevention and management are apt to direct disproportionate attention to the presence of FMDV, to the neglect of other contributors to disease spread, the feasibility of mitigations, food security, and agricultural sustainability. They encourage overstatement of the risk of disease that a nearby trace of FMDV might pose to an uninfected farm as well as the security that would be gained with fighting it at the farm gate.⁷⁶

Notwithstanding such caveats, anything that reduces the likelihood and amount of virus that reaches susceptible livestock is obviously worth recommending. A wide array of biosecurity measures (especially stopping livestock movement, minimizing and tracking traffic, clean hands, boots and coveralls) can surely help prevent the spread of disease. But there is little scientific evidence that other tactics or benchmarks – specific SOPs that have been alleged to prevent an infective dose of FMDV from passing through a farm gate – will be sufficient, workable, or worth it in the next animal-disease emergency.⁷⁷

Comparable measures for infection control have been more extensively investigated in other settings (e.g., battlefields, hazardous-material sites, BSL-3 and BSL-4 laboratories, and

especially hospitals). Although these studies also have important limitations, the landing of their leaps from science to policy and from objectives to tactics may be easier to stick.⁷⁸

LESSONS FROM INFECTION CONTROL IN HUMAN HEALTHCARE SETTINGS

When it comes to controlling biological hazards, facilities that are built more for people than livestock – including laboratories approved for handling FMDV – have much to teach. They have developed a set of barriers and procedures for biocontainment, and staff stake their lives on it. Hospitals have shown that they can protect even immunocompromised patients from pathogens that strangers shed in the Emergency Room (ER) or that an impromptu parade of visitors track through the lobby.

Attractive as it may seem, it is hard to imagine that farms could be similarly secure. Crops are grown in dirt, and livestock shed manure wherever they stand. Farmers cannot be expected to spot clean every fresh trace of body fluid. Livestock cannot be reared in diapers, gowns, masks and booties, at least outside BSL-3 or -4 facilities. High-Efficiency Particulate Air (HEPA) filters and air-lock doorways will not work on most milking parlors. No farm lane will ever be as clean as the entry to a walk-in clinic, even if it is too busy to mop more than a couple of times a day. So, farms are inherently resistant to human-sanitation ideals, but not uniquely so.

Feasibility compels compromise in all sorts of settings. For example, infection-control expert Bill Rutala (who co-authored the CDC guidelines for American healthcare facilities and who has taken some heat for championing disinfectants) notes that hospitals, including his own, do not ordinarily decon or change privacy curtains as patients move through the ER. Despite the obvious potential for cross contamination, he explains, the labor and expense of more frequent changes would be prohibitive, and studies so far yield striking little evidence that patients would be better off, anyway.⁷⁹

Such calculation of costs and benefits for infection control, cold-hearted as it may seem, are accepted in management of human as well livestock care. For example, there are more vaccines available for children (and livestock) than caretakers can or should administer. They use the ones that deliver enough protection to justify the costs and risks. So, there are strong precedents both in human and animal healthcare for preparing to work with infection-control measures that bend to practicalities.

Of course, the more that is done to clean and disinfect, the better, at least from the near-term perspective of a susceptible individual. But at some point, managers must designate precautions that, even if short of ideal, can suffice – measures that are achievable, rigorous enough to sustain essential operations, and arguably better for life in the long run.⁸⁰ Farmers no less than physicians and patients deserve fair warning about how that point will be found.⁸¹

The short answer is “when biosecurity is adequate.” But what does “adequate” mean, especially in the fog of emergency response? Which specific precautions should be required, and what will Incident Command count as evidence that they are well enough in place to permit operations to continue?

In part because the relevant science is so limited, the answer for disease-emergency preparedness purposes must also be short of certain. Alas, again, it depends. Before an outbreak and a good fix on the strain of pathogen, the susceptibility of hosts, their concentration on the

ground, the weather, etc., no one can be sure what, if any, on-site sanitation will suffice. Even less could anyone be sure which specific farm-gate practices will succeed or fail to provide protection, not just from measurable contamination, but from actual disease.

In this light, hospital experience with infection control is instructive. Of course, there are huge differences between farms and hospitals to bear in mind, but when it comes to cleanliness, most of the bias is in a single, enlightening direction. Biosecurity for human healthcare environments is both better understood and more stringent.⁸²

There is great pressure on hospitals to disinfect. Patients are much more likely than livestock to be on-site precisely because they are at-risk of getting or spreading infection, and there are lawyers saddled nearby to litigate if precautions fail. Research on how best to provide such protection is now a large, international venture, with its own journals, credentials, and specialists. Guidelines have been developed by well-funded and expertly staffed professional organizations (e.g., AHA, APIC, CDC HICPAC, IDSA, ODPHP, SHEA, SHM), and their implementation is policed by The Joint Commission. Every hospital and clinic must maintain its own standard procedures, including training and oversight of housekeeping staff who fight environmental sources of infection full-time every day. Such resources are beyond the wildest dreams of anyone who manages a farm.⁸³

Despite the capacity and the pressure, hospitals still struggle with diseases that they harbor. Healthcare Associated Infections (HAI) remain a major national problem. On any given day, 4-5% of hospital patients have a HAI. In 2011, there were more than 700,000 cases in the U.S., and about 75,000 patients died with a HAI during their hospitalization. Most HAIs were acquired in ordinary settings (outside operating rooms or intensive care units) from pathogens that are much tougher to deactivate than FMDV.⁸⁴ A few of them have become resistant to standard antimicrobial agents and treatments. (Many specialists now believe that overuse of antimicrobials may be significantly to blame. Routine disinfection presents sustainability problems of its own.⁸⁵) Now that Medicare and Medicaid have reduced reimbursements for readmissions to treat HAI, financial as well as legal, ethical, and medical incentives have made infection control all the more important. Risks resources, and regulations all encourage hospitals even more than farms to favor biocontainment, as they balance disease-control and business-continuity objectives.⁸⁶

So, hospital experience with HAI affords relatively well-vetted, err-on-the-stringent-side lessons for setting the biosecurity bar, for deciding **how** to be **flexible and effective**. Whatever practices have proven promising for disease control in hospitals would be worth considering on farms, too. Likewise, controls that hospitals have found ineffective or short of worth the cost are almost certainly too much for farms, as well.

Three principles that are widely presumed in current approaches to human infection control may also deserve a more prominent place in planning for agricultural emergencies like FMD:

- **Develop confidence-graded tactics.**
- **Favor tactics with proven health benefits.**
- **Adjust tactics as returns diminish.**

DEVELOP CONFIDENCE-GRADED TACTICS

American animal-disease emergency-response plans routinely claim a foundation in research on the likelihood of risks and the effectiveness of remedies. Discussions of variation in the quality or

relevance of that research, insofar as they exist, are relegated to separate supporting documents.⁸⁷ Human healthcare guides, however, more explicitly address that variation and condition tactics accordingly.

For example, experts in “evidence-based medicine” – such as the Centers for Disease Control and Prevention (CDC), the Department of Health and Human Services (DHHS) Agency for HealthCare Research and Quality (AHRQ), the Society for Healthcare Epidemiology of America (SHEA), the Infectious Diseases Society of America (IDSA), and the U.S. Preventive Service Task Force (USPTS) – couch their recommendations, not only in benefits forecast in scientific research, but also in variations in realizable benefits and in the relevance and reliability of the research itself.⁸⁸

In aiming to improve healthcare, they ask: “What sort of recommendations would be most important for particular groups (e.g., varieties of patients, visitors, or staff)? Should we recommend that they do A or B (e.g., use disinfectant or just detergent in wash water)?” They look for answers in the scientific literature: “What desirable and undesirable outcomes of A and B does research lead us to expect? With what level of confidence?” Practitioners increasingly insist that recommendations should reflect not only their estimated importance, costs and benefits but also their confidence in the significance and quality of the research that produced those estimates in the first place. In general, the more urgent the need and the more relevant and reliable the research, the stronger the recommendation.

Grading Evidence of Effectiveness and Recommendations for Healthcare⁸⁹

Grade	Definition
I. High	Highly confident that the true effect lies close to that of the estimated size and direction of the effect. Evidence is rated as high quality when there is a wide range of studies with no major limitations, there is little variation between studies, and the summary estimate has a narrow confidence interval.
II. Moderate	The true effect is likely to be close to the estimated size and direction of the effect, but there is a possibility that it is substantially different. Evidence is rated as moderate quality when there are only a few studies and some have limitations but not major flaws, there is some variation between studies, or the confidence interval of the summary estimate is wide.
III. Low	The true effect may be substantially different from the estimated size and direction of the effect. Evidence is rated as low quality when supporting studies have major flaws, there is important variation between studies, the confidence interval of the summary estimate is very wide, or there are no rigorous studies, only expert consensus.

Grade	Definition	Suggestions for Practice
A	The USPSTF recommends the service. There is high certainty that the net benefit is substantial.	Offer or provide this service.
B	The USPSTF recommends the service. There is high certainty that the net benefit is moderate or there is moderate certainty that the net benefit is moderate to substantial.	Offer or provide this service.
C	The USPSTF recommends selectively offering or providing this service to individual patients based on professional judgment and patient preferences. There is at least moderate certainty that the net benefit is small.	Offer or provide this service for selected patients depending on individual circumstances.
D	The USPSTF recommends against the service. There is moderate or high certainty that the service has no net benefit or that the harms outweigh the benefits.	Discourage the use of this service.
I Statement	The USPSTF concludes that the current evidence is insufficient to assess the balance of benefits and harms of the service. Evidence is lacking, of poor quality, or conflicting, and the balance of benefits and harms cannot be determined.	Read the clinical considerations section of USPSTF Recommendation Statement. If the service is offered, patients should understand the uncertainty about the balance of benefits and harms.

Category, grade	Definition
Strength of recommendation	
A	Good evidence to support a recommendation for use
B	Moderate evidence to support a recommendation for use
C	Poor evidence to support a recommendation
D	Moderate evidence to support a recommendation against use
E	Good evidence to support a recommendation against use
Quality of evidence	
I	Evidence from ≥ 1 properly randomized, controlled trial
II	Evidence from ≥ 1 well-designed clinical trial, without randomization; from cohort or case-controlled analytic studies (preferably from >1 center); from multiple time series; or from dramatic results from uncontrolled experiments
III	Evidence from opinions of respected authorities, based on clinical experience, descriptive studies, or reports of expert committees

Nearly all major U.S. and world human healthcare organizations use a variant of this approach: “Grading of Recommendations, Assessment, Development and Evaluation” (GRADE).⁹⁰

GRADE directs attention to a host of considerations. It begins with an assessment of the significance of the issue under review for particular populations and for public health. If the stakes are high enough, deliberation turns to the evidence of clinical benefits, emphasizing the quality of associated research, such as sampling and measurement procedures and consensus among peer-reviewed publications. But there is also much more to consider in a cycle that is supposed to never end. The approach not only recognizes but also requires ongoing consideration of the “values and preferences” of diverse stakeholders and the adequacy of resources. Scientific findings matter, but inescapably fluid, practical, economic and political considerations prevail. They receive systematic attention, too.⁹¹

GRADE Process⁹²

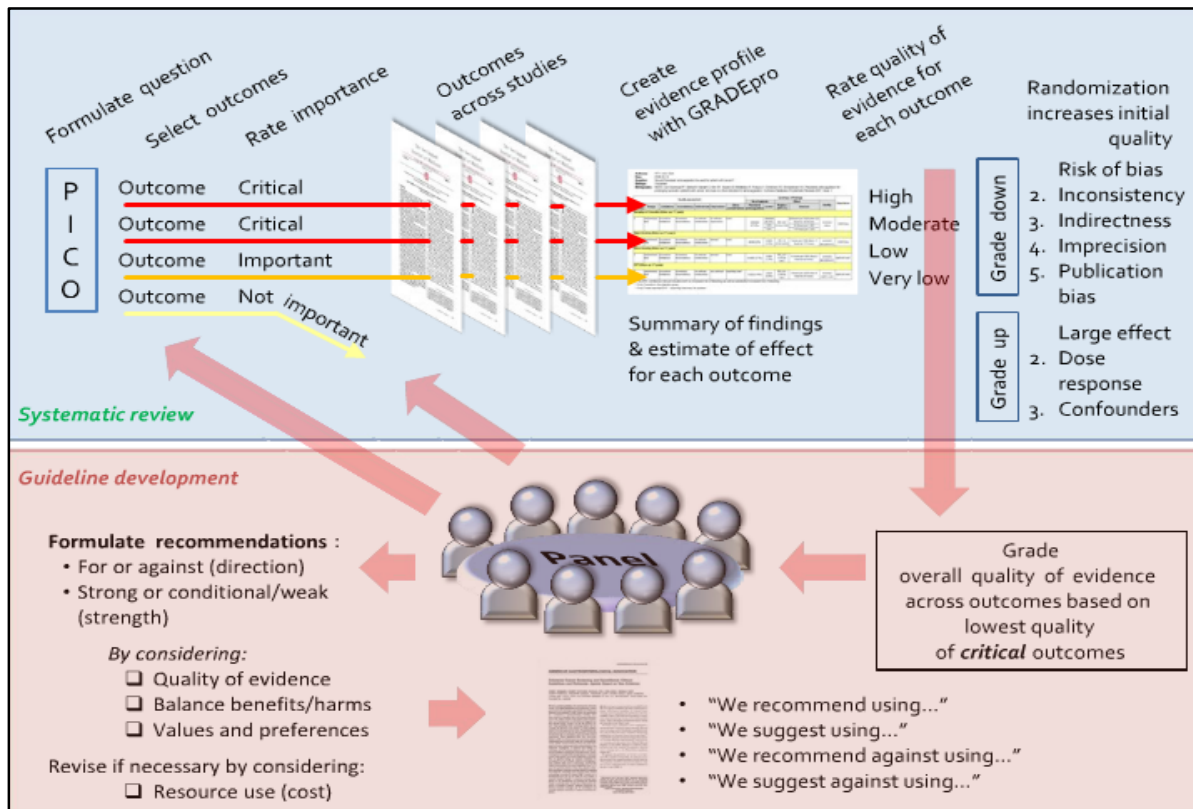

Results are explicitly conditioned on the relevance and quality of the attending science, the cost and benefits that can be expected, and the trust that stakeholders have in specific tactics. In this way, for example, the CDC routinely ranks its recommendations from strong to weak, “Category IA” to “Category II.”

CDC Categories in Recommending Infection-Control Practices⁹³

Category IA	A strong recommendation supported by high to moderate quality evidence suggesting net clinical benefits or harms.
Category IB	A strong recommendation supported by low quality evidence suggesting net clinical benefits or harms, or an accepted practice (e.g., aseptic technique) supported by low to very low quality evidence.
Category IC	A strong recommendation required by state or federal regulation.
Category II	A weak recommendation supported by any quality evidence suggesting a trade off between clinical benefits and harms.
No Recommendation	An unresolved issue for which there is low to very low quality evidence with uncertain trade offs between benefits and harms.

FAVOR TACTICS WITH PROVEN HEALTH BENEFITS

Advocates of GRADE stress that tactics should be prioritized in proportion to confidence that they will yield clinical benefits – good, actual health outcomes – rather than shifts in sentinel data. “Expert consensus” or “evidence” extrapolated from models or surrogates may suggest that a tactic should work, but it may not in fact. In-context, clinical outcomes should be determinant.



Important Questions	Outcomes
<p>Should be from practice NOT evidence driven</p>	<p>Should be importance driven NOT evidence driven</p>

Experience combating HAI reinforces these warnings. For example, hospitals have learned that the frequency and severity of HAI can be reduced but that canonical or logical, supposedly “no-brainer” or “evidence-driven” measures can also be surprisingly ineffective.⁹⁵

In a 2014 report for AHRQ, Stephen Hines explains how that could happen, how apparently sensible remedies have proven profoundly disappointing:

- **Changes that yield nominal improvements for anyone.** *Many changes are implemented between the bedside and back office functionalities that appear to offer benefits that are never achieved. In some cases, this is because the change fixes something that turns out not to be the true cause of the underlying problem; in other cases, it may be that the solution proved impossible to actually implement or because the change simply did not yield the expected benefit. Frequently, initially promising data may be the result of random variation or other factors that do not persist over time, but efforts to spread [the changes] sometimes begin before the limitations in the initial results are understood. . . .*
- **Changes that produce benefits for some organizations, patients, or units but prove not beneficial for most others.** *In some cases, changes benefit a specific organization because that organization has a unique problem. In other cases, a solution that is viable in one hospital or unit cannot be replicated elsewhere because the success factors are distinctive and unavailable in most other situations. . . .*
- **Duplicative changes that have no added benefits.** *In some cases, multiple changes can produce comparable improvements for a targeted problem. But when some of the changes are already in place, adding others may yield no additional improvement. . . .*
- **Improvements in some outcomes with accompanying harms in others.** *New drugs and medical technologies provide many examples of this, ranging from thalidomide to silicone breast implants. Although short-term benefits were clearly observable, these were ultimately outweighed by longer term harms. In other cases, benefits may prove to be nominal, while financial costs to the health care system are dramatic.⁹⁶*

In the case of infection control, measures developed to eliminate pathogens broadly, in and around a patient's environment, have turned out to be remarkably limited in their ability to reduce actual disease. (The implications for decon at the farm gate are sobering. Judging from experience with HAI, the fallibility of state-of-the-art, environmental barriers to AI and PED should be no surprise.)

Infection-control specialists have long used a matrix of risks and remedies to set priorities. They began in the 1950s, classifying contents of healthcare facilities by the plausibility that they would spread disease. Since the early 1970s, medical devices and surgical instruments have been sorted into three categories, ranging from most to least hazardous: "critical," "semi-critical" and "non-critical." This "Spaulding Classification System" remains a foundation of research and policy in environmental health to this day. Similarly, disinfectants have been classified by their strength, ranging in ability to deactivate most to least resistant microorganisms: "high-," "intermediate-" and "low-level." (Note that FMDV is among the least resistant of pathogens. Low-level disinfectants suffice.)⁹⁷

Spaulding Classification System⁹⁸

Device classification	Device (examples)	Spaulding process classification	EPA product classification
Critical (enters sterile tissue or vascular system)	Implants, scalpels, needles, other surgical instruments , etc.	Sterilization - sporicidal chemical prolonged contact	Sterilant/disinfectant
Semicritical (touches mucous membranes [except dental])	Flexible endoscopes, laryngoscopes, endotracheal tubes, and other similar instruments	High-level disinfection -Sporicidal chemical; short contact	Sterilant/disinfectant
Noncritical (touches intact skin)	Thermometers, hydrotherapy tanks	Intermediate-level disinfection	Hospital disinfectant with label claim for tuberculocidal activity
	Stethoscopes, tabletops, bedpans, etc.	Low-level disinfection	Hospital disinfectant without label claim for tuberculocidal activity

Processing Required for Microorganisms as Their Resistance Decreases⁹⁹

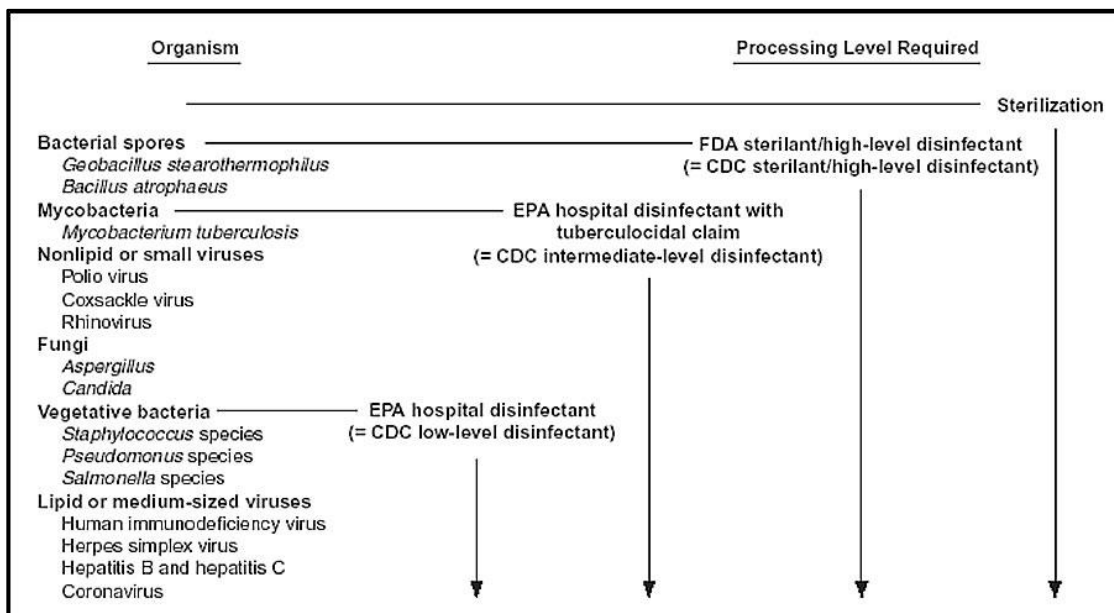

Greatest risks and therefore potential rewards for remediation were initially assumed (and soon proven) to be found in targeting resistant microorganisms on “critical” items (objects that penetrate tissue or the vascular system, such as syringes, scalpels, retractors, or catheters). Such items can be extremely efficient carrying agents. They should be not only disinfected but also sterilized. Less intense measures may suffice to prevent the spread of disease via “semi-critical items” (objects that contact mucous membranes or non-intact skin, such as anesthesia equipment or endoscopes) and yet less via “non-critical” items (equipment that touches intact skin but not mucous membranes, such as bedpans, blood pressure cuffs, crutches, or computers).¹⁰⁰

In 1991, the CDC added “environmental surfaces” (e.g., floors, walls, furnishings) to Spaulding’s list. They are presumably the least hazardous elements of healthcare settings. When contaminated, the danger to patients is mainly “indirect,” through “cross-contamination,” as when someone – a patient (PT) or health care worker (HCW) – is careless (e.g., has dirty hands, contacts splashed wash water, or uses an instrument that was dropped). Without an intermediary, wall or floor sanitation would hardly matter.¹⁰¹

Clean environmental surfaces should be redundant, back-up protection, reducing the risk that disease can be spread when more “direct” precautions fail. The same could be said of biosecurity at the perimeter of an animal-disease Control Area or, for that matter, a farm.

Redundancy and Fallibility in Biosecurity¹⁰²

The present author also advocates that any biosecurity system should have in place at least two processes on any potential fomite route that are capable of preventing spread if properly implemented. Two biosecurity processes that are each 50% effective will produce an overall effect of over 70%. This approach acknowledges that failures will occur in any biosecurity process. If two such processes are in place, a failure in one will, in most cases, be compensated for by the second being effective.

– Honhold (2006)

Critical and semi-critical items are relatively easy to identify and manage, but environmental surfaces are extremely diverse and ubiquitous by definition. So, beginning in the 1990s, as the challenge of HAI proved stubborn, experts began to chart that terrain more precisely, too. For example, they categorized surfaces by the frequency with which they were touched, hypothesizing that the greater the frequency, the more likely cross-contamination would occur and disease would spread along with it. Decontamination efforts, they figured, should be allocated accordingly.¹⁰³

They also began to discover and stress the costs and risks that the use of disinfectants can entail: e.g., slips and falls on wet floors, downstream contamination and acceleration of the evolution of antimicrobial resistance, skin irritation, allergic or asthmatic reactions, labor, training, oversight, and their expense. Pre-cleaning, minimum contact times, special handling and paperwork are also required for compliance with EPA, FDA, and OSHA regulations.¹⁰⁴

So, managers have aimed to incur those costs and risks only where they could be expected to matter most – more for “frequent-“ or “high-touch” surfaces, like door knobs or bed rails, than for “low-touch” surfaces, like windows and floors. (This approach to triaging infection control is strikingly similar to the one used in assessing risks and in developing farm “biosecurity performance standards” for the various Secure Food Supply projects.)

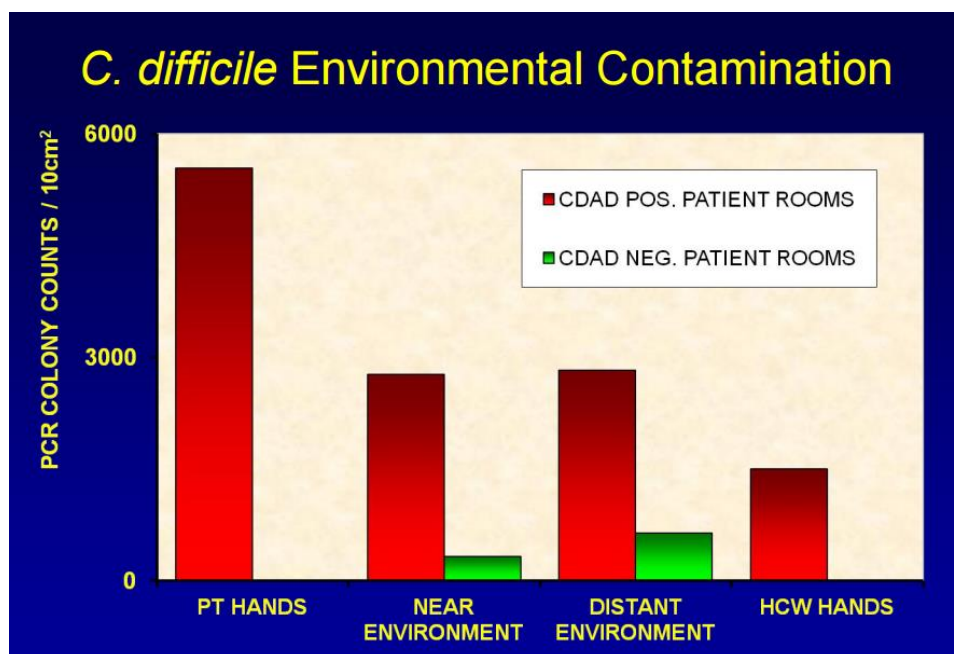

Contaminated Surfaces

	VRE	MRSA	C. difficile
Bed Rails	+++++++	+	+++
Bed Table	+++++++	+	
Door Knobs	++	++	+
Doors	+++	+	
Call Button	+++	+	++
Chair	++	+	++
Tray Table	+++	++	
Toilet Surface	+		++++
Sink Surface	+	+	+++
Bedpan Cleaner			+

The approach certainly seems sensible. Several high-profile trials that target environmental contamination have produced encouraging results in healthcare facilities. A variety of approaches to surface disinfection have been shown to reduce pathogen counts, protect patients, save money, and draw venerable endorsements. But outside those studies and the limelight, benefits have also proven fleeting or disappointing, at least in general so far. More vigorous decontamination of environmental surfaces – including special attention to high-touch surfaces – has not significantly reduced related cases of HAI (as opposed to injection- or surgical-site HAI) at the national level and, at least in some instances, may have actually increased it. Exactly why is unclear.¹⁰⁶

Although stellar examples and expressions of faith in environmental disinfection are canonical, peer-reviewed research on its effectiveness is relatively low in quantity and quality. Hence, for example, confidence grades for current CDC recommendations for treating surfaces near patients – bed rails, food trays, floors, door knobs, toilet seats, etc. – range only from Category 1B to II. In other words, the CDC warns that its own recommendations have little scientific support. Experts have good reason to disagree about the level of C&D that is, on balance, truly worth promoting, much less mandating, in the real world.¹⁰⁷

Like their agricultural associates, infection-control specialists and housekeeping supervisors press for better cleaning and disinfection. They regret that current tactics so often fail and that alternatives so rarely prove affordable and clinically effective in practice. Even C&D promoters – including manufacturers and researchers with their own patented remedies – note that research to support their position is lacking.¹⁰⁸ The gaps that they have identified are striking. They include proof for foundational assumptions, as in selecting ways to disinfect or even to know that disinfection (vs. simple wash and rinse) is appropriate.

Gaps in Research to Support HAI Control¹⁰⁹

TOPIC	PURPOSE
Cost-effectiveness	Rigorous and unbiased analyses of the cost-effectiveness of cleaning and disinfection technologies
Standardization	Support for standardized use of a single EPA-approved agent for cleaning and disinfection and for regulatory guidance in manufacturer testing of cleaning agents for safety and compatibility with common surfaces
Contact time	Support for regulatory guidance in testing of microbicidal activity using practical situations and common surfaces
Threshold of environmental contamination for acquisition of significant pathogens	An acceptable threshold to be used as the standard for evaluating the ease by which various disinfectants and application methods achieve this threshold
Association of the threshold of environmental contamination and the infectious dose for key pathogens	Pragmatic recommendations that account for the likelihood that an infectious dose would be delivered from a contaminated environment through routine contact

A few much-cited studies that fit the bill have found that disinfected surfaces are almost immediately recontaminated, no matter how they were treated. In busy wards, for example, just an hour or two after mopping with disinfectant, the bacteria count on floors is about the same as it was before. Moreover, areas that are rarely touched like windows have nearly the same concentration of contaminants as privacy curtains, before as well as shortly after cleaning. In ordinary clinical settings, cross-contamination from wash cloths, mops and buckets has been shown to be as effective in spreading pathogen as in containing it.¹¹⁰

In one particularly infamous case, a fresh start in an entirely new facility made no difference:

In 1979 the University of Wisconsin Hospital moved from its 56-year-old building into a new, considerably more spacious facility, providing a unique opportunity – literally an experiment of nature – to examine prospectively the relation between environmental contamination and endemic nosocomial infection. We cultured air, surfaces, and fomites throughout the old hospital and throughout the new hospital immediately before taking occupancy and again after 6 to 12 months of occupancy. Despite major differences in environmental contamination between the old and new hospitals, the incidence of nosocomial infection in patients remained unchanged. We conclude that organisms in the inanimate hospital environment contribute negligibly to endemic nosocomial infection and that routine microbiologic surveillance of the inanimate environment is not cost effective.¹¹¹

Since rewards for monitoring and disinfection of environmental surfaces have proven so elusive, infection-control specialists in hospitals and clinics are promoting alternatives, ranging from revitalization of good-ol' housekeeping to cutting-edge robotics and materials science. The most promising so far still seems to be staunch, simple "Standard Precautions."¹¹² For example, if hands are properly sanitized and gloved before they touch a patient, it should not much matter what those hands touched before. Research on clinical outcomes generally confirms that conclusion. In the near-term (at least until the costs and benefit of new technologies are more proven) the lesson for HAI control is to focus on preventing transmission of disease more than eliminating environmental microbes. Wholesale microbicide may be worse than a waste of effort, although the limits of that lesson – the points at which it becomes a waste – remain highly contested.¹¹³

Analogous findings in agriculture are few, but they do exist. For decades, for example, FMD-response planners strained to work with the prospect of losing a huge share of their human resources at the beginning of an outbreak. The reason was conventional wisdom requiring that responders be, in effect, isolated for 72 hours, once they step onto a farm (e.g., to investigate suspicious symptoms) that turns out to have livestock with FMD. The concern was that, even with Standard Precautions, they might carry inhaled FMDV to the next farm they visit. If that precaution were followed, after the first day or two of an outbreak, few vets or techs would remain available to treat casualties or to monitor other premises.¹¹⁴

That 72-hour rule evolved from a burst of aerobiological research prompted by the surprising course of a FMD outbreak in the U.K., 1967-1968. FMDV apparently blew tens of kilometers with the wind. (There is now consensus that such long-distance, airborne contagion must be rare. It requires a coincidence of many unlikely conditions.) That one instance may have been a fluke, but "aerosolization" has been on the disease-spread map ever since.¹¹⁵

Nearly every subsequent FMD plan (including recent USDA-APHIS documents) has included the 72-hour warning, citing a journal article or two from the early 1970s. Those studies showed that FMDV can, in fact, be found in the nasal passages of a veterinarian long after examining a diseased animal. Only many years later did scientists much question the procedures that made that finding seem clinically significant (a breach of GRADE-style reasoning). For example, the most-often cited experiment showed that virions in vets' noses were transmissible to livestock, but only by challenging FMDV-exposed vets to sneeze, snort, cough, and breath continuously, directly into the face of susceptible animals for at least 30 seconds, as long as they comfortably could. Even then, just one steer was reported to have shown signs of having been so infected.¹¹⁶

Efforts to replicate such a result under closer-to-ordinary conditions have so far failed. For example, a 2004 study found that a vet who simply washed hands and changed coveralls could go directly from fully examining a diseased animal to examining a naïve one, without transmitting disease or measurable immune response. Added precautions, like showering (much less three days of isolation) were demonstrably unnecessary. Subsequent restudies confirm that the risk of spreading FMDV via exhalation of people who have shared air with infected animals is “low” and that simple hygiene (wash hands, change coveralls) should suffice to keep responders safely on-duty, even if FMDV could still be detected in their noses. So, in this important instance – once relevance, quality and clinical significance were duly considered – hallowed, “evidence-based,” “commonsense” precautions proved to yield benefits that were unlikely to justify their cost.¹¹⁷

A related study of farm C&D is worth attention because it so affirms the lessons of human healthcare experience: the importance of realistic, confidence-graded, outcome-oriented tactics.¹¹⁸

A team of veterinary researchers from Iowa State University and the USDA Agricultural Research Service (ARS) conducted an experiment to measure the reduction in *Salmonella enterica* that would go with hundreds of pigs to slaughter (and then to pork) by cleaning and disinfecting their holding pens. They could readily document success reducing pathogen in all the pens that they treated, but not consistently in the pigs themselves. (There were 90-95 pigs per pen.) In fact, the pathogen count was lowered in pigs from just one of four pens. That result – in effect, a 25% reduction in risk of disease – could seem encouraging, but twice as often – 50% of the trials – the prevalence of *Salmonella* was actually significantly **higher** in pork from pigs in treated pens than from pigs in untreated pens.

Pathogen Detection, C&D, and Disease Transmission¹¹⁹

If only the floor samples had been collected, we might have falsely concluded, on the basis of biological feasibility, that the prevalence [of S. enterica] in swine was likely to have decreased. By concentrating on the outcome of interest – the prevalence in pigs – this error was avoided. This study demonstrates that simple cleaning and disinfection of lairage pens in itself is not a feasible intervention method for reducing the postharvest prevalence of S. enterica in pigs in the modern lairage environment and highlights the need for a better understanding of the ecology of S. enterica in the lairage environment.

– Schmidt et al. (2006)

When challenged to explain how decades of prior studies in peer-reviewed publications could have left them unprepared for such an outcome (that environmental C&D could be ineffective or even counter-productive in disease control), the researchers offered: “The most likely explanation . . . is that biases have distorted the outcomes of these studies. Many of the studies were case-control studies, case reports, or cross-sectional studies, so recall bias, selection bias, and uncontrolled confounding might explain differences in outcomes.”¹²⁰

In planning for emergency outbreaks, then, tactics with proven, practical health benefits need to occupy center stage, even when they challenge conventional wisdom. Alas, little proof of this sort exists for farms in particular. There are many more for human healthcare settings, but their quality and results are mixed. So far, they tend to suggest that the clinical benefits realizable through

C&D of environmental surfaces – actual decrease in indirect disease transmission – are limited. There is no particular, “science-based” height for the biosecurity bar. Once again, findings counsel a flexible mix of tactics.¹²¹

ADJUST TACTICS AS RETURNS DIMINISH

The biosecurity ideal – keep pathogens away from hosts – remains worth embracing but also, judging from farm and hospital experience, inescapably fallible (and occasionally harmful) in practice. The rewards of **particular** infection-control tactics cannot be reliably foretold, at least for indirect sources of contamination. Each precaution has potential costs and risks as well as gains that may increase with the fervor of its implementation. The net value of each may be tough to predict, but tactics must be selected sooner or later and a mix of benefits and losses realized in the end.

Even if no one tactic is singularly key, risk of disease surely could be reduced with a whole, versatile suite of them. In alliance with national stakeholders, New England authorities are promoting the full array of conventional biosecurity measures in dairy operations, but they are also preparing to throttle up or down the share of them that they will require (e.g., for permitting milk movement) as emergency circumstances allow. They do not plan to “bet the farm” (in this case, literally) on a particular set of much-advocated but unproven practices.

Again, judging from FAD and HAI experience, it is simply untrue that “more is better,” at least when it comes to targeting indirect vectors of contagion, fomites like wheels on hospital gurneys (or by implication, farm trucks). Most interventions seem to follow “Pareto’s Principle”: A very large share of benefits can be expected from relatively little effort. Beyond that – beyond the “point of diminishing returns” – even trivial gains are apt to be very tough to achieve or illusory. When resources are strained, as in an emergency, “80% effective” may well suffice.

Effort, Results, and the Point of Diminishing Returns¹²²

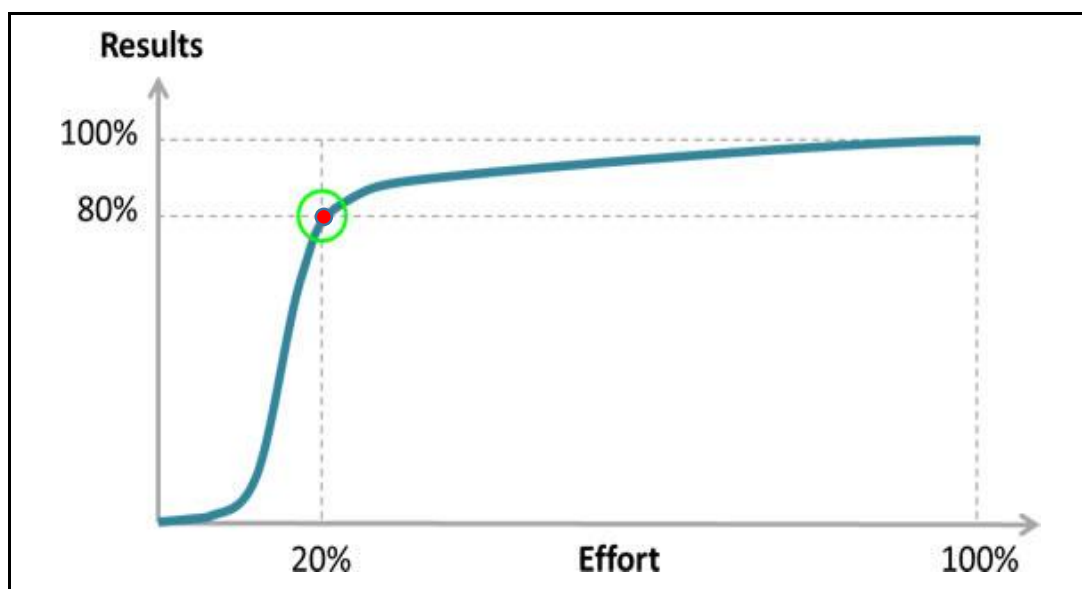

Pareto Principle: The 80/20 Rule¹²³

“20% of the input (times, resources, effort) accounts for 80% of the output (results, rewards)”

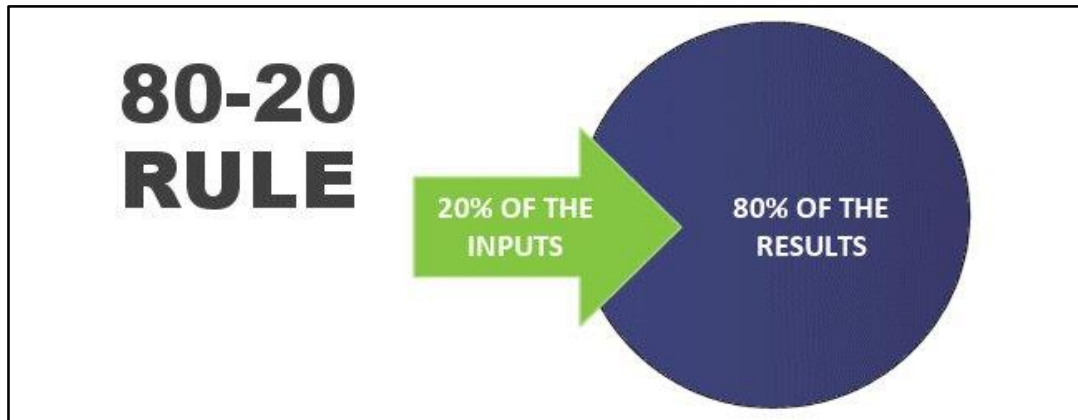

It is worth emphasizing that “80/20” is simply a rule of thumb. As with confidence-graded guidelines for healthcare facilities, **actual** “points of diminishing returns” should be determined from real-world experience, results of quality-controlled research on the variation in net outcomes as efforts increase. The shape of such “Pareto curves” can vary greatly. Researchers now commonly report that a 90/10 rule better fits their experience. About 10% of operations often account for 90% of the problems and potential solutions. Fixing a significant share of the remainder would rapidly deplete resources, with each increase in effort yielding radically lower returns: very little “bang for the buck.”¹²⁴

It should be no surprise, then, that professional managers aim to locate points of diminishing return precisely and to adjust efforts accordingly. Naturally, too, disputes about those points (e.g., which services fall above or below the breaking point? Whose services are worth funding?) are apt to be intense, as they have been in research and policy related to infection-control in healthcare settings.

Three broad areas of contention surrounding HAI also have special relevance for SMS planning:

- **Training and oversight of people who clean and disinfect,**
- **Use of approved contact times for disinfectants,**
- **Choice of disinfectant or detergent for environmental surfaces.**

TRAINING AND OVERSIGHT OF PEOPLE WHO CLEAN AND DISINFECT

Unlike most dairy farms, hospitals have the luxury of full-time administrators with extraordinary power to earn their keep. Adding just a point or two of return on investment can make a big difference in the bottom-line of a hospital budget, the patients’ experience, and executive compensation. More than government regulators, healthcare administrators can presume to captain a compliant chain of command. Insofar as collective bargaining agreements allow, they can “direct” layers of staff to follow the flavor-of-the-month infection-control routine. If anticipated results (such as a decline in the frequency of HAI) do not follow, administrators can discipline housekeepers or floor supervisors or just disavow the protocol. Heads will roll, and staff will either get on board or expect repercussions. (A review of the history suggests, “Rinse and repeat.”)

As awareness, consequences, and costs of HAI mount, so can tensions among affected personnel. Even with remarkable incentives and capacity, managing around points of diminishing return can also be expected to incite disputes about best practices and conflicts among the people who make and who are subject to their selection. Such conflicts set a contentiousness tone to the production and reception of a large and expanding body of related research.¹²⁵

Findings are often conflicted, but they tend to confirm that success in infection control is less a matter of **what** is done than **how** it is done: the “thoroughness” with which protocols are followed. Failures are regularly traced to small but consequential breaches in a “standard procedure.” It could be most anything, such as missing a spot when wiping a phone or carelessness in donning gloves. The problem is less in the selection or refinement of procedures than in the diligence of their execution. They are all close to commonsense, perfectible in theory and fallible in practice. Every hospital has well-vetted infection-control protocols, in-service training, and layers of oversight, but still some things – on average, research shows, about half – are not just improperly treated; they are missed entirely.¹²⁶

Thoroughness of Cleaning in Hospitals¹²⁷

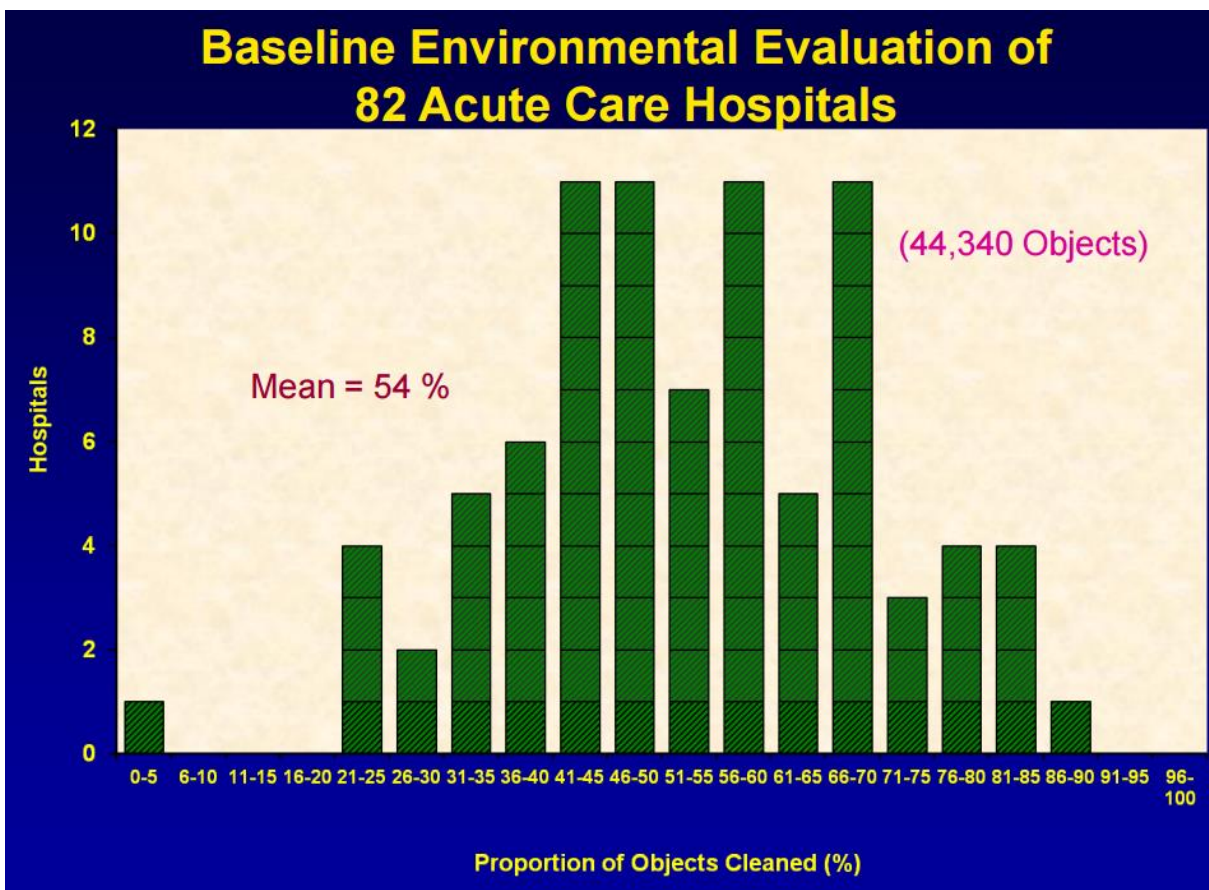

So, managers have developed and researchers tested a large, ever-changing arsenal of training and oversight practices to prevent such failures. In addition to the usual monitoring of environmental surfaces and patient records, they have tried an impressive array of “cultural” interventions – pep talks, certification programs, surveillance regimens, rewards and punishments to induce compliance. They aim to put thorough, consistent cleanliness closer to the center of hospital geist.¹²⁸

Evaluating Patient-Zone Environmental Cleaning: Exemplary Methods and Benefits¹²⁹

Method	Ease of Use	Identifies Pathogens	Accuracy	Useful for Teaching	Use in Programmatic Monitoring
Direct observation	Low	No	Variable	Yes	Difficult
Culture swab	High	Yes	High	No	No
Agar culture system	Moderate	Possible	Moderate	No	Possible*
Fluorescent system	High	No	High	Yes	Yes
ATP Bioluminescence	High	No	Variable	Yes	Possible*

* Measures cleanliness at that moment but **NOT** the process of cleaning

Although each measure has its champions, documented results seem again to be mixed and successes short-lived. No matter what the protocol or the mode of training and oversight, benefits (e.g., reduction in HAI frequency) peak somewhere between 10% and 70%. Most often it peaks at the low end of that range (on the wrong end of The 80/20 Rule – tough with meager benefits) and drops quickly as the novelty fades and other urgencies arise.

Tactics intended to raise the baseline “culture of thoroughness” seem to yield lasting benefits only beyond points of diminishing returns. Proponents can cite case studies that prove that their favorite intervention belongs on the “worth-it” side of a Pareto curve, while skeptics (and most subsequent reviews of the literature) place it on the other. In the meantime, researchers are looking into robotics and materials science, technologies that seem less dependent on housekeeping culture, but most administrators are not yet convinced they are worth the cost, either.¹³⁰

USE OF APPROVED CONTACT TIMES FOR DISINFECTANTS

Thanks to a couple of decades of mass marketing, products that are called “disinfectants” or “sanitizers” seem less intimidating than the class of chemicals to which they officially belong: “pesticides.” These agents are regulated to assure that they do precisely what they are supposed to do, which is a specific sort of harm to a specific sort of pathogen, parasite, or pest. From the user’s perspective, they must be “safe and effective when used as directed.” Otherwise, if produced, packaged, stored, transported, discarded, or applied improperly (“off-label”), they could be dangerous. They could miss their target and injure the applicator or the environment. To reduce such possibilities – whether in hospitals, farms, or factories, whether sold in familiar, branded jugs or scary-looking drums – pesticides are the focus of a complex, regulatory regime.

For example, all pesticides must be researched – generally, by the manufacturer seeking to market the product – in compliance with reams of government, lab- and litigation-tested rules. Results, including technical information about the contents, cautions, and directions, must be

elaborated in a Material Safety Data Sheet (MSDS) and summarized on the product label. The research and rules are overseen by an array of local, state, and federal bureaus that struggle to stay in synch with each other and to keep up with the usual avalanche of “new” pesticides and claims about them. (By registering these products with EPA, manufacturers limit their liability. In effect, they shift it to the taxpayer.)¹³¹

For example, each level of disinfectant (low-, intermediate, or high-level, in CDC parlance) must be laboratory-proven to slay a particular sample of microbes – the “benchmark organism” – that is the approved representative of the corresponding class of targets. Disinfectants like those registered for use in hospitals (or for deactivating FMDV) must reduce the population of the benchmark organism by a specified ratio (e.g., 10^{4-6} , a.k.a. “4-6 LRV,” the Log Reduction Value) within a minimum period (e.g., 10-30 minutes of “exposure,” “dwell” or “contact time”) at a given temperature and potency. Using it in a different dilution or shorter contact time constitutes a violation of U.S. law: The Federal Insecticide, Fungicide and Rodenticide Act (FIFRA). So, for example, staff in hospitals, farms or factories may use sodium hypochlorite (a.k.a. “bleach”) as they wish in the family laundry but can be prosecuted for using it off-label at work.¹³²

Such regulations add heat to the debate about contact times that are mandated on the label versus those that may seem best for a particular job. According to the FDA and EPA – with the exception only of approved alternatives (demonstrated by end-users and confirmed by regulators) – contexts are beside the point. Requirements are clear-cut. For example, if you are going to use a disinfectant to control infection in a healthcare (or agricultural) environment, it has to remain “in contact” – stay wet, in the right concentration on a surface that is free of visible contaminants – at least as long as the label says.

The USDA anticipates that an extraordinary number of people may need extraordinary latitude to use disinfectant in response to a FMD emergency. They do not want to wait for an actual outbreak, when useful applications could be on the edge of “off-label” and the need for permission would be urgent. So, they requested from EPA and gained a special exemption under FIFRA to allow ordinary dairy employees to use citric acid for cleaning things like truck tires. (Citric acid is an environmentally friendly, mild, organic, “low-level disinfectant” that is naturally found in fruits. It is a common ingredient in cosmetics and foods, such as soft drinks and ice cream. In the right concentration, it also has a pH that deactivates FMDV.)

Even then, while granting USDA’s request for a FIFRA exemption, the EPA insisted on some strikingly restrictive instructions on the label:

*Surfaces must be pre-cleaned by removing extraneous organic matter, such as with detergent, rinsing, and drying. Prepare solution by dissolving solid citric acid in soft, moderately hard, or hard water containing no more than 400 ppm soluble salts. Apply 3% citric acid solution on pre-cleaned porous food and non-food contact surfaces for 30 minutes. Apply 3% citric acid solution on pre-cleaned non-porous food and non-food contact surfaces for 15 minutes. Reapply solution if necessary, so that surface remains completely wet for applicable contact time.*¹³³

It is hard to imagine hundreds of farms fully complying with such directions every time a vehicle shows up at the farm gate. How could anyone keep a tank truck or a tractor “completely wet” for 15-30 minutes on a dog day of summer or in the dead of a New England winter? Or the proper dilution in a driving rain? In addition to time for pre-cleaning and drying, on the way in and out, at least 30-60 minutes would be added to each milk-tanker stop, just for disinfectant dwell time. Are such long contact times really necessary, anyway?

Similar questions of efficacy and feasibility have long prompted debate in human healthcare settings, too. The feasibility issue first came to attention with recognition that – at normal room temperatures and air-exchange rates – water-based disinfectants dry in less than two minutes, but the label on those same disinfectants requires that surfaces remain wet for ten minutes or more. So, housekeepers would have to reapply disinfectant at least five times per use. Apart from the sheer labor and expense would be the time that equipment or whole areas would be out of service, plus the added risk of slips and falls (e.g., when washing floors).

In the latest U.S. *Guidelines for Disinfection and Sterilization in Healthcare Facilities*, the CDC Healthcare Infection Control Practices Advisory Committee (HICPAC) put it plainly: “The contact time specified on the label of the product is often too long to be practically followed.”¹³⁴

Just as important, at least in “non-critical areas” (those that do not directly contact open wounds or mucous membranes), there seems to be no evidence that mandated contact times contribute to anyone’s health. (Dwell time requirements on labels are mainly based on lab work rather than field tests or clinical outcomes.) HICPAC reports an “apparent disconnect between label instructions and what studies show. . . . Multiple scientific papers have demonstrated significant microbial reduction with contact times of 30 to 60 seconds There are **no** data that demonstrate improved **infection prevention** by a 10-minute contact time versus a 1-minute contact time.”¹³⁵

Of course, regulators, manufacturers, and managers as well as their insurers could have their own reasons for requiring extended contact times. Concerns about liability yet again encourage erring on only one side of infection control: the more aggressive the better. They may well reason, “If one minute of contact time has been shown to be effective, you might as well require ten.” Bloating the lab-tested (but clinically unproven) minimum could be seen as a demonstration of “due diligence.” In any case, FIFRA rules. Hence, from a liability and bench-science perspective, longer contact times may be considered better even if they are demonstrably worse – risky, costly, and ineffective – from a more comprehensive, pragmatic and patient-centered point of view.

The current CDC *Guidelines* toe a fine line between these two perspectives. After highlighting the feasibility and efficacy problems of on-label contact times, HICPAC concludes that health care facilities should use shorter times, albeit at their own risk:

By law, users must follow all applicable label instructions for EPA-registered products. Ideally, product users should consider and use products that have the shortened contact time. However, disinfectant manufacturers also need to obtain EPA approval for shortened contact times so these products will be used correctly and effectively in the health-care environment.

Lest this contradiction between law and practicality seem daunting, HICPAC advises,

We are not aware of an enforcement action against health care facilities for ‘off label’ use of a surface disinfectant. . . . Thus, we believe the guideline allows us to continue our use of low-level disinfectants for noncritical environmental surfaces and patient care equipment with a 1 minute contact time.

In other words, stand duly warned, but do what’s right, use shorter times, and EPA can be expected to look the other way.¹³⁶

Contact Time for Disinfectants in Practical Applications¹³⁷

Another critical area for research includes the need to influence regulation as related to contact time. Currently, regulatory approval is based on efficacy of the product under conditions not reasonably found in healthcare settings. Approval of products for effectiveness under the conditions in which they are intended is needed. While the rationale of going above and beyond what is needed may be appealing, the practical applications and costs of pursuing unnecessary rigor is detrimental to the economics and efficiency of health care without gaining any benefit to patient safety.
– Carling and Huang (2013)

When it comes to contact times for disinfectants in a FMD emergency, it is hard to imagine that farms should be bound to comply with on-label minimums more strictly than research finds effective, than the CDC condones or hospitals actually use every day.¹³⁸

USE OF DISINFECTANT ON ENVIRONMENTAL SURFACES

Given flaws in conventional wisdom about disinfectants – exaggeration of their benefits and feasibility in environmental applications – healthcare administrators and researchers are asking tougher questions about their proper role in infection control.¹³⁹

Workplace warnings about hazards and improper application have become routine. For example, it is now commonplace to warn staff to protect eyes and skin around even low-level disinfectant. Mops and buckets need frequent care and changing, because they can spread as well as cull contaminants. Moreover, since organic material is an inhibitor, disinfection can only be as effective as the cleaning that precedes it. This is especially important since housekeepers may be tempted to count on disinfectant to make up for lax pre-cleaning. In fact, it has no such power, but plain old soap and water can be remarkably effective on their own.¹⁴⁰

It is well-documented that detergent can reduce all but the most resistant microbes by about 80%, a figure that would make Pareto smile. (It is worth emphasizing, though, that thoroughness still matters. For example, if an applicator misses 50% of a surface, as has been observed in ordinary circumstances, benefits also drop by half – down to 40% – likely leaving most pathogens not only in place but also embedded in matter that disinfectants will not penetrate, either.)¹⁴¹

Moreover, detergent is certainly less hazardous to use or to be around than any disinfectant. It does not require FIFRA compliance, an EPA-approved MSDS or warning label, special storage, transport or disposal. Even when preceded by perfectly thorough cleaning, disinfectant would kill no more than an additional 10-20% of pathogens (with presumably less net gain for surfaces that were not thoroughly pre-cleaned, for resistant microbes, or for enveloped viruses, against which detergent is more than 80% effective, anyway). So, in most cases it is reasonable to ask if the additional trouble, cost and risk of adding disinfectant are worth it.¹⁴²

Such questioning has, in fact, become intense for one particularly important element of healthcare facilities: floors. That focus also seems worth considering in an agricultural context because on-site precautions have comparable significance. Just as livestock pathogens can ride with traffic through the farm gate and down the lane, human pathogens can stride through the lobby or roll

through the emergency entrance and down the hall. Floors resemble dairy lanes or tankers in that they can become giant caches of contaminants, a mere touch or snort away from transfer to susceptible hosts. Hospitals, like farms, rely on detergent plus or minus disinfectant to lighten the “microbial load.”¹⁴³

In agriculture there has been relatively little question that cleaning can only be enhanced when followed by disinfection. The addition is usually just assumed to be worth it.¹⁴⁴ But in human healthcare such reasoning has fallen from grace. Debates about the best way to treat floor-born contamination has become so spirited that it has earned the nickname “Floor Wars.”¹⁴⁵ The ammunition comes from staff experience and dozens of studies in decades of peer-reviewed publications with claims like those summarized below.

Disinfectant versus Detergent in Cleaning Floors of Healthcare Facilities¹⁴⁶

CRITERION	DETERGENT	DISINFECTANT
Recommended Use	Recommended for removing organic material (e.g., ordinary “dirt,” grease, spilled food). Ineffective against bacterial spores (e.g., <i>C. difficile</i>).	Recommended for deactivating infective microbes as in blood or other body fluids. Ineffective in the presence of organic material/soil/debris.
Target Surface	Effective on noncritical surfaces (which contribute minimally to endemic HAI and its transmission).	Effective on both noncritical and critical surfaces (which may contribute to endemic HAI and its transmission). Recommended for patients with isolation precautions.
Microbial Effect	Removes rather than kills most microbes of HAI concern. About 80% reduction in population.	Kills most pathogens and reduces the microbial load on floors. 93-99% reduction in population.
Ease of Use	May require careful scrubbing, changes of wash water, wipes, mops or cloths and ample rinse for full effect.	Requires pre-cleaning for full effect. May save the effort of changing agents in moving from less to more critical surfaces (e.g., floors to equipment).
Aesthetics	Yields clean-looking, shiny floors.	May dull or damage some floors.
Cost	Low cost.	Higher cost.
Persistence	No persistent antimicrobial effect. Vulnerable to contamination that could seed and feed bacteria in the patient’s environment.	May have persistent antimicrobial effect. Less vulnerable to contamination.
Occupational Safety	Negligible occupational-health risks with exposure.	May be toxic or pose significant other risks to occupational health.
Disposal	No restrictions on disposal.	Disposal is restricted. May contribute to the evolution of antimicrobial-resistant bacteria.

As usual, each finding has its caveats, but they tend to get muddled or lost in the heat of battle. Instead, Floor Warriors are apt to claim that the latest monograph yet again “suggests” that their way of treating floors is superior and that opponents are misguided or worse. Consensus forms

mainly around the hope that research in the future will settle the matter once and for all. But there is little sign that will happen anytime soon.¹⁴⁷

Often combatants cite the very same studies to support opposing conclusions. Nearly everyone, for example, recalls a couple of landmark articles published about a half-century ago, as if they plainly prove his or her point, no matter what it is. The originals themselves seem to counsel such confusion. In 1966, for example, a much-cited group of infection-control experts, Ayliffe *et al.*, review existing literature and their own research on the subject to conclude:

*Because of the apparent failure of disinfectants to disinfect, some authorities hold that it is probably not worthwhile using them for the cleaning of floors except when there is severe contamination. . . . There is uncertainty about the role of floor bacteria as a source of hospital infection, but it is rational, when practicable, to prevent the establishment of reservoirs of pathogenic bacteria and to remove such reservoirs. The majority of disinfectants tested at the chosen concentration appeared to be highly effective in this respect.*¹⁴⁸

But just one year later, Ayliffe *et al.* recall the point of that very same article, their own, in a strikingly different way:

*From this study we deduce that at most times daily disinfection contributes little or nothing to the bacteriological cleanliness of ward floors. . . . Neither washing nor disinfection can be expected to remove the heavy bacterial colonization that is found on moist areas of exposed plaster of walls, or on damaged floor surfaces.*¹⁴⁹

Floor Wars are fraught with such conflicting testimony.

Probably the whole matter could be put to rest if someone would demonstrate that one agent had better, real-world results than another (not just fewer contaminants detectable on floor swabs but also fewer or less severe cases of HAI in patients). There have been dozens of elaborate efforts to find such evidence, but so far they have not found any.¹⁵⁰

No matter how long and hard they have looked, researchers have observed that disinfection of non-critical surfaces does not make any practical difference. Yes, at least momentarily it reduces the microbial load. Results look promising under a microscope and in theory, but disinfected floors have not yet been shown to protect patients' health any better than floors that are cleaned with detergent alone. Insofar as either agent has proven superior, it has been by increasing the frequency and diligence of mopping rather than the toxicity of pesticide in the bucket.¹⁵¹

Even proponents of disinfectant admit:

*Minimal risk has been associated with transmission of infectious agents to individuals through noncritical environmental surfaces such as furniture and floors, when they do not contact broken skin and/or mucous membranes. . . . There are no studies which have found differences between infection rates when floors are cleaned with detergents rather than disinfectants. It can be concluded that routine cleaning with a detergent is sufficient to prevent disease transmission from noncritical environmental surfaces.*¹⁵²

No matter what the type of pathogen, population or facility, even after months of controlled comparison, researchers have been unable to document improvements in patient health as a result of using disinfectant (vs. just soap and water) on floors in healthcare facilities. In fact, it has occasionally been shown to make matters worse. Nevertheless, for decades, researchers have begun (and often ended, despite contrary findings) with an assumption that is close to commonsense as well as deep conviction, especially among specialists of a bench-science or

modeling bent. To put in plainly: If you want people (or livestock) to be free of disease, rid their environment of the microbes that cause it. Wash off as much as you can, and kill the rest. That is what C&D is for. Supposedly.

The principle makes sense, and anyone who denies it is apt to be considered misguided, weak-willed, or dumb. Witness, for example, the uproar in 2002, when the CDC circulated its then-new draft *Guidelines for Disinfection and Sterilization in Health Care Facilities* for comment. The authors – members of the Healthcare Infection Control Practices Advisory Committee (HICPAC) – recommended disinfectant for floors, but they also admitted mounting evidence that it poses some environmental and occupational risks and that there is no empirical evidence that patients are thereby freer from infection than they are without it. The best that the authors could offer (admittedly “with low to very low quality evidence”) was, in effect: Yes, disinfected floors don’t appear to reduce infection, but we still think that it could. It makes sense, and it’s not that big a deal; so, heck, why not? It’s “reasonable.”¹⁵³

Expert response was swift and fierce, beginning with a letter of protest, published in the prestigious *American Journal of Infection Control*, signed by 36 specialists (including Ayliffe) in 18 countries. They asserted that regular, wholesale use of disinfectant **is** actually a big deal and that the research record – a large number of diverse studies reaching the same conclusion, without exception – deserves confidence, even if the implications are counter-intuitive. Disinfecting floors is not “reasonable,” they wrote, precisely because it is not clinically effective and because it endangers staff health and encourages the evolution of resistant pathogens, including those that foster HAI. There were also more or less blunt accusations that CDC authors were beholden to disinfectant manufacturers. Several subsequent reviews concur.¹⁵⁴

Clinical Outcomes of Environmental Disinfection in Hospitals¹⁵⁵

Does disinfection of environmental surfaces influence nosocomial infection rates? A systematic review

Markus Dettenkofer, MD,^a Sibylle Wenzler, MD^a, Susanne Amthor,^a Gerd Antes, PhD,^b Edith Motschall,^c and Franz D. Daschner, MD^a
Freiburg, Germany

Objective: To review the evidence on the effects of disinfection of environmental surfaces in hospitals (as compared with cleaning without use of disinfectants) on the occurrence of nosocomial infections.

Methods: Systematic review of experimental and nonexperimental intervention studies dealing with environmental disinfection or cleaning in different health care settings.

Results: A total of 236 scientific articles were identified. None described a meta-analysis, systematic review, or randomized controlled trial. Only 4 articles described completed cohort studies matching the inclusion criteria. None of these studies showed lower infection rates associated with routine disinfection of surfaces (mainly floors) versus cleaning with detergent only.

– *American Journal of Infection Control*, 2004

HICPAC members countered that “independent” collaborators agree with them and that research on downside risks (e.g., environmental and occupational health hazards) is hardly definitive, either (though they still do not dispute findings that show no significant change in HAI frequency or severity with use of disinfectant.)¹⁵⁶

Despite such differences in interpretation, fans as well as foes of floor disinfection agree that evidence and guiding principle are at odds. Experience and research challenge confidence in environmental microbicide, at least when it comes to floors in healthcare facilities. The difference in interpretation of those findings is more a matter of faith or bias than empirical science.¹⁵⁷

Fans of disinfection keep the faith, while foes are more open to heresy/reform. One agent – detergent alone – can better remove rather than kill most pathogens, but it has proven easier, cheaper and safer to use as well as effective (albeit imperfect) in protecting patient health. The other – detergent plus disinfectant – can better deactivate pathogens, but it has proven tougher to use, more expensive and hazardous as well as no better in controlling disease (again, at least in this one, albeit common, field-tested application).¹⁵⁸

So, researchers and administrators still have reason to disagree about the best way to treat floors, and policies differ around the world. For example, most healthcare facilities in the U.S. still opt for a combination of detergent and disinfectant. However, elsewhere (e.g., in England) they do not, and advice from the CDC remains ambiguous.¹⁵⁹

In agriculture, too, faith in environmental disinfection seems unshaken despite weak evidence, insofar as it exists, that farms are thereby any better protected from highly contagious disease. Biosecurity orthodoxy runs deep, no matter how often it fails. The most common, default position – a waffle – seems strikingly like that of the CDC since 2002, sticking to principle while admitting it is unproven.

Consequences of the Use of Disinfectant to Lower Microbial Loads¹⁶⁰

This study showed no significant synergistic, or additive, effect between detergent and disinfectant; despite this, it is still broadly recommended to apply both during cleaning of animal housing.

– Hancox *et al.* (2013)

There are two more major arguments against routine use of surface disinfectants in healthcare facilities: occupational health and environmental protection. . . . If we advocate soap and water for hands, we should also allow soap/detergent and water for cleaning environmental surfaces in hospitals.

– Allerberger (2002)

So, the tactical choice of disinfectant over soap and water to prevent farm infection should not be considered simply “reasonable.” It is a very contestable call.¹⁶¹

Nevertheless – again given the difference between human-healthcare and livestock facilities – it is hard to imagine that the fate of farms in an emergency should be more bound to disinfectant than research supports, the CDC condones, or hospitals require every day. It may seem “reasonable” to encourage full decon at farm gates, but analogous experience in hospitals (as well as recent outbreaks) suggests that it is unlikely to yield better protection from disease than

simpler precautions: coveralls, boots, hands, and minimized traffic. For essential vehicles, thorough cleaning with detergent has at least as strong a record of clinical effectiveness, and it is safer, cheaper, and easier to do. Reasonable as it may seem, adding disinfectant and certified applicators to permitting requirements appears to be unlikely to advance FMD control and, in that sense, to be worth it, much less worth requiring under all (versus select) emergency conditions.¹⁶²

IMPLICATIONS FOR FARM BIOSECURITY AND SMS PLANNING

Given the vagaries of disasters and the limitations of basic research (e.g., on FMD under actual farm conditions and on emergency management, virus containment, and infection control more generally), the costs and benefits of specific, truly feasible farm tactics are uncertain.¹⁶³ Experts often stress the importance of particular measures, but they also admit little proven knowledge about paths of indirect transmission of FMD from herd-to-herd and about the vulnerability of those paths to roadblocks. Recall the judgement of Hagenars *et al* in 2011 that data from prior outbreaks (including 2001, the best available) are inadequate for determining how most herds became infected. Reviewers agree that estimates of the risks that contaminated milk tankers represent to dairy farms are overwhelmingly anecdotal and speculative. Recommendations for remediating the risk are weak – “Category II” in CDC parlance – at best.¹⁶⁴

Risk of FMD Spread by Milk Tankers¹⁶⁵

During the 2001 UK FMD outbreak, a small number (11, 1% of total cases) cases were attributed to milk tankers, despite enhanced biosecurity measures being implemented, including filters on the air outlets. However, it is not known whether these cases occurred due to failure of the biosecurity measures or other mechanisms.

– Gibbens *et al.* (2001)

An extensive literature review was conducted by the risk analyst to incorporate all studies and technical reports that evaluated the involvement of milk tankers in the spread of disease in past outbreaks. The conclusions from different studies were often contradictory and did not provide definitive answers. . . . Analysis of involvement of milk tankers and other milk collection vehicles in the spread of disease in past epidemics (1967/68) indicate the evidence was equivocal. . . . The evidence for fomite spread, and in particular the spread via vehicles and personnel [2001] is circumstantial and is based on field investigations of links between IPs [infected premises], rather than experimental or controlled studies. It has been common during an epidemic for much of the spread of disease to be described as local, which in reality means that the route by which the disease entered the farm is unknown.

– USDA-APHIS and CAHFS (2013)

There still is widespread faith in the notion that biosecurity – barriers and practices that people design to halt infection – **should** be effective, but there are strikingly little data on how well each of them actually works and, hence, how they should be prioritized in an emergency. There are ample data showing that cleanliness on both sides of the farm gate helps, at least up to a point. But more stringent practices (beyond minimized traffic, common sense, standard precautions, soap and water) may be no more effective in controlling infection. The best mix of particular

precautions depends on many conditions, including the severity of the outbreak, the resources available, and the microbes that are apt to fill the niche that sanitation leaves.¹⁶⁶

For example, one of the lessons emerging from the most recent HPAI and PED outbreaks is that vehicle C&D measures that once passed for stringent are failure-prone. Unlike milk tankers, vehicles for hauling livestock, on which large-scale pork and poultry producers depend, are likely to be direct (vs. indirect) sources of infection, and biosecurity regiments have been more stringent to match. Producers have long been using more exacting procedures and oversight, more comprehensive on-farm decon facilities, and more toxic disinfectants. Nevertheless, researchers are finding that pork and poultry farms are not doing enough to yield consistent results. They may need to do a lot more – e.g., bake-dry their trucks and idle them for hours or even days between trips – before they should expect to see actual improvement in health outcomes. In other words, a truly effective height for the biosecurity bar for pork and poultry may well be yet further beyond the reach of most dairy farmers, yet further past their point of diminishing returns.¹⁶⁷

It is, of course, true that, whenever an infection spreads, some breach in biosecurity has occurred. Establishing that fact requires no information beyond the pathogen trail itself. If infection has spread, there must have been a breach. (Finding deficient biosecurity the “cause” of contagion is a figment of circular reasoning, a tautology, like blaming insomnia for sleepless nights or color blindness for an inability to tell red from green.) “Learning” that biosecurity has failed or even how it failed in a particular instance leaves open the question of how it could best be avoided in other instances or whether it can be avoided at all.¹⁶⁸

Challenge of Decontamination of Farm Vehicles in an Outbreak¹⁶⁹

‘The challenge, in the event of an outbreak, is the need to swiftly decontaminate many large trucks and tractor-trailers that have carried infected animals or contacted infected premises, sometimes to or from areas where freezing temperatures make decontamination difficult,’ said Lori Miller, an environmental engineer with USDA, APHIS. ‘What’s more is the grueling process for first responders. Research from our Canadian partners shows the difficulty of effectively decontaminating a vehicle with what is currently a hand washing method. . . .Research from the Canadian Food Inspection Agency found that a hand washing method in cold temperatures took four hours to disinfect a single vehicle. Responders had to don cumbersome equipment, including respirators, because of the harsh disinfectant chemicals and potential exposure to disease.

– USDA-APHIS and CAHFS (2013)

Note for example, that the three biosecurity strategies challenged above (formal training and certification of C&D personnel, long disinfectant dwell times, and a preference for disinfectant over detergent alone) all target indirect, environmental sources of infection. They are also prominently featured in the Biosecurity Performance Standards (BPS) for the national SMS Project. They are among the animal-disease emergency practices that would be tough for most dairy farms to achieve and that are recommended or required in some jurisdictions for treating vehicles (specifically, milk tankers) at the farm gate in a Control Area. (Note, too, that the “Proactive Risk Assessment” on which the BPS were supposedly based was actually completed **after** the BPS for the Secure Milk Supply had been drafted. They began as permutations of standards drafted years earlier for the Secure Egg Supply Plan. They were precast pillars of

faith.) As illustrated above, the SMS risk assessment itself finds little relevant “science” to go on. It does counsel increased biosecurity but it has little to say specifically about tanker C&D and no empirical evidence on the feasibility, costs or benefits of ways it could be done under real-world conditions.¹⁷⁰

One of the studies that is most frequently cited as demonstrating the value of tanker C&D (Ellis-Iversen *et al.*, 2011, analyzing the 2007 outbreak in the U.K.) finds that rewards of wheel washing (not to mention whole truck decon) are barely worth noting. Rather than justifying stronger disinfectant, longer holding times, or more training and oversight of farm staff, the study suggests that the greatest protection came in minimized traffic, sequestered visitor parking, and separation of cattle from passing vehicles.¹⁷¹

Another study that is frequently cited in support of farm-gate C&D actually finds no significant relationship between the opportunities for truck contamination (the number and length of stops at other premises) and the infection of farms they serviced. Nevertheless, the authors reason that – since some farms got infected and some didn’t and since all were serviced by tankers – it must have been the way the farms treated those tankers that accounts for the difference. In other words, the study “finds” that C&D works by assuming that it must have, without evidence of difference in how trucks were treated or information on other tactics (e.g., keeping cattle away from trucks or things that touch them) that could just as conceivably yield the same effect. In any case, the authors insist, it is a combination of surveillance, agility, and imperfect measures tailored to the incident rather than any particular practice that appears to be most effective in controlling infection.¹⁷²

Pragmatism and Flexibility in Biosecurity¹⁷³

Farm gate biosecurity has always been emphasised during FMD outbreaks, but the reality is that, unless it is policed, it is frequently lax, particularly when there is an urgency about the activities involved, such as silage making. Equally, with some movements on and off farms (such as milk tanker collections) taking place around the clock and without supervision by the farmer, applying farm gate biosecurity becomes a difficult task. How can anyone adequately cleanse and disinfect a milk tanker at the farm lane end in the dark? Even properly cleaning and disinfecting a lorry in daylight with a pressure washer and disinfectant takes a relatively long time and is hard to do completely. Fortunately, farm gate biosecurity does not have to be perfect, just good enough. How good is good enough varies with the EDR [Estimated Dissemination Rate] without effective biosecurity and how much spread is indirect.

– Nick Honhold (2006)

One of the most ambitious of recently published, peer-reviewed simulations of FMD response yet again testifies that biosecurity (e.g., decon at the farm gate) **could** be a powerful determinant of the success of FMD-response strategy. However, the authors also lament that there is too little evidence – almost nothing beyond expert opinion (i.e., professional lore) – to estimate the actual effect. So, to run the model, rewards of biosecurity in reducing disease spread through indirect contact were “parameterized” (i.e., fabricated) by way of selection from a table of random numbers and then re-run with increases to that random number by round-number percentages (15-50%) to see “consequences” for disease extent and duration (“sensitivity analysis”). “Sensitivity” was

great, but obviously that result is a reflection of the placeholder built into the model and data that were whole-cloth fictions rather than anything found in the real world.¹⁷⁴

Of course, this is not to argue that current FMD-response or SMS plans and preparations will not work. An excess of skepticism is no more defensible than an excess of confidence. Unlike “Merchants of Doubt,” in service of the tobacco or fossil-fuel industry, this is not an instance of special interests seeding doubt about science and public policy.¹⁷⁵ Considered in the abstract, larger agricultural interests – intensive feeding, breeding, and milking operations, more common outside New England – might seem better able to afford more stringent biocontainment measures. But New England’s permitting plans do not favor operations of any particular scale. The distribution of Ratings of working farms in the region is independent of the number of cows they milk or pounds of production. So, a flexible mix of mandated precautions can contribute to the survival of both large and small farms that are so crucial to New England.¹⁷⁶

Guidelines developed to support Secure Food Supply projects have consistently stressed support for state and regional variation in strategizing common goals. Since “one size won’t fit all,” variation has been expected and so far welcomed. This analysis argues for the value of the variant that has evolved in New England and the relatively weak evidence for alternatives. It includes an emphasis on confidence-graded tactics, favoring those with proven health benefits, and readiness to shift tactics as returns diminish.¹⁷⁷ Regional preparations support biosecurity requirements that are agile and practical. Most of all, the region offers a distinctly feasible and flexible route to shared goals in an animal-disease emergency.¹⁷⁸

REFERENCES

- ¹ Plainly, this defense of the [New England Secure Milk Supply \(SMS\) Plan](#) is from a decidedly “New England point of view,” particularly since the author helped develop the plan itself, albeit while contributing to the [national SMS project](#) since its inception and to other states and regions in their SMS planning. Authors of other SMS plans have generously shared their drafts but have not yet approved more general circulation, excerpting, or citation. Hence, characterization here of those plans is informed by confidential drafts and intended to be accurate, but it is also inescapably contestable. Characterizations that are publicly available include: [Mid-Atlantic States SMS Project – Overview](#), slides for presentation at the 2014 USAHA Meetings, and Charles C. Broaddus, [The Mid-Atlantic Security Milk Supply Project](#), slides for presentation and abstract in [Proceedings of the 116th Annual Meeting of the USAHA](#), Greensboro, NC (October 18-24, 2012), pp. 134-135; [Secure Milk Supply for Wisconsin Preparedness Plan](#) (Draft May, 2014); Pam Hullinger, [Secure Milk Supply: Current Challenges and Industry Opportunities](#), Presentation at the NIAA Annual Meeting in Omaha, NE (April 2, 2014).
- ² See: Richard P. Horwitz, [Foot-and-Mouth Disease \(FMD\) as a Hazard for New England Dairies](#) (June 30, 2011) and [New England as a Jurisdiction for Supporting Continuity of Dairy Operations: A Reassessment](#) (December 30, 2013).
- ³ As of February, 2015, 1162 of 1720 (67.6%) dairy farms that appeared in licensure records of the six states were surveyed and assigned a Readiness Rating by a representative of the SAHO. Since some farms awaiting surveys in the interim may have ceased operation or been absorbed by another operation (the long-term trend), coverage may actually be higher. NESAASA data (February 10, 2015). See also: Richard P. Horwitz, [Assessing Farm Readiness for Emergency Milk Movement in New England](#) (August 1, 2014); [Updating Weights of Criteria in the Readiness Rating](#) (August 1, 2014); and [Readiness of New England Dairy Farms for SMS: A Snapshot, 2014](#) (August 1, 2014). The approach has a great deal in common with a simultaneous, independent effort in the swine industry that originated in 2006 in response to PRRS: The American Association of Swine Veterinarians (AASV) [Production Animal Disease Risk Assessment Program \(PADRAP\)](#). See, also: Boehringer Ingelheim, [PADRAP](#) (2015); Derald J. Holtkamp *et al.*, [Identifying Questions in the American Association of Swine Veterinarian's PRRS Risk Assessment Survey That Are Important for Retrospectively Classifying Swine Herds According to Whether They Reported Clinical PRRS Outbreaks in the Previous 3 Years](#), *Preventive Veterinary Medicine* 106:1(Sep 1, 2012), pp. 42-52.
- ⁴ The approach in the region could be characterized as “adaptive management” and “anticipatory governance.” Michael E. Gorman, Lekelia D. Jenkins, and Raina K. Plowright, [Human Interactions and Sustainability](#), in *Sustainability: Multi-Disciplinary Perspectives*, ed. Heriberto Cabezas and Urmila Diwekar (Oak Park, IL: Bentham Science Publishers, 2012), pp. 88-111. For details on the New England risks and remediation tactics, see: Richard P. Horwitz, [Assessing Farm Readiness for Emergency Milk Movement in New England](#) (August 1, 2014) ; Richard P. Horwitz, [Readiness Rating for Continuity of Dairy Operations in a FMD Control Area](#), poster for the 7th International Symposium on Emerginc and Re-emerging Pig Diseases, Kyoto, Japan (June 21-24, 2015); Richard P. Horwitz, [Readiness of New England Dairy Farms for SMS: A Snapshot, 2014](#) for NESAASA (August 1, 2104); Richard P. Horwitz, [Updating Weights of Criteria in the Readiness Rating](#), for NESAASA (August 1, 2014); Richard P. Horwitz, [Exercise Follow-up: Progress in Readiness Reviews for the New England Secure Milk Supply \(SMS\) Project](#), for NESAASA (February 26, 2014); and the supporting documents for producers, processors, and hauler linked under Attachments headed: “9. Resources for Assessing “Readiness” for Emergency Milk Movement,” on the webpage for the [New England Secure Milk Supply \(SMS\) Plan](#)
- ⁵ Richard P. Horwitz, [Assessing Farm Readiness for Emergency Milk Movement in New England](#) (August 1, 2014) and 2013-2014 exercise documentation, after-action reports, and follow-up research on the NESAASA website: <http://nesaasa.weebly.com/ne-sms-project.html>. Note that graded, ratio-level, weighted composite scoring of biosecurity is also used in much of the pork and poultry industry. In that respect, the “Readiness Rating” developed for dairies in New England resembles instruments that Perdue Farms uses in selecting its contract poultry producers and that members of the American Association of Swine Veterinarians (AASV) use in assessing the biosecurity of swine producers for the [Production Animal Disease Risk Assessment Program \(PADRAP\)](#). Derald Holtkamp (ISU and AASV), [Swine](#)

[Biosecurity Practices](#) and David Shapiro (Perdue Farms) [Poultry Outbreak](#), presentations at USDA Agricultural Research Service, [Third International Biosecurity and Biocontainment Symposium](#) in Baltimore, MD (February 4, 2015), and subsequent personal communications (February-March, 2015).

⁶ Data are from 1,162 farms surveyed to date (67.6% of the total number of farms in state licensure records). Note that the farm size and Readiness Ratings are not significantly related – Pearson Correlation Coefficient (r) = -0.017. The difference between large and small farms in New England is smaller than in other parts of the U.S., and their per-cow production and Readiness Ratings are similar. So, the cumulative share of farms and share of production that would be sustained via permitting by any given Readiness Rating would be very nearly identical. NESAASA data (February 10, 2015). Richard P. Horwitz, [Readiness of New England Dairy Farms for SMS: A Snapshot, 2014](#) (August 1, 2014), pp. 6-9.

⁷ Richard P. Horwitz, [Foot-and-Mouth Disease \(FMD\) as a Hazard for New England Dairies](#) (June 30, 2011), pp. 32-59. See also: Bob Parsons, [Vermont's Dairy Sector: Is There a Sustainable Future for the 800 lb. Gorilla?](#), *Opportunities for Agriculture Working Paper Series 1:4* (University of Vermont Center for Rural Studies, 2010); James MacDonald and Doris Newton, [Milk Production Continues Shifting to Large-Scale Farms](#), USDA Economic Research Service (December 1, 2014); James MacDonald *et al.*, [Profits, Costs, and the Changing Structure of Dairy Farming](#), USDA Economic Research Service (September, 2007); Gary Keough, [Trends in New England Agriculture](#), Presentation for the New England Field Office of USDA National Agricultural Statistics Service, (2010).

⁸ World Organization for Animal Health / Office International des Epizooties (OIE). "[Foot and Mouth Disease](#)," [Manual of Diagnostic Tests and Vaccines for Terrestrial Animals](#), Chapter 2.1.5 (2012), p. 1. Emphasis added.

⁹ See, for example: USDA-APHIS, [Standard Operating Procedures: 5. Epidemiological Investigation and Tracing](#), FADPRP (February, 2014); Raina K. Plowright *et al.*, [Causal Inference in Disease Ecology: Investigating Ecological Drivers of Disease Emergency](#), *Frontiers in Ecology and the Environment* 6:8 (October, 2008), pp. 420-429.

¹⁰ Through the [World Trade Organization](#) (WTO) [Agreement on the Application of Sanitary and Phytosanitary Measures](#) (SPS), OIE mandates such strategy for a list "[reportable](#)" or "[notifiable](#)" diseases. American officials have traditionally dubbed the highly contagious or zoonotic entries "Foreign Animal Disease" (FAD) even though pathogens do not themselves have nationalities. For example, USDA-APHIS defines a FAD as "a terrestrial animal disease or pest, or an aquatic animal disease or pest, not known to exist in the United States or its territories." The 2008 edition of the most authoritative U.S. book on the subject ("[The Gray Book](#)") suggests that "transboundary" (TAD) may now be a more appropriate modifier. John Clifford, [Policy for the Investigation of Potential Foreign Animal Disease / Emerging Disease Incidents \(FAD/EDI\)](#), VS Guidance 12001.2 (June 5, 2014), p. 2; Committee on Foreign and Emerging Diseases of the United States Animal Health Association (USAHA), [Foreign Animal Diseases](#), Revised 7th Edition (2008), pp. 17-18. See also: USDA-APHIS, [Foreign Animal Disease Preparedness and Response Plan](#) (May, 2012); USDA-APHIS [National Animal Health Reporting System](#) (NAHRS, 2013); USDA-APHIS, [Proposal for a U.S. National List of Reportable Animal Diseases \(NLRAD\): Concept Paper](#) (July, 2014)); United States, Office of the Federal Register, National Archives and Records Administration, "Possession, Use, and Transfer of Select Agents and Toxins," in [Agricultural Bioterrorism Protection Act of 2002; Possession, Use, and Transfer of Biological Agents and Toxins; Final Rule](#), USDA-APHIS, *Federal Register* 70:52 (March 18, 2005); 9 *CFR*, § 121.3.

¹¹ John Hammond, FMD World Reference Laboratory, Pirbright, U.K., reproduced by Wilna Voslo, [Foot-and-Mouth Disease: A Persistent Threat](#), (March 2013).

¹² World Organisation for Animal Health (OIE), [Foot and Mouth Disease \(FMD\)](#) (July, 2014). See also OIE's World Animal Health Information System (WAHIS), [Disease Distribution Maps](#) (2015) and Food and Agriculture Organization of the United Nations (FAO). [EMPRES-i Global Animal Disease Information System](#) (2015).

¹³ OIE recognizes FMD as "endemic" in 96 of the 178 nations that belong to the organization. Furthermore, despite well-known under-reporting, just from 2006-2011, OIE reported nearly two thousand outbreaks in another 42 countries. Emilio A León, "Foot-and-Mouth Disease in Pigs: Current Epidemiological Situation and Control Methods," *Transboundary and Emerging Diseases* 59:Supplement 1 (January, 2012), p. 45;

Sofia Boqvist, [Contagious Animal Diseases: The Science behind Trade Policies and Standards](#), *Veterinary Journal* 202:1 (October, 2014), pp. 7-10.

- ¹⁴ By contrast, Gavin R. Thomson *et al.* argue “for greater emphasis to be placed on value chain management as an alternative to geographically based disease risk mitigation for trade in commodities and products derived from animals. The geographic approach is dependent upon achievement of freedom in countries or zones from infectious agents that cause so-called transboundary animal diseases, while value chain-based risk management depends upon mitigation of animal disease hazards potentially associated with specific commodities or products irrespective of the locality of production. This commodity-specific approach is founded on the same principles upon which international food safety standards are based, viz. hazard analysis critical control points (HACCP). Broader acceptance of a value chain approach enables animal disease risk management to be combined with food safety management by the integration of commodity-based trade and HACCP methodologies and thereby facilitates ‘farm to fork’ quality assurance. The latter is increasingly recognized as indispensable to food safety assurance and is therefore a pre-condition to safe trade. The biological principles upon which HACCP and commodity-based trade are based are essentially identical, potentially simplifying sanitary control in contrast to current separate international sanitary standards for food safety and animal disease risks that are difficult to reconcile. A value chain approach would not only enable more effective integration of food safety and animal disease risk management of foodstuffs derived from animals but would also ameliorate adverse environmental and associated socio-economic consequences of current sanitary standards based on the geographic distribution of animal infections.” [International Trade Standards for Commodities and Products Derived from Animals: The Need for a System that Integrates Food Safety and Animal Disease Risk Management](#), *Transboundary and Emerging Diseases* 60:6 (December, 2013), pp. 507–515.
- ¹⁵ Assertions of this principle often cite a 20-year-old OIE assertion: “All trucks, trailers, and other vehicles used for transporting animals, animal products, products, feed, offal, and contaminated equipment are a potential risk in the spread of disease. Drivers should not enter farms or other animal production premises without good reason. Vehicles should be disinfected between farms. All feed, equipment and other goods should be unloaded outside the farm.” A. Mateos Poumian, [Disinfection of Trucks and Trailers](#), *Revue Scientifique et Technique* (OIE) 14:1 (March, 1995), p. 171. See also: W. B. Ford, [Disinfection Procedures for Personnel and Vehicles Entering and Leaving Contaminated Premises](#), *Revue Scientifique et Technique* 14:2 (June, 1995), pp. 393-401. More recent, kindred assertions include: James F. Lowe *et al.*, [Role of Transportation in Spread of Porcine Epidemic Diarrhea Virus Infection, United States](#), *Emerging Infectious Disease* 21:5 (May, 2014), pp. 872-874.
- ¹⁶ USDA-APHIS-VS, [Foot-and-Mouth Disease Response Plan: The Red Book](#) (September, 2014), Figure F-2, p. F-22. See also: USDA-APHIS, Foreign Animal Disease, [Ready Reference Guide – Zones, Areas and Premises in an FAD Outbreak](#) (August 2013).
- ¹⁷ USDA-APHIS-VS, [Foot-and-Mouth Disease Response Plan: The Red Book](#) (September, 2014). Note that in 2013, the American Veterinary Medical Association (AVMA) defined some situations where animals are killed – particularly slaughter and depopulation for disease control – “outside the purview” of its euthanasia *Guidelines*. Ethical and procedural recommendations were to “be addressed by separate documents that are under development.” A subsequent Draft of “AVMA Guidelines for the Humane Slaughter of Animals” has been approved by the Executive Board, but work has just begun on a separate document covering depopulation. [AVMA Guidelines for the Euthanasia of Animals: 2013 Edition](#), p. 5; Katie Burns, [AVMA Releasing Guidelines on Humane Slaughter](#), *JAVMA News* (March 1, 2014).
- ¹⁸ Barrett D. Slenning, [Keeping Foreign Animal Disease Programs from Eradicating Farm Communities](#), Presentation to the Colorado Veterinary Medical Association (CVMA) Annual Meeting (September 26, 2011). Haulers agree: “The American Trucking Associations researched seven key consumer industries to quantify the potential consequences of restricting or halting truck traffic in response to a national or regional emergency. . . . Conclusion: As demonstrated by the analysis of just a few key industries, restricting or shutting down all truck operations in response to a natural disaster, elevated threat level, terrorist attack, or pandemic will have a swift and devastating impact on the food, healthcare, transportation, waste removal, retail, manufacturing, and financial sectors. . . . At first glance, halting all truck travel appears to be a powerful tool to neutralize a terrorist threat or protect citizens from a pandemic.

However, this is a solution that could be worse than the problem. Instead, we must urge governments at all levels to develop contingency and action plans that use sophisticated techniques to isolate and respond to a threat.” American Trucking Associations (ATA). [When Trucks Stop, America Stops](#) (July 14, 2006), pp. 1, 6-7. See also: Barrett D. Slanning, and Jimmy L. Tickel, “Foreign Animal Diseases and Food System Security: Decision Making for Appropriate Responses,” *Wiley Handbook of Science and Technology for Homeland Security* (February 12, 2010).

¹⁹ In reviewing regulator’s response to FMD in the U.K. in 2001, The Royal Society for the Prevention of Cruelty to Animals found complaints about depopulation to be the most demanding and disturbing but also concluded: “Movement restrictions imposed as part of the disease control strategy caused major welfare problems on farms which were unaffected by disease.” Laurence, Christopher J. [Animal Welfare Consequences in England and Wales of 2001 Epidemic of Foot and Mouth Disease](#), *Revue Scientifique et Technique* (OIE) 21:3 (2002), p. 863.

²⁰ In testimony for one of the first investigations of the 2001 FMD outbreak in the U.K., veterinarian Wendy Vere dubbed the response “carnage by computer,” a characterization that stuck in official as well as journalistic reviews. See, for example, Iain Anderson, [Foot and Mouth Disease 2001: Lessons to be Learned Inquiry Report](#) (London: Stationery Office, London, 2002) and [Foot and Mouth Disease 2007: A Review and Lessons Learned](#) (London: Stationery Office, London, 2008); David Campbell and Bob Lee, [‘Carnage by Computer’: The Blackboard Economics of the 2001 Foot and Mouth Epidemic](#), *Social and Legal Studies* 12:4 (December 2013), pp. 425-429; European Parliament, Temporary Committee on Foot and Mouth Disease, [Report on Measures to Control Foot and Mouth Disease in the European Union in 2001 and Future Measures to Prevent and Control Animal Diseases in the European Union](#) (November 28, 2002); National Audit Office (NAO), [The 2001 Outbreak of Foot and Mouth Disease, Report by the Comptroller and Auditor General](#), HC 939 Session 2001-2002 (June 21, 2002); Royal Society, [Royal Society Infectious Disease in Livestock Inquiry Follow-Up Review](#) (December, 2004); and Abigail Woods, *A Manufactured Plague: The History of Foot and Mouth Disease in Britain* (Oxford: Routledge, 2004), pp. 131-145.

²¹ Committee on Foreign and Emerging Diseases, United State Animal Health Association (USAHA), [‘Foot and Mouth Disease,’ Foreign Animal Diseases](#) [a.k.a. “The Gray Book”] 7th Edition (St. Joseph, MO: USAHA, 2008), pp. 261-270; Robert Armstrong *et al.*, “Foot-and-Mouth Disease in Man,” *British Medical Journal* 4:5578 (December 2, 1967), pp. 529-530; Konrad Bauer, “Foot and Mouth Disease as Zoonosis,” *Archives of Virology* 13 Supplement (1997), pp. 95-97; David T. Harder and Larissa A. Minicucci (for Dairy Management Inc.), [Foot-and-Mouth Disease: Public Health Implications for Human Consumption of Pasteurized Milk](#), (November 7, 2008); Kiana Moore and Heather Allen, [Continuity of Business Plans for Animal Disease Outbreaks: Using a Logic Model Approach to Protect Animal Health, Public Health, and Our Food Supply](#), *Agriculture* 3, (April 23, 2013), pp. 253-270; Pam Hullinger, [The Importance of Building Business Continuity into Contingency Plans: The Example of FMD Continuity of Business Planning in the United States](#), Presentation at the 41st General Session of the European Commission for the Control of Foot and Mouth Disease (EuFMD) FAO Headquarters, Rome, Italy (April 23, 2015);

²² Tim E. Carpenter *et al.*, [Epidemic and Economic Impacts of Delayed Detection of Foot-and-Mouth Disease: A Case Study of a Simulated Outbreak in California](#), *Journal of Veterinary Diagnostic Investigation* 23:1 (January, 2011), pp. 26-32. For runs of economic and disease-spread models, they assume that FMD is confined to just one state but include its simulated costs elsewhere in the U.S. and in international trade. They conclude: “The median economic impact of an FMD outbreak in California was estimated to result in national agriculture welfare losses of \$2.3–\$69.0 billion as detection delay increased from 7 to 22 days, respectively. If assuming a detection delay of 21 days, it was estimated that, for every additional hour of delay, the impact would be an additional approximately 2,000 animals slaughtered and an additional economic loss of \$565 million.” See also: The FAZD Center, [The Hourly Cost of Delays in FMD Detection](#), YouTube Video (March 3, 2010).

²³ The perspective in the following draws from a more global perspective on risks and remedies in light of inequality of stakeholder resources, what FAO researchers have called “a more ‘people centred’ approach””: “This implies making the livelihoods of farmers and traders the primary objective of the actions taken by animal health systems, with the control of disease as a second and supporting objective. Most of the time these two objectives are very well aligned but the strategy for animal health could sometimes

be different if livelihoods were the primary focus. . . . Smallholders are constantly dealing with numerous constraints at the same time This means that they view the risk of diseases, including HPAI, differently from industrial producers. Most of the research done on the impact of HPAI has focused on the poultry enterprise alone, rather than considering it as part of the household's portfolio of income generating activities and assets. . . . The need to maintain many sources of livelihood means that smallholders will only consider measures proposed to reduce livestock disease risk, such as improved biosecurity, in the context of their entire approach to reducing risk to their livelihood. . . . Reflecting on the experience of HPAI and our improved knowledge of smallholder poultry keeping, it is obvious that changes are needed within animal health systems if they are to provide a better service to poultry producers, and particularly to improve emergency responses and make them less damaging to poor people's livelihoods and dignity. One way of approaching this is to make the livelihoods of farmers and traders the primary objective of the actions taken by animal health systems, with the control of disease as a second and supporting objective. Most of the time these two objectives are very well aligned but the strategy for control could sometimes be different if livelihoods were the primary focus. . . . The *laissez-faire* approach that prevails in peacetime and the top-down model that swings into place during a disease crisis would be replaced by something . . . [that] reflects the complexity of the real world. It includes a stronger two-way communication between farmers and veterinarians, both private and public, a more integrated approach to providing technical assistance and more concerted action at local levels. The international community is not primarily a driver of emergency response but a supporter during both peacetime and emergencies of co-ordinated initiatives that strengthen public and private service provision." Illia Rosenthal and Anni McLeod, [How Can Animal Health Systems Support Small-Scale Poultry Producers and Traders? Reflections on experience with HPAI, FAO Animal Production and Health Working Paper No. 10](#) (Rome, Italy: FAO, 2012), pp. xiii, 13, 24.

²⁴ See: Peter S. Dawson, "The Involvement of Milk in the Spread of Foot-and-Mouth Disease: An Epidemiological Study," *Veterinary Record* 87:19 (October 31, 1970), pp. 543-548; Nick Honhold *et al.*, [Control of Foot-and-Mouth Disease](#), *Veterinary Record* 168:20 (May, 2011), pp. 541-542; Nick Honhold, Tony Taucher, and Nick Taylor, "The Involvement of Milk Tankers in the Spread of Foot and Mouth Disease in Cumbria, 2001," The University of Reading (2004), Appendix 5 in [Detailed Investigation of the Methods and Characteristics of Spread of FMD in Specific Geographic Clusters and the Effects of Control Measures during the 2001 Epidemic](#), Final Project Report to DEFRA (2005); Nick Honhold, Tony Taucher, and Nick Taylor, [The Involvement of Milk Tankers in the Spread of Foot and Mouth Disease in Cumbria, 2001](#), Report for Veterinary Science Directorate (October 2004), and *International Symposia on Veterinary Epidemiology and Economics Proceedings 11: Proceedings of the 11th Symposium of the International Society for Veterinary Epidemiology and Economics (ISVEE)*, Cairns, Australia, Theme 6 - Global Response and Emerging Diseases: Foot and Mouth Disease Session, (August 2006), p. 396; Nick Honhold, [The Impact of Farm Gate Biosecurity on the Transmission of FMD in UK in 2001](#), International Control of Foot-And-Mouth Disease: Tools, Trends and Perspectives, 2006 Session of the Research Group of the Standing Technical Committee of the European Commission for the Control of Foot-and-Mouth Disease (EuFMD), Paphos, Cyprus (October 16-20, 2006), Appendix 3, pp. 26-34; Richard Paul Kitching, A. Marcus Hutber, and Michael V. Thrusfield, "A Review of Foot-and-Mouth Disease with Special Consideration for the Clinical and Epidemiological Factors Relevant to Predictive Modelling of the Disease," *Veterinary Journal* 169:2 (March, 2005), pp. 197-209.

²⁵ "An earlier study found that approximately 77 per cent of the known transmissions routes were animal transport related (Dijkstra 1955). If this number is extrapolated to the FMD outbreak in the UK in 2001, the ban on animal transport would have resulted in a between farm reproduction number of 0.8 (23 per cent of transmission not caused by animal movements of 3.3 farms). Although these numbers should be interpreted with care, they possibly suggest the development of new transmission routes after the implementation of control measures. Although illegal movement of animals cannot be excluded, the increase could be caused by an increased number of people moving between farms." Aldo Dekker, [Biosecurity and FMD Transmission](#), *Veterinary Record* 168:5 (February 5, 2011), p. 126, citing Jacob M. Dijkstra, *De Mond- en Klauwzeerepizoötieën in Friesland* [Foot-and-mouth disease in the Province of Friesland] ('S-Gravenhage [The Hague, NL]: Staatsdrukkerij Uitgeverijbedrijf [SDU], 1955).

²⁶ Kiana Moore and Heather Allen, [Continuity of Business Plans for Animal Disease Outbreaks: Using a Logic Model Approach to Protect Animal Health, Public Health, and Our Food Supply](#), *Agriculture* 3, (April

23, 2013), p. 256; United States Department of Agriculture, APHIS, National Center for Animal Health Emergency Management, [FAD PReP Strategy Document: Classification of Phases and Types of a Foot-And-Mouth Disease Outbreak and Response](#) (March 2013).

²⁷ With similar reasoning (assuming “every person is potentially infected or colonized with an organism that could be transmitted in the healthcare setting”) the CDC Healthcare Infection Control Practices Advisory Committee (HICPAC) recommends identical measures for infection prevention (“Standard Precautions”) and infection control (“Transmission-Based Precautions”) of environmental surfaces in hospitals and clinics. The CDC, [Guideline for Isolation Precautions: Preventing Transmission of Infectious Agents in Healthcare Settings](#) (2007), pp. 77-90.

²⁸ See, for example, Commission of the European Communities. [White Paper on Food Safety](#) (January 12, 2000). Principles and procedures for cow-to-consumer traceability have already been sanctioned by the USDA final rule for [Traceability for Livestock Moving Interstate](#) (ADT, 9 CFR Parts 71, 77, 78, and 86, January 9, 2013) and the FDA [Food Safety Modernization Act](#) (FSMA, Public Law 111–353, January 4, 2011) which has been endorsed sufficiently to cover 20% of U.S. dairy production through a “U.S. Dairy Traceability Commitment.” See also: USDA-APHIS, [Animal Disease Traceability](#) (November 18, 2014) and [Innovation Center for U.S. Dairy, 21-Point Enhanced Dairy, Traceability Checklist](#); and [Guidance for Dairy Product Enhanced Traceability: Voluntary Practices and Protocols for Strengthening the U.S. Dairy Supply Chain](#) (September, 2013). Recognizing the value of health surveillance and response-ready information, New Zealand is developing and “Incursion Response System” (IRS – an integrated web- and map-based information system for animal-disease-emergency response teams) that uses the Ministry of Agriculture and Forestry (MAF) database – FarmsOnLine (FoL) – that resembles the one NESAAASA maintains for regional dairies: “Accurate information on rural properties is essential for a rapid response to a biosecurity outbreak or other natural event emergency. During the Waiheke Island operation [a FMD response in 2005], it took MAF over a week to identify and contact all properties with potentially at risk species. If the property information had been known for 90% rather than approximately 50% of properties, it would have taken only 2 days.” Combined Government and Industries FMD Preparedness Working Group (FMG), [Assessing New Zealand’s Preparedness for Incursions of Foot and Mouth Disease and Recommendations for Improvement](#) (October, 2011), p. 50.

²⁹ ISO 22000 Resource Center, [ISO 22000: Traceability in Food Supply Chains, Part V: Critical Tracking Events](#) (May 30, 2014); Neil Hammerschmidt, USDA [Update on Implementation of ADT](#) for the NIAA Annual Conference in Omaha, NE (April 2, 2014), slide 2; Innovation Center for U.S. Dairy, [Guidance for Dairy Product Enhanced Traceability: Voluntary Practices and Protocols for Strengthening the U.S. Dairy Supply Chain](#) (September 2013), p. 3.

³⁰ “Over the last decade, the general approaches to healthcare-associated infection (HAI) prevention have taken two conceptually different paths: (1) vertical approaches that aim to reduce colonization, infection, and transmission of specific pathogens, largely through use of active surveillance testing (AST) to identify carriers, followed by implementation of measures aimed at preventing transmission from carriers to other patients, and (2) horizontal approaches that aim to reduce the risk of infections due to a broad array of pathogens through implementation of standardized practices that do not depend on patient-specific conditions. . . . Although vertical and horizontal approaches are not mutually exclusive and are often intermixed, some experts believe that the horizontal approach under usual endemic situations may offer the best overall value given the diversity of microorganisms that can cause HAIs and the constrained resources available for infection prevention efforts.” Edward Septimus *et al.*, [Approaches for Preventing Healthcare-Associated Infections: Go Long or Go Wide?](#), *Infection Control and Hospital Epidemiology* 35:S2, “A Compendium of Strategies to Prevent Healthcare-Associated Infections in Acute care Hospitals: 2014 Updates” (September 2014), pp. 797. Note, however, that differences of opinion on this front (horizontal vs. vertical approaches to infection control) can be very strong. Citing the dangers of MRSA, for example, advocates of the vertical approach have gone so far as to charge their opponents with “nihilism.” See, for example, the exchange between Richard P. Wenzel and Michael B. Edmond, [Screening for MRSA: A Flawed Hospital Infection Control Intervention](#), *Infection Control and Hospital Epidemiology* 29 (November 2008), pp. 1012–1018; and Barry M. Farr and William R. Jarvis, [Why We Disagree With the Analysis of Wenzel *et al.*](#), *Infection Control and Hospital Epidemiology* 30: 5 (May 2009), pp. 497-499, and the reply from Wenzel and Edmond, pp. 499-500. See also: Richard P. Wenzel

-
- and Michael B. Edmond. [Infection Control: The Case for Horizontal Rather Than Vertical Interventional Programs](#), *International Journal of Infectious Diseases* 14:Supplement 4 (October, 2010), pp. S3–S5.
- ³¹ New England States Animal Agricultural Security Alliance (NESAASA), [New England Secure Milk Supply \(SMS\) Plan](#) (July 20, 2015).
- ³² Secure Milk Supply (SMS), [State/Regional SMS Partners](#) (2015); Charles Broaddus, [The Mid-Atlantic Secure Milk Supply Project](#), USAHA Presentation (2012); Manoel Tamassia, Craig Schultz, and David Smith, [Mid-Atlantic States Secure Milk Supply Project – Overview](#), Presentation to the Northeast USAHA, Portland, ME (May 12, 2014); Michael Payne, [California Leads the Way in Foot and Mouth Disease Preparedness](#), *California Dairy Quality Assurance Program* 7:1 (Summer, 2013), p. 1.
- ³³ Richard P. Horwitz, “Resources for SMS Priority” (December, 2014).
- ³⁴ Richard P. Horwitz, [Foot-and-Mouth Disease \(FMD\) as a Hazard for New England Dairies](#) (June 30, 2011) and [New England as a Jurisdiction for Supporting Continuity of Dairy Operations: A Reassessment](#) (December 30, 2013).
- ³⁵ Darrell W. Trampel *et al.*, [A Federal and State Transport Plan for Movement of Eggs and Egg Products from Commercial Egg Production Premises in a High-Pathogenicity Avian Influenza Control Area](#), *Journal of the American Veterinary Medical Association* 235:12 (December 15, 2009), pp. 1412-1419; USDA-APHIS, [Ready Reference Guide – Overview of the Secure Food Supply \(SFS\) Plans](#) (August 2013).; Iowa State University, Center for Food Security and Public Health (CFSPH), [Secure Food Supply Plans](#) (2015); James A. Roth, [Secure Food Supply Business Continuity Plans: Federal, State, Industry, and Academic Partnerships](#) (2013); USDA-APHIS, [Continuity of Business / Secure Food Supply Plans](#) (September 2, 2014).
- ³⁶ The latest data (2010-2015) from the six states and the USDA National Agricultural Statistics Service (NASS) suggest that the typical dairy farm in New England has 3-4 employees (including part-timers as well as the owner/manager) and that state offices of animal health have fewer than the equivalent of six full-time employees (FTEs). Most have fewer than four to cover hundreds of farms and many thousands of large and small livestock.
- ³⁷ Richard P. Horwitz, [Foot-and-Mouth Disease \(FMD\) as a Hazard for New England Dairies](#) (June 30, 2011) and [New England as a Jurisdiction for Supporting Continuity of Dairy Operations: A Reassessment](#) (December 30, 2013).
- ³⁸ Canadian Food Inspection Agency, [Laying the Foundation for Your Biosecurity Plan](#), *Biosecurity for Canadian Dairy Farms – Producer Planning Guide* (June 8, 2013), 2.1-2.
- ³⁹ According to the USDA-AMS, Northeast Marketing Area, Federal Order 1, September 2013, nearly all of the milk produced in New England was processed within the region. Together, the 5 largest plants handled 52% of all the milk produced on New England dairy farms, and the 10 largest plants handled 82% of the total. Richard P. Horwitz, [New England as a Jurisdiction for Supporting Continuity of Dairy Operations: A Reassessment](#) (NESAASA 2013), p. 20.
- ⁴⁰ See, for example: Production Animal Disease Risk Assessment Program (PADRAP), [A PADRAP Perspective on Transportation of Live Animals in the Breeding Herd](#), *PADRAP Newsletter* (July 2013). In state-of-the-art swine and poultry production, individual components and sites have certainly become more biosecure, but they may have also become collectively more vulnerable to its imperfections. See, for example: James F. Lowe *et al.*, [Role of Transportation in Spread of Porcine Epidemic Diarrhea Virus Infection, United States](#), *Emerging Infectious Disease* 21:5 (May, 2014), pp. 872-874; Spenser R. Wayne, [Assessment of the Demographics and Network Structure of Swine Populations in Relation to Regional Disease Transmission and Control](#), Ph.D. Dissertation in Veterinary Medicine, University of Minnesota (June, 2011); and Richard P. Horwitz, *Hog Ties: What Pigs Tell Us about America* (Minneapolis: University of Minnesota Press, 2002).
- ⁴¹ Canadian Food Inspection Agency, *Poultry Service Industry Biosecurity Guide*, Appendix 2: [Examples of Conceptual Farm Layouts](#) (August 20, 2014); Caroline Blaken, [Ins and Outs of Good Biosecurity](#), *The Pig Site* (February 11, 2008); Connor, Joseph *et al.* [Truck Wash Biosecurity Critical](#), *National Hog Farmer*

(December 12, 2014). This plant layout, which includes a drying facility, is recommended for a congregate sites (e.g., a pork processing plant).

- ⁴² In barely six months (2014-2015), an outbreak of Highly Pathogenic Avian Influenza (HPAI) led to the loss of about 40 million commercial turkeys and chickens in the Midwest. Agricultural economists figured that effective losses totaled well over \$1 billion. The federal taxpayers' share exceeded \$400 million and was rising fast. USDA-APHIS, [Avian Influenza, USDA Questions and Answers: Biology of Avian Influenza and Recent Outbreaks](#), and [Update on Avian Influenza Findings: Poultry Findings Confirmed by USDA's National Veterinary Services Laboratories](#) (May, 2015); John Newton and Todd Kuethe, [An Outbreak unlike Any Other: Perspective on the 2014-2015 Avian Influenza](#), *Farmdoc Daily* 5:85 (May 8, 2015); David Pitt, Associated Press, [Bird Flu Cost Nearly \\$1 Billion in Minnesota and Iowa](#), *Seattle Times* (May 18, 2015); AgWeb, [Cost to Fight Bird Flu Could Climb to \\$500 Million](#), *Farm Journal* (June 8, 2015). For an overview of AI experience, see: David A. Halvorson, [Prevention and Management of Avian Influenza Outbreaks: Experiences from the United States of America](#), *Revue Scientifique et Technique* (OIE, 2009) 28:1 (2009), pp. 359-369.
- ⁴³ This chart covers the first reported detection on December 19, 2014 through June 17, 2015. USDA-APHIS, [Avian Influenza Findings Confirmed by USDA's National Veterinary Services Laboratories](#) (July 8, 2015). See also: Stephanie Strom, with map source attributed to USDA, [Egg Farms Hit Hard as Bird Flu Affects Millions of Hens](#), *New York Times* (May 14, 2015), p. A1; and accompanying on-line images for the *New York Times* by Ryan Donnell, [A Crisis in the Heart of Egg Country](#) (May 15, 2015).
- ⁴⁴ See, for example: [PED-Positive Farm Samples in U.S. Total 8,898](#), *The Pig Site* (November 17, 2014); Robert Herriman, [Pig Virus Strikes Oahu Pig Farm](#), *Outbreak News Today* (November 21, 2014).
- ⁴⁵ USDA-APHIS-VS, [Swine Enteric Coronavirus Disease \(SECD\) Situation Report – Feb 5, 2015](#) (February 4, 2015), pp. 2, 7-8. See also USDA-APHIS, [Technical Note: Porcine Epidemic Diarrhea \(PED\) and Swine Enteric Coronavirus Diseases \(SECD\), Including Porcine Epidemic Diarrhea Virus \(PEDV\)](#) (February 13, 2015). Note that the current outbreak of PED in the U.S. probably began in April, 2013, but tracking of the disease was inconsistent prior to the [Federal Order: Reporting, Herd Monitoring and Management of Novel Swine Enteric Coronavirus Diseases](#) (June 5, 2014). So, the map reproduced here covers only the first 6 months of reporting under the Federal Order. During that period (June through December 2014), there were 2,387 new PEDV positives. In the prior year (April, 2013 to June, 2014) when there was certainly an undercount, there were 6,976 new positives. So, 9,000 is a conservative estimate of the cumulative total. Furthermore, the case definition distinguishes PEDV (which has developed more than one strain, since first isolated) from another coronavirus (PDCOV) that also broke in swine in 2014 (with similar, albeit milder effects) and from other, familiar sorts of transmissible gastroenteritis in swine, such as TGE. USDA-APHIS, [Novel Swine Enteric Coronavirus Disease \(SECD\) Case Definition](#) (June 5, 2014). See also: Dane Goede *et al.*, [Previous Infection of Sows with a “Mild” Strain of Porcine Epidemic Diarrhea Virus Confers Protection against Infection with a “Severe” Strain](#), *Veterinary Microbiology* 176:1-2 (March 23, 2015), pp. 161-164; Richard P. Horwitz, *Hog Ties: What Pigs Tell Us about America* (Minneapolis: University of Minnesota Press, 2002); and Spenser R. Wayne, [Assessment of the Demographics and Network Structure of Swine Populations in Relation to Regional Disease Transmission and Control](#), Ph.D. Dissertation in Veterinary Medicine, University of Minnesota (June, 2011); and Pork Network, [PEDV Resource Center](#) (2015).
- ⁴⁶ “Global trade of animal and animal products is increasing, reflecting increased consumer demand for livestock products and fish. Increased consumer demand is not the only driver for increased international trade, since there is also replacement of locally produced products by internationally produced items. . . . Increased trade also can lead to increased concentration and specialisation in production, as well as increased genetic homogeneity in animal species. This can have implications for disease spread in terms of vulnerable animal populations and production systems. . . . The World Trade Organization (WTO) is founded on the principle of free trade. However, this principle is not absolute, due to the disease risks related to unrestricted trade. The risks and benefits of food trade need to be balanced to account for potential risks to human and animal health, i.e. animal health transmission risks vs. access to larger high price markets and public health risks vs. food security. Risk analysis is an important tool to manage and quantify risks and benefits; it can also take into account economic assessments.” Sofia Boqvist, [Contagious Animal Diseases: The Science Behind Trade Policies and Standards](#), *Veterinary Journal*

202:1 (October, 2014), p. 7. Practically speaking: “It is often said that risk assessments are based on the best available science, but because accurate information is frequently missing for many transboundary diseases, even for the major diseases which have been studied for a considerable time, there is the opportunity to interpret what is available in a very risk-averse manner – the significance of the FMD virus carrier animal is a good example.” Paul Kitching *et al.*, “Transboundary Disease Management: The Theory and the Practice – The Science and the Politics,” *Transboundary and Emerging Diseases* 55:1 (June, 2008), pp. 1. Put more abstractly: “The analogies constructed between morality and health, the fear of excess and the importance of self-control are rearticulated in a medical discourse which represents the monster as biological retribution for social deviation.” Frank Dikötter, *Imperfect Conceptions: Medical Knowledge, Birth Defects, and Eugenics in China* (New York: Columbia University Press, 1998), p. 10. For a startlingly overt admission of the political pressure on the science of setting benchmarks for animal-disease response, see [The WTO Agreement on the Application of Sanitary and Phytosanitary Measures](#) (January 1, 1995) and [Guidelines to Further the Practical Implementation of Article 5.5](#) (July 18, 2000). See also: Dorothy W. Geale. *et al.* “A Review of OIE Country Status Recovery Using Vaccinate-to-Live Versus Vaccinate-to-Die Foot-and-Mouth Disease Response Policies II: Waiting Periods After Emergency Vaccination in FMD Free Countries,” *Transboundary and Emerging Diseases* (October, 2013), pp. 1-19; and Theodore J.D. Knight-Jones, and Jonathan Rushton. “The Economic Impacts of Foot And Mouth Disease – What Are They, How Big Are They and Where Do They Occur?” *Preventive Veterinary Medicine* 112:3-4 (November 1, 2013), pp. 161-173; Ted C. Schroeder *et al.*, [Economic Impact of Alternative FMD Emergency Vaccination Strategies in the Midwestern United States](#), *Journal of Agricultural and Applied Economics* (January, 2015), pp. 1-30.

⁴⁷ In previewing the latest update of the Food, Agriculture, and Veterinary (FAV) Incident Annex to the Regional Interagency Operations Plan, the Federal Emergency Management Agency (FEMA) begins with the planning assumption: “An FAV emergency will not result in a Stafford Act Declaration,” thereby ceding its highest authority to gain federal funding (up to 75%) of the cost of disaster response. The [Robert T. Stafford Disaster Relief and Emergency Assistance Act](#) (Public Law 93-288, April 2013). Presentation on FEMA Region VII Food, Agriculture, and Veterinary Annex (November 13, 2014), slide 18.

⁴⁸ For a broad-gauge example of this reasoning, see: David Quammen, *Spillover: Animal Infections and the Next Human Pandemic* (New York: W.W. Norton, 2012), pp. 511-519.

⁴⁹ John D Collins and Patrick G. Wall, [Food Safety and Animal Production Systems: Controlling Zoonoses at Farm Level](#), *Revue Scientifique et Technique* (OIE) 23:2 (2004), p. 685.

⁵⁰ “Farm to farm movement of infected livestock is the most effective means by which animal diseases such as Foot and Mouth Disease can be spread.” United Kingdom, Department for Environmental Food and Rural Affairs (DEFRA), [Biosecurity Guidance to Prevent the Spread of Animal Diseases](#) (July, 2003), p. 2. Even forty years ago, researchers noted the exaggeration of risks attributed to milk tankers. For example: “It would seem that the risk of milk lorries spreading FMD is certainly less than might have been previously thought.” Martin E. Hugh-Jones, [A Simulation Spatial Model of the Spread of Foot-and-Mouth Disease through the Primary Movement of Milk](#), *Journal of Hygiene* 77:1 (August, 1976), p. 7. More recently: “The most common method of spread of FMD virus is by contact between an infected and a susceptible animal.” Richard Paul Kitching, A. Marcus Hutber and Michael V. Thrusfield, “A Review of Foot-and-Mouth Disease with Special Consideration for the Clinical and Epidemiological Factors Relevant to Predictive Modelling of the Disease,” *Veterinary Journal* 169:2 (March, 2005), p. 298. See also: NESAASA, [Plan for Milk Movement During a FMD Outbreak](#) (August 1, 2014) and Richard P. Horwitz, [FMD as a Hazard for New England Dairies](#) (June 30, 2011) and [Exercise Follow-up: Policy toward Dairy Farms with Swine in the New England SMS Plan](#) (April 7, 2014).

⁵¹ It should be noted, however, that disinfection with chlorine has also been associated with health risks, including cancer. See, for example, David Sedlak, “The Chlorine Dilemma,” in *Water 4.0: The Past, Present, and Future of the World’s Most Vital Resource* (New Haven, CT: Yale University Press, 2014), pp. 90-111.

⁵² Even in the absence of specific benchmarks, authorities concluded that special zones (“Blue boxes”) of heightened biosecurity helped arrest contagion in the U.K. in 2001. Royal Society. [Royal Society Infectious Disease in Livestock Inquiry Follow-Up Review](#) (December, 2004), p. 11.

⁵³ Nick Honhold, Tony Taucher, and Nick Taylor, “The Involvement of Milk Tankers in the Spread of Foot and Mouth Disease in Cumbria, 2001,” The University of Reading (2004), Appendix 5 in [Detailed Investigation of the Methods and Characteristics of Spread of FMD in Specific Geographic Clusters and the Effects of Control Measures during the 2001 Epidemic](#), Final Project Report to DEFRA (2005); Nick Honhold, [The Impact of Farm Gate Biosecurity on the Transmission of FMD in UK in 2001](#), International Control of Foot-and-Mouth Disease: Tools, Trends and Perspectives, 2006 Session of the Research Group of the Standing Technical Committee of the European Commission for the Control of Foot-and-Mouth Disease (EuFMD), Paphos, Cyprus (October 16-20, 2006), Appendix 3, p. 32; Pam Hullinger, *Pilot Case-Control Study of Dairies Affected and Unaffected by Foot and Mouth Disease in the Solway Plain of Cumbria* (November 25, 2011); Andrew D. Paterson et al., “A Quantitative Insight Into ‘Biosecurity’: A Case-Control Study Investigating the Risk Factors Predisposing Cumbrian Dairy Farms to Foot and Mouth Disease,” *Proceedings of the Society for Veterinary Epidemiology and Preventive Medicine*, ed. M. V. Thrusfield and E.A. Goodall, from the meeting held at University of Warwick, England, March 28-30, 2003 (University of Glasgow, 2003), pp. 208-217. See also: Jorgen M., Westergaard, ed., *Report on the Eradication of Foot-and-Mouth Disease on the Islands of Funen and Zealand* (Copenhagen: Danish Veterinary Service, 1982); and Norihiko Muroga et al., [Risk Factors for the Transmission of Foot-and-Mouth Disease during the 2010 Outbreak in Japan: A Case-Control Study](#), *BMC Veterinary Research* 9:150 (July 24, 2013), pp. 1-9. Muroga et al. conclude (pp. 1, 8): “In 2010, foot-and-mouth disease (FMD) occurred for the first time in a decade in Japan. Movement or shipment of people and animals around infected farms was restricted; however these contingency measures proved insufficient to prevent FMD spread. . . . [Nevertheless,] “After the 2010 FMD epidemic in Japan, the government strengthened FMD control measures and animal rearing guidelines were altered. Additional control measures included compulsory disinfection of people and vehicles entering rearing areas of the farms and recording visits of people and vehicles. Our results indicate these enhancements are likely to be effective in preventing FMD introduction and spread.”

⁵⁴ From NESAASA data, February 2015, with 68% of all licensed dairy farms in New England surveyed. Note that these surveys were conducted on-site in the presence of state animal health officials or their representatives. The response “Not now, but possible” refers to a capability that was not present at the time of the survey but that both the farmer and the regulator agreed could be established within a day or two, if required, even without any additional assistance (e.g., the farmer would just have to relocate a pressure sprayer to which there is ready access).

⁵⁵ According to a recent USDA survey, most dairy farmers in the U.S. did not know much about highly contagious livestock diseases in 1991 and that knowledge as well as efforts to keep such disease off their farms actually declined over the next fifteen years. USDA-APHIS Veterinary Services, National Animal Health Monitoring System (NAHMS), [Dairy 2007: Biosecurity Practices on U.S. Dairy Operations, 1991-2007](#) (May 2010).

⁵⁶ According to the *Oxford English Dictionary* (2015), the word “disaster” has roots that are closer to astrology than modern science. It came into English from Romance languages (from Latin and Greek via Spanish, Portuguese, Italian and French) by way of an understanding that life chances were determined in the heavens. “Dis-aster” meant an unfortunate alignment of planets and stars (des = from; astre = star). “Disaster is etymologically a mishap due to a baleful stellar aspect.” Whitney, William Dwight. [The Life and Growth of Languages: An Outline of Linguistic Science](#) (London: Henry S. King and Co., 1875), p. 99.

⁵⁷ The role of “science” in legitimizing the latest “standards” and “best practices” in emergency management invites comparison with analogues in the recent history of other “applied” disciplines. For example, a “science-based,” medical model for psychiatry was largely accomplished through the adoption (with the support of its professional association, academic researchers, and the pharmaceutical industry) of a new Diagnostic and Statistical Manual (DSM-III) in 1974. “But, as critics at the time noted, it was difficult to understand why this manual should be regarded as a great *scientific* achievement. No scientific discoveries had led to this reconfiguring of psychiatric diagnoses. The biology of mental disorders remained unknown, and the authors of DSM-III even confessed that this was so. . . . DSM-III, wrote Theodore Blau, president of the American Psychological Association, was more of a ‘political position paper for the American Psychiatric Association than a scientifically-based classification system.’ None of that mattered, however. With the publication of DESM-III, psychiatry had publicly donned a white coat.”

Robert Whitaker, *Anatomy of an Epidemic: Magic Bullets, Psychiatric Drugs, and the Astonishing Rise of Mental Illness in America* (NY: Crown Publishers, 2010), p. 270.

- ⁵⁸ Two open-source, stochastic models are conventional in FMD research: the [North American Animal Disease Spread Model \(NAADSM\)](#) for simulating herd-to-herd contagion, and the [Within Herd \(WH\) prevalence model](#). See: Neil Harvey and Aaron Reeves, eds., [Model Description: North American Animal Disease Spread Model 3.1](#) (October 25, 2010); Aaron Reeves *et al.*, [User's Guide for North American Animal Disease Spread Model 4.0](#) (2012); Neil Harvey *et al.*, [The North American Animal Disease Spread Model: A Simulation Model to Assist Decision Making in Evaluating Animal Disease Incursions](#), *Preventive Veterinary Medicine* 82 (2007), pp. 176-197; Aaron Reeves, [User's Guide for WH: A Simulation Model of Within-Unit Disease Dynamics](#), Version 9.7 (2012); Aaron Reeves *et al.*, [Development of a Stochastic, Individual-Based Modeling Framework for Within-Unit Transmission of Highly Infectious Animal Diseases](#) (2012).
- ⁵⁹ For a discussion of such limitations and promising alternatives, see for example: Michael E. Gorman, Lekelia D. Jenkins, and Raina K. Plowright, [Human Interactions and Sustainability](#), in *Sustainability: Multi-Disciplinary Perspectives*, ed. Heriberto Cabezas and Urmila Diwekar (Oak Park, IL: Bentham Science Publishers, 2012), pp. 88-111; and Raina K. Plowright *et al.*, [Causal Inference in Disease Ecology: Investigating Ecological Drivers of Disease Emergence](#), *Frontiers in Ecology and the Environment* 6:8 (October, 2008), pp. 420-429.
- ⁶⁰ For an overview of this issue, see Roger A. Pielke, Jr., *The Honest Broker: Making Sense of Science in Policy and Politics* (New York: Cambridge University Press, 2007) and Kiana Moore and Heather Allen, [Continuity of Business Plans for Animal Disease Outbreaks: Using a Logic Model Approach to Protect Animal Health, Public Health, and Our Food Supply](#), *Agriculture* 3, (April 23, 2013), pp. 253-270. Examples of confirmation of these generalization in government promotion of farm biosecurity, see: Claire Heffernan *et al.*, "An Exploration of the Drivers to Bio-Security Collective Action among a Sample of UK Cattle and Sheep Farmers," *Preventive Veterinary Medicine*, 87:3-4 (November 17, 2008), pp. 358-372; Bala Hota, The Effect of Observation of Environmental Workers on Thoroughness and Outcome of Environmental Cleaning. *Program and Abstracts of the 43rd Interscience Conference on Antimicrobial Agents and Chemotherapy (ICAAC)* (Washington DC: American Society for Microbiology Press, 2003), p. 369.
- ⁶¹ Thomas A. Birkland, *Lessons of Disaster: Policy Change after Catastrophic Events* (Washington, DC: Georgetown University Press, 2006); and Claire B. Rubin, ed., *Emergency Management: The American Experience 1900-2010*, 2nd Ed. (Boca Raton, FL: CRC Press, 2012). Note, for example, a key-word search of more than 15,000 scientific publications on reportable diseases, 1912-2013, found that "investments have largely been proportionate to the perceptions of disease at the wildlife-livestock interface, rather than the actual costs associated with them," and "Temporal trends in publications on AI a bTB correlated strongly with media interest in and research funding for these diseases, highlighting the influence of specific disease events and sociopolitical-economic drivers of research in this area." Anke K. Wiethoelter *et al.*, [Global Trends in Infectious Diseases at the Wildlife-Livestock Interface](#), *Proceedings of the National Academy of Science Early Edition* (July 20, 2015), p. 3. See also: Peter J. May, *Recovering from Catastrophes: Federal Disaster Relief Policy and Politics* (Westport: Greenwood Press, 1985); Patrick S. Roberts, *Disasters and the American State: How Politicians, Bureaucrats, and the Public Prepare for the Unexpected* (New York: Cambridge University Press, 2013); Rutherford H. Platt, *Disasters and Democracy: The Politics of Extreme Natural Events* (Washington, DC: Island Press, 1999); and Thomas A. Birkland, *After Disaster: Agenda Setting, Public Policy, and Focusing Events* (Washington, DC: Georgetown University Press, 1997).
- ⁶² The swine industry took very much this approach in response to PRRS. See, for example: American Association of Swine Veterinarians (AASV), [Production Animal Disease Risk Assessment Program \(PADRAP\)](#); Boehringer Ingelheim, [PADRAP](#) (2015); and Derald J. Holtkamp *et al.*, [Identifying Questions in the American Association of Swine Veterinarian's PRRS Risk Assessment Survey That Are Important for Retrospectively Classifying Swine Herds According to Whether They Reported Clinical PRRS Outbreaks in the Previous 3 Years](#), *Preventive Veterinary Medicine* 106:1(Sep 1, 2012), pp. 42-52.
- ⁶³ See, for example: E. Hunt McCauley *et al.*, *A Study of Potential Economic Impact of Foot and Mouth Disease in the United States*. (St. Paul: University of Minnesota Press, 1979); Andrew D. James, and J.

Rushton, "[The Economics of Foot and Mouth Disease](#)," *Revue Scientifique et Technique* (OIE) 21:3 (December 2002), pp. 637-644; Philip L Paarlberg, John G. Lee, and Ann H. Seitzinger, "Potential Revenue Impact of an Outbreak of Foot-and-Mouth Disease in the United States," *Journal of American Veterinary Medical Association* 220:7 (April 1, 2002), pp. 988-992; Donald Thompson *et al.*, "Economic Costs of the Foot and Mouth Disease Outbreak in the United Kingdom in 2001," *Revue Scientifique et Technique* (OIE) 21:3 (December 2002), pp. 675–687; Amy D., Hagerman *et al.*, [Impact of Foot-and-Mouth Disease Management Alternatives in the California Dairy Industry](#) (Foreign Animal and Zoonotic Disease Defense (FAZD) Center, Texas A&M University, October 30, 2009); National Research Council, *Long-term Planning for Research and Diagnosis to Protect U.S. Agriculture from Foreign Animal Diseases and Ectoparasites* (Washington, DC: National Academy Press, 1983); and T.J. Knight-Jones and J. Rushton, [The Economic Impacts of Foot and Mouth Disease – What Are They, How Big Are They And Where Do They Occur?](#), *Preventive Veterinary Medicine* 112:3-4 (November 1, 2013), pp. 161–173. . See also: Richard P. Horwitz, *Hog Ties: What Pigs Tell Us about America* (Minneapolis: University of Minnesota Press, 2002).

⁶⁴ William McNeill argues that the history of response to emergencies, particularly to pathogenic virus in people, has contributed to "conservation of catastrophe" by failing to anticipate "the limits of medical and other dimensions of our human capacity to make things the way we want them, and, by skill, organization and knowledge, to insulate ourselves from local and frequent disasters. Every time we do this we change natural ecological relationships, at the cost of creating a new vulnerability to some larger disaster, which happens less frequently, but is sure to happen sooner or later when the artificial system, for whatever reason, breaks down. . . . This is not a reason for holding back and not trying to understand and remake natural balances; quite the contrary. But we should also realize the limits of our powers. It is worth keeping in mind that the more we drive infections to the margins of human experience, the wider we open a door for a new catastrophic infection." William H. McNeill, "Patterns of Disease Emergency in History," in *Emerging Viruses*, ed. Stephen S. Morse (NY: Oxford University Press, 1993), pp. 35-36. After surveying the literature on emerging viruses, the editor warns responders to be careful what they wish for: "Infectious diseases are not dead and never will be. And we will always be substituting one set of diseases or reactions with viruses for another, depending on the changed ecologic circumstance." Stephen S. Morse, "Afterword: A Personal Summary Presented as a Guide for Discussion," in *Emerging Viruses*, ed. Stephen S. Morse (NY: Oxford University Press, 1993), pp. 292. See also: William H McNeill., with comments by Charles P. Kindleberger, "Control and Catastrophe in Human Affairs," *Daedalus* 118:1 (Winter, 1989), pp. 1-15; Nicholas Johnson, *The Role of Animals in Emerging Viral Diseases* (San Diego, CA: Academic Press, 2014); and David Quammen, *Spillover: Animal Infections and the Next Human Pandemic* (New York: W.W. Norton, 2012), pp. 38-45.

⁶⁵ See, for example: United Kingdom, Health and Safety Executive (HSE), [Final Report on Potential Breaches of Biosecurity at the Pirbright Site 2007](#) (December 20, 2007); and Homeland Security Newswire, [Government Admits Accidents at Plum Island Biolab](#) (April 14, 2008). See also The CDC, [Section IV – Laboratory Biosafety Level Criteria](#), *Biosafety in Microbiological and Biomedical Laboratories* (BMBL) 5th Edition (December, 2009), pp. 30-59; and [Quick Learn Lesson: Recognizing the Biosafety Levels](#) (2015). A report to the U.S. Department of Homeland Security featured an estimate of the potential cost of an accidental release of FMD from a proposed Plum-Island-style facility in Kansas: "The results . . . indicate the total losses range from about 16 billion dollars to 140 billion dollars in damage." [National Bio- and Agri-Defense Facility \(NBAF\): Updated Site-Specific Biosafety and Biosecurity Mitigation Risk Assessment](#), Vol 2 (February, 2012), p. 570.

⁶⁶ Anthony D. Harris *et al.*, [The Use and Interpretation of Quasi-Experimental Studies in Infectious Diseases](#), *Clinical Infectious Diseases* 38:11 (2004), pp. 1586-1591.

⁶⁷ More relevant to controlling FMD outbreaks is the Reproduction Ratio (R): "The reproduction ratio (R) is the average number of secondary infections caused by one infectious individual if the population is completely susceptible. If vaccination decreases R to less than one, the epidemic will die out and only minor outbreaks are expected (however, some transmission is still expected to occur until the epidemic ends). If R remains higher than 1, there can be major outbreaks and the epidemic may continue to grow." Plainly, the reproduction rate between herds (Rh) is much more relevant to anticipating the course of an outbreak or controlling it than the MID or the reproduction ratio within herds (R0), but it is also much less

researched. See, for example, USDA, APHIS, [NAHEMS Guidelines: Vaccination For Contagious Diseases Appendix A: Foot-And-Mouth Disease](#) (April, 2011), pp. 7-9, 33.

⁶⁸ Thomas J. Hagenaars *et al.*, [Estimation of Foot and Mouth Disease Transmission Parameters, Using Outbreak Data and Transmission Experiments](#), *Revue Scientifique et Technique* (OIE) 30:2 (2011), p. 474; Aldo Dekker, [Biosecurity and FMD Transmission](#), *Veterinary Record* 168:5 (February 5, 2011), p. 126. See also: Nick Honhold *et al.*, [Control of Foot-and-Mouth Disease](#), *Veterinary Record* 168:20 (May, 2011), pp. 541-542; and Royal Society, [Royal Society Infectious Disease in Livestock Inquiry Follow-Up Review](#) (December, 2004), p. 11.

⁶⁹ See, for example: Wayne Einfeld, "Inactivation of Foot-and-Mouth Disease Virus on Various Contact Surfaces," in [Report on the 2007 Workshop on Decontamination, Cleanup, and Associated Issues for Sites Contaminated with Chemical, Biological, or Radiological Materials](#), produced by Sarah Dun of the Eastern Research Group for the U.S. Environmental Protection Agency and Department of Homeland Security (May, 2008), pp. 26-27.

⁷⁰ MID is usually expressed as "the 50% infective dose" (ID₅₀, referring to the dilution of pathogen – the weight or volume per gram or ml – that infects 50% of the hosts, i.e., the ratio of infected to survivor or uninfected cell cultures) or "the number of plaque forming units" (PFU/ml or PFU/g, referring to dilutions which produce countable, individual plaques). Soren Alexandersen *et al.*, "The Pathogenesis and Diagnosis of Foot-and-Mouth Disease," *Journal of Comparative Pathology* 129:1 (July, 2003), pp. 1-36. See also: Paul Suttmoller and David J. Vose, [Contamination of Animal Products: The Minimum Pathogen Dose Required to Initiate Infection](#), *Revue Scientifique et Technique* (OIE) 16:1 (1997), pp. 30-32.

⁷¹ See, for example: Margo E. Chase-Topping *et al.*, [Understanding Foot-and-Mouth Disease Virus Transmission Biology: Identification of the Indicators of Infectiousness](#), *Veterinary Research* 44:6 (July 3, 2013), pp. 1-10, though important variation is observed by Karin Orsel *et al.* in [Different Infection Parameters between Dairy Cows and Calves after an Infection with Foot-and-Mouth Disease Virus](#), *Veterinary Journal* 186:1 (October, 2010), pp. 116-118. The message for dairies, however, remains fearsome: "In the groups of calves, mild clinical signs, without disturbance to the health of the calves, were observed and not all contact-exposed calves became infected or shed virus or became positive for FMDV antibodies. Dairy cows, however, developed severe clinical signs (salivation, loss of appetite, lameness, mastitis) and all contact-exposed cows became FMDV infected. . . . Our studies illustrate that not only the clinical manifestation of an FMDV infection differed between adult and young cattle, but that cows and calves also differed in the amount of excreted virus. These differences did not however result in a significant difference in virus transmission, which could be due to limited power of the experiments."

⁷² For example: "For FMD virus (FMDV) contained in an animal product, such as meat or milk, to be 'infectious', a virus unit must be in the right place at the right time. . . . The same amount of virus may only occasionally come into contact with a susceptible cell when administered by a different route. The feeding of contaminated material is about 4-5 orders of magnitude less efficient at starting 'infection' than the IDL inoculation [intradermal tongue injection, a common mode of experimental infection]." Paul Suttmoller and David J. Vose, [Contamination of Animal Products: The Minimum Pathogen Dose Required to Initiate Infection](#), *Revue Scientifique et Technique* (OIE) 16:1 (1997), p. 30.

⁷³ Sara W. McReynolds *et al.*, [Modeling the Impact of Vaccination Control Strategies of a Foot and Mouth Disease Outbreak in the Central United States](#), *Preventive Veterinary Medicine* 117:3-4 (December, 2014), pp. 487-504.

⁷⁴ "The uncertainty inherent in many catastrophic disasters should humble those who claim to be prepared. For most events serious enough to be called disasters, we observe the effects of a generator of probability, not the generator itself. In a game of chance, we know that a die has six sides, but for some events such as a severe disaster we may observe historical data that show a world that appears to have a six sided die until one day it is suddenly governed by a sixteen-sided die. The upshot of this reality is that risk models or memory of the recent past convey a false sense of certainty. The inherent uncertainty involved in preparing for the worst contrasts with politicians' and bureaucrats increasingly bold promises to protect citizens from all hazards. . . . A central claim here is that by the late twentieth century, entrepreneurial bureaucrats were claiming credit for successes that their agencies did not deserve and being blamed for failures beyond their control." Patrick S. Roberts, *Disasters and the American State: How Politicians,*

Bureaucrats, and the Public Prepare for the Unexpected (New York: Cambridge University Press, 2013), pp. 177, 188.

⁷⁵ Such priorities can also be found in standard advice about controlling infection in human facilities. See, for example: The Centers for Disease Control and Prevention (CDC), [School Guide: How to Clean and Disinfect Schools to Help Slow the Spread of Flu](#) (October, 2010).

⁷⁶ Even successful efforts to control outbreaks suggest humbling lesson. In the case of the 2003 outbreak of HPAI H7N7 in the Netherlands: “Unfortunately, it was not possible to establish the contribution of individual [biosecurity] measures to the overall reduction of virus transmission. Although the control measures were effective in reducing transmission, the estimates of the reproduction ratio were still >1 . This suggests that the control measures were probably not sufficient to halt the epidemic. In fact, containment of the epidemic may have been due to the depletion of susceptible flocks as a result of culling rather than to a decrease in the transmission rate. Therefore, the main value of the control measures may be in preventing the spread of virus to unaffected areas rather than in preventing the spread of virus within an area. This may be especially significant for areas with a high flock density . . . where an epidemic may be impossible to stop once it has taken off. This is in line with the findings in 1999 in Italy, where an outbreak of HPAI H7N1 virus spread quickly and extensively and could be controlled only by the depopulation of nearly all flocks in the affected area of 5500 km². . . . Our results indicate that outbreaks of HPAI viruses are difficult – if not impossible – to control with usual measures in poultry-dense areas, and effective control could be achieved only by depopulation of the whole affected area. Moreover, new outbreaks can be expected, because AI virus strains are endemic in the wild waterfowl population. It might be worthwhile to consider reducing the flock density of commercial flocks, to reduce the probability of another epidemic of this size, or to consider vaccinating poultry, as an additional control measure.” Arjan Stegeman *et al.*, [Avian Influenza A Virus \(H7N7\) Epidemic in the Netherlands in 2003: Course of the Epidemic and Effectiveness of Control Measures](#), *Journal of Infectious Disease* 190:12 (December 15, 2004), p. 2094.

⁷⁷ An influential, widely cited study found some encouraging evidence of the effectiveness of efforts to contain the 2001 FMD outbreak in the U.K. – a reduction in the case-reproduction ration from 3.3 to 1.1 – as “control” measures were implemented, but “controls” in this case refers, not to biosecurity, but to culling livestock on infected farms within 24 hours of the disease being reported and those on neighboring farms within 48 hours. Mark E.J. Woolhouse *et al.*, [Epidemiology: Foot-and-Mouth Disease under Control in the UK](#), *Nature* 411:6835 (May 17, 2001), pp. 258-259.

⁷⁸ Dale Polson uses a similar line of reasoning (from human to animal healthcare, in this case, a [Harvard Disease Risk Index](#)) in his [Overview of PRRS Risk Assessment](#) for PADRAP Training at the AASV Annual Meeting in San Diego, CA (March 2, 2013).

⁷⁹ William A. Rutala, [‘Best’ Practices for Surface Disinfection](#), Association for Professionals in Infection Control and Epidemiology (APIC) Webinar (April 30, 2012). Rutala is Director of Hospital Epidemiology for University of North Carolina Health Care, and Director of the N.C. Statewide Program for Infection Control as well as a member of the FIFRA Scientific Advisory Panel on Antimicrobial Research Strategy for Disinfectants in the U.S. Environmental Protection Agency and a member of the editorial board of the journal, *Infection Control and Hospital Epidemiology*. See also: William A. Rutala. *et al.*, [Guideline for Disinfection and Sterilization in Healthcare Facilities, 2008](#) (Atlanta: Centers for Disease Control and Prevention, 2008).

⁸⁰ “While resistance to biocides is generally not judged to be as critical as antibiotic resistance, scientific data support the need for proper use, i.e. avoidance of widespread application, especially in low concentrations and in consumer products. The decontamination ability of the substances used; prevention of resistance; and safety for patients, personnel and the environment are the cornerstones that interact with each other. Future work should focus on this complex background.” Marcus Dettenkofera and Robert C. Spencer, “Importance of Environmental Decontamination a Critical View,” *Journal of Hospital Infection* 65:Supplement 2 (June, 2007), p. 55.

⁸¹ A special issue of *Infection Control and Hospital Epidemiology* 34:5 (May, 2013) on [The Role of the Environment in Infection Prevention](#) pivots on wisdom that is equally conventional in human and veterinary

medicine: normal, everyday movement can spread pathogens borne on environmental surfaces from one occupant to another.

- ⁸² Note that this generalization likely also holds not only for farms but also for veterinary hospitals. They are more at-risk than human facilities because “veterinary patients frequently pass body fluids onto environmental surfaces,” because equipment is more likely to be shared, and because patients are not separated by private rooms or distanced from the floor by a bed. Joshua A. Portner and Justine A. Johnson, [Guidelines for Reducing Pathogens In Veterinary Hospitals: Disinfectant Selection, Cleaning, Protocols, and Hand Hygiene](#),” *Compendium: Continuing Education for Veterinarians* (May 2010), p. E6.
- ⁸³ For on-line evidence of attention to HAI in the named agencies, see: [American Hospital Association](#) (AHA), [Association for Professionals in Infection Control and Epidemiology](#) (APIC), [Centers for Disease Control and Prevention](#) (CDC) [Healthcare Infection Control Practices Advisory Committee](#) (HICPAC), [Infectious Diseases Society of America](#) (IDSA), U.S. Department of Health and Human Services [Office of Disease Prevention and Health Promotion](#) (ODPHP), [Society for Healthcare Epidemiology of America](#) (SHEA), [Society of Hospital Medicine](#) (SHM), and [The Joint Commission](#) (2015). See, for example: Joint Commission, *Infection Protection and Control Issues in the Environment of Care*, ed. Ilese J Chatman (Oakbrook Terrace, IL: Joint Commission Resources, 2009); Joint Commission, *Environment of Care Essentials for Health Care*, ed. Kristine M. Miller (Oakbrook Terrace, IL: Joint Commission Resources, 2014); and Joint Commission, *The APIC/JCR Infection Prevention and Control Workbook*, 2nd Edition, ed. Kathleen Meehan Arias and Barbara Moore Soule (Oakbrook Terrace, IL: Joint Commission Resources, 2010).
- ⁸⁴ “Our survey results indicate that on any given day approximately 1 of every 25 inpatients in U.S. acute care hospitals has at least one healthcare-associated infection. Pneumonia and surgical-site infection were the most common infection types, and *C. difficile* was the most common pathogen. Infections other than those associated with central catheters, urinary catheters, and ventilators account for the majority of the U.S. burden of healthcare-associated infections and may warrant increased attention.” Shelley S. Magill *et al.*, [Multistate Point-Prevalence Survey of Health Care–Associated Infections](#) *New England Journal of Medicine* 370:13 (March 27, 2014), p. 1197. These estimates from 2011 data, though disturbing, are considerably lower than those from 2007: “Healthcare-associated infection (HAI) prevention is the quintessential patient safety issue. HAIs are the fifth leading cause of death in acute care hospitals. [According to Klevens *et al.* in 2007] Up to 15% of patients develop an infection while hospitalized. In the United States, this accounts for approximately 1.7 million HAIs and 99,000 deaths annually. A recent report [Zimlichman *et al.*, 2013] estimated US healthcare system costs attributable to the five most common HAIs (central line-associated bloodstream infections [CLABSI], catheter-associated urinary tract infections [CAUTI], ventilator-associated pneumonia [VAP], surgical site infection [SSI], and *Clostridium difficile* infection [CDI]) to be \$9.8 billion, even without considering the sizable societal costs.” Edward Septimus *et al.*, [Commentary: Maintaining the Momentum of Change: The Role of the 2014 Updates to the Compendium in Preventing Healthcare-Associated Infections](#), *Infection Control* 35:5 (May, 2014), p. 460. Even earlier in the 2000s, but still on-line in 2015: “HAIs affect 5 to 10 percent of hospitalized patients in the U.S. per year. Approximately 1.7 million HAIs occur in U.S. hospitals each year, resulting in 99,000 deaths and an estimated \$20 billion in healthcare costs.” The Centers for Disease Control and Prevention (CDC), [CDC at Work: Preventing Healthcare-Associated Infections](#) (2015). The CDC posts progress reports on-line, [NHSN National HAI Reports](#) (January 13, 2015). The latest is: [National and State Healthcare Associated Infections Progress Report](#) (January, 2015).
- ⁸⁵ Carl Zimmer emphasizes the danger in trying to separate healthy organisms, including humans, from viruses, even as contact also includes its dangerous. “Endogenous retroviruses may be dangerous parasites, but scientists have discovered a few that we have commandeered for our own benefit. When a fertilized egg develops into a fetus, for example, some of its cells develop into the placenta, an organ that draws in nutrients from the mother’s tissues. The cells in the outer layer of the placenta fuse together, sharing their DNA and other molecules. . . . Researchers have found that a human endogenous retrovirus gene plays a crucial role in that fusion. The cells in the outer placenta use the gene to produce a protein on their surface, which latches them to neighboring cells. In our most intimate moment, as new human life emerges from old, viruses are essential to our survival. There is no us and them – just a gradually blending and shifting mix of DNA Viruses and other organisms form a continuum. We humans are an inextricable blend of mammal and virus. Remove our virus-derived genes, and we would be unable

to reproduce. We would probably all quickly fall victim to infections from other viruses. Some of the oxygen we breathe is produced through a mingling of viruses and bacteria in the oceans. That mixture is not a fixed combination, but an ever-changing flux. The oceans are a living matrix of genes shuttling among hosts and viruses.” Carl Zimmer, *A Planet of Viruses* (Chicago: Chicago University Press, 2011), p. 93.

⁸⁶ Centers for Medicare and Medicaid Services (CMS), [Fact sheets: CMS to Improve Quality of Care during Hospital Inpatient Stays](#) (August 4, 2014) and [Fact sheets: CMS Finalizes Program Changes for Medicare Advantage and Prescription Drug Benefit Programs for Contract Year 2016](#) (February 6, 2015). See also: United States, Department of Health and Human Services (DHHS), Agency for Healthcare Research and Quality (AHRQ), [Health Care-Associated Infections](#) (October, 2012); Patrick Conway, [U.S. Efforts To Reduce Healthcare-Associated Infections](#), Testimony by the Chief Medical Officer and Director of the Office of Clinical Standards and Quality, Centers for Medicare and Medicaid Services, U.S. Department of Health and Human Services (HHS), before the Committee on Health, Education, Labor and Pensions, United States Senate (September 24, 2013); and Huan J. Chang and William R. Jarvis, “Epidemiology and Control of Infectious Diseases in Health Care Facilities,” in *Clinical Infectious Diseases: A Practical Approach*, ed. Richard K. Root (New York, Oxford University Press, 1999), pp. 61-70; Stephanie J. Dancer, [Mopping up Hospital Infection](#), *Journal of Hospital Infection* 43:2 (November, 1999), pp. 85-100; Betsy McCaughey, [Unnecessary Deaths: The Human and Financial Costs of Hospital Infections](#), 2nd Edition (Committee to Reduce Infection Deaths, 2006); R. Monina Klevens *et al.*, [Estimating Health Care-Associated Infections and Deaths in U.S. Hospitals, 2002](#), *Public Health Reports* 122 (March-April, 2007), pp. 160-166.

⁸⁷ See, for example, University of Minnesota, Center for Animal Health and Food Safety and USDA-APHIS-VS-CEAH, [Secure Milk Supply \(SMS\) Plan for a Foot-and-Mouth Disease \(FMD\) Outbreak: Baseline Risk Assessment for the Movement of Raw Milk to Processing Results Summary](#) (September, 2012), and [Risk Assessment for the Transport of Raw Milk Into, Within, and Out of a Control Area during a Foot and Mouth Disease Outbreak](#) (March 6, 2015). This risk assessment was developed for the SMS Project to guide the development of continuity-of-operation strategy, but the SMS Performance Standards (recommended remediation measures) were developed in a parallel, simultaneous process that was essentially complete before the risk assessment was fully drafted, peer reviewed, or released.

⁸⁸ “Each infection prevention recommendation was assigned a grading of evidence rating (low, moderate, or high level of evidence) adapted from criteria utilized by the Grades of Recommendation, Assessment, Development, and Evaluation (GRADE) system and the Canadian Task Force on Preventive Health Care. Recommendations are categorized as either (1) basic practices that should be adopted by all acute care hospitals or (2) special approaches that can be considered for use in locations and/or populations within hospitals when HAIs are not controlled after full implementation of basic practices.” Deborah S. Yokoe *et al.*, [Introduction to ‘A Compendium of Strategies to Prevent Healthcare-Associated Infections in Acute Care Hospitals: 2014 Updates’ SHEA/IDSA Practice Recommendation](#), *Infection Control* 35:5 (May, 2014), pp. 456-459.

⁸⁹ Deborah S. Yokoe, *et al.*, [Introduction to ‘A Compendium of Strategies to Prevent Healthcare-Associated Infections in Acute Care Hospitals: 2014 Updates’ SHEA/IDSA Practice Recommendation](#), *Infection Control* 35:5 (May 2014), p. 456; U.S. Preventive Service Task Force (USPTS), [Grade Definitions](#) (October, 2014); Abdur Rahman Khan *et al.*, [Quality and Strength of Evidence of the Infectious Diseases Society of America Clinical Practice Guidelines](#), *Clinical Infectious Diseases* 51:10 (November 15, 2010), p. 1148.

⁹⁰ Gordon H. Guyatt *et al.*, [Going from Evidence to Recommendations](#), *BMJ* 336:7652 (May 10, 2008), pp. 1049-1051; Gordon H. Guyatt *et al.*, [GRADE: An Emerging Consensus on Rating Quality of Evidence and Strength of Recommendations](#), *BMJ* 336:7650 (April 26, 2008), pp. 924-926; Holger J. Schünemann, [Brief Summary of the GRADE Framework](#), Presentation at the 2011 Annual Conference Agency for Healthcare Research and Quality (Washington, DC: AHRQ, September 20, 2011); Holger J. Schünemann and Nancy Berkman, [Facing Challenging Situations When Grading Strength of Evidence](#), Agency for Healthcare Research and Quality (AHRQ) 2011 Annual Conference, Bethesda, MD (September 20, 2011); Holger J. Schünemann and Nancy Santesso, [An Overview Summary](#), *The GRADE Approach – On-line Learning Modules for Guideline Development at WHO* (World Health Organization,

November, 2011); Holger J. Schünemann and Nancy Santesso, [Formulating Questions and Choosing Patient Important Outcomes](#), *The GRADE Approach – On-line Learning Modules for Guideline Development at WHO* (World Health Organization, November, 2011); Holger J. Schünemann *et al.*, [Grading Quality of Evidence and Strength of Recommendations for Diagnostic Tests and Strategies](#), *BMJ* 336:7653 (May 17, 2008), pp.1106-1110; Holger J. Schünemann, Faruque Ahmed, and Rebecca Morgan, [Guideline Development Using GRADE](#) (WHO, September 9, 2011); Canadian Task Force on Preventive Health (CTFPHC), GRADE Working Group, [Grades of Recommendation, Assessment, Development, and Evaluation](#) (2011).

⁹¹ “Judgments are thus needed to assess the directness of test results in relation to consequences of diagnostic recommendations that are important to patients.” Holger J. Schünemann *et al.*, [Grading Quality of Evidence and Strength of Recommendations for Diagnostic Tests and Strategies](#), *BMJ* 336:7653 (May 17, 2008), p. 1107.

⁹² Holger J. Schünemann, and Nancy Santesso, [An Overview Summary](#), *The GRADE Approach – On-line Learning Modules for Guideline Development at WHO* (World Health Organization, November, 2011), slide 17. PICO is an acronym for key considerations in deciding whether a practice merits GRADEing: Population, Intervention, Comparison, Outcomes. Gordon H. Guyatt *et al.*, [What is “Quality of Evidence” and Why Is It Important to Clinicians?](#) *BMJ* 336:7651 (May 3, 2008), pp. 995-998.

⁹³ CDC HICPAC, [Updating the Guideline Methodology of the Healthcare Infection Control Practices Advisory Committee \(HICPAC\)](#) (December 29, 2009), Table 3.

⁹⁴ Holger J. Schünemann reprinted the cartoon by Leo Garel on “Belief and Confidence: A Two-Dimensional Weather Report” by permission of the *Wall Street Journal* in [Brief Summary of the GRADE Framework](#), Presentation at the 2011 Annual Conference Agency for Healthcare Research and Quality (Washington, DC: AHRQ, September 20, 2011), slide 9; Holger J. Schünemann and Nancy Santesso, [Formulating Questions and Choosing Patient Important Outcomes](#), *The GRADE Approach – On-line Learning Modules for Guideline Development at WHO* (World Health Organization, November, 2011), slides 19 and 30.

⁹⁵ See, for example: John M. Boyce, “Environmental Contamination Makes An Important Contribution To Hospital Infection,” *Journal of Hospital Infection* 65:Supplement 2, (June 2007), pp. 50-54; Stephanie J Dancer, [Controlling Hospital-Acquired Infection: Focus on the Role of the Environment and New Technologies for Decontamination](#), *Clinical Microbiology Reviews* 27:4 (October, 2014), pp. 665-690.

⁹⁶ Stephen C. Hines, “Strengthening National Efforts to Reduce Healthcare-Associated Infection,” in [Advances in the Prevention and Control of HAIs](#), ed. James B. Battles *et al.*, prepared for the U.S. Department of Health and Human Services (DHHS), Agency for Healthcare Research and Quality (June, 2014), pp. 23-24. For example: “During the past 20 years, many published reports have described improved outcomes as the result of modifications in basic environmental cleaning. Unfortunately, causal analysis of essentially all of these studies has been greatly hampered by the simultaneous implementation of multiple interventions along with ‘improved cleaning.’ This issue is particularly well illustrated by the reports of interventions to minimize healthcare-onset *Clostridium difficile* infection beginning in the mid-1980s. Although more than 20 quasi-experimental, often-outbreak-associated studies have supported the likely effect of improved environmental hygiene on *C. difficile* transmission, all of these studies consist of several interventions implemented simultaneously. . . . It is possible that the novelty of a new cleaning agent results in better attention to process and increased thoroughness of cleaning that is behavioral in origin, due to the heightened attention surrounding change. This phenomenon has been suggested in other infection prevention activities. To date, none of the clinical studies designed to assess specific disinfectant chemistries – particularly bleach – or application systems such as microfiber have controlled for this phenomenon by monitoring the thoroughness of general cleaning processes in addition to microbiological outcomes. This will be important in future studies.” Philip C. Carling and Susan S. Huang, [Improving Healthcare Environmental Cleaning and Disinfection: Current and Evolving Issues](#), *Infection Control and Hospital Epidemiology* 34:5, Special Topic Issue: The Role of the Environment in Infection Prevention (May 2013), pp. 508.

⁹⁷ Earle H. Spaulding, Chemical Disinfection and Antisepsis in the Hospital, *Journal of Hospital Research* 9:1 (1972) pp. 5–31; Emily R. M. Sydnor and Trish M. Perl, [Hospital Epidemiology and Infection Control](#)

[in Acute-Care Settings](#), *Clinical Microbiology Reviews* 24:1 (January, 2011), pp. 141-173; The Centers for Disease Control and Prevention (CDC), [Guideline for Disinfection and Sterilization in Healthcare Facilities, 2008](#), ed. William A Rutala, *et al.* (2008), p. 65.

⁹⁸ Certification Board for Sterile Processing and Distribution (CBSPD), [Inconsistency in the Decontamination Process](#) (2015).

⁹⁹ The Centers for Disease Control and Prevention (CDC), Healthcare Infection Control Practices Advisory Committee (HICPAC), *Morbidity and Mortality Weekly Report* (MMWR), Appendix A: [Regulatory Framework for Disinfectants and Sterilants](#), Recommendations and Reports 52:RR17 (December 19, 2003), p. 63; The Centers for Disease Control and Prevention (CDC), [Appendix B – Decontamination and Disinfection](#), *Biosafety in Microbiological and Biomedical Laboratories* (BMBL) 5th Edition (December, 2009), pp. 326-335.

¹⁰⁰ Centers for Disease Control and Prevention (CDC), [Guideline for Disinfection and Sterilization in Healthcare Facilities, 2008](#), ed. William A Rutala *et al.* (2008), p. 10.

¹⁰¹ “Although the environment serves as a reservoir for a variety of microorganisms, it is rarely implicated in disease transmission except in the immunocompromised population. . . . Although microbiologically contaminated surfaces can serve as reservoirs of potential pathogens, these surfaces generally are not directly associated with transmission of infections to either staff or patients. The transferal of microorganisms from environmental surfaces to patients is largely via hand contact with the surface. Although hand hygiene is important to minimize the impact of this transfer, cleaning and disinfecting environmental surfaces as appropriate is fundamental in reducing their potential contribution to the incidence of healthcare-associated infections.” The Centers for Disease Control and Prevention (CDC), Healthcare Infection Control Practices Advisory Committee (HICPAC), [Guidelines for Environmental Infection Control in Health-Care Facilities: Recommendations of CDC and the Healthcare Infection Control Practices Advisory Committee \(HICPAC\)](#) (2003), p. 71. Note that the CDC-endorsed treatments of environmental surfaces for “prevention of infection” and for “control of infection” are the same. The consistency makes sense, given their recommendation: “Assume that every person is potentially infected or colonized with an organism that could be transmitted in the healthcare setting and apply the following infection control practices during the delivery of health care.” The Centers for Disease Control and Prevention (CDC), Healthcare Infection Control Practices Advisory Committee (HICPAC), [Guideline for Isolation Precautions: Preventing Transmission of Infectious Agents in Healthcare Settings](#) (2007), p. 77, with elaboration on pp. 71-90. See also: Gerald McDonnell and Peter Burke, [Disinfection: Is it Time to Reconsider Spaulding?](#), *Journal of Hospital Infection* 78:3 (July, 2011), pp. 163-170; The Centers for Disease Control and Prevention (CDC), [Guideline for Disinfection and Sterilization in Healthcare Facilities, 2008](#), ed. William A Rutala *et al.* (2008), p. 65; Jürgen Gebel, Stefanie Gemein, and Martin Exner, “Surface Cleaning and Disinfection: Insight into the Situation in Germany and Europe,” *Healthcare Infection* 18 (2013), pp. 31-36.

¹⁰² Note that this estimation of the value of redundancy holds only insofar as the two measures are independent and potentially 100% effective on their own. Nick Honhold, [The Impact of Farm Gate Biosecurity on the Transmission of FMD in UK in 2001](#), International Control of Foot-and-Mouth Disease: Tools, Trends and Perspectives, 2006 Session of the Research Group of the Standing Technical Committee of the European Commission for the Control of Foot-and-Mouth Disease (EuFMD), Paphos, Cyprus (October 16-20, 2006), Appendix 3, pp. 32-33.

¹⁰³ See, for example: S.J. Smith *et al.*, [Where do Hands Go? An Audit of Sequential Hand-Touch Events on a Hospital Ward](#), *Journal of Hospital Infection* 80:3 (March, 2012), pp. 206-211; Stephanie J. Dancer, [The Role of Environmental Cleaning in the Control of Hospital-Acquired Infection](#), *The Journal of Hospital Infection* 73:4 (December, 2009), pp. 378-85; The Centers for Disease Control and Prevention (CDC), Healthcare Infection Control Practices Advisory Committee (HICPAC), [Guideline for Isolation Precautions: Preventing Transmission of Infectious Agents in Healthcare Settings](#) (2007), pp. 60, 81-82.

¹⁰⁴ See, for example: Stephanie J. Dancer, [Hospital Cleaning in the 21st Century](#), *European Journal of Clinical Microbiology and Infectious Disease* 30:12 (December, 2011), pp. 1473-1481.

¹⁰⁵ Philip C. Carling, [Towards Eliminating Clostridium difficile Infections \(CDI\) in Illinois](#), presentation to the Illinois Campaign to Eliminate Clostridium difficile (July, 2012), slides 22 and 18.

- ¹⁰⁶ Even proponents of more aggressive measures to combat environmental contamination admit: “There is no standard method for measuring actual cleanliness of surfaces or the achievement of certain cleaning parameters (e.g., adequate contact time of disinfectant) or for defining the level of microbial contamination that correlates with good or poor environmental hygienic practices.” Alice Guh, Philip Carling, and the CDC Environmental Evaluation Workgroup, [Options for Evaluating Environmental Cleaning](#) (December, 2010). Note that, while Guh works for the CDC, Carling “owns a patent for the fluorescent targeting evaluation system described in this document.” See also: The Centers for Disease Control and Prevention (CDC), [National Action Plan to Prevent Health Care-Associated Infections: Road Map to Elimination](#) (September 23, 2014), and [National and State Healthcare Associated Infections Progress Report](#) (March, 2014), p. 4; William A. Rutala, [‘Best’ Practices for Surface Disinfection](#), Association for Professionals in Infection Control and Epidemiology (APIC) Webinar (April 30, 2012).
- ¹⁰⁷ The CDC “Standard Precautions for ‘Care of the Environment’” include Item IV.F.2: “Clean and disinfect surfaces that are likely to be contaminated with pathogens, including those that are in close proximity to the patient (e.g., bed rails, over bed tables) and frequently-touched surfaces in the patient care environment (e.g., door knobs, surfaces in and surrounding toilets in patients’ rooms) on a more frequent schedule compared to that for other surfaces (e.g., horizontal surfaces in waiting rooms). (Category IB).” Note the inclusion here of a confidence level indicating “low quality of evidence” for the recommendation. The Centers for Disease Control and Prevention (CDC), Healthcare Infection Control Practices Advisory Committee (HICPAC), [Guideline for Isolation Precautions: Preventing Transmission of Infectious Agents in Healthcare Settings](#) (2007), pp. 81-82. See also The Centers for Disease Control and Prevention (CDC), Healthcare Infection Control Practices Advisory Committee (HICPAC), [Guidelines for Environmental Infection Control in Health-Care Facilities: Recommendations of CDC and the Healthcare Infection Control Practices Advisory Committee \(HICPAC\)](#) (2003), p. 75; Centers for Disease Control and Prevention (CDC), [School Guide: How to Clean and Disinfect Schools to Help Slow the Spread of Flu](#) (October, 2010); Marcus Dettenkofera and Robert C. Spencer, “Importance of Environmental Decontamination: A Critical View,” *Journal of Hospital Infection* 65:Supplement 2 (June, 2007), pp. 55-57; Jürgen Gebel, Stefanie Gemein, and Martin Exner, “Surface Cleaning and Disinfection: Insight into the Situation in Germany and Europe,” *Healthcare Infection* 18 (2013), pp. 31-36; Kirk Huslage *et al.*, “Microbial Assessment of High-, Medium-, and Low-Touch Hospital Room Surfaces,” *Infection Control and Hospital Epidemiology* 34:2 (February 2013), pp. 211-212; William A. Rutala, [‘Best’ Practices for Surface Disinfection](#), Association for Professionals in Infection Control and Epidemiology (APIC) Webinar (April 30, 2012); William A. Rutala and David J. Weber. [Disinfection and Sterilization in Health Care Facilities: What Clinicians Need to Know](#), *Clinical Infectious Diseases* 39:5 (September 1, 2004), p. 705.
- ¹⁰⁸ David J. Weber and William A. Rutala, [Understanding and Preventing Transmission of Healthcare-Associated Pathogens Due to the Contaminated Hospital Environment](#), *Infection Control and Hospital Epidemiology* 34:5, Special Topic Issue: The Role of the Environment in Infection Prevention (May, 2013), p. 449. See also: David J. Weber and William A. Rutala, “Environmental Issues and Nosocomial Infections,” in *Prevention and Control of Nosocomial Infections*, ed. R.P. Wenzel (Baltimore: Williams and Wilkins, 1997), pp. 491-514; David J. Weber, Deverick Anderson, and William A. Rutala, [The Role of the Surface Environment in Healthcare-Associated Infections](#), *Current Opinion in Infectious Diseases* 26:4 (2013), pp. 338-344; David J. Weber *et al.*, “Role of Hospital Surfaces in the Transmission of Emerging Health-Care Associated Pathogens: Norovirus, *Clostridium Difficile*, and *Acinetobacter* Species,” *American Journal of Infection Control* 38 (2010), pp. S25-33.
- ¹⁰⁹ Adapted from Philip C. Carling and Susan S. Huang, [Improving Healthcare Environmental Cleaning and Disinfection: Current and Evolving Issues](#), *Infection Control and Hospital Epidemiology* 34:5, Special Topic Issue: The Role of the Environment in Infection Prevention (May, 2013), p. 510.
- ¹¹⁰ Franz Allerberger *et al.*, [Routine Surface Disinfection in Health Care Facilities: Should We Do It?](#), *American Journal of Infection Control* 30:5 (August, 2002), pp. 318-9; The Centers for Disease Control and Prevention (CDC), Healthcare Infection Control Practices Advisory Committee (HICPAC), [Guidelines for Environmental Infection Control in Health-Care Facilities: Recommendations of CDC and the Healthcare Infection Control Practices Advisory Committee \(HICPAC\)](#) (2003), p. 75; Marcus Dettenkofera and Robert C. Spencer, “Importance of Environmental Decontamination: A Critical View,” *Journal of Hospital Infection* 65:Supplement 2 (June, 2007), pp. 55-57; Adam P. Fraise, “Decontamination of the Environment and Medical Equipment in Hospitals,” in *Russell, Hugo and Ayliffe’s Principles and Practice*

of Disinfection, Preservation & Sterilization, 4th Edition, ed. Adam P. Fraise, Peter A. Lambert, and Jean-Yves Maillard (Malden, MA: Blackwell Publishing, 2004), p. 572; Jürgen Gebel, Stefanie Gemein, and Martin Exner, "Surface Cleaning and Disinfection: Insight into the Situation in Germany and Europe," *Healthcare Infection* 18 (2013), pp. 31-36; Bala Hota, [Contamination, Disinfection, and Cross-Colonization: Are Hospital Surfaces Reservoirs for Nosocomial Infection?](#) *Clinical Infectious Diseases* 39:8 (October, 2014), p. 1182; The Centers for Disease Control and Prevention (CDC), [Guideline for Disinfection and Sterilization in Healthcare Facilities, 2008](#), ed. William A Rutala, *et al.* (2008), p. 108; Donald Vesley *et al.*, "A Cooperative Microbiological Evaluation of Floor-cleaning Procedures in Hospital Patient Rooms," *Health Laboratory Science* 7:4 (October, 1970), pp. 256-264; Deborah S. Yokoe *et al.*, [Executive Summary: A Compendium of Strategies to Prevent Healthcare-Associated Infections in Acute Care Hospitals: 2014 Updates](#), *Infection Control and Hospital Epidemiology* 35:8 (August, 2014), p. 967-977.

¹¹¹ Dennis G. Maki *et al.*, "Relation of the Inanimate Hospital Environment to Endemic Nosocomial Infection," *New England Journal of Medicine* 307 (1982), p. 1562.

¹¹² "Standard Precautions are the minimum infection prevention practices that apply to all patient care, regardless of suspected or confirmed infection status of the patient, in any setting where healthcare is delivered. These practices are designed to both protect HCP [health care professionals] and prevent HCP from spreading infections among patients. Standard Precautions include: 1) hand hygiene, 2) use of personal protective equipment (e.g., gloves, gowns, masks), 3) safe injection practices, 4) safe handling of potentially contaminated equipment or surfaces in the patient environment, and 5) respiratory hygiene/cough etiquette." The Centers for Disease Control and Prevention (CDC), [Guide to Infection Prevention for Outpatient Settings: Minimum Expectations for Safe Care](#) (July, 2011), p. 8; The Centers for Disease Control and Prevention (CDC), Healthcare Infection Control Practices Advisory Committee (HICPAC), [Guidelines for Environmental Infection Control in Health-Care Facilities: Recommendations of CDC and the Healthcare Infection Control Practices Advisory Committee \(HICPAC\)](#) (2003), p. 84. See also: The Centers for Disease Control and Prevention (CDC), Healthcare Infection Control Practices Advisory Committee (HICPAC), [Guideline for Isolation Precautions: Preventing Transmission of Infectious Agents in Healthcare Settings](#) (2007), pp. 143-144; Edward Septimus *et al.*, [Approaches for Preventing Healthcare-Associated Infections: Go Long or Go Wide?](#), *Infection Control and Hospital Epidemiology* 35:S2, A Compendium of Strategies to Prevent Healthcare-Associated Infections in Acute Care Hospitals: 2014 Updates (September, 2014), p. 799; David J. Weber and William A. Rutala, [Understanding and Preventing Transmission of Healthcare-Associated Pathogens Due to the Contaminated Hospital Environment](#), *Infection Control and Hospital Epidemiology* 34:5, Special Topic Issue: The Role of the Environment in Infection Prevention (May, 2013), pp. 449-452; Alejandro Ramirez *et al.*, [Preventing Zoonotic Influenza Virus Infection](#), *Emerging Infectious Diseases* 12:6 (June, 2006), pp. 998-1000.

¹¹³ A recent review of research on 'no-touch' automated room disinfection (NTD) – by a scientist who has been distinctly bullish on hospital infection control – concludes: "Given the present lack of clinical studies demonstrating the relative effectiveness of NTD systems in routine clinical use compared with traditional cleaning practice, it is premature to present recommendations for the use of such systems." Philip C. Carling, [The Need for Clinically Relevant Studies of Non-Touch Disinfecting Systems](#), *Journal of Hospital Infection* 84:4 (August, 2013), p. 310. A subsequent review agrees: "Does a novel cleaning strategy reduce the risk of health care-associated infection and is it a cost-effective use of scarce health care resources?" Lack of evidence on patient outcome remains the single most important deficit when proposing changes to routine cleaning practice. It is also true to say that the role of cleaning itself for controlling healthcare-associated infection is still hotly debated." Brett G. Miller *et al.*, [Moving Forward with Hospital Cleaning](#), *Journal of Hospital Infection* 41:11 (November, 2013), p. 1138. See also: Stephanie J. Dancer, [Floor Wars: The Battle for 'Clean' Surfaces](#), *Journal of Hospital Infection* 84:4 (August, 2013), pp. 339-340; Stephanie J. Dancer, [Controlling Hospital-Acquired Infection: Focus on the Role of the Environment and New Technologies for Decontamination](#), *Clinical Microbiology Reviews* 27:4 (October, 2014), pp. 665-690.

¹¹⁴ See, for example: USDA-APHIS, [Foot-and-Mouth Disease Standard Operating Procedures: 1. Overview of Etiology and Ecology](#), FADPRReP (August, 2013), pp. 1-8.

-
- ¹¹⁵ See, for example: Robert F. Sellers and J. Parwer, [Airborne Excretion of Foot-and-Mouth Disease Virus](#), *Journal of Hygiene* 67:4 (December, 1969), p. 676; Paul Suttmoller *et al.*, [Review: Control and Eradication of Foot-and-Mouth Disease](#), *Virus Research* 91:1 (2003), pp. 101-144; Alex I. Donaldson and Soren Alexandersen, [Predicting the Spread of Foot and Mouth Disease by Airborne Virus](#), *Revue Scientifique et Technique, OIE* 21:3 (2002), pp. 569-575; Alex I. Donaldson *et al.*, [Relative Risks of the Uncontrollable \(Airborne\) Spread of FMD by Different Species](#), *The Veterinary Record* 148:19 (May 12, 2001), pp. 600-602; John Gloster *et al.*, “Re-Assessing the Likelihood of Airborne Spread of Foot-and-Mouth Disease at the Start of the 1967-1968 UK Foot-and-Mouth Disease Epidemic,” *Epidemiology and Infection* 133:5 (October, 2005), pp. 767-783; Michael Graeme Garner and Rob M. Cannon, [Potential for Wind-Borne Spread of Foot-and-Mouth Disease Virus in Australia](#), Report prepared for the Australian Meat Research Corporation (1995); John Gloster *et al.*, “Airborne Spread of Foot-and-Mouth Disease – Model Intercomparison,” *Veterinary Journal* 183:3 (March, 2010), pp. 278-286; G.A. König *et al.*, “Sequence Data and Evidence of Possible Airborne Spread in the 2001 Foot-and-Mouth Disease Epidemic in the UK,” *The Veterinary Record* 165:14 (2009), pp. 410-412; David Schley, Laura Burgin, and John Gloster, [Predicting Infection Risk of Airborne Foot-and-Mouth Disease](#), *Journal of the Royal Society Interface* 6:34 (May 6, 2009), pp. 455–462.
- ¹¹⁶ See, for example: Robert F. Sellers, Alex I. Donaldson, and K.A.J. Herniman, [Inhalation, Persistence and Dispersal of Foot-and-Mouth Disease Virus by Man](#), *Journal of Hygiene* 68:4 (December, 1970), pp. 565-573; Robert F. Sellers, K.A.J. Herniman and J.A. Mann, “Transfer of Foot-and-Mouth Disease Virus in the Nose of Man from Infected to Non-Infected Animals,” *Veterinary Record* 89:16 (October 16, 1971), pp. 447-449; and subsequent, spirited exchanges in the British journal of veterinary medicine: Alex I. Donaldson and Robert F. Sellers, “Transmission of FMD by People,” *The Veterinary Record* 153:9 (August 30, 2003), pp. 279-80; T. O. Jones, “Foot-and-Mouth Disease and the Use of Face Masks,” *The Veterinary Record* 161:25 (December 22, 2007) pp. 863-864; Ian Mawhinney *et al.*, Comment on “Foot-and-Mouth Disease and the Use of Face Masks,” *The Veterinary Record* 162:2 (January 12, 2008), pp. 62-63; T. O. Jones, Comment on “Foot-and-Mouth Disease and the Use of Face Masks,” *The Veterinary Record* 162:4 (January 26, 2008), pp. 131-132; Alex I. Donaldson, Comment on “Foot-and-Mouth Disease and the Use of Face Masks,” *The Veterinary Record* 162:5 (February 2, 2008), pp. 162-163; Robert F. Sellers, Comment on “Foot-and-Mouth Disease and the Use of Face Masks,” *The Veterinary Record* 162:7 (February 16, 2008), p. 223-224.
- ¹¹⁷ Sandra F. Amass *et al.*, [Procedures for Preventing the Transmission of Foot-and-Mouth Disease Virus by People](#), *Veterinary Microbiology* 103:3-4 (November, 2004), pp. 143-149; Caroline F. Wright *et al.*, “Short-Lived Carriage of Foot-and-Mouth Disease Virus in Human Nasal Cavities after Exposure to Infected Animals,” *The Veterinary Record* 167:24 (December 11, 2010), pp. 928-931; USDA, APHIS, [NAHEMS Guidelines: Vaccination For Contagious Diseases, Appendix A: Foot-And-Mouth Disease](#) (April, 2011), p. 7.
- ¹¹⁸ There are many such examples. Among the most costly has been policy justified to remediate risks that are supposedly associated with FMD-immunized animals as “carriers” of FMDV (e.g., in justifying OIE-certified extensions of restrictions on trade with countries that vaccinate). Once again there is some microbial “evidence” that carriers among commercial livestock in the U.S. (e.g., FMD vaccinated or recovered cattle, hogs, sheep, and goats) may harbor virus and thereby spread infection. However, decades of field observations around the world and all-out experimental efforts to demonstrate such infection have consistently failed, in all but very exceptional cases (some experiments with African buffalo). After reviewing more than fifty years of research on this subject (FMDV carriers), Dorothy W. Geale *et al.* recently concluded: “There is no evidence in the literature that persistently infected domestic livestock function as reservoirs of FMDV. Experts are coming to conclude that only African buffalo are reservoirs of FMDV and not cattle or any other ruminant species.” Dorothy W. Geale *et al.*, “A Review of OIE Country Status Recovery Using Vaccinate-to-Live Versus Vaccinate-to-Die Foot-and-Mouth Disease Response Policies II: Waiting Periods After Emergency Vaccination in FMD Free Countries,” *Transboundary and Emerging Diseases* (October, 2013), p. 9. Soren Alexandersen *et al.* published a similar conclusion a decade earlier in “The Pathogenesis and Diagnosis of Foot-and-Mouth Disease,” *Journal of Comparative Pathology* 129:1 (July, 2003), pp 20-22, but OIE manuals still credit the microbiological evidence and commonsense inference (that “carriers” could spread disease) over proven clinical outcomes (that “carriers” do not normally spread disease).

-
- ¹¹⁹ Peggy L. Schmidt *et al.*, [The Association Between Cleaning and Disinfection of Lairage Pens and the Prevalence of *Salmonella Enterica* in Swine at Harvest](#), *Journal of Food Protection* 67:7 (July, 2004), p. 1387.
- ¹²⁰ Peggy L. Schmidt *et al.*, [The Association Between Cleaning and Disinfection of Lairage Pens and the Prevalence of *Salmonella Enterica* in Swine at Harvest](#), *Journal of Food Protection* 67:7 (July, 2004), pp. 1386-1387. See, for example, one of the most thoroughly researched and frequently cited studies on the effectiveness of farm-gate biosecurity in a FMD outbreak: Nick Honhold, Tony Taucher, and Nick Taylor. "The Involvement of Milk Tankers in the Spread of Foot and Mouth Disease in Cumbria, 2001," The University of Reading (2004), Appendix 5 in [Detailed Investigation of the Methods and Characteristics of Spread of FMD in Specific Geographic Clusters and the Effects of Control Measures during the 2001 Epidemic](#), Final Project Report to DEFRA (2005), pp. 15, 21-22. As Schmidt *et al.* caution, this is, in fact, a case control study, and much of the weight of the argument (e.g., explicitly in eliminating every, supposedly possible alternative explanations for the surprising lack of evidence associating high-risk tanker traffic and disease spread) depends on the authority of conventional wisdom (that tankers spread disease, unless they are decontaminated at the farm gate), even though the authors also report that data to support that wisdom have never been well collected or analyzed.
- ¹²¹ After the third phase of a 6-year study by the Committee on Microbial Contamination of Surfaces, of the Laboratory Section of the American Public Health Association: "The Committee concludes that its arbitrary guidelines are achievable but stresses that they are quantitative only, that recontamination occurs quickly in areas where there is uncontrolled human activity, and that they make no claims for a direct relationship between these standards of cleanliness and the risk of infection in a hospital." Donald Vesley *et al.*, "A Cooperative Microbiological Evaluation of Floor-cleaning Procedures in Hospital Patient Rooms," *Health Laboratory Science* 7:4 (October, 1970), pp. 256-264. Seven years later, the Society for Healthcare Epidemiology of America (SHEA) notes that evidence of infection-control effectiveness for its recommendations to "Ensure cleaning and disinfection of equipment and the environment" remained very weak "(quality of evidence: III for equipment, III for environment)." Deborah S. Yokoe *et al.*, [Executive Summary: A Compendium of Strategies to Prevent Healthcare-Associated Infections in Acute Care Hospitals: 2014 Updates](#), *Infection Control and Hospital Epidemiology* 35:8 (August, 2014), p. 969. See also: Jonathan A. Otter, Saber Yezli, and Gary L. French, "The Role Played by Contaminated Surfaces in the Transmission of Nosocomial Pathogens," *Infection Control and Hospital Epidemiology* 32:7 (July, 2011), pp. 687-699; William A. Rutala and David J. Weber. [Disinfection and Sterilization in Health Care Facilities: What Clinicians Need to Know](#), *Clinical Infectious Diseases* 39:5 (September 1, 2004).
- ¹²² The image is from Andrew Percey, [Internet Marketing Strategies That Leave Time for the Rest of Your Business](#) (March 20, 2013).
- ¹²³ The image is from Big Fish Media, [How to Increase Your Advertising Results by Applying the 80/20 Rule](#) (2015).
- ¹²⁴ See, for example: United States Coast Guard, [Performance Improvement Guide](#), 5th Ed. (September, 2012), p. 155; and [Risk-Based Decision-Making Guidelines](#) 5th Ed. (2000), "Chapter 3: Pareto Analysis", [Volume 3: Procedures for Assessing Risks](#), pp. 3-5 and "Pareto Analysis," in "Volume 4: Resources for Risk-based Decision Making," p. 2.
- ¹²⁵ See, for example: Brett Sitzlar *et al.*, [An Environmental Disinfection Odyssey: Evaluation of Sequential Interventions to Improve Disinfection of *Clostridium difficile* Isolation Rooms](#), *Infection Control and Hospital Epidemiology* 34:5, Special Topic Issue: The Role of the Environment in Infection Prevention (May 2013), pp. 459-465; John M. Boyce, "Environmental Contamination Makes An Important Contribution To Hospital Infection," *Journal of Hospital Infection* 65:Supplement 2, (June 2007), pp. 50-54; Rose A. Cooper, *et al.* [Monitoring the Effectiveness of Cleaning in Four British Hospitals](#), *American Journal of Infection Control* 35: 5 (June 2007), pp. 338-341.
- ¹²⁶ Bala Hota, [Contamination, Disinfection, and Cross-Colonization: Are Hospital Surfaces Reservoirs for Nosocomial Infection?](#), *Clinical Infectious Diseases* 39:8 (October, 2014), pp. 1182-1189; Brett Sitzlar *et al.*, [An Environmental Disinfection Odyssey: Evaluation of Sequential Interventions to Improve Disinfection of *Clostridium difficile* Isolation Rooms](#), *Infection Control and Hospital Epidemiology* 34:5, Special Topic Issue: The Role of the Environment in Infection Prevention (May 2013), pp. 459-465; Joint

Commission, [It's All on the Surface: Establishing Protocols for Cleaning and Disinfecting Environmental Surface Areas](#), *Environment of Care News* 13:3 (March, 2010), pp. 6-11. See, also: Philip C. Carling *et al.*, "Improving Cleaning of the Environment Surrounding Patients in 36 Acute Care Hospitals," *Infection Control and Hospital Epidemiology* 29:11 (November, 2008), pp. 1035-41; Philip C. Carling *et al.*, [Intensive Care Unit Environmental Cleaning: an Evaluation in Sixteen Hospitals Using a Novel Assessment Tool](#), *Journal of Hospital Infection* 68 (January, 2008), pp. 39-44; Alice Guh and Philip Carling, [Options for Evaluating Environmental Cleaning](#) (CDC, December, 2010); William A Rutala, [Best Practices for Surface Disinfection](#), Association for Professionals in Infection Control and Epidemiology (APIC) Webinar (April 30, 2012); Sean Barnes *et al.*, [Preventing the Transmission of Multidrug-Resistant Organisms: Modeling the Relative Importance of Hand Hygiene and Environmental Cleaning Interventions](#), *Infection Control and Hospital Epidemiology* 35:9 (September, 2014), pp. 1156-1162; Bala Hota *et al.*, "Interventional Evaluation of Environmental Contamination by Vancomycin-resistant Enterococci [VRE]: Failure of Personnel, Product, or Procedure?," *Journal of Hospital Infection* 71:2 (February, 2009), pp. 123-131; Bala Hota, "The Effect of Observation of Environmental Workers on Thoroughness and Outcome of Environmental Cleaning," *Program and Abstracts of the 43rd Interscience Conference on Antimicrobial Agents and Chemotherapy (ICAAC)* (Washington DC: American Society for Microbiology Press, 2003). p. 369.

¹²⁷ Philip C. Carling, [Towards Eliminating Clostridium difficile Infections \(CDI\) in Illinois](#), presentation to the Illinois Campaign to Eliminate *Clostridium difficile* (July, 2012), slide 28.

¹²⁸ See, for example: Curtis J. Donskey, [Preventing Transmission of Clostridium difficile: Is the Answer Blowing in the Wind?](#), *Clinical Infectious Diseases* 50:11 (June 1, 2010), pp. 1458-1461; Brittany C. Eckstein *et al.*, [Reduction of Clostridium Difficile and Vancomycin-resistant Enterococcus Contamination of Environmental Surfaces after an Intervention to Improve Cleaning Methods](#), *BMC Infectious Diseases* 7 (June 21, 2007), p. 61.

¹²⁹ Becky A. Miller credits this slide to Dr. Philip C. Carling – a strong advocate of environmental monitoring and disinfection in her presentation, [The Healthcare Environment: Evaluating Cleaning Practices and Improving Compliance](#), to the Illinois Campaign to Eliminate *Clostridium difficile* (July 18, 2012), slide 43. See also: Alice Guh and Philip Carling, [Options for Evaluating Environmental Cleaning](#) (CDC, December, 2010); and Philip C. Carling, [Towards Eliminating Clostridium difficile Infections \(CDI\) in Illinois](#), presentation to the Illinois Campaign to Eliminate *Clostridium difficile* (July, 2012).

¹³⁰ The estimate of 10-70% effectiveness comes from R. Douglas Scott II, [The Direct Medical Costs of Healthcare-Associated Infections in U.S. Hospitals and the Benefits of Prevention](#) (CDC, March, 2009), p. 7; and Stephan Harbarth, Hugo Sax, and Petra Gastmeier, [The Preventable Proportion of Nosocomial Infections: An Overview of Published Reports](#), *Journal of Hospital Infection* 54:4 (August, 2003), pp. 258-266. After reviewing 30 research reports, they conclude (p. 260): "It is of note that the most important reduction effect was identified for nosocomial bloodstream infections related to the use of central venous catheters. . . . To date, it remains unclear to what extent these nosocomial infections are avoidable under real-life hospital conditions and what represents the irreducible minimum." See also: *Infection Control and Hospital Epidemiology* 34:5, Special Topic Issue: [The Role of the Environment in Infection Prevention](#) (May 2013); Alice Guh and Philip Carling, [Options for Evaluating Environmental Cleaning](#) (CDC, December, 2010); The Centers for Disease Control and Prevention (CDC), Healthcare Infection Control Practices Advisory Committee (HICPAC), [Guideline for Isolation Precautions: Preventing Transmission of Infectious Agents in Healthcare Settings](#) (2007), p. 45.

¹³¹ For a concise overview of the division of federal responsibilities, see The Centers for Disease Control and Prevention (CDC), Healthcare Infection Control Practices Advisory Committee (HICPAC), Morbidity and Mortality Weekly Report (MMWR), Appendix A: [Regulatory Framework for Disinfectants and Sterilants](#), Recommendations and Reports 52:RR17 (December 19, 2003), pp. 62-64. A key complication for disinfectants is the division of responsibility between EPA and FDA, which have significantly different registration procedures and jurisdiction over various levels and applications of disinfectant. See, for example: United States, Food and Drug Administration (FDA) and U.S. Environmental Protection Agency (EPA), [Memorandum of Understanding Between the Food and Drug Administration, Public Health Service, Department of Health and Human Services, and the Environmental Protection Agency: Notice](#)

[Regarding Matters of Mutual Responsibility – Regulation of Liquid Chemical Germicides Intended for Use On Medical Devices](#) MOU 225-93-4005 (March 11, 2009).

- ¹³² United States Department of Agriculture, APHIS, [Potential Pesticides To Use Against The Causative Agents of Selected Foreign Animal Diseases in Farm Settings](#) (October 31, 2012); United States, [Federal Insecticide, Fungicide, and Rodenticide Act \(FIFRA\)](#), 7 U.S.C. §136 *et seq.* (1996). See also: The Centers for Disease Control and Prevention (CDC), Healthcare Infection Control Practices Advisory Committee (HICPAC), Morbidity and Mortality Weekly Report (MMWR), Appendix A: [Regulatory Framework for Disinfectants and Sterilants](#), Recommendations and Reports 52:RR17 (December 19, 2003), pp. 62-64. Note: “Sodium hypochlorite solutions are inexpensive and effective broad-spectrum germicidal solutions. . . . Generic sources of sodium hypochlorite include household chlorine bleach or reagent grade chemical. . . . Many chlorine bleach products available in grocery and chemical-supply stores are not registered by the EPA for use as surface disinfectants. Use of these chlorine products as surface disinfectants is considered by the EPA to be an ‘unregistered use.’ EPA encourages the use of registered products because the agency reviews them for safety and performance when the product is used according to label instructions. When unregistered products are used for surface disinfection, users do so at their own risk.” The Centers for Disease Control and Prevention (CDC), Healthcare Infection Control Practices Advisory Committee (HICPAC), [Guidelines for Environmental Infection Control in Health-Care Facilities: Recommendations of CDC and the Healthcare Infection Control Practices Advisory Committee \(HICPAC\)](#) (2003), p. 77.
- ¹³³ United States Department of Agriculture, APHIS, “Use Directions,” [FIFRA Section 18 Emergency Exemption Label](#) (May 23, 2013), p. 1.
- ¹³⁴ William A Rutala *et al.*, [Disinfection, Sterilization Guideline for Disinfection and Sterilization in Healthcare Facilities, 2008](#) for the CDC, [Healthcare Infection Control Practices Advisory Committee](#) (2008); The Centers for Disease Control and Prevention (CDC), [Guideline for Disinfection and Sterilization in Healthcare Facilities, 2008](#), ed. William A Rutala, *et al.* (2008), p. 105.
- ¹³⁵ The Centers for Disease Control and Prevention (CDC), [Guideline for Disinfection and Sterilization in Healthcare Facilities, 2008](#), ed. William A Rutala, *et al.* (2008), p. 105, emphasis added. See also: William A. Rutala, [‘Best’ Practices for Surface Disinfection](#), Association for Professionals in Infection Control and Epidemiology (APIC) Webinar (April 30, 2012); and William A. Rutala and David J. Weberk, [Disinfection and Sterilization in Health Care Facilities: What Clinicians Need to Know](#), *Clinical Infectious Diseases* 39:5 (September 1, 2004), p. 707, also published as Chapter 20 of *Bennett and Brachman’s Hospital Infections*, ed. William R. Jarvis (Philadelphia: Lippincott, Williams and Wilkins, 2014).
- ¹³⁶ In a webinar on [‘Best’ Practices for Surface Disinfection](#) for the Association for Professionals in Infection Control and Epidemiology (APIC) (April 30, 2012), Bill Rutala observed: “For low-level disinfection . . . we have been using essentially the same products for the last 30-plus years” (e.g., alcohol, chlorine, phenolic, QUAT, hydrogen peroxide). These products have proven very effective, no matter how they are applied, with just 30 seconds of contact time. . . . The policy of contact time of at least one minute drew the attention of Joint Commission Surveyors from [The Joint Commission](#) [noting that EPA registration stipulated longer contact times], but they did not object: ‘If you’re following your policy, it’s fine.’” The Centers for Disease Control and Prevention (CDC), [Guideline for Disinfection and Sterilization in Healthcare Facilities, 2008](#), ed. William A Rutala, *et al.* (2008), p. 105; Kelly M. Pyrek, [Environmental Hygiene: What We Know from Scientific Studies](#), *Infection Control Today* (August 30, 2012). See also: William A. Rutala, “Disinfection and Sterilization: Successes and Challenges,” in *Disinfection, Sterilization, and Antisepsis: Principles, Practices, Current Issues, New Research, and New Technologies*, ed. William A. Rutala (Washington, DC: Association of Practitioners in Infection Control, 2010).
- ¹³⁷ Philip C. Carling, and Susan S. Huang, [Improving Healthcare Environmental Cleaning and Disinfection: Current and Evolving Issues](#), *Infection Control and Hospital Epidemiology* 34:5, Special Topic Issue: The Role of the Environment in Infection Prevention (May, 2013), pp. 510-511.
- ¹³⁸ Scientists working for disinfectant manufacturers suggest that the EPA-mandated contact times are “highly artificial and have little relevance to real world applications” and are best considered “only a starting point” for effective times that are better determined by end-users. Personal email exchanges with a chemist and a chemical engineers (names withheld on request) in the compliance division of disinfectant

manufacturers (April-May, 2015). As further evidence of the over-the-top quality of these mandates, they pointed out that pharmaceutical, food, and beverage manufacturers have their own sanitation guidelines that specify much shorter contact times than those EPA “starting points.” According to the authoritative Current Good Manufacturing Practice (CGMP), contact time for standard chlorine solutions range from 7-30 **seconds** (vs. 10-30 **minutes** on-label), depending on the temperature. See, for example, U.S. Food and Drug Administration, [FDA Food Code 2009: Chapter 4 - Equipment, Utensils & Linens](#) (October 29, 2013), section 4-703.11.

¹³⁹ See, for example: Marcus Dettenkofer and Robert C. Spencer, “Importance of Environmental Decontamination a Critical View,” *Journal of Hospital Infection* 65:Supplement 2 (June, 2007), pp. 55-57.

¹⁴⁰ “Decontamination is rarely the same as sterilisation; in the field, 100% decontamination is unlikely to be achieved in all situations . . . Soaps and detergents are usually not considered good disinfectants, but they are essential for the cleaning needed before many of the decontamination procedures . . . In most cases, the primary aim is the removal of organic material, dirt or grease from surfaces to be decontaminated. Most industrial and domestic brands of soaps and detergents are satisfactory . . . Soaps and detergents are not consistently effective against bacteria, but are effective disinfectants in their own right for almost all Category A viruses because of their effect on the outer lipid envelope.” Animal Health Australia, Standing Council on Primary Industries, [Australian Veterinary Emergency Plan \(AUSVETPLAN\), Operational Procedures Manual: Decontamination](#), Version 3.2 (2008), pp. 11, 20. See also: Stephanie J. Dancer, [Hospital Cleaning in the 21st Century](#), *European Journal of Clinical Microbiology and Infectious Disease* 30:12 (December, 2011), p. 1473.

¹⁴¹ Detergent is even more effective against “enveloped” viruses, which are surrounded by a distinctly soluble, lipid membrane. Detergents can dissolve that membrane and, in effect, deactivate the RNA it contains. Unfortunately, FMDV is a species of the *Aphthovirus* genus in the *Picornaviridae* family, which is not enveloped. FMDV is therefore more resistant to disinfection than enveloped viruses but still much less resistant than most other pathogens, particularly bacteria or sporeformers, with less soluble membranes. See, for example: Gavin R. Thomson, Roy G. Bengis, and Corrie C. Brown, “Picornavirus Infections” in *Infectious Diseases of Wild Mammals*, 3rd Edition, eds. Elizabeth S. Williams and Ian K. Barker (Ames, IA: ISU Press, 2001), pp. 119-130.

¹⁴² See, for example: Bala Hota *et al.*, “Interventional Evaluation of Environmental Contamination by Vancomycin-resistant Enterococci [VRE]: Failure of Personnel, Product, or Procedure?,” *Journal of Hospital Infection* 71:2 (February, 2009), pp. 123-131; Bala Hota, “The Effect of Observation of Environmental Workers on Thoroughness and Outcome of Environmental Cleaning,” *Program and Abstracts of the 43rd Interscience Conference on Antimicrobial Agents and Chemotherapy (ICAAC)* (Washington DC: American Society for Microbiology Press, 2003), p. 369; and [Contamination, Disinfection, and Cross-Colonization: Are Hospital Surfaces Reservoirs for Nosocomial Infection?](#), *Clinical Infectious Diseases* 39:8 (October, 2014), pp. 1182-1189.

¹⁴³ This is NOT to claim that the costs and benefits are equivalent in the two environments. Note, for example, that farm vehicles and lanes are more likely to have porous, uneven surfaces loaded with organic matter (requiring better cleaning and longer disinfectant contact time) and to be more amenable to washing techniques that extend dwell time (such as foaming) than floors in a healthcare facility. So, long contact times (weather permitting) may still be more “worth it” on farms than in hospitals. But in both cases the net gain in **clinical** effectiveness with extended contact time is unproven and inherently limited by the thoroughness of pre-cleaning. Thoroughness has proven a problem in hospitals and is apt to be much tougher to achieve and maintain on a farm, where there are likely to be greater challenges and fewer resources.

¹⁴⁴ In the case of avian influenza: “Many countries have implemented routine disinfection programmes for control and prevention of avian influenza and the use of these chemicals forms part of outbreak management. It is evident from field observations that there has been considerable misuse of these chemicals. Cleaning is not always used as a preliminary step prior to disinfection, and many disinfectants are applied to areas with high loads of organic matter that reduces the efficacy of the disinfectants. In other cases, contact times are too short for virus inactivation. Formal studies have not been conducted to evaluate the cost-effectiveness of disinfection programmes applied in and around villages for the prevention of avian influenza.” Leslie Sims, [Intervention Strategies to Reduce the Risk of Zoonotic](#)

[Infection with Avian Influenza viruses: Scientific Basis, Challenges and Knowledge Gaps](#), *Influenza and Other Respiratory Viruses* 7:2 (September, 2013), p. 21.

¹⁴⁵ See, for example: Stephanie J. Dancer, [Floor Wars: The Battle for 'Clean' Surfaces](#), *Journal of Hospital Infection* 84:4 (August, 2013), pp. 339-340; and Jonathan A. Otter *et al.*, "A Request for an Alliance in the Battle for Clean and Safe Hospital Surfaces," *Journal of Hospital Infection* 84:4 (August, 2013), pp. 341-342.

¹⁴⁶ This table is adapted from S.H. Dalwadi and J.H. Simmonds, [Cleaning for Health Report 2012/2013](#) for the World Federation of Building Service Contractors, 2nd Edition (April, 2013), pp. 7-8; William A. Rutala, and David J. Weber, "Surface Disinfection: Should We Do It?" *Journal of Hospital Infection* 48:Supplement A (August, 2001), pp. S64-S68; and William A. Rutala and David J. Weber, "The Benefits of Surface Disinfection," *American Journal of Infection Control* 32:4 (June, 2004) p. 227.

¹⁴⁷ For example, a review of related research through 2014 concludes: "Although contamination of the inanimate environment by microorganisms has long been recognized, its significance is unclear. . . . Little evidence exists that proves that decreasing environmental contamination with MRSA leads to decreases in rates of patient infections. The most compelling are data that prove that contamination of the environment leads to contamination of health care workers' gowns and gloves, both of which could result in patient colonization. Other studies have shown that cleaning the inanimate environment or isolating patients caused cessation of outbreaks of MRSA, but interpretation is limited because of the use of multiple interventions. . . . Three types of available solutions can be used during cleaning: detergents, which remove organic material and suspend grease or oil; disinfectants, which rapidly kill or inactivate infectious particles; and detergent-disinfectants, which achieve both aims. Conclusive data do not exist to prove that the routine disinfection of hospital surfaces is preferable to the use of detergent alone, and, therefore, routine use of detergent-disinfectants is based largely on consensus and logistic considerations. . . . Studies conclusively demonstrating an improvement in nosocomial infection rates following improved cleaning need to be performed." Bala Hota, [Contamination, Disinfection, and Cross-Colonization: Are Hospital Surfaces Reservoirs for Nosocomial Infection?](#) *Clinical Infectious Diseases* 39:8 (October, 2014), pp. 1182, 1185-1186; Stephanie J. Dancer, [Hospital Cleaning in the 21st Century](#), *European Journal of Clinical Microbiology and Infectious Disease* 30:12 (December, 2011), pp. 1473-1481; Ann Cozad and Rhonda D. Jones, "Disinfection and the Prevention of Infectious Disease," *American Journal of Infection Control* 31:4 (June, 2003), pp. 243-254.

¹⁴⁸ Graham A. J. Ayliffe, B. J. Collins, and E.J.L. Lowbury, "Cleaning and Disinfection of Hospital Floors," *British Medical Journal [BMJ]* 2:551 (August 20, 1966), pp. 444-445.

¹⁴⁹ Graham A. J. Ayliffe, B. J. Collins, and E.J.L. Lowbury, with J. R. Babb and H. A. Lilly, "Ward Floors and Other Surfaces as Reservoirs of Hospital Infection," *Journal of Hygiene* 65:4 (December, 1967), p. 533.

¹⁵⁰ See, for example: Adam P. Fraiese, "Decontamination of the Environment and Medical Equipment in Hospitals," in *Russell, Hugo and Ayliffe's Principles and Practice of Disinfection, Preservation and Sterilization*, 4th Edition, ed. Adam P. Fraiese, Peter A. Lambert, Jean-Yves Maillard (Malden, MA: Blackwell Publishing, 2004), p. 572; D. Danforth *et al.*, "Nosocomial Infections on Nursing Units with Floors Cleaned with a Disinfectant Compared with Detergent," *Journal of Hospital Infection* 10 (1987), pp. 229-235; Sasi Dharan *et al.*, "Routine Disinfection of Patients' Environmental Surfaces: Myth or Reality?," *Journal of Hospital Infection* 42:2 (June, 1999), pp. 113-117.

¹⁵¹ "It is unlikely that floors will cause the spread of infection. . . In most cases, routine cleaning is sufficient to prevent the spread of infection. Routine cleaning involves the use of detergent – typically soap or another medical-grade disinfectant. . . . The degree of scrubbing involved in cleaning is probably the most critical element in determining whether cleaning and disinfecting are ultimately effective." Joint Commission, [It's All on the Surface: Establishing Protocols for Cleaning and Disinfecting Environmental Surface Areas](#), *Environment of Care News* 13:3 (March, 2010), p. 7. See also: Sasi Dharan *et al.*, "Routine Disinfection of Patients' Environmental Surfaces: Myth or Reality?," *Journal of Hospital Infection* 42:2 (June, 1999), pp. 113-117; D. Danforth *et al.*, "Nosocomial Infections on Nursing Units with Floors Cleaned with a Disinfectant Compared with Detergent," *Journal of Hospital Infection* 10 (1987), pp. 229-235; Stephanie J. Dancer, [Floor Wars: the Battle for 'Clean' Surfaces](#), *Journal of Hospital Infection* 84:4 (August, 2013), pp. 339-340.

-
- ¹⁵² S.H. Dalwadi and J.H. Simmonds, [Cleaning for Health Report 2012/2013](#) for the World Federation of Building Service Contractors, 2nd Edition (April, 2013), p. 9.
- ¹⁵³ The Centers for Disease Control and Prevention (CDC), Healthcare Infection Control Practices Advisory Committee (HICPAC), [Guidelines for Environmental Infection Control in Health-Care Facilities: Recommendations of CDC and the Healthcare Infection Control Practices Advisory Committee \(HICPAC\)](#) (2003), pp. 73-84. “While there are no data that demonstrate a reduction in hospital-acquired infection rates with the use of surface disinfection of floors, available data show a reduction in microbial load associated with the use of some disinfectants. In addition, the use of a disinfectant throughout the hospital simplifies training and use. Given the minimal extra cost, the use of disinfectants on floors is reasonable. . . . In summary, while non-critical surfaces are not commonly associated with transmission of infections to patients, one should clean and disinfect surfaces on a regular basis. . . . It is reasonable to disinfect floors given the minimal cost and added antimicrobial activity. Additional studies should be undertaken to determine the clinical impact of current surface disinfection practices.” William A. Rutala and David J. Weber, “Surface Disinfection: Should We Do It?” *Journal of Hospital Infection* 48:Supplement A (August, 2001), p. S67.
- ¹⁵⁴ Franz Allerberger *et al.*, [Routine Surface Disinfection in Health Care Facilities: Should We Do It?](#), *American Journal of Infection Control* 30:5 (August, 2002), pp. 318-319. The CDC has published a [Disclosure of Financial Interests and Relationships \(2000- July 2004\)](#) for HICPAC members: “William A. Rutala: Honoraria from Advanced Sterilization Products, Kimberly-Clark; consultation with Advanced Sterilization Products, Aesculap, Clorox, 3M, SC Johnson, Intelligent Biocides, Metrex; and an educational grant from Consumer Specialty Products Association [trade association for companies engaged in the manufacture, formulations, distribution, and sale of cleaners and disinfectants]; Kimberly-Clark. . . .David J. Weber: Honoraria from Consumer Specialty Products Association; consultation with Clorox; and educational grant from Consumer Specialty Products Association.” Of course, the ethical implications of such relationships are arguable, at least in the U.S., where the research for regulatory compliance so often must be funded by manufacturers, ideally in collaboration with “independent” organizations like universities, hospitals, and the CDC. People who are most prepared to do research on efficacy and safety regularly pass through the same set of revolving doors, and the regulatory regime maintains them.
- ¹⁵⁵ Marcus Dettenkofer *et al.*, “Does Disinfection of Environmental Surfaces Influence Nosocomial Infection Rates? A Systematic Review,” *American Journal of Infection Control* 32:2 (April, 2004), p. 84.
- ¹⁵⁶ Marcus Dettenkofer *et al.*, “Does Disinfection of Environmental Surfaces Influence Nosocomial Infection Rates? A Systematic Review,” *American Journal of Infection Control* 32:2 (April, 2004), pp. 84-89; Stephanie J. Dancer, [Floor Wars: the Battle for 'Clean' Surfaces](#), *Journal of Hospital Infection* 84:4 (August, 2013), pp. 339-340; D. Danforth *et al.*, “Nosocomial Infections on Nursing Units with Floors Cleaned with a Disinfectant Compared with Detergent,” *Journal of Hospital Infection* 10 (1987), pp. 229-235; Franz Daschner and Schuster Armin, “Disinfection and the Prevention of Infectious Disease – No Adverse Effects?” *American Journal of Infection Control* 32:4 (June, 2004), pp. 224-225; Jonathan A. Otter *et al.*, “A Request for an Alliance in the Battle for Clean and Safe Hospital Surfaces,” *Journal of Hospital Infection* 84:4 (August 2013), pp. 341-342; William A. Rutala and David J. Weber, “The Benefits of Surface Disinfection,” *American Journal of Infection Control* 32:4 (June, 2004) pp. 226-231. See also: Henning Ruden and Franz Daschner, “Should We Routinely Disinfect Floors?” *Journal of Hospital Infection* 51:4 (August, 2002), p. 309; and David Sedlak, *Water 4.0: The Past, Present, and Future of the World's Most Vital Resource* (New Haven, CT: Yale University Press, 2014), especially the chapter on “The Chlorine Dilemma” (pp. 90-111) that covers the history of the use of chlorine compounds to reduce water-borne infections. E.g., chlorine used in municipal water treatment facilities has been implicated in the production of small concentrations of compounds that are suspected carcinogens, especially when in contact with metabolites in “humic substances” (waters rich in organics). Furthermore, a shift to less chlorinated disinfectants (chloramines) reduced the associated concentration of most well-known pathogens (e.g., trihalomethane) but also introduced yet others (e.g., tiny concentrations of much more carcinogenic byproducts). Once again, the use of disinfectant entails a contestable trade-off.
- ¹⁵⁷ At lot depends on what the word “disinfectant” covers, what counts as “normal use,” and what counts as “harm.” Compare, for example, Ahmed A., Arif, George L. Delclos, and Consol Serra, [Occupational](#)

[Exposures and Asthma among Nursing Professionals](#), *Occupational and Environmental Medicine* 66:4 (April, 2009), pp. 274-278; with Caroline M Slotosch, Günter Kampf and Harald Löffler, [Effects of Disinfectants and Detergents on Skin Irritation](#), *Contact Dermatitis* 57:4 (October, 2007), pp. 235-241; or Line Kynemund Pedersen, *et al.*, [Short-term Effects of Alcohol-based Disinfectant and Detergent on Skin Irritation](#), *Contact Dermatitis* 52:2 (February, 2005), pp. 82-87. On the one hand, an analyst can confidently assert: "Allergy to disinfectants is one of the leading causes of occupational diseases for nurses and housekeeping personnel in German hospitals." Henning Ruden and Franz Daschner, "Should We Routinely Disinfect Floors?" *Journal of Hospital Infection* 51:4 (August, 2002), p. 309. Another can just as confidently counter: "All studies used for assessing hazards to health care workers from disinfectants meet only the lowest level of study design. Well-designed immunologic evaluations of randomly selected health care workers and appropriate controls have not been performed, and hence the prevalence and incidence of clinically-relevant asthma or atopic dermatitis as a result of occupational exposure to surface disinfectants is unknown. It has also been proposed that allergy to disinfectants is one of the leading causes of occupational diseases to nurses and housekeeping personnel in German hospitals. Since this statement was unreferenced, we conducted a literature review (*Medline*) from 1966 to April 2004, which provided no evidence that suggests the use of low-level disinfectants (e.g., phenolics and QACs) results in allergic symptoms in health care workers. Fourth, if biocides cause harm to the environment this would be a serious issue. However, the references cited by Daschner and Schuster and Dettenkofer and associates do not provide evidence that QACs have low biodegradability or QACs discharged by hospitals have toxic effects against microorganisms in sewage treatment plants (STPs)." William A. Rutala and David J. Weber, "The Benefits of Surface Disinfection," *American Journal of Infection Control* 32:4 (June, 2004) p. 229. See also: William A. Rutala and David J. Weber. "Should We Routinely Disinfect Floors? Reply to Professor F. Daschner," *Journal of Hospital Infection* 51:4 (August, 2002), p. 310.

¹⁵⁸ Marcus Dettenkofer and Robert C. Spencer, "Importance of Environmental Decontamination a Critical View," *Journal of Hospital Infection* 65:Supplement 2 (June, 2007), pp. 55-57.

¹⁵⁹ "No differences have been found in healthcare-associated infections rates when floors are cleaned with detergent rather than disinfectant. However, these studies have been small and of short duration and suffer from low statistical power because the outcome – healthcare-associated infections – is of low frequency. The low rate of infections makes the efficacy of an intervention statistically difficult to demonstrate. Because housekeeping surfaces are associated with the lowest risk for disease transmission, some researchers have suggested that either detergents or a disinfectant/detergent could be used." The Centers for Disease Control and Prevention (CDC), [Guideline for Disinfection and Sterilization in Healthcare Facilities, 2008](#), ed. William A Rutala, *et al.* (November, 2008), p. 30. "The choice of specific cleaning or disinfecting agents is largely a matter of judgment, guided by product label claims and instructions and government regulations." The Centers for Disease Control and Prevention (CDC), *Morbidity and Mortality Weekly Report (MMWR): Guidelines for Infection Control in Dental Health-Care Settings – 2003* 52:RR17, Appendix A: [Regulatory Framework for Disinfectants and Sterilants](#), (December 19, 2003), p. 62.

¹⁶⁰ Laura R. Hancox *et al.*, [Inclusion of Detergent in a Cleaning Regime and Effect on Microbial Load in Livestock Housing](#), *Veterinary Record* 173:7 (August 17, 2013), p. 167; Franz Allerberger *et al.*, [Routine Surface Disinfection in Health Care Facilities: Should We Do It?](#), *American Journal of Infection Control* 30:5 (August, 2002), pp. 319, 318.

¹⁶¹ "The routine use of disinfectants to clean hospital floors and other surfaces is controversial in relation to nosocomial infections. The practice varies nationally. In England, detergent alone is used widely, while in France, Switzerland and the USA, the use of a detergent/ disinfectant is more common. At the University Hospitals of Geneva (HUG), Switzerland, we routinely use a detergent/disinfectant to clean floors and furniture. In a period of cost containment, care of the environment, and the possible selective pressure exerted on bacteria to become resistant to antibiotics by exposing them to disinfectants we prospectively evaluated the necessity of daily disinfection of surfaces not contaminated by biological fluids and of isolation rooms. . . . A total of 1117 patients was studied and we observed no change in the incidence of nosocomial infections during the four months of the trial. In conclusion, uncontrolled routine disinfection of environmental surfaces does not necessarily make it safe for the patient and could seed

the environment with potential pathogens.” Sasi Dharan *et al.*, Routine Disinfection of Patients' Environmental Surfaces: Myth or Reality?, *Journal of Hospital Infection* 42:2 (June, 1999), pp. 113-114.

¹⁶² Note the difference in risks and in the importance of remediation for direct versus indirect contamination. “As this article shows, a contaminated environment contributes considerably to the transmission of FMDV, and vaccination of cattle 1 week prior to inoculation with the virus does confer protective immunity against FMDV infection. . . . FMDV transmission may not occur, however, when animals are separated by fences or wooden walls [for pigs and calves]. . . indicating that either exposure to virus secreting and/or excreting animals or [direct] exposure to virus contaminated surfaces is important for the occurrence of transmission.” Hence, for this study, technicians only changed coveralls and gloves when moving between experimental groups. Carla Bravo de Rueda, *et al.*, [Quantification of Transmission of Foot-And-Mouth Disease Virus Caused by an Environment Contaminated with Secretions and Excretions from Infected Calves](#), *Veterinary Research* 46:1 (April, 2015), pp. 2-10.

¹⁶³ For example: “The precise effects under field conditions of most individual interventions applied to control and prevent avian influenza have not been established or subjected to critical review, often because a number of measures are applied simultaneously without controls. In most cases, the combination of measures used results in control or elimination of the virus although there are some countries where this has not been the case. In others, especially those with low poultry density, it is not clear whether the link between the adoption of a set of measures and the subsequent control of the disease is causative. . . . In other words, a ‘one size fits all’ approach to control and the prevention of avian influenza does not exist, and programmes based on single measures are rarely successful in preventing or controlling infection. . . . Biosecurity measures introduced to farms or in markets to reduce the likelihood of introduction of avian influenza viruses can markedly reduce the risk of infection of poultry and provide a return on investment. A key constraint is that the measures must be cost-effective for the production system and producer. . . . The measures proposed for small-scale poultry producers must be practical and affordable, focusing in particular on behavioural change and simple, cost-effective measures.” Leslie Sims, [Intervention Strategies to Reduce the Risk of Zoonotic Infection with Avian Influenza viruses: Scientific Basis, Challenges and Knowledge Gaps](#), *Influenza and Other Respiratory Viruses* 7:2 (September, 2013), pp. 15-16 and 20-21.

¹⁶⁴ Thomas J. Hagenaars *et al.*, [Estimation of Foot and Mouth Disease Transmission Parameters, Using Outbreak Data and Transmission Experiments](#), *Revue Scientifique et Technique* (OIE) 30: 2 (2011), p. 474. The most recent and comprehensive review of the reviews is USDA-APHIS and University of Minnesota Center for Animal Health and Food Safety, Timothy J. Goldsmith, Principal Investigator, *Risk Assessment for the Transmission of Foot-and-Mouth Disease via the Transport of Raw Milk Into, Within, and Outside of a Control Area during an Outbreak* (May, 2013), which heavily relies on and excerpts from three prior publications (“three studies found that provided up-to-date and concise information on what is known and unknown about involvement of milk tankers, people, and vehicles in the spread of disease, and that was applicable to this risk assessment”): Nick Honhold, Tony Taucher, and Nick Taylor, “The Involvement of Milk Tankers in the Spread of Foot and Mouth Disease in Cumbria, 2001,” The University of Reading (2004), Appendix 5 in [Detailed Investigation of the Methods and Characteristics of Spread of FMD in Specific Geographic Clusters and the Effects of Control Measures during the 2001 Epidemic](#), Final Project Report to DEFRA (2005); Sandra F. Amass *et al.*, [Procedures for Preventing the Transmission of Foot-and-Mouth Disease Virus to Pigs and Sheep by Personnel in Contact with Infected Pigs](#), *Veterinary Record* 153:5 (August, 2003), pp. 137-140; and Johanne Ellis-Iversen, *et al.*, [Risk Factors for Transmission of Foot-and-Mouth Disease during an Outbreak in Southern England](#), *Veterinary Record* 168:5 (February 5, 2011), p. 128. Note that similar ambiguity – a combination of poor evidence and persistent faith in biosecurity – permeates analysis of the current HPAI outbreak in the Midwest. After months of epidemiological investigation, processing thousands of samples, U.S. authorities report: “APHIS concludes that at present, there is not substantial or significant enough evidence to point to a specific pathway or pathways for the current spread of the virus. . . . APHIS will continue to investigate how the HPAI virus is introduced and spread and will provide updated results regularly. Comprehensive and stringent biosecurity practices will remain crucial to reducing the risk of HPAI infection.” USDA-APHIS-Veterinary Service, [Epidemiologic and Other Analyses of HPAI-Affected Poultry Flocks: June 15, 2015 Report](#) (June 16, 2015), p. 1.

-
- ¹⁶⁵ Jane C. Gibbens *et al.*, [Descriptive Epidemiology of the 2001 Foot-and-Mouth Disease Epidemic in Great Britain: The First Five Months](#), *Veterinary Record* 149:24 (December 15, 2001), pp. 729-743; USDA-APHIS and University of Minnesota Center for Animal Health and Food Safety, Timothy J. Goldsmith, Principal Investigator, *Risk Assessment for the Transmission of Foot-and-Mouth Disease via the Transport of Raw Milk Into, Within, and Outside of a Control Area during an Outbreak* (May, 2013), pp. 21-24.
- ¹⁶⁶ Several studies of the recent PED outbreak suggest that the precautions that failed were of the “thoroughness” variety, attributable to neglect of standard precautions at the top of most lists, like minimizing drivers’ foot traffic in livestock facilities and washing boots. C&D details or paperwork were not particularly relevant. See, for example: James F. Lowe *et al.*, [Role of Transportation in Spread of Porcine Epidemic Diarrhea Virus Infection, United States](#), *Emerging Infectious Disease* 20:5 (May, 2014), pp. 872-874; Aaron J. Lower, [PED and PRRS ARC&E U.S.A. Lessons Learned](#), presentation slides (October 10, 2013), slides 26 and 32.
- ¹⁶⁷ Connor, Joseph *et al.*, [Truck Wash Biosecurity Critical](#), *National Hog Farmer* (December 12, 2014); James F. Lowe *et al.*, [Role of Transportation in Spread of Porcine Epidemic Diarrhea Virus Infection, United States](#), *Emerging Infectious Disease* 20:5 (May, 2014), pp. 872-874; Aaron J. Lower, [PED and PRRS ARC&E U.S.A. Lessons Learned](#), presentation slides (October 10, 2013); Sureemas Nitikanjana, [Potential Alternatives to Reduce Porcine Epidemic Diarrhea Virus \(PEDV\) Contamination in Feed Ingredients](#) (February 26, 2014); Paul R. Thomas *et al.*, [Evaluation of Time and Temperature Sufficient to Inactivate Porcine Epidemic Diarrhea Virus in Swine Feces on Metal Surfaces](#), *Journal of Swine Health and Production* 23:2 (March and April, 2015), pp. 84-90; Paul R. Thomas *et al.*, [Methods for Inactivating PEDV in Hog Trailers](#), *Iowa State University Animal Industry Report 2015*, AS 661, ASL R3028 (January, 2015).
- ¹⁶⁸ Note, for example, the slippage between a cited new USDA-AHIS report (including a frank admission of uncertainty) and the message emphasized in the press, with “poor biosecurity” dominating the headline: “While scientists are confident wild birds were responsible for introducing HPAI into commercial poultry, ‘it appears the virus was spreading in other ways. Although APHIS cannot at present point to a single statistically significant pathway for the current spread of HPAI, a likely cause of some virus transmission is insufficient application of recommended biosecurity practices,’ said the agency.
In particular it points to:
- Sharing of equipment between infected and non-infected farms
 - Employees moving between infected and non-infected farms
 - Lack of cleaning and disinfection of vehicles moving between farms
 - Reports of rodents or small wild birds inside the poultry houses
- Analysis by APHIS also found that air samples collected outside infected poultry houses contained virus particles, indicating that the virus could be transmitted by air.” Philip Clarke, [Poor Biosecurity in U.S. ‘Has Helped Spread Bird Flu’](#), *World Poultry* (June 17, 2015).
- ¹⁶⁹ U.S. Department of Homeland Security, [S&T, Canada, USDA Partner to Develop a Car Wash that Could Protect Food Supply](#) (April 20, 2015). This excerpt refers to a joint field trial of on-farm vehicle washing, applying standards very much like those stipulated in the SMS BPS. The trial failed in that contaminants above the EPA standard remained on vehicles even after full cleaning and disinfection in the prescribed methods by trained applicators with oversight by international experts. Lori Miller, webinars for the Secure Milk Supply working group (January 15, 2013 and July 21, 2014) and Elizabeth Rohonczy and Lori Miller, personal correspondence, 2013-2015.
- ¹⁷⁰ USDA-APHIS and University of Minnesota Center for Animal Health and Food Safety, Timothy J. Goldsmith, Principal Investigator, *Risk Assessment for the Transmission of Foot-and-Mouth Disease via the Transport of Raw Milk Into, Within, and Outside of a Control Area during an Outbreak* (May, 2013). See also: Secure Milk Supply Plan, [Secure Milk Supply \(SMS\) Plan for a Foot-and-Mouth Disease \(FMD\) Outbreak: Baseline Risk Assessment for the Movement of Raw Milk to Processing: Results Summary](#) (September 2012); Timothy J. Goldsmith, [Proactive Risk Assessment to Support Managed Movement of Livestock and Poultry](#), Presentation at the 2014 Annual Meeting of the USAHA, Kansas City, MO (October 18, 2014); and Elizabeth Wagstrom *et al.*, [The Role of Proactive Risk Assessments in Ensuring Business](#)

[Continuity in the Swine Industry during an FMD Outbreak](#), *Safe Pork 2011*, Proceedings of Ninth International Conference on the Epidemiology and Control of Biological, Chemical and Physical Hazards in Pigs and Pork, Portland, Maine (August 5-7, 2011), pp. 392-394.

¹⁷¹ “Unlike in human medicine, real-time case-control studies are rare during animal health epidemics. The present study provided an insight into risk factors during an outbreak and has generated possible recommendations for farmers. The authors hope that similar studies will be carried out in the future during outbreaks to support the present findings and enhance the certainty around the conclusions. . . . The risk associated with a lack of biosecurity was reflected in some of the identified risk factors. **Visitor car parks away from livestock areas were more common on control farms [uninfected] than case farms [infected] and appeared to be more protective against infection than wheel washing, which is a commonly recommended practice** [emphasis added]. Moving curious young animals away from perimeter fields and avoiding outdoor calvings may also reduce the rate of transmission in a population. Slower development of an outbreak may allow more complete identification of infected farms and culling of infected animals in a given time frame, and thereby control the size of the outbreak.” Johanne Ellis-Iversen, *et al.*, [Risk Factors for Transmission of Foot-and-Mouth Disease during an Outbreak in Southern England](#), *Veterinary Record* 168:5 (February 5, 2011), p. 128. Note that this study uses composite scoring of many biosecurity barriers and practices rather than a pass/fail list.

¹⁷² “The matched case control study [of 124 infected premises in the 2001 outbreak of FMD in the U.K.] compared the numbers of risk visits (received over equal time periods) between farms which became infected (cases) and paired farms which did not (controls that remained standing until the end of the epidemic), matched by location and herd size. There was no evidence that cases received significantly more risk visits than controls. All of the statistical analyses yield high p-values (certainly greater than 0.1) indicating no significant difference in the degree of exposure to risk visits by milk tankers between the cases and the controls. In addition, there was no evidence that some milk tankers were at greater risk of transmitting the disease than others. The hypothesis that increased numbers of visits from potentially contaminated milk tankers was associated directly with the likelihood of disease has not been proven. . . . Another analysis carried out within this project (Appendix 5) has shown that increased risk of infection among dairy farms was not strongly associated with having been exposed to visits from milk tankers that had recently been on infected farms. Whilst these visits can be a mechanism for disease spread, infection was not a predictable consequence of exposure to such visits, therefore the tracing of such events could not reliably be used as a criterion for classification as a DC for pre-emptive culling.” Nick, Honhold, Tony Taucher, and Nick Taylor, “The Involvement of Milk Tankers in the Spread of Foot and Mouth Disease in Cumbria, 2001,” The University of Reading (2004), Appendix 5 in [Detailed Investigation of the Methods and Characteristics of Spread of FMD in Specific Geographic Clusters and the Effects of Control Measures during the 2001 Epidemic](#), Final Project Report to DEFRA (2005), pp.3, 20. See also: Nick Honhold, [The Impact of Farm Gate Biosecurity on the Transmission of FMD in UK in 2001](#), International Control of Foot-And-Mouth Disease: Tools, Trends and Perspectives, 2006 Session of the Research Group of the Standing Technical Committee of the European Commission for the Control of Foot-and-Mouth Disease (EuFMD), Paphos, Cyprus (October 16-20, 2006), Appendix 3, pp. 26-34; Nick Honhold Tony Taucher, and Nick Taylor, [The Involvement of Milk Tankers in the Spread of Foot and Mouth Disease in Cumbria, 2001](#), Report for Veterinary Science Directorate (October 2004), and *International Symposium on Veterinary Epidemiology and Economics Proceedings 11: Proceedings of the 11th Symposium of the International Society for Veterinary Epidemiology and Economics (ISVEE)*, Cairns, Australia, Theme 6 - Global Response and Emerging Diseases: Foot and Mouth Disease Session, (August 2006), p. 396; and Nick Honhold *et al.* [Control of Foot-and-Mouth Disease](#), *Veterinary Record* 168:20 (May, 2011), pp. 541-542.

¹⁷³ “The outbreak of FMD in Cumbria is regarded as having been severe, to have spread rapidly initially and to have had a prolonged [Epidemic Curve] tail. The present paper suggests that controlling such an outbreak in a shorter period needs a combination of a shortened time from first lesion to slaughter and biosecurity that is capable of preventing 70% of fomite transmission.” An Epidemic Curve plots the numbers of incident cases in an outbreak over time. So, outbreaks that linger – with hot spots that smolder after the blazes succumb to control – have “a long tail.” Estimated Dissemination Rate (EDR) is the ratio of the number of premises first infected in one week as compared to the prior week. Nick Honhold, [The Impact of Farm Gate Biosecurity on the Transmission of FMD in UK in 2001](#), International Control of Foot-

And-Mouth Disease: Tools, Trends and Perspectives, 2006 Session of the Research Group of the Standing Technical Committee of the European Commission for the Control of Foot-and-Mouth Disease (EuFMD), Paphos, Cyprus (October 16-20, 2006), Appendix 3, pp. 29-33. See also: Nick Honhold *et al.* [Control of Foot-and-Mouth Disease](#), *Veterinary Record* 168:20 (May, 2011), pp. 541-542.

¹⁷⁴ “Estimates of the probability of indirect transmission [e.g., trucks spreading disease] and achievable movement controls are uncertain parameters, based solely on USDA subject matter expert opinion. Model outputs are quite sensitive to these parameters and an improved knowledge of the efficacy of biosecurity practices and the ability to achieve movement controls to limit direct and indirect transmission are necessary for more focused planning of optimal control efforts.” Sara W., McReynolds *et al.*, [Modeling the Impact of Vaccination Control Strategies of a Foot and Mouth Disease Outbreak in the Central United States](#), *Preventive Veterinary Medicine* 117:3-4 (December, 2014), p. 501.

¹⁷⁵ Naomi Oreskes, *Merchants of Doubt: How a Handful of Scientists Obscured the Truth on Issues from Tobacco Smoke to Global Warming* (New York: Bloomsbury Press, 2010).

¹⁷⁶ “Readiness Ratings **in the region** [emphasis added] do not significantly vary by farm size. In general, large and small operations are equally capable of achieving a high (or low) Rating. So, a reliance on Ratings for issuing Permits should not be expected to favor one size of farm over another.” A 2014 analysis of “Size of Dairy Herds in New England by the Farm’s Readiness Rating” yields a Pearson Correlation Coefficient (r) of -0.017 and a Coefficient of Determination (r²) of 0.0003. Richard P. Horwitz, [Readiness of New England Dairy Farms for SMS: A Snapshot, 2014](#) (August 1, 2014), p. 6. See also Richard P. Horwitz, [New England as a Jurisdiction for Supporting Continuity of Dairy Operations: A Reassessment](#) (December 30, 2013) and [Foot-And-Mouth Disease \(FMD\) as a Hazard for New England Dairies](#) (June 30, 2011), pp. 25-58.

¹⁷⁷ Lessons learned from the most recent HPAI outbreak include: “Movement control and permit processes will change over time depending on situational awareness and operational capabilities.” Even that advice appears under a warning, in red bold type: “Please note: These procedures may be revised as the situation develops.” USDA, [HPAI Outbreak 2014-2015 Movement Control](#) Version 2 (May 11, 2015), p. 1.

¹⁷⁸ Participants in the most recent national HPAI-response planning workshop found: “Biosecurity – Gaps and Solutions: During the workshop, a number of gaps and challenges were identified relating to biosecurity. While everyone understands the importance of biosecurity, it is difficult to get biosecurity ‘right’ all the time. Maintaining a culture of strict biosecurity means everyone on the premises – from the grower to the integrator to visitors – must follow standard biosecurity practices that are sometimes inconvenient for individuals and costly for the producer. There is no practical way to oversee all personnel at all times, which may result in lapses, even in places where workers are closely scrutinized. Also, because there is no one-size-fits-all solution (recipe) for good biosecurity, producers and growers must adopt the basic principles of biosecurity to meet their particular facilities and production practices.” Among the challenges that USDA-APHIS identified to fill the gap: “Consult with industry and State animal health officials to prioritize those biosecurity practices that can be developed into sound standard operating procedures; and Collaborate with industry and State officials in developing a model biosecurity auditing system that is clear, fair, and practical.” USDA-APHIS, [Highly Pathogenic Avian Influenza Fall Planning Workshop: Summary and Next Steps](#), Riverdale, MD (June 30 and July 1, 2015), pp. 2-3. This document is intended to contribute to that effort.