



NEURAL NETWORKS APPLICATION FOR MECHANICAL PARAMETERS IDENTIFICATION OF ASYNCHRONOUS MOTOR

D. Balara, J. Timko*, J. Žilková*, M. Lešo**

Abstract: A method for identification of mechanical parameters of an asynchronous motor is presented in this paper. The identification method is based on the use of our knowledge of the system. This paper clarifies the method by using the example identifying of mechanical parameters of the three-phase squirrel-cage asynchronous motor. A model of mechanical subsystem of the motor is presented as well as results of simulation. The special neural network is used as an identification model and its adaptation is based on the gradient descent method. The parameters of mechanical subsystem are derived from the values of synaptic weights of the neural identification model after its adaptation. Deviation of identified mechanical parameters in the case of moment inertia was up to 0.03 % and in the case of load torque was 1.45 % of real values.

Key words: *neural network, identification, electric drive*

Received: June 14, 2016

DOI: 10.14311/NNW.2017.27.013

Revised and accepted: June 11, 2017

1. Introduction

To ensure a high quality control of nonlinear dynamic systems, precise knowledge of parameters is required. In the system identification many different approaches can be used depending on the prior information available. The solution to the question of identification of parameters of non-linear dynamic systems and of electrical drives as well, the use of conventional identification methods necessitates complicated and time consuming calculations and they can be expensive to perform special preparation of the system for the measurement [12, 14]. What more, the conventional methods used for the identification of systems parameters are based on a number of assumptions that are not valid under all operating conditions. In recent years, the research in the field of electrical drives is has been also focused on the application of different methods of artificial intelligence [1, 3–7, 13, 15, 17] as the theory of artificial

*Dušan Balara; Jaroslav Timko; Jaroslava Žilková; Martin Lešo – Corresponding author; Technical University of Košice, Department of Electrical Engineering and Mechatronics, Letná 9, 042 00 Košice, Slovak Republic, E-mail: balarad@vadium.sk, jaroslav.timko@tuke.sk, jaroslava.zilkova@tuke.sk, martin.leso@tuke.sk

neural networks (ANN) and the fuzzy sets theory or the genetic algorithms theory. The theory of fuzzy sets is most often used for systems control [4, 7, 15] and the genetic algorithms are often used for optimization tasks [5, 7] in the field of electric drives. The artificial neural networks (ANNs) are most commonly used for solving tasks as: approximation, association, classification, control or prediction. ANNs can work in parallel and thus shorter computation time can be achieved. Moreover, they can be used to identify and control the non-linear dynamic systems because they can approximate a wide range of nonlinear functions to any desired degree of accuracy [9, 10]. In the field of electric drives ANNs can be used for electric drives control [4, 7, 13, 15], estimation quantities of electric drives [4, 13, 15], especially angular speed, and also for identification of electric drives parameters [1, 13, 17].

Used at designing the neural identification structure can be of two differing approaches:

- When using neural network with a larger number of neurons approximated is the estimated quantity or parameter, based on simply measurable system quantities [13].
- The neural structure is determined by using the analogy of structure of a known system mathematical model, and thus the neural network parametric structure is created, while the network parameters containing information on the system parameters are being looked for [1].

In this paper, a special neural network is presented as an identification model and parameters of mechanical subsystem of a squirrel-cage asynchronous motor are identified by using the single neuron with adaptation rule based on gradient descent algorithm widely used in neural networks training [2]. The proposed identification model identifies the following parameters of mechanical subsystem of an asynchronous motor: moment of inertia J , constant passive load torque m_L and steepness of linear friction characteristic b . Magnetic fluxes [1] of the asynchronous motor were supposed to be derived from an observer and stator voltages, stator currents and mechanical speed are supposed to be measured. The proposed identification neural model was tested by simulation, including the identified motor.

2. Model of an asynchronous motor

We considered was a two-pole representation of a squirrel-cage asynchronous motor model transformed into x, y reference frame rotating with synchronous speed given by Eqs. (1)–(9). The transformation of the three-phases stator voltages into stationary α, β reference frame (1) by [8] is shown in Fig. 1.

$$u_{\alpha 1} = \frac{1}{3}(2u_a - u_b - u_c) \text{ and } u_{\beta 1} = \frac{1}{\sqrt{3}}(u_b - u_c). \quad (1)$$

Fig. 2 shows transformation of two-phases stator voltages stationary reference frame α, β into x, y reference frame rotating with synchronous speed by Eq. (2) [8]:

$$u_{x1} = \cos \vartheta_S \cdot u_{\alpha} + \sin \vartheta_S \cdot u_{\beta}, \quad (2)$$

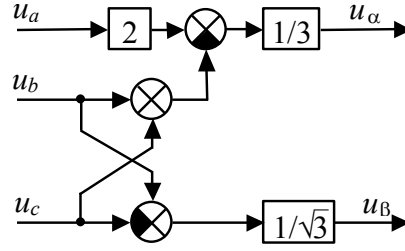

Fig. 1 Transformation of phase voltages into α, β frame of reference.

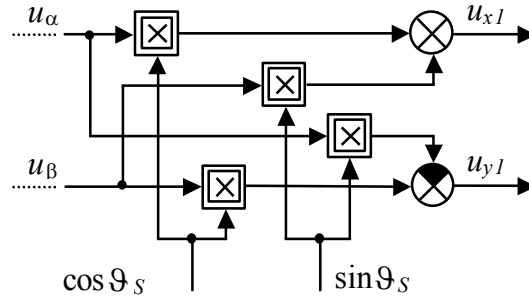

Fig. 2 Transformation of stator voltages into x, y frame of reference.

$$u_{y1} = -\sin \vartheta_S \cdot u_{\alpha} + \cos \vartheta_S \cdot u_{\beta} \text{ and } \frac{d\vartheta_S}{dt} = \omega_S.$$

The two phase electrical equations of a squirrel-cage asynchronous motor in α, β reference frame transformed into x, y reference frame rotating with synchronous speed shown in Eqs. (3)–(9) are given by [13]:

$$u_{x1} = R_S i_{x1} + \frac{d\psi_{x1}}{dt} - \omega_s \psi_{y1}, \tag{3}$$

$$u_{y1} = R_S i_{y1} + \frac{d\psi_{y1}}{dt} + \omega_s \psi_{x1},$$

$$u_{x2} = R_R i_{x2} + \frac{d\psi_{x2}}{dt} - (\omega_s - \omega_{\text{mech}}) \cdot \psi_{y2},$$

$$u_{y2} = R_R i_{y2} + \frac{d\psi_{y2}}{dt} + (\omega_s - \omega_{\text{mech}}) \cdot \psi_{x2},$$

$$i_{x1} = \frac{1}{L_s \sigma} \left(\psi_{x1} - \frac{1}{\nu_R} \psi_{x2} \right), i_{y1} = \frac{1}{L_s \sigma} \left(\psi_{y1} - \frac{1}{\nu_R} \psi_{y2} \right), \tag{4}$$

$$i_{x2} = \frac{1}{L_s \sigma} \left(\psi_{x2} - \frac{1}{\nu_S} \psi_{x1} \right), i_{y2} = \frac{1}{L_s \sigma} \left(\psi_{y2} - \frac{1}{\nu_S} \psi_{y1} \right),$$

$$\frac{d\psi_{x1}}{dt} = u_{x1} - R_S i_{x1} + \omega_S \psi_{y1}, \tag{5}$$

$$\frac{d\psi_{y1}}{dt} = u_{y1} - R_S i_{y1} - \omega_S \psi_{x1},$$

$$\frac{d\psi_{x2}}{dt} = u_{x2} - R_R i_{x2} + (\omega_S - \omega_{\text{mech}}) \psi_{y2},$$

$$\frac{d\psi_{y2}}{dt} = u_{y2} - R_R i_{y2} - (\omega_S - \omega_{\text{mech}}) \psi_{x2},$$

where for a squirrel-cage asynchronous motor is $u_{x2} = u_{y2} = 0$ and

$$\omega_S = \frac{2\pi f}{p_p}, \sigma = 1 - \frac{L_h^2}{L_S L_R}, \nu_S = \frac{L_S}{L_h}, \nu_R = \frac{L_R}{L_h}. \quad (6)$$

i_1, i_2	stator and rotor currents
u_1, u_2	stator and rotor voltages
ψ_1, ψ_2	stator and rotor magnetic fluxes
p_p	number of the pole pairs
ω_s	synchronous angular speed
ω_{mech}	mechanical angular speed
m, m_L, m_f	motor, load and friction torque
L_S, L_R, L_h	leakage inductances of stator and rotor, mutual inductance
R_S, R_R	stator and rotor resistance
J	moment of inertia

Tab. I Used symbols.

Discrete models of stator and rotor according to Eqs. (3)–(6) with use of rectangular method of numerical integration are presented by models in Fig. 3 and Fig. 4.

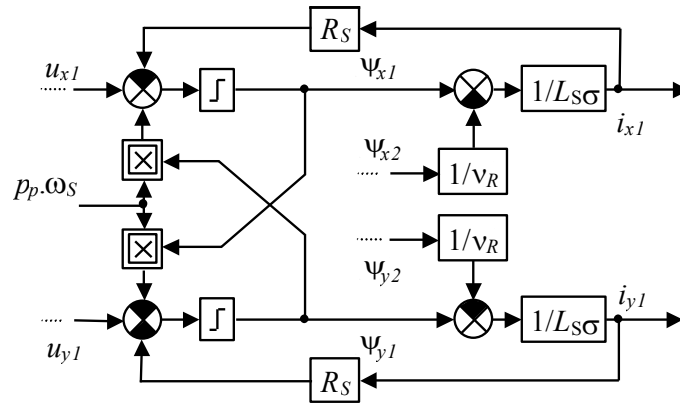

Fig. 3 Model of stator.

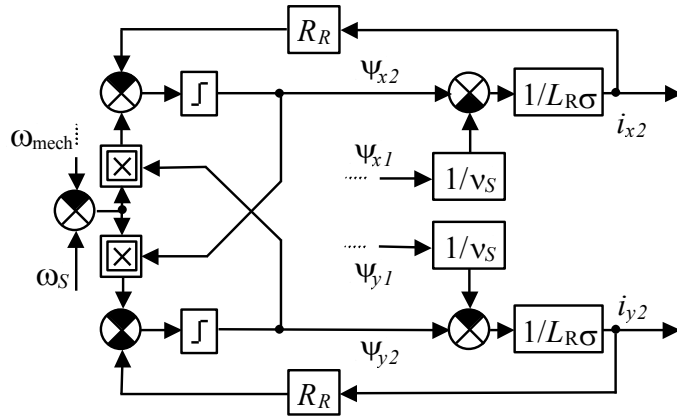

Fig. 4 Model of rotor.

The mechanical equation for the motor can be expressed by [13]:

$$m = \frac{3}{2} p_p (\psi_{x1} i_{y1} - \psi_{y1} i_{x1}), \tag{7}$$

$$m - m_L \cdot \text{sgn}(\omega_{\text{mech}}) - m_f = J \frac{d\omega_{\text{mech}}}{dt}, \tag{8}$$

where friction torque is given by:

$$m_f = b \cdot \omega_{\text{mech}}, \tag{9}$$

where b denotes the slope of the linear component of viscous friction. Constant passive load m_L may include Coulomb friction. Fig. 5 shows model of the mechanical subsystem by Eqs. (7)–(9), where the symbol \int denotes numerical integrator and its discrete model is represented in Fig. 6.

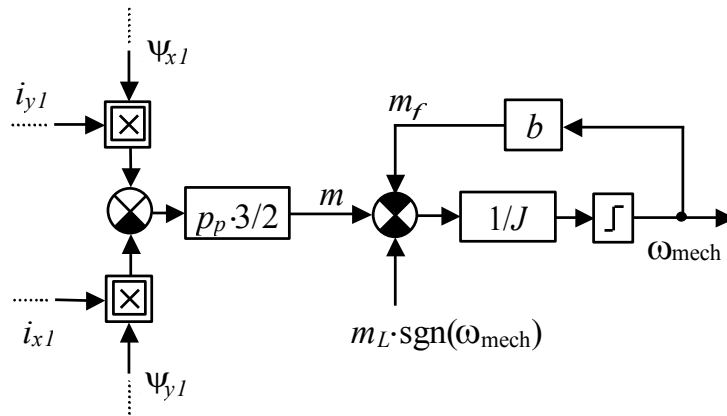

Fig. 5 Model of mechanical subsystem.

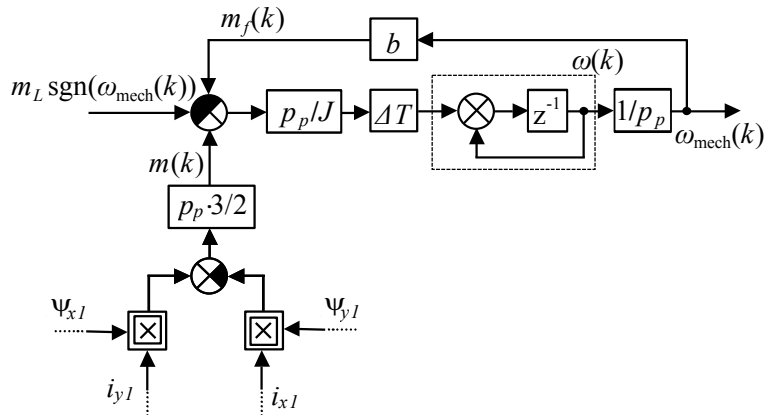

Fig. 6 Discrete model of the mechanical subsystem.

3. Design of neural identifier

The neural identification structure shown on Fig. 7 that is based on easily measurable quantities, i.e. stator current i_1 , angular speed ω_{mech} , and stator voltage u_1 for obtaining the values of stator flux, may be analogous to the discrete model of the mechanical subsystem in Fig. 6.

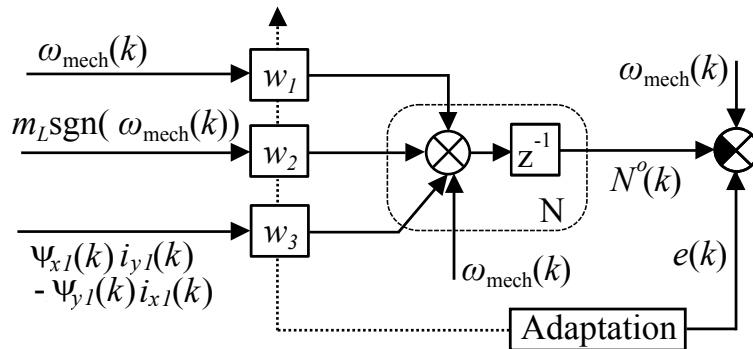

Fig. 7 Neural identification model of mechanical subsystem of an asynchronous motor.

The output of the neural identification model (Fig. 7):

$$N^o = o = \omega_{\text{mech}}^* \tag{10}$$

where symbol * denotes the output of the identification model, may be analogous to expression Eq. (8):

$$o = \frac{3 p_p \Delta T}{2 J} (\psi_{x1} i_{y1} - \psi_{y1} i_{x1}) + \left(-\frac{b \Delta T}{J} \omega_{\text{mech}} \right) + \left(-\frac{m_L \Delta T}{J} \text{sgn}(\omega_{\text{mech}}) \right). \tag{11}$$

The network weights w_1 , w_2 and w_3 (Fig. 7) are elected so that they corresponded with the asynchronous motor mechanical parameters Eq. (11) as below:

$$w_1 \approx \frac{\frac{3}{2}p_p \Delta T}{J}, w_2 \approx -\frac{b \Delta T}{J}, w_3 \approx -\frac{m_L \Delta T}{J}. \quad (12)$$

In the case of ideal adaptation of identification model weights we find the values of mechanical parameters from Eq. (12).

4. Rules of adaption

When using stator currents and stator magnetic fluxes as inputs and mechanical angular speed as a desired output, the identification model adapts its weights using the well known gradient descent method [2]. The identification model with structure identical to mechanical subsystem is represented by linear neuron N on Fig. 7. The neural model output $o = N^o$ is compared with the desired measured angular speed value and deviation e serves for adaptation of the neuron weights so that the neural model output agreed with the measured value of angular speed.

Let E be the cost function:

$$E = \frac{1}{2}e^2, \quad (13)$$

where e is deviation between the desired and actual neuron output. According to the gradient descent algorithm the change of every weight should be performed in the direction opposite to the particular component of gradient of E :

$$\Delta w_n = -\eta_{cn} \frac{\partial E}{\partial w_n}, \frac{\partial E}{\partial w_n} = -e \cdot \frac{\partial o}{\partial w_n}, \frac{\partial o}{\partial w_n} = i_n, \quad (14)$$

where i_n is n -th input of the neuron and η_{cn} is learning rate. From Eq. (14) follows:

$$\Delta w_n(k) = \eta_n \cdot e(k) \cdot i_n(k), \quad (15)$$

where $\eta_n = \eta_{cn} \cdot \Delta T$. The adaptation rule must be modified to take into account the time delay member:

$$\Delta w_n(k) = \eta_n \cdot e(k) \cdot i_n(k-1). \quad (16)$$

After the adaptation, when the behaviour of the model is almost identical to the behaviour of the motor, the identified parameters can be derived from particular weights of neuron N with use of Eq. (11). We obtain parameter J from weight w_1 , b from w_2 and m_L from weight w_3 .

5. Identification of parameters

The parameters of a squirrel-cage asynchronous motor used in the simulation were: $m_L = 5 \text{ Nm}$, $b = 0.01 \text{ Nms}$, $U = 190 \text{ V}$, $f = 50 \text{ Hz}$, $R_S = 0.181 \Omega$, $R_R = 0.161 \Omega$, $J = 0.11 \text{ kgm}^2$, $p_p = 2$, $L_S = 0.06583 \text{ H}$, $L_R = 0.06583 \text{ H}$, $L_h = 0.064 \text{ H}$.

Phase voltages of the stator u_a , u_b and u_c had a form of periodical 6 step wave with the amplitude of 190 V (Fig. 8).

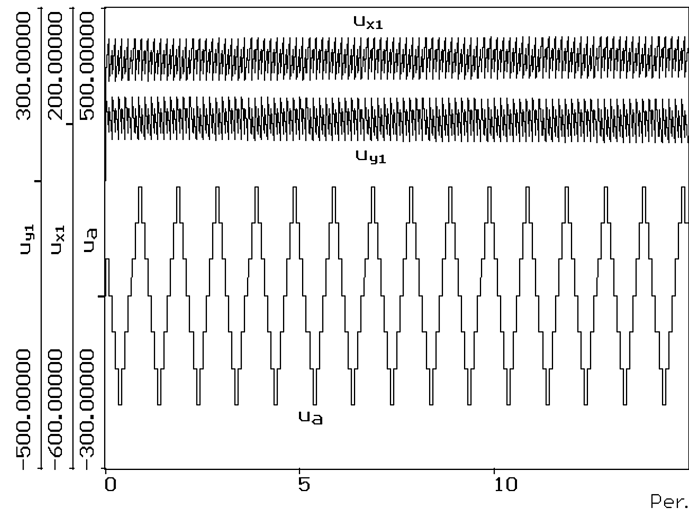

Fig. 8 Phase voltage u_a and two-pole representation voltages transformed into xy frame.

The speed of the motor was reversed every 75 periods (Fig. 9, Fig. 11) of stator phase voltage in order to provide richer training signals for the identifier, which is especially essential for identification of load torque m_L . Initial values of all weights of the neuron model were equal to zero. The values of learning rates were not chosen the same in adaptation process: $\eta_1 = 0.000001$, $\eta_2 = 0.00000001$, $\eta_3 = 0.00001$.

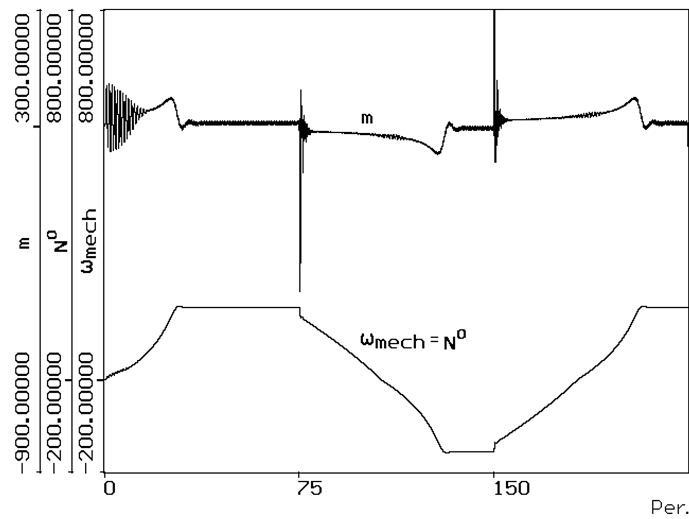

Fig. 9 Courses of torque and mechanical speed of the motor.

Although the output N^o of the identification model converged very fast to required signal (Fig. 10), the convergence of individual weight values that is shown in Fig. 11, was much slower.

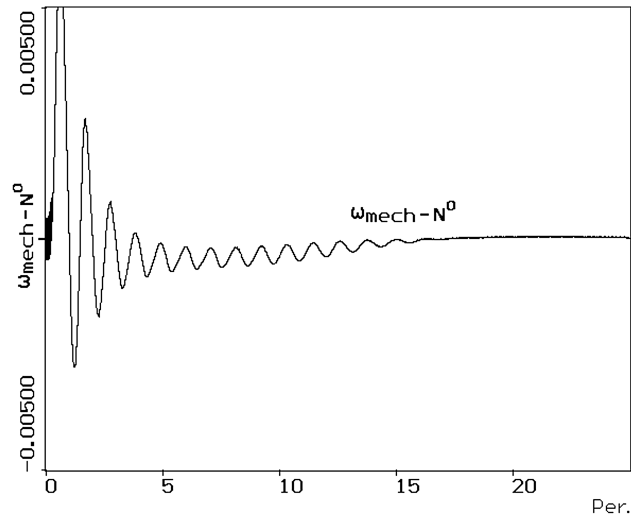

Fig. 10 Deviation between mechanical speed of the motor and output of the identification model.

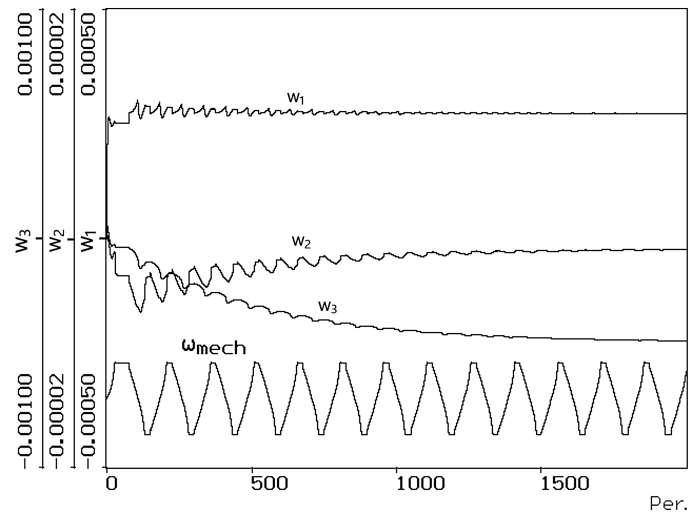

Fig. 11 Adaptation of weights and course of reference mechanical speed of the motor.

The difference between the real value of particular weights and their identified value during adaptation process is shown in Fig. 12.

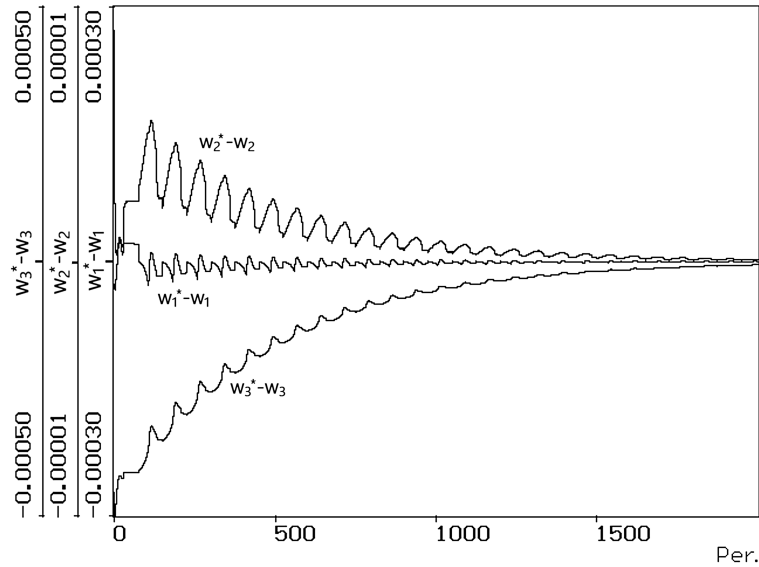

Fig. 12 Deviation between target and actual values of weights.

Tab. II shows the comparison of parameters derived from weights values of identification model after 13 repetitions of training set (Fig. 11) according to Eq. (12) and their real values.

Parameter	Identified value	Real Value	Derivation
J	0.10997 kgm ²	0.11 kgm ²	0.0273 %
b	0.01080 Nms	0.01 Nms	8.0 %
m_L	4.9277 Nm	5 Nm	1.446 %

Tab. II Identified mechanical parameters of the motor.

Neglecting the exponential component of friction may cause a significantly higher deviation of identified steepness of the friction characteristic b . The deviation of identified and real load torque m_L is caused by input signal for its identification, which was a sign of rotary speed of the motor. This signal was infrequently changed in comparison with other input signals, therefore, it only had a little information for identification of the parameter.

6. Conclusion

In this paper the neural identification method of nonlinear dynamic systems is suggested. The proposed identification method is based on the use of our knowledge of the identified system. Very simple neural adaptive structure, analogous to the model of system was used as the neural identifier. In the identification model simple measured signals of the system are used as inputs to the model. Parameters of the system were derived from the values of synaptic weights of the neural model after its adaptation. The gradient descent algorithm was used for adaptation of parameters of the neural network.

The identification method was used as an example of the neural networks applications for a squirrel-cage asynchronous motor. Our aim was to identify mechanical parameters of an asynchronous motor like moment of inertia J , constant passive load moment m_L and steepness of linear friction characteristic b . The identification method was completely computer simulated, including the identified motor. The achieved identified values of parameters of the system are very close to their real values.

The identification method should be successfully applied to identify the parameters of many other nonlinear dynamic systems, especially if we know their structures.

Acknowledgement

The authors wish to thank the project VEGA 1/0464/15 for its support.

References

- [1] BALARA D., TIMKO J., ŽILKOVÁ J. Application of neural network model for parameters identification of non-linear dynamic system. *Neural Network World*. 2013, 23(2) pp. 103–116, doi: [10.14311/NNW.2013.23.008](https://doi.org/10.14311/NNW.2013.23.008).
- [2] BALDI P.: Gradient Descent Learning Algorithm Overview: A General dynamical systems perspective. *IEEE Transaction on Neural Networks*. 1995, 6(1) pp. 182–195, doi: [10.1109/72.363438](https://doi.org/10.1109/72.363438).
- [3] BORBEĽ M., TIMKO J., ŽILKOVÁ J. Neural speed estimator for the induction motor drive. *Electrotechnica et Informatica*. 2002, 2(4) pp. 27–30.
- [4] BOSE B.K. Expert system, fuzzy logic, and neural network applications in power electronics and motion control. *Proceedings of the IEEE*. 1994, 82(8) pp. 1303–1323, doi: [10.1109/5.301690](https://doi.org/10.1109/5.301690).
- [5] BRANDŠTETTER P., DOBROVSKÝ M., KUCHARŔ M. Implementation of Genetic Algorithm in Control Structure of Induction Motor AC Drive. *Advances in Electrical and Computer Engineering*. 2014, 14(4) pp. 15–20, doi: [10.4316/AECE.2014.04003](https://doi.org/10.4316/AECE.2014.04003).
- [6] BRANDŠTETTER P., KUCHARŔ M., NEBORÁK I. Selected applications of artificial neural networks in the control of AC induction motor drives. *International Review on Modelling and Simulations*. 2011, 4(3) pp. 1084–1093.
- [7] KAZMIERKOWSKI M.P., MALESANI L. Current control techniques for three-phase voltage-source PWM converters: a survey. *IEEE Transaction on Industrial Electronics*. 1998, 45(5) pp. 691–703, doi: [10.1109/41.720325](https://doi.org/10.1109/41.720325).
- [8] LEONHARD W. *Control of Electrical Drives*. Berlin: Springer-Verlag, 2001, doi: [10.1007/978-3-642-56649-3](https://doi.org/10.1007/978-3-642-56649-3).

- [9] LEVIN A.U., NARENDRA K.S.: Control of non-linear dynamical systems using neural networks – Part II: Observability, identification, and control. *IEEE Transaction on Neural Networks*. 1996, 7(1) pp. 30–42, doi: [10.1109/72.478390](https://doi.org/10.1109/72.478390).
- [10] NARENDRA K.S., PARTHASARATHY K. Identification and control of dynamical systems using neural networks. *IEEE Transaction on Neural Networks*. 1990, 1(1) pp. 4–27, doi: [10.1109/72.80202](https://doi.org/10.1109/72.80202).
- [11] PERDUKOVÁ D., FEDOR P. The Identification of Induction Motor Inner Values. *International Conference on Applied Electrical Engineering and Informatics*, Germany. 2012, pp. 76–80.
- [12] SHAW S.R., LEEB S.B. Identification of induction motor parameters from transient stator current measurements. *IEEE Transaction on Industrial Electronics*. 1999, 46(1), pp. 139–149, doi: [10.1109/41.744405](https://doi.org/10.1109/41.744405).
- [13] TIMKO J., ŽILKOVÁ J., BALARA D. *Applications of artificial neural networks in electrical drives*. Košice: Calypso s.r.o, 2002.
- [14] VAS P. *Parameter estimation, condition monitoring and diagnosis of electrical machines*. Oxford: Oxford University Press, 1993.
- [15] VAS P. *Artificial-intelligence-based electrical machines and drives*. Oxford: Oxford University Press, 1999.
- [16] ZÁSKALICKÝ P. Complex fourier series analysis of a three-phase induction motor supplied by a three-phase inverter with PWM output voltage control. *Power Electronics and Motion Control Conference and Exposition (PEMC), 2014, 16th International*, Antalya, Turkey. 2014, pp. 1183–1188, doi: [10.1109/EPEPMC.2014.6980672](https://doi.org/10.1109/EPEPMC.2014.6980672).
- [17] ŽILKOVÁ J., TIMKO J. On-line identification of a rotor resistor of an induction motor using the neural network. *Electrotechnica et Informatica*. 2003, 3(1) pp. 53–56.