

QUANTUM

SEPTEMBER/OCTOBER 1998

US \$7.50/CAN \$10.50



B.B. 98



Springer



Chester Dale Collection, © 1998 Board of Trustees, National Gallery of Art, Washington

Saint Lucy (c. 1625–1630) by Francisco de Zurbarán

ACCORDING TO LEGEND, SAINT LUCY PLUCKED OUT her own eyes and sent them to a Roman suitor after he had insisted that her beauty allowed him no peace. This act of devotion so moved the suitor that he converted to Christianity. Later, Lucy's eyesight was miraculously restored one day during prayer.

The young saint's connection with eyes may have originated from the Latin source for her name, *Lux*, or "light," which is inextricably linked with vision. So, if you're having eyesight troubles, you should see an optometrist, but you may also want to remember December 13, Saint Lucy's feast day. For a focused discussion of eyesight and light, turn to page 48.

QUANTUM

SEPTEMBER/OCTOBER 1998

VOLUME 9, NUMBER 1

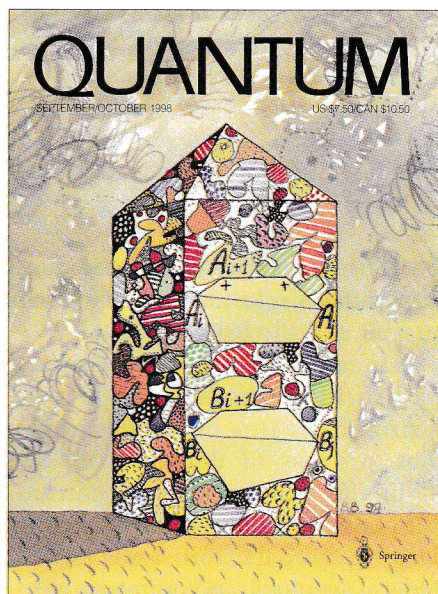

Cover art by Vasily Vlasov

Here at the Washington-area headquarters of *Quantum*, we have the opportunity to view one of the most famous rigid polyhedrons of all time—the Washington Monument.

Unfortunately, members of Congress often seem inspired by the monument's lack of flexibility, especially when it comes time to balance the budget. In the past, their strict adherence to party lines has led to a government shutdown. But enough local color. For the first of a pair of articles dealing with the rules governing the flexibility and rigidity of polyhedrons, turn to page 4.

Indexed in *Magazine Article Summaries*, *Academic Abstracts*, *Academic Search*, *Vocational Search*, *MasterFILE*, and *General Science Source*. Available in microform, electronic, or paper format from University Microfilms International.

FEATURES

- 4 **Build-it-yourself Math**
Flexible polyhedral surfaces
by V. A. Alexandrov
- 8 **Solid Solutions**
Rigidity of convex polyhedrons
by N. P. Dolbilin
- 14 **Flight Dynamics**
Why don't planes fly with cats and dogs?
by S. K. Betyaev
- 20 **Alternate Geometries**
Euclidean complications
by I. Sabitov
- 26 **Nonlinear Physics**
Sound power
by O. V. Rudenko and V. O. Cherkezyan

DEPARTMENTS

- 2 **Front Matter**
- 19 **Brainteasers**
- 32 **Kaleidoscope**
Do you really know vapors?
- 34 **Physics Contest**
Up, up and away
- 37 **How Do You Figure?**
- 38 **At the Blackboard I**
High-speed conservation
- 42 **At the Blackboard II**
Auxillary polynomials
- 46 **In the Lab**
Magnetic fieldwork
- 48 **At the Blackboard III**
In focus
- 56 **Happenings**
Fire and Ice: The 1998 IPO ... Bulletin Board
- 50 **Answers, Hints & Solutions**
- 59 **Crisscross Science**
- 60 **Musings**
The danger of Italian restaurants
- 62 **Cowculations**
Fly Zapper
- 65 **Index of Advertisers**

*Sci*LINKS: The world's a click away

Pros and con-texts

THE NATIONAL SCIENCE Education Standards (NSES) have been out for about three years now. Have we made progress? I think most will say the jury is still out. Most will also argue that the slow progress is more related to people's reluctance to change than any basic flaws in the document. The NSES call for *everybody* to get a basic science-literacy education. They also outline how this should happen, with less emphasis on memorizing long lists of meaningless science factoids and more emphasis on inquiry-based instruction.

The advent of the NSES woke up an old whipping boy in education—textbooks. Over the past three years, there has been a lot of talk about the decline in the quality of textbooks. The criticisms center on the propagation of poorly connected factoids in textbooks, the lack of a true inquiry-based learning environment, and in some cases, the inclusion of factually incorrect information.

Unfortunately, there has been less discussion on what brought about this decline and what might be done to remedy the situation. I'd like to take a politically incorrect stance and suggest we spend less time bashing textbooks and more time working to provide more appropriate educational resources and, as a consequence, a more complete learning experience.

The challenge starts by first asking, What is the textbook's role in

education? Is it the sole source of the education of the learner? Of course not. If not, then what can it do best and what should we leave to other sources?

I believe that textbooks, at best, are a structured presentation of knowledge. (This characteristic gives fuel to the critics that stress the importance of having textbooks with the correct facts.) Textbooks, however, are also very static. Once the printer's ink hits the page, the letters and numbers are fixed. So, as a technology, the textbook represents the structure of knowledge. The World Wide Web, on the other hand, is anything but static. It also has little (knowledge) structure and is so clearly unfiltered that one has to be on constant guard about the "facts."

The National Science Teachers Association (NSTA) is launching a new project that will blend the strengths of the two technologies—textbooks and the Web—into a more responsive learning tool. NSTA will partner with textbook publishers to place symbols in specific spots within science textbooks. A *sciLINK* signals a launch point from the textbook location to page-specific enrichment paths within cyberspace. Each *sciLINK* will take learners to the same initial web address (www.sciLINKS.org). From there, users will take a cyberpath specific to the location in their textbook. Because the cyberpaths are keyed to the location in that specific text-

book, they provide information and experiences relevant to the subject matter and the learner's level.

All *sciLINKS* and related cyberpaths will be the result of a focused search by teams of professionals. The process of determining the *sciLINKS* sites begins with curriculum-enhancement producers (teams of professionals from universities, federal agencies, and nonprofit associations) identifying possible links for consideration by grade-specific NSTA teacher committees. These committees, working in concert with the NSTA staff, will establish the cyberpaths for the participating publishers.

To capitalize on the Internet's continuous flow of new and exciting resources and information, the NSTA staff will review and update the cyberpaths daily. Today's late-breaking news update from a Mars exploration mission or a major nutrition study can be included in the appropriate cyberpaths tomorrow. The result is a profound change in the role of textbooks in America's classrooms.

Now, here's the challenge: If *sciLINKS* is part of the future of textbooks, what other creative new curriculum tools can we create for the twenty-first-century learner? Send your ideas to me at gwheeler@nsta.org.

Gerald F. Wheeler is Executive Director of the National Science Teachers Association.

How to be a
QUANTUM
author

Have you written an article that you think belongs in *Quantum*? Do you have an unusual topic that students would find fun and challenging? Do you know of anyone who would make a great *Quantum* author? Write to us and we'll send you the editorial guidelines for prospective *Quantum* contributors. Scientists and teachers in any country are invited to submit material, but it must be written in colloquial English and at a level appropriate for *Quantum*'s target readership of high school and college students.

Send your inquiries to:

Managing Editor
Quantum
1840 Wilson Boulevard
Arlington VA 22201-3000

Does your library
have **QUANTUM**?

If not, talk to your librarian!

Quantum is a resource that belongs in every high school and college library.

"A first-class 'new' magazine. . . one can appreciate the meaning of quality and imaginative challenge . . . it is for anyone with an interest in science, particularly math and physics. Highly recommended."
—*Library Journal*

"It should be in every high school library [and] in most public libraries . . . we owe it to our students to make *Quantum* widely available."

—**Richard Askey, Professor of Mathematics at the University of Wisconsin, Madison**

Share the
QUANTUM
experience!

QUANTUM

THE MAGAZINE OF MATH AND SCIENCE

A publication of the National Science Teachers Association (NSTA)
of Quantum Bureau of the Russian Academy of Sciences
in conjunction with
the American Association of Physics Teachers (AAPT)
of the National Council of Teachers of Mathematics (NCTM)
The mission of the National Science Teachers Association is
to promote excellence and innovation in science teaching and learning for all.

Publisher

Gerald F. Wheeler, Executive Director, NSTA

Associate Publisher

Sergey S. Krotov, Director, Quantum Bureau,
Professor of Physics, Moscow State University

Founding Editors

Yuri A. Ossipyan, President, Quantum Bureau
Sheldon Lee Glashow, Nobel Laureate (physics), Harvard University
William P. Thurston, Fields Medalist (mathematics), University of California, Berkeley

Field Editors for Physics

Larry D. Kirkpatrick, Professor of Physics, Montana State University, MT
Albert L. Stasenko, Professor of Physics, Moscow Institute of Physics and Technology

Field Editors for Mathematics

Mark E. Saul, Computer Consultant/Coordinator, Bronxville School, NY
Igor F. Sharygin, Professor of Mathematics, Moscow State University

Managing Editor

Mike Donaldson

Art Director

Sergey Ivanov

Assistant Editor

Jennifer M. Wang

Editorial Assistants

Cara Young

Anne Burns

Special Projects Coordinator

Kenneth L. Roberts

Editorial Advisor

Timothy Weber

International Consultant

Edward Lozansky

Assistant Manager, Magazines

(Springer-Verlag)

Madeline Kraner

Advertising Managers

Paul Kuntzler (Washington office)

Jay Feinman (New York office)

Advisory Board

Bernard V. Khoury, Executive Officer, AAPT

John A. Thorpe, Executive Director, NCTM

George Berzsenyi, Professor of Mathematics,

Rose-Hulman Institute of Technology, IN

Arthur Eisenkraft, Science Department Chair,

Fox Lane High School, NY

Karen Johnston, Professor of Physics,

North Carolina State University, NC

Margaret J. Kenney, Professor of Mathematics,

Boston College, MA

Alexander Soifer, Professor of Mathematics,

University of Colorado—Colorado Springs, CO

Barbara I. Stott, Mathematics Teacher,

Riverdale High School, LA

Ted Vittitoe, Retired Physics Teacher,

Parrish, FL

Peter Vunovich, Capital Area Science & Math

Center, Lansing, MI

Editorial Consultants

Yuly Danilov, Senior Researcher,

Kurchatov Institute

Yevgeniya Morozova, Managing Editor,

Quantum Bureau

Quantum (ISSN 1048-8820) is published bimonthly by the National Science Teachers Association in cooperation with Springer-Verlag New York, Inc. Volume 9 (6 issues) will be published in 1998–1999. *Quantum* contains authorized English-language translations from *Kvant*, a physics and mathematics magazine published by Quantum Bureau (Moscow, Russia), as well as original material in English. **Editorial offices:** NSTA, 1840 Wilson Boulevard, Arlington VA 22201-3000; telephone: (703) 243-7100; electronic mail: quantum@nsta.org. **Production offices:** Springer-Verlag New York, Inc., 175 Fifth Avenue, New York NY 10010-7858.

Periodicals postage paid at New York, NY, and additional mailing offices. **Postmaster:** send address changes to: *Quantum*, Springer-Verlag New York, Inc., Journal Fulfillment Services Department, P. O. Box 2485, Secaucus NJ 07096-2485. Copyright © 1998 NSTA. Printed in U.S.A.

Subscription Information:

North America: Student rate: \$18; Personal rate (nonstudent): \$25. This rate is available to individual subscribers for personal use only from Springer-Verlag New York, Inc., when paid by personal check or charge. Subscriptions are entered with prepayment only. Institutional rate: \$47. Single Issue Price: \$7.50. Rates include postage and handling.



[Canadian customers please add 7% GST to subscription price. Springer-Verlag GST registration number is 123394918.] Subscriptions begin with next published issue (backstarts may be requested). Bulk rates for students are available. Mail order and payment to: Springer-Verlag New York, Inc., Journal Fulfillment Services Department, PO Box 2485, Secaucus, NJ 07094-2485, USA. Telephone: 1(800) SPRINGER; fax: (201) 348-4505; e-mail: custserv@springer-ny.com.

Outside North America: Personal rate: Please contact Springer-Verlag Berlin at subscriptions@springer.de. Institutional rate is US\$57; airmail delivery is US\$18 additional [all rates calculated in DM at the exchange rate current at the time of purchase]. SAL (Surface Airmail Listed) is mandatory for Japan, India, Australia, and New Zealand. Customers should ask for the appropriate price list. Orders may be placed through your bookseller or directly through Springer-Verlag, Postfach 31 13 40, D-10643 Berlin, Germany.

Advertising:

Advertising Representatives: (Washington) Paul Kuntzler (703) 243-7100; (New York) Jay Feinman (212) 460-1682; and G. Probst, Springer-Verlag GmbH & Co. KG, D-14191 Berlin, Germany, telephone 49 (0) 30-827 87-0, telex 185 411. Printed on acid-free paper.

Flexible polyhedral surfaces

Bending the rules with Euler, Cauchy, and Bricard

by V. A. Alexandrov

THE TOPIC OF POLYHEDRAL surfaces has traditionally played a central role in the study of solid geometry. Moreover, this topic can suggest many problems to anyone who wants to attain a deeper knowledge of the subject. For instance, we can start with the following list of problems:

(1) Find the lengths of the edges of the regular polyhedrons (tetrahedron, cube, octahedron, icosahedron, and dodecahedron) circumscribed about (or inscribed in) a sphere of a given radius.

(2) Prove Euler's theorem, which states that the following identity holds for any convex polyhedron:

$$V - E + F = 2,$$

where V , E , and F are, respectively, the numbers of vertices, edges, and faces of the polyhedron.

(3) Use Euler's theorem to prove that the list of regular polyhedrons given in question (1) is complete.

(4) Prove Cauchy's theorem, which states that two convex, closed polyhedral surfaces whose corresponding faces are congruent and whose faces adjoin each other in the same way are congruent.

Problem (1) doesn't go beyond the traditional classroom material. Problems (2) and (3) are not usually in-

cluded in mathematics courses, but they are quite accessible to anyone who wants to learn more about solid geometry. The most difficult problem in the list is problem (4). If you are eager to know how Cauchy's theorem is proved, see the article beginning on page 8.

In this article we will discuss some questions connected with Cauchy's theorem. More specifically, we'll show, using a counterexample, that the theorem can't be extended to nonconvex polyhedrons (an amazing fact that had remained unclear for more than 150 years, since Cauchy proved his theorem in 1813). But before we proceed, let's make some definitions.

A *polyhedral surface* is any surface in three-dimensional space consisting of a finite number of polygons. We call these polygons *faces* of the surface, and their sides we call *edges*. We assume that every edge belongs to no more than two different faces of the surface. And if every edge belongs to two faces of the surface, then we say that the surface is *closed*. A good example of a closed polyhedral surface is the surface of a cube (if we remove a face from it, the remaining part is not a closed polyhedral surface. We should stress that it's convenient to also consider *self-intersecting sur-*

faces, whose faces may have common points other than the vertices of the surface and the points lying on its edges.

We assume that it is prohibited to change the shape and size of any face (that is, we imagine that the faces are made of a solid matter). However, it's permissible to change the dihedral angles between the faces, as if the faces were connected by hinges. We call a polyhedral surface *flexible* if it is possible to change its shape by means of a continuous deformation of its dihedral angles. Clearly, the (nonclosed) polyhedral surface consisting of two triangles connected along one edge is flexible.

The rest of our article will discuss the question of whether or not closed, flexible polyhedral surfaces (without self-intersections) exist.

We say that a polyhedral surface is *convex* if it is the boundary of a convex set of points. (A set of points is convex if any line segment connecting two of its points is contained within the set.) Cauchy's theorem implies that no closed, convex polyhedral surface is flexible.

In 1897 the French mathematician R. Bricard described all possible flexible octahedrons. According to Cauchy's theorem, none of them can be convex. It has become a tra-

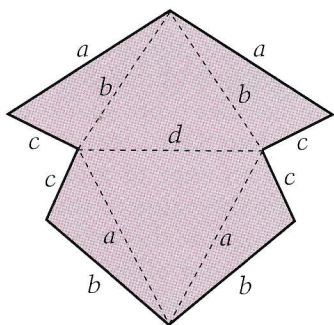

Figure 1

dition to divide all flexible octahedrons, also known as Bricard's octahedrons, into three types. In this article we'll consider only one type.

First we'll explain how to assemble a cardboard model of this octahedron. Copy the figure composed of six triangles shown in figure 1 on a sheet of cardboard. Here the letters a , b , c , and d denote the lengths of the corresponding edges. For example, it is convenient to make $a = 12$, $b = 10$, $c = 5$, and $d = 11$. (The reader should check that these are in fact possible lengths for the polyhedron's edges.) Cut along the solid lines, then fold along the dotted lines as follows. Fold the two triangle flaps (one of whose sides has length c) on the left of the figure toward yourself and glue them together along the side of length c . Fold two similar triangle flaps on the right of the figure in the other direction and glue them together along the side of length c . You will obtain the nonconvex, nonclosed polyhedral surface P shown in figure 2. Solid lines in this figure represent the visible edges of the surface, and the dotted lines represent the edges screened by the faces. The edges AE , ED , DF , and FA make up the border of this surface, and each of them adjoins only one face of the surface P .

The polyhedral surface P is clearly flexible: If we fix the position of triangle BCE in space, we can move point F in the directions shown by the arrows in figure 2. The positions of points A and D will also vary, but most important, the distance between them will remain constant.

To make sure that this is so, let's consider the dihedral angle S with

edge EF , whose facets are the half plane s_1 passing through B and the half plane s_2 passing through C . Let's rotate the half plane s_1 about EF so that the new half plane t_1 contains point A . That is, we rotate it toward the viewer through an angle equal to the dihedral angle at edge EF of tetrahedron $BAEF$. Similarly, let's rotate the half plane s_2 about the line EF so that the new half plane t_2 contains D . To do so we rotate it away from the viewer through an angle equal to the dihedral angle at edge EF of the tetrahedron $CDEF$. But, regardless of the position of point F , these tetrahedrons have equal corresponding edges (see fig. 2), and thus they are congruent. In particular, their dihedral angles at the edge EF are equal. Therefore, the dihedral angle T formed by half planes t_1 and t_2 is equal to the dihedral angle S .

So, we see that in tetrahedrons $BCEF$ and $ADEF$, we can point out five pairs of equal corresponding edges ($BE = AF$, $BF = AE$, $CF = DE$, $CE = DF$, and EF is their common edge) and a pair of equal dihedral angles, S and T , opposing their sixth edges (BC and AD , respectively). Thus, tetrahedrons $BCEF$ and $ADEF$ are congruent, and therefore $AD = BC = d$ for all possible positions of vertex F .

Since AD has a constant length independent of the position of F , we conclude that we can attach two imaginary cardboard triangles ADE and ADF to the surface P such that the resulting closed polyhedral surface Q will remain flexible. Of course, this procedure can be carried out only in our imagination, because

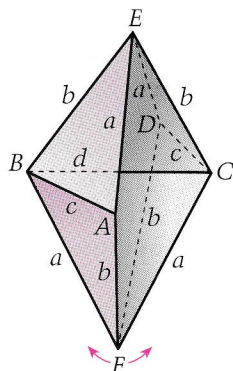

Figure 2

it results in self-intersections. For example, faces ADE and BCE will intersect each other along a line that is not an edge of the surface Q . When we start shifting vertex F , this line changes its position on each of the faces ADE and BCE . And it's impossible to imitate this process in a cardboard model.

So it is this surface Q that is one of Bricard's octahedrons. Like the usual octahedron, it has 6 vertices (A , B , C , D , E , and F), 12 edges (AB , AD , AE , AF , BC , BE , BF , CD , CE , CF , DE , and DF) and 8 faces (ABE , ABF , BCE , BCF , CDE , CDF , ADE , and ADF). Nonetheless, unlike the usual octahedron, Bricard's is flexible, nonconvex, and self-intersecting. Now we're going to modify this construction so that the self-intersections vanish.

Steffen's surface

We will start by gluing together two congruent copies P_1 and P_2 of the polyhedral surface P in a certain way. We'll denote the vertices of the surface P_1 by the letters we've used for the corresponding vertices of P , but with the index 1. We'll employ similar notation for P_2 .

Now draw on cardboard the quadrilateral consisting of two congruent triangles shown at the top of figure 3. Here the letters a and e denote, as before, the lengths of the corresponding sides. If above you've chosen $a = 12$, now it is convenient to take $e = 17$. Cut this figure from the cardboard along the solid lines and fold it along the dotted line. You will obtain the nonclosed polyhedral surface, which we'll call R , shown in figure 3.

Fix the position of the surface R in space such that the distance between L and N is equal to d . In other words, in what follows, we won't change the value of the dihedral angle at edge KM of the surface R .

Superimpose points K and E_1 , A_1 and L , and D_1 and N , and glue surfaces P_1 and R along the edges A_1E_1 and KL and along the edges E_1D_1 and KN (fig. 4). It is clear that we can still shift vertex F_1 as we did before, even though the position of the surface R

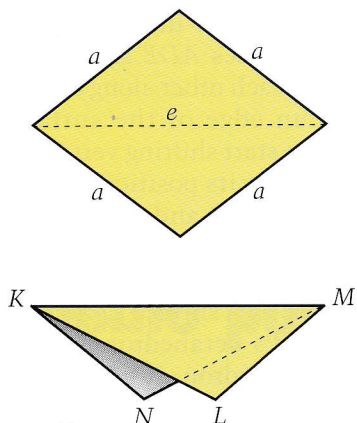

Figure 3

is fixed (because the constant distance between points A and D does not deny Bricard's octahedron the ability to twist, and P_1 is just a part of this octahedron). Moreover, point F_1 can move freely along the circle that lies in the plane perpendicular to segment A_1D_1 and whose center lies in the middle of this segment. The faces of surfaces R and P_1 will not change their shape; only certain dihedral angles will vary.

In a similar way, superimpose points E_2 and M , D_2 and L , and A_2 and N and glue surfaces P_2 and R along edges A_2E_2 and MN and along edges D_2E_2 and LM (fig. 4). We see that point F_2 can move along the same circle that point F_1 can move along. Therefore, if we have given an arbitrary shape to surface P_1 (that is, if we have fixed the position of vertex F_1 on the aforementioned circle) we can twist surface P_2 (preserving the shape of its faces, of course), so that vertex F_2 coincides with F_1 . But

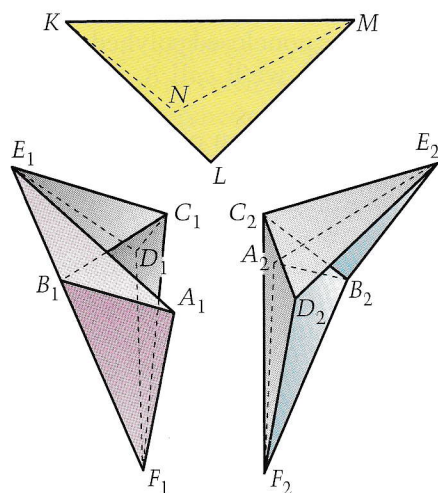

Figure 4

then edges A_1F_1 and D_2F_2 will match up, as will edges D_1F_1 and A_2F_2 , and we'll obtain a closed polyhedral surface that is flexible because we were free when we chose the position of F_1 (or F_2 , which is the same). This polyhedral surface is called *Steffen's polyhedral surface*. It has only nine vertices, which is just one vertex more than a cube has. (It is helpful to make triangle KLM transparent: You will see what is going on inside Steffen's surface when you twist it.)

Now let's discuss some properties of flexible polyhedral surfaces. Every closed polyhedral surface without self-intersections bounds a body in three-dimensional space, and the volume of this body is finite. The so-called *bellows conjecture* says that if the surface is flexible, the volume of this body remains constant when the surface twists. This conjecture appeared in 1978 as a result of investigations of the first examples of closed,

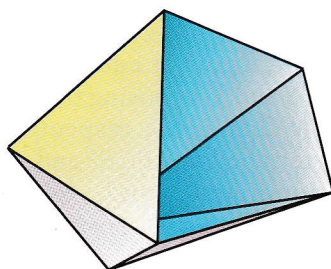

Figure 5

flexible polyhedral surfaces without self-intersections invented by R. Connelly. In 1995 the Russian mathematician I. H. Sabitov proved this conjecture. Just imagine: Steffen's surface would be flexible even if it were hermetically sealed and filled with an incompressible liquid!

A natural question arises: Are there any other quantities that characterize a polyhedral surface and remain constant when the surface is twisted? A trivial example of such a quantity is the area of the surface. Another, more significant example is given by the following construction.

Let's define the *interior dihedral angle* at an edge of a closed polyhedral surface as the angular measure

of the dihedral angle at this edge, measured from the side where the body of finite volume bounded by the surface lies (note that it can be greater than 180°). Multiply the length of an edge of a polyhedral surface by the value of the interior dihedral angle at this edge and sum the products for all edges. The resulting number is called the *mean curvature* of the polyhedral surface. The American mathematician R. Alexander established in 1985 that the mean curvature of a closed, flexible polyhedral surface does not vary when the surface is twisted.

Real-world applications?

Here we must confess that no practical applications have been found in the 20 years since interest in the subject of closed, flexible surfaces was revived. But we mustn't despair, for it has often happened in the history of science that the first practical applications of some phenomenon were found only many years after it had been theoretically established. For instance, more than 50 years elapsed between the theoretical discovery of electromagnetic waves and the first radio broadcast.

And, although we don't yet know any real nontrivial applications of this theory, we can point out one very promising direction of thought. Modern chemistry explains many properties of different substances by the geometric structure of their molecules. A molecule can be viewed as a polyhedron with atoms at its vertices and whose edges correspond to the interatomic connections in the molecule. And, while the distances between the atoms cannot vary, there is nothing preventing the dihedral angles between the faces of this polyhedron from changing.

So, we can imagine a substance whose molecules have the form of a flexible surface. The chemical and physical properties of this substance would change as the form of its molecules changed! No such substances have yet been found. But who knows what might happen in the future? ◼

Revolutionize Your Curriculum!

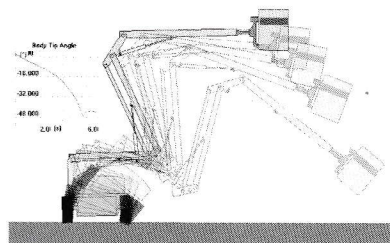

With Working Model 2D, you use tools from the palette to quickly sketch your mechanical system, or import your two dimensional CAD drawings in DXF format. With just a mouse click you interact with tools such as springs, dampers, and forces. Input controls and analysis tools, such as graphs and vectors, highlight the dynamics of your simulation.

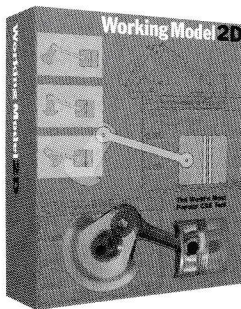

Our Integrated Mathematics and Science Solutions Redefine Your Educational Environment

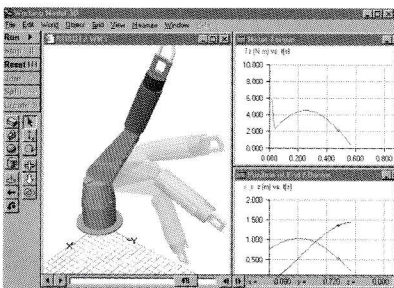

With Working Model 3D, you exercise complete control over the simulation environment, including constraints and parameters. With Working Model's complete set of analysis tools, you can measure, graph, or export data on any simulation parameter. You can even create complex, non-linear simulation elements with its function language. Working Model 3D supports solid models from ACIS, Mechanical Desktop, Solid Edge, SolidWorks, and Pro/ENGINEER.

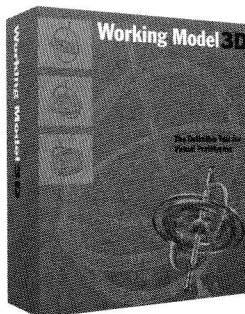

Working Model is the standard motion simulation solution used in mechanical engineering departments around the world. It allows you to explore dynamics by simulating a wide range of mechanical models - from the oscillatory motion of a simple pendulum to the complex behavior of a gyroscope. *Working Model* supports the design process by allowing students to brainstorm, test, and refine mechanical assemblies within the software environment. Whether your specialty is biomechanics, vibrations, mechanical design, or control systems, the *Working Model* 2D and 3D suite offers powerful educational solutions.

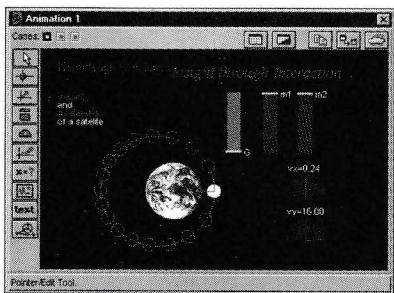

With Modellus, simulations are created from mathematical equations. Explore scientific models by interacting with algebraic, differential, and iterative equations in the context of a physical system.

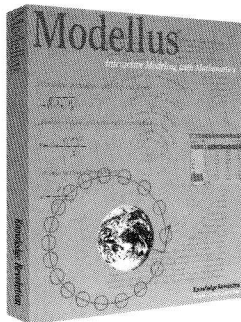

Modellus™ gives students the power to interact with models in real time to gain powerful insights into the underlying mathematics. Its equation-based approach to modeling offers a powerful new technology for mathematics and science learning. Typical math programs act as calculators, treating the model as a static entity. But *Modellus* lets students manipulate mathematical variables during a simulation to study the effects of their changes on animations, graphs and tables. By supporting multiple cases and multiple data representations, *Modellus* offers students valuable feedback during the problem solving process.



Knowledge Revolution *Insight through Interaction*

66 Bovet Road, Suite 200
San Mateo, California 94402
Fax 650 574 7541
Telephone 650 574 7777
Toll-Free 800 766 6615

www.krev.com

Rigidity of convex polyhedrons

The inflexible findings of Cauchy and Euler

by N. P. Dolbilin

IN THE PRECEDING ARTICLE, beginning on page 4, we learned how to construct a flexible polyhedron. Here we examine why a flexible polyhedron *must* be convex.

Anyone who has ever made, or simply held, a paper model of a convex polyhedron probably noticed that it was not flexible and might have wondered why not.

Those who wondered may have intuitively reasoned that the rigidity of the model is not just a matter of chance but rather is predetermined by some intricate hidden

relationships among the faces of the polyhedron.

The question of the rigidity of a polyhedron is an old geometrical problem, and, as it turned out, quite a difficult one. It was finally solved only about 20 years ago, and the first step to its solution was made in 1813 by the outstanding French

mathematician Augustin-Louis Cauchy, an alumnus of the famous Ecole Polytechnique in Paris, who was then only 23 years old.¹

Cauchy graduated from the Ecole Polytechnique in 1807, and according to the well-known German mathematician Felix Klein, "one can put him for his wonderful achievements in various branches of mathematics on almost the same plane as Gauss." This high estimate of Cauchy's work holds particular significance, since competition between French and German mathematicians was generally very sharp, and acknowledgments by each party of its counterpart's merits were scant.

The results that brought Cauchy fame as a great mathematician are concerned, foremost, with the calculus, algebra, mathematical physics, and me-

¹For an account of the founding of the Ecole Polytechnique, see "Revolutionary Teaching" on page 26 of the March/April 1998 *Quantum*.

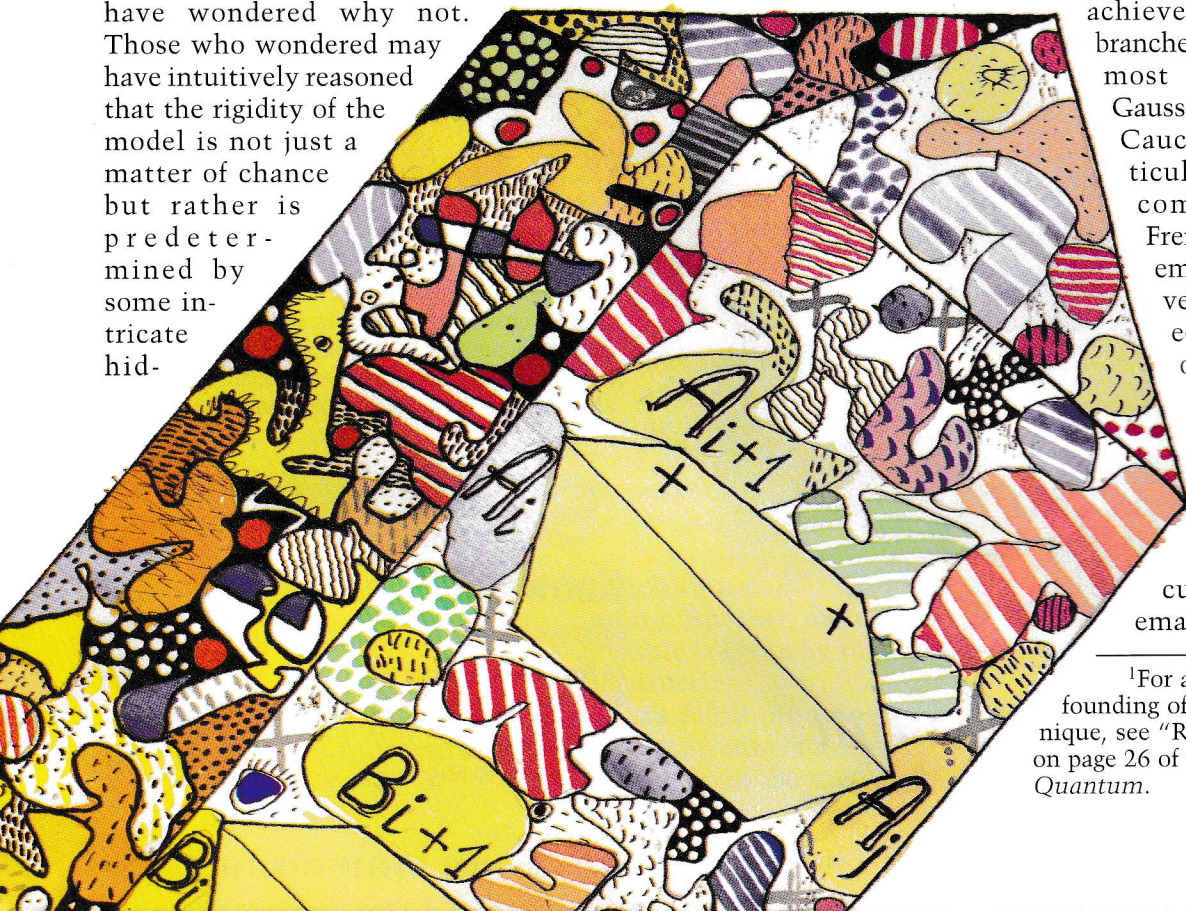

chanics. His work on geometry would perhaps remain lost in his vast scientific legacy, which fills 25 huge volumes, if not for his paper "On polygons and polytopes," published in the *Journal de l'Ecole Polytechnique* in 1813.

Cauchy's uniqueness theorem

Cauchy's paper on polytopes explores the following natural question: To what extent do the faces of a polyhedron and the order in which they adjoin each other determine the shape of the polyhedron? Let's give an example to explain the purpose of this question. Consider two polyhedrons: a tower with a four-slope "roof" on a cubical foundation and another tower made of the same faces but with the "roof" pushed into it (figs. 1 and 2).

It's clear that these two polyhedrons are not congruent, even though they are made of corresponding congruent polygonal faces that abut each other in the same manner. Cauchy demonstrated that nothing of this sort can happen when both polyhedrons are convex.

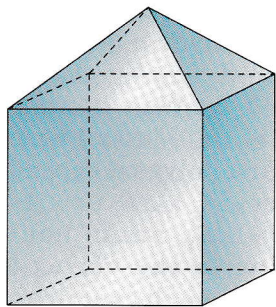

Figure 1

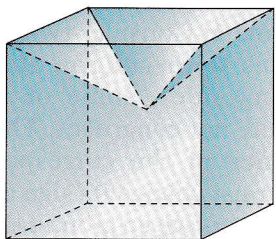

Figure 2

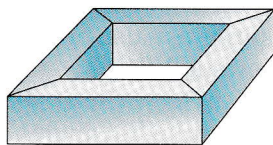

Figure 3

Cauchy's theorem: Two convex polyhedrons whose corresponding faces are congruent and adjoin each other in the same way are also congruent.

The Russian academician A. D. Alexandrov called the main idea of this theorem's proof "one of the most brilliant arguments ever to appear in geometry." In time, this beautiful argument has become a common method used to prove other uniqueness theorems.

Euler's conjecture

The question of whether the shape of a polyhedron was determined in a unique way by its faces or if the surface could somehow vary despite its faces remaining unchanged had attracted mathematicians' attention long before Cauchy. Indeed, the great Euler himself pondered the problem of uniqueness.

In 1766 Euler made the following conjecture: "A closed spatial figure does not admit variation unless it is torn." What Euler called a "closed

spatial figure" is nowadays called a closed surface. Thus, Euler's conjecture was concerned not just with polyhedral surfaces. But, in the case of polyhedrons, it seemed quite correct.

Simple polytopes

Before we proceed, let's clarify some notions. Let's define *polytope* (or *polyhedron*) as the surface composed of polygons and not the body bounded by it. We will also assume that our polytope is made of a finite number of polygonal faces such that to each edge of each face exactly one other face is attached. (It is difficult to give a strict mathematical definition of a polytope that would embrace convex and nonconvex polytopes, so we will not attempt this.) Polytopes that comply with the last condition are referred to as *closed*. This definition is a natural one. All the polytopes that we encounter in school (prisms, pyramids, regular polyhedrons) are closed. An open cardboard box is not closed, but a closed box, of course, is.

We will also assume that our polytopes are topological spheres. A *topological sphere* is any surface that can be compared to a deflated soccer ball. In other words, if our polytope was made of rubber, we would be able to transform it into a sphere without cutting and pasting. Let's agree to call such polytopes *simple*. All convex polytopes are simple, as are both polytopes in figures 1 and 2. Figure 3 shows an example of a *toroidal* polytope, which is not simple.



Sometimes a polytope is so badly "tangled" that it is difficult to understand whether or not it is simple. Thus, it's remarkable that we can determine whether or not a polytope is simple even when simply viewing it causes confusion. Suppose someone tells you the numbers of vertices V , of edges E , and of faces F of a polytope X . Then you can calculate the number $\phi(X)$ defined by the formula

$$\phi(X) = V - E + F.$$

This number $\phi(X)$ is called the *Euler characteristic* of the polytope X . This number indicates whether or not X is simple: The polytope X is simple if and only if its Euler characteristic is equal to 2. The Euler characteristic of non-simple polytopes does not exceed 0. In particular, the Euler characteristic of toroidal polytopes (fig. 3) is zero (we invite the reader to check this).

Flexibility of polytopes

Imagine a polytope made of several cardboard polygons attached to each other by adhesive tape (of course, it will be finite, closed, and simple). Clearly, since all the connections are flexible, it would be possible to rotate any two faces about their common edge and thus change the dihedral angle between them ... if there were no other faces.

And when all the faces are connected to form a polytope, we can ask if it is possible to change the shape of the polytope continuously so that all its faces remain unchanged while the dihedral angles between them vary. If this can happen, we call the polytope *flexible*; otherwise we call it *rigid*.

Thus, any deformation of a polytope, if it exists, is related to the flexibility of its dihedral angles. Moreover, although each pair of adjoining faces is free to choose the value of the dihedral angle that it forms, it seems quite possible that it loses this freedom in the presence of the other faces. It seems possible that Euler based his conjecture on

the rigidity of closed polytopes on "plausible reasonings" of this sort.

The article on page 4 shows that Euler was not right. For, although it was proved in 1975 that "almost all" polyhedrons are rigid, almost all is not *all*, and the previous article gave an example of a flexible polytope. The first example of a flexible polyhedron was proposed only in 1978 by the American mathematician R. Connelly.

By the way, it is more difficult than it might seem to find such a polytope. For instance, a bellows does not give the necessary example, because its ability to change its form is due to the elasticity of the material and not to its geometrical structure. In effect, if a bellows were made in the form of a flexible polytope, it would be useless, for every such polytope maintains a constant volume in the process of deformation. (This is the statement of the *bellows conjecture*, proved in 1995 by the Russian mathematician I. H. Sabitov. In fact, Sabitov proved an analogue of Heron's formula for polytopes, which expresses the volume of the polytope in terms of the lengths of its edges and the areas of its faces. This is a remarkable result. Note, for example, that there can be no analogue of Heron's formula in two dimensions for polygons of more than three sides: Their areas are not determined solely by the lengths of their sides.)

Note that Cauchy's theorem implies that flexible polytopes *must* be nonconvex. Clearly, the flexibility of a polytope means that there can be other polytopes made of the same faces in the same order that are different from the original polytope because their dihedral angles are slightly different. At the same time, if the original polytope is convex, then the other one, whose dihedral angles are slightly different, must also be convex. But if our original flexible polyhedron were convex, then we could change its dihedral angles by a sufficiently small amount that it would form a new convex polyhe-

dron, and this is in direct contradiction to Cauchy's theorem, which states that such polytopes should be congruent.

Now we proceed to the main ideas of the proof of Cauchy's theorem.

Cauchy's lemma on convex polygons

To prove Cauchy's theorem, we first look more closely at some properties of polygons. It is no coincidence that the word *polygon* is in the title of Cauchy's work on polyhedrons. Imagine a plane polygon made of rods with hinges at the ends. In the case of a triangle, the lengths of the rods determine the angles between them (the "SSS" criterion of congruence for triangles), and the construction is rigid. This familiar geometrical fact finds numerous applications in our everyday life: All constructions made of rods that must bear heavy loads (bridge girders, arms of cranes, roofs, and so on) contain triangular elements for the sake of rigidity.

If the number of sides of a polygon is greater than three, then its angles can't be determined by the lengths of its sides, and thus the polygon isn't determined by them, either. However, Cauchy noted one fact about such polygons that came in handy when he proved his theorem.

Let $A = A_1A_2 \dots A_n$ and $B = B_1B_2 \dots B_n$ be convex n -gons such that $A_1A_2 = B_1B_2, \dots, A_{n-1}A_n = B_{n-1}B_n, A_nA_1 = B_nB_1$. We will ascribe the signs "+" or "-" to all vertices A_i of the first polygon, depending on whether $\angle A_i > \angle B_i$ or $\angle A_i < \angle B_i$. If $\angle A_i = \angle B_i$, we do not assign anything to the vertex A_i (we will call such vertices "unmarked"). Before we formulate Cauchy's lemma, let's prove the following:

Lemma 1: Consider two convex polygons with congruent corresponding sides, some of whose angles are not congruent. Then the difference of the corresponding angles must change its sign at least four times as we go around the borders of the two polygons.

It is not hard to see that the num-

ber of alternations must be even and nonzero. Thus, it is enough to show that it isn't equal to 2, which is the main idea of the proof.

Suppose that the number of alternations is two. Then polygon A splits into two broken lines: Some of the vertices of the first broken line $A_i A_{i+1} \dots A_j$ are marked with the sign "+", and there are no vertices marked by "-" in it. The other broken line, $A_j A_{j+1} \dots A_i$, contains some vertices marked by "-", and none of its vertices are marked with "+" (fig. 4).

Therefore, it is possible to obtain the broken line $A_i A_{i+1} \dots A_j$ from the corresponding broken line $B_i B_{i+1} \dots B_j$ of polygon B by increasing some of the angles of the latter. It seems clear that the length of the segment that connects the beginning and the end of the broken line must increase during this operation—that is, $A_i A_j > B_i B_j$. (The strict proof of this statement is rather cumbersome, and we will omit it.)

On the other hand, the second broken line $A_j A_{j+1} \dots A_i$ of polygon A is obtained from the corresponding broken line $B_j B_{j+1} \dots B_i$ of polygon B if we decrease some of the angles of the latter. The segment connecting the ends of the broken line will become shorter. Therefore, we conclude that $A_i A_j < B_i B_j$. These two inequalities contradict each other, and so the original assumption that there are exactly two alternations of sign is wrong. Thus, the number of alternations is greater than or equal to four.

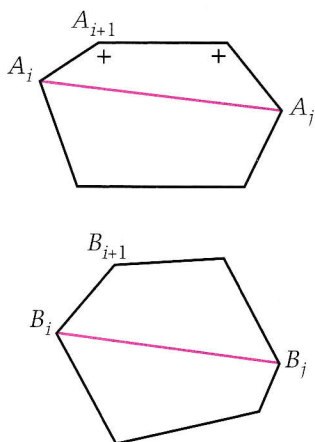

Figure 4

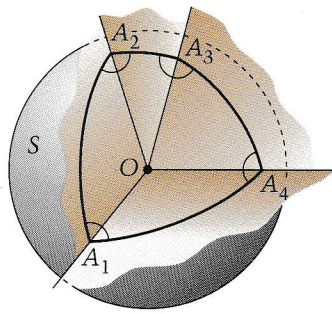

Figure 5

Now that it is proven, we'll use lemma 1 to prove Cauchy's theorem, although we'll have to change its setting slightly so that it deals with convex polygons on a sphere. The statement and proof of this variation of lemma 1 will remain the same, but we must explain the corresponding definitions.

The definition of a *spherical polygon* is quite similar to the definition of a planar polygon. We just have to keep several things in mind. First, a *side* of a spherical polygon is an arc of a great circle, and the *length* of a side is the length of the corresponding arc. Second, an *angle* of a spherical polygon is the angle between the tangents drawn to the sides (arcs) at the point of intersection (that is, at the vertex of the polygon). We can see that this angle is equal to the linear measure of the dihedral angle between the planes of the corresponding great circles (fig. 5). Third, we call a spherical polygon *convex* if it lies completely in one of the two hemispheres into which the sphere is divided by a great circle containing one of its sides.

Cauchy's main lemma

Suppose that there are two non-congruent polyhedrons that comply with the conditions of Cauchy's theorem. Then we will be able to point out pairs of corresponding unequal dihedral angles in them. We'll mark each edge of one of these polyhedrons with a "+" if the dihedral angle at this edge is greater than the corresponding dihedral angle in the other polyhedron, or a "-" if it is less. Of course, it can happen that some of the edges will remain un-

marked, since there might be equal corresponding dihedral angles.

Let's choose a vertex O of the polyhedron that is an endpoint of some of the marked edges, and draw a sphere S with a small radius, centered at O . By "small radius," we mean that it is so small that the sphere S does not intersect any edges of the polyhedron except for those with endpoints at O . Each such edge intersects the sphere exactly once, and these intersections determine a convex spherical polygon M whose angles are equal to the corresponding dihedral angles of the polyhedron.

Now if we draw another sphere S' with the same radius and center at the corresponding vertex O' of the other polyhedron, we obtain another polygon M' on it. The sides of polygon M' are equal to the corresponding sides of polygon M . This equality follows directly from the conditions of the theorem: In the corresponding vertices of the polygons, corresponding congruent faces are adjacent.

Now it's time to use lemma 1. We suppose that Cauchy's uniqueness theorem is not valid. Therefore, there must be at least one edge marked with either "+" or "-". Applying lemma 1 to polygons M and M' , we see that if there is a marked edge at the vertex, then there must be at least four alternations of the signs assigned to the edges around the vertex.

It may seem that there is still a long way to go from this simple observation to the complete proof of the theorem. But here Cauchy found an original idea that made the rest of the proof just a matter of technique. It turns out that the following statement holds.

Lemma 2. Let some of the edges of a closed, convex polytope be marked with a "+" or "-". Consider all the vertices of the polytope such that at least one of the edges with endpoints at these vertices is marked. Then there must be a vertex among them with fewer than four alternations of signs assigned to the edges around it.

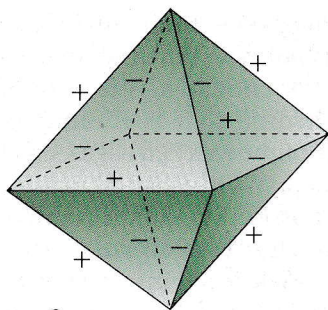

Figure 6

For instance, figure 6 represents an octahedron that has two vertices for which the number of alternations of sign is equal to two.

The underlying idea of the proof of the main lemma is clearest in the particular case when every edge bears a sign. Suppose that this is true. As before, let V be the number of vertices of the polytope, E the number of edges, F the number of faces, and N the total number of alternations of sign around all the vertices. To prove lemma 2, it's enough to show that $N < 4V$.

We will follow Cauchy's reasoning and prove a stronger inequality: $N \leq 4V - 8$.

It is easy to see that the total number of alternations of sign around all the vertices is equal to the total number of alternations of sign that one can count by going along the edges of all faces. Indeed, each pair of adjacent vertices with endpoints at one vertex is also a pair of adjacent vertices in the border of the corresponding face (fig. 7).

Let F_n denote the number of n -gonal faces of the polytope $n \leq 3$. Then

$$F = F_3 + F_4 + F_5 + F_6 + \dots \quad (1)$$

Now the number of sign alternations along the border of an n -gon is less than or equal to n , and when n is odd, it's not greater than $n - 1$. Therefore,

$$N \leq 2F_3 + 4F_4 + 4F_5 + 6F_6 + 6F_7 + \dots \quad (2)$$

Since every edge belongs to two faces,

$$2E = 3F_3 + 4F_4 + 5F_5 + 6F_6 + \dots \quad (3)$$

Let's rewrite Euler's formula in the

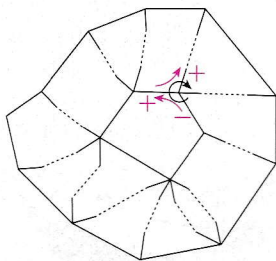

Figure 7

following form:

$$4V - 8 = 4E - 4F. \quad (4)$$

Substituting the expressions from equations (1) and (3) for F and E in equation (4), we obtain

$$4V - 8 = 2(3F_3 + 4F_4 + 5F_5 + \dots) - 2(2F_3 + 2F_4 + 2F_5 + \dots) = 2F_3 + 4F_4 + 6F_5 + \dots \quad (5)$$

The coefficient of F_n in equation (5) is equal to $2(n - 2)$ and thus, if $n \geq 3$, it is not less than the corresponding factor in (2), which does not exceed n . Therefore, equations (2) and (5) imply the necessary inequality: $N \leq 4V - 8$.

(In the general case, when it may happen that some of the edges are unmarked, the proof is complicated by unimportant technical details, and we will omit them.)

Note that in our proof of lemma 2 we haven't used the convexity of the closed polytopes: This lemma holds for arbitrary closed polyhedrons. We used this assumption only to satisfy the conditions of lemma 1.

Let's reformulate our final conclusion. If Cauchy's theorem were incorrect, then, according to lemma 1, we would obtain a set of signs assigned to each edge that would be impossible according to lemma 2. This is the main idea of the proof of Cauchy's theorem.

Alexandrov's sufficiency theorem

When Cauchy's paper on polygons was published, its author's interests were already very far from this branch of mathematics. However, many other mathematicians studied similar questions. For example, many profound results in this field were ob-

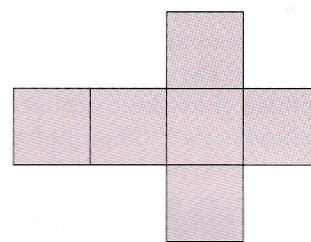

Figure 8

tained by the Russian mathematician A. D. Alexandrov and his students. In 1939 Alexandrov proved a theorem that gives necessary conditions for determining the development of a convex polyhedron.

Roughly, a *development* of a polyhedron is a polygon obtained by cutting the surface of the polyhedron so that its faces can be spread out flat on a plane. For instance, figure 8 shows the standard development of a cube. It is much more difficult to understand that the polygon shown in figure 9a is also a development of a cube. The letters assigned to the vertices in figure 9a determine the sides that must be glued together (fig. 9b). Let's note that the polygons of the development do not necessarily coincide with the faces of the corresponding polytope. It can happen that a face consists of one or several pieces of different polygons from the development. Note also that not every vertex of the development must coincide with a vertex of the polytope; some vertices might be "hidden" inside an edge or a face of the polytope.

Consider an arbitrary development: Take several convex paper polygons and note which sides of these polygons should be glued together. Of course, we must see that the lengths of the corresponding sides are equal. Then glue the polygons together to form the polytope that had been developed (note that it is permissible to fold the polygons of the development). A natural question arises: Which developments can in this way produce a convex polyhedron? The following two conditions are necessary for this:

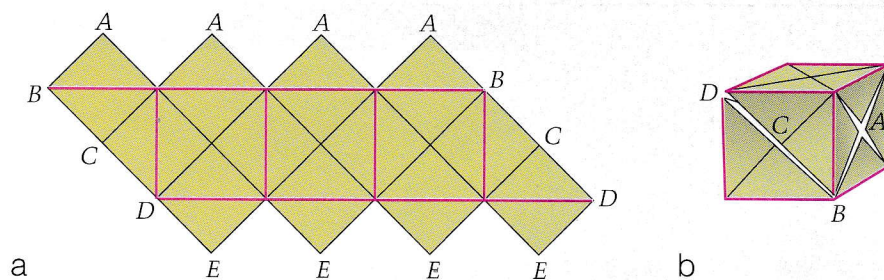

Figure 9

(I) The development must comply with Euler's formula ($V - E + F = 2$).
 (II) The sum of the plane angles around each vertex in the process of gluing must not exceed 360° .

The idea of Alexandrov's theorem is strikingly simple: Conditions (I) and (II) are not just necessary, but also sufficient, for determining the development to be that of a convex polygon (although it can happen that we will have to fold the interior of some polygons of the development).

Later Alexandrov developed the ideas that underlie this theorem into a whole new theory: the internal geometry of convex surfaces—one of the most important branches of modern geometry.

Let's look again at figure 9a. Even if we didn't see figure 9b, we would still be able to say that this development can be glued into a convex polytope just by checking the conditions of Alexandrov's theorem for it. How many different convex polyhedrons can we obtain from one development? Since the faces of such polytopes are not determined in a unique way, Cauchy's theorem

can't be used to answer this question. So, Alexandrov proved another theorem that on one hand strengthened Cauchy's theorem and on the other made his own theorem more complete: If it is possible to glue a development into a convex polytope, then this polytope is uniquely determined.

Moreover, it is impossible to glue this development onto any other convex surface at all—not only polyhedral but even curvilinear. This supplement to Alexandrov's theorem was proved in 1942 by his young pupil S. P. Olovianishnikov.¹

The most complete generalization of Cauchy's theorem, which would include arbitrary surfaces (and not just polyhedrons), remained unsolved for a long time. Consider an arbitrary surface made of a thin, flexible, but non-stretchable material. Is it possible to retain the convexity and transform it into a different surface? If the original surface is a convex polytope, then we can't do it. This is a particular case of Cauchy-Alexandrov-Olovianishnikov's uniqueness theorem.

The final generalization of Cauchy's theorem that would include the case of arbitrary surfaces was given in 1949 by the geometer A. V. Pogorelov, another student of Alexandrov. Pogorelov showed that no closed, convex surface is deformable if the surfaces that appear in the process of deformation must be convex. Pogorelov's uniqueness theorem, along with Alexandrov's sufficiency theorem, are outstanding achievements in geometry.

Many interesting related problems await the researcher. Some of them can be very simply formulated. For example, the problem of

regular development: Is it true that for every convex polytope one can find a way to cut it along its edges (none of its faces must be touched) so that the remaining surface can be developed, without self-intersections, into a planar region?

The problem is that each polyhedron has many different developments. Some of them are the results of cutting along the edges of the polytope without touching its faces. An example of a development of this sort is given in figure 8 (such developments are called *edgewise*). Let's call a *edgewise development* of a polytope *regular* if it consists of a single planar domain such that none of the faces of the polytope overlap. For instance, all edgewise developments of a tetrahedron are regular, but there are polytopes with as little as five faces, some of whose edgewise developments are not regular. For instance, take a truncated, regular triangular pyramid such that one of the planar angles in its lateral faces is greater than 100° (see problem M219 in the November/December 1997 *Quantum*). There are both regular and irregular edgewise developments of this polyhedron (fig. 10). So, the problem is: Does

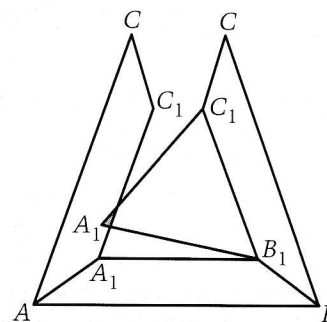

Figure 10

every convex polyhedron have a regular (edgewise) development?

To conclude, let's note that all the theorems mentioned herein were proved by mathematicians who were younger than 30 years old. Mathematics advances by the efforts of youth. New ideas, as a well-known mathematician said, are born in the heads of young geometers, but the old folks are still useful as "midwives." ◻

¹Olovianishnikov was a winner of the First Soviet Mathematical Olympiad (1934). The events of the next decade frequently left their mark on the difficult lives of talented young people. In 1941 Olovianishnikov graduated from Leningrad University and became a postgraduate student there. His scientific advisor was A. D. Alexandrov. World War II soon began, he volunteered to go to the front, and in autumn 1941 he was wounded. In the hospital he wrote his work generalizing Cauchy's theorem. He returned to the front and died in December 1941 in a furious battle in the Leningrad suburbs.

Why don't planes fly with cats and dogs?

An uplifting conversation in a downpour

by S. K. Betyaev

ONE WET AUTUMN NIGHT while my friend and I waited in the airport for our flight, we figured out for ourselves why planes can't fly in bad weather. It took us the better part of a day, but we did it. I even wrote down our adventure for posterity.

"Flight number 429 delayed due to weather conditions," said the voice on the loudspeaker. It was raining cats and dogs, and the streetlights were blurred in the dense air.

"Why are flights delayed in this weather?" I thought out loud. "The thunder and lightning are gone, wing icing doesn't happen in warm weather, and modern navigation devices can control flights even in zero visibility."

"Aha! I know why," I said after a long silence. "Airplane propellers aren't designed to work at such high humidity."

"Maybe you're an expert in propellers," my friend replied, "but ours is a jet plane. It isn't seriously affected by a little water in the engine."

"Then what's wrong? Is rainy weather just a pretext for other reasons?"

"Don't jump to conclusions. Let's draw how an airstream containing

water droplets flows around an airfoil."

Having moved his cup of coffee aside, my friend took a sheet of paper and some colored pens and quickly drew a sketch (fig. 1). Then

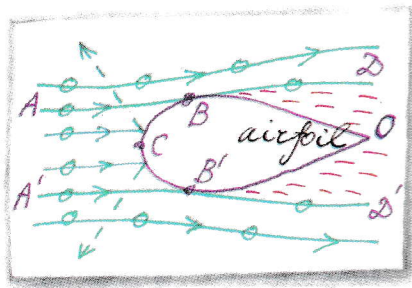

Figure 1

he said, "Let's consider the flight from the plane's frame of reference. In this dynamic frame of reference, the wing is at rest and the airstream with water droplets is incident to it. At large distances from the wing, the speed of the airflow equals the plane's speed from a ground-based frame of reference."

"What about the force of gravity?" I asked, looking at the sketch.

"It doesn't matter here. From the runway to the top of the rain clouds, the average speed of modern passenger planes is about 70 m/s. The speed of uniformly falling rain drops

is only 10 m/s. Therefore, we can neglect the force of gravity."

"Then how do the droplets hit the wing?"

"Well, let's consider this process. Among the trajectories of moving water particles, two are tangent to the boundary of the airfoil in our sketch [fig. 1]: ABD and $A'B'D'$. The trajectories that flow above ABD or below $A'B'D'$ do not hit the wing. The region colored red will be 'dry' because raindrops don't land there. By contrast, the site BCB' is continuously bombarded by drops. Each time a drop hits the wing, the drop's momentum changes, which means that it is affected by a force due to the wing. Therefore, a force of the same magnitude acts on the wing due to the drop. As you can see, this force is directed opposite to the plane's velocity. This is, how extra resistance is generated."

"So this force is the reason flights are cancelled during a heavy rain?"

"You're rushing ahead again," my friend cautioned. "Let's estimate this force. Meteorologists know that the heaviest rains are characterized by droplets with diameter $d \cong 2$ mm and density $\rho_d \cong 2$ g/m³. First, let's assume that the droplets don't deviate from their initial trajectories, so

Art by Pavel Chernusky

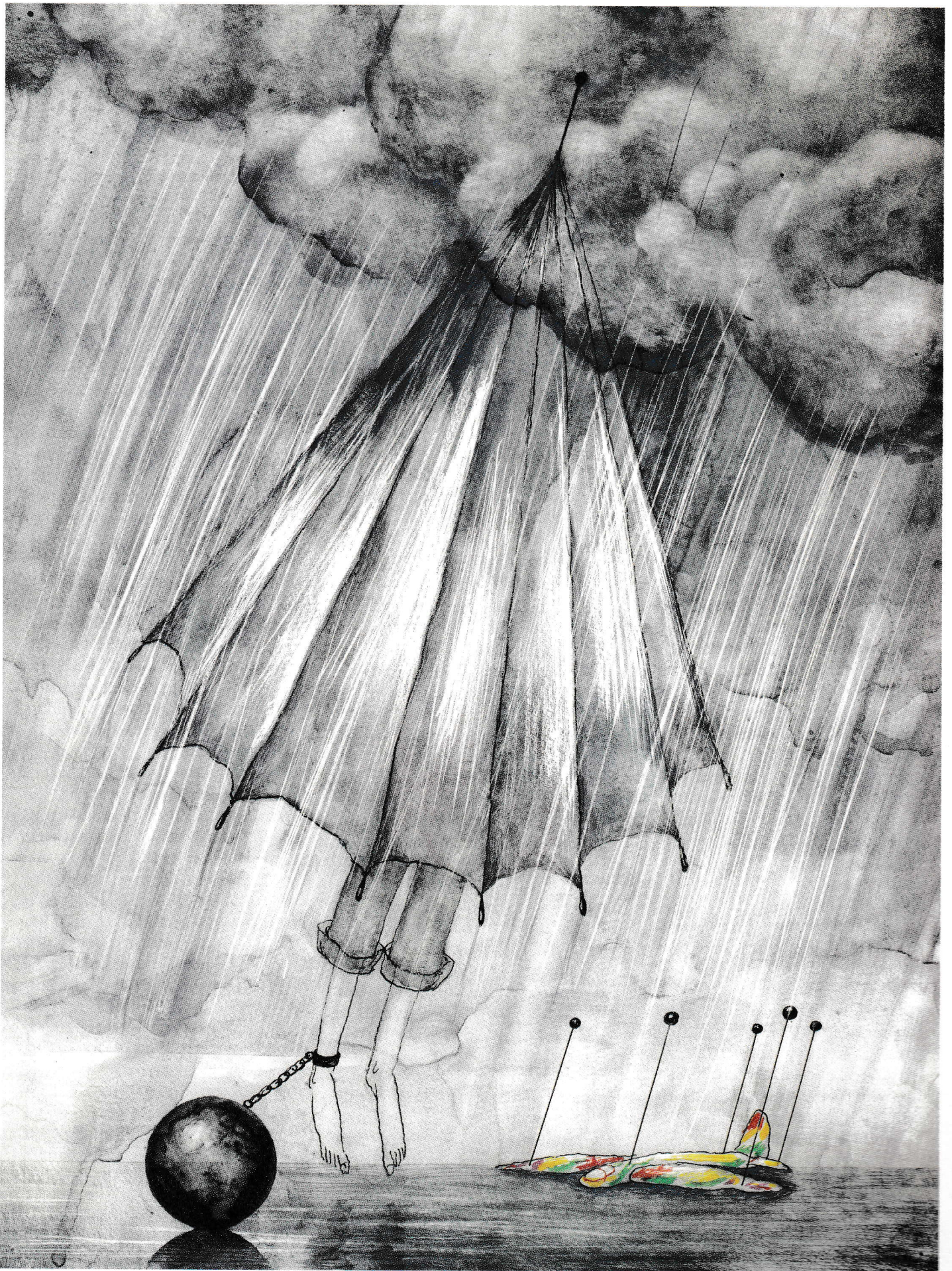

the lines ABD and $A'B'D'$ remain straight." (My friend drew the sketch in figure 2.)

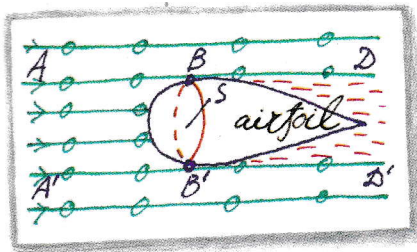

Figure 2

"In a unit of time the wing is hit by vSn number of droplets. Here S is the largest cross-sectional area of the airfoil perpendicular to the velocity (that is, it is the area of cross-section BB') and $n = \rho_d/m$ is the number of droplets in a unit volume. Provided that each droplet of mass m loses all its velocity in an inelastic collision with the wing, it imparts a momentum mv to the wing. Thus, all the incident droplets impart a momentum of approximately $vSnmv$ per unit time to the wing. By definition, this value is the force affecting the wing. It acts opposite to the direction of flight. Therefore, the air resistance is supplemented by a ram force F originating from the incident droplets, which is about $\rho_d Sv^2$.

The same formula is valid for the ram force of the droplet-free air, but in this case it deals with the density of air ρ_1 : $F_1 \cong \rho_1 Sv^2$. In standard conditions, $\rho_1 \cong 1300 \text{ g/m}^3$. Thus, the ratio of ram forces resulting from water droplets and air molecules will be about $F/F_1 \cong \rho_d/\rho_1 \cong 10^{-3}$.

"From these estimations we can see that the contribution of water droplets to the total ram force is very small. It is actually even smaller than what we've estimated, because the trajectories of the droplets near the wing deviate from the straight lines I've drawn, and the wing will not collide with every droplet aimed from infinity to the cross-sectional area S (as drawn in our sketch [fig. 1])."

"The rain can't impede the flight, then. So what's doing it?" I said, trying to guide the conversation back to our problematic flight.

"Be patient, my friend! You're

right. Collisions with water droplets don't hinder a flight. However, there is another force involved—the drag tangential to the wing's surface. Let's consider this force in detail. Clearly, the wing will be wet in rainy weather. This means that in heavy rain the wing will be surrounded by water, not air. In wet weather we can expect a profound increase in the resistance (drag) force." My friend drew a wing covered with a film of water (fig. 3).

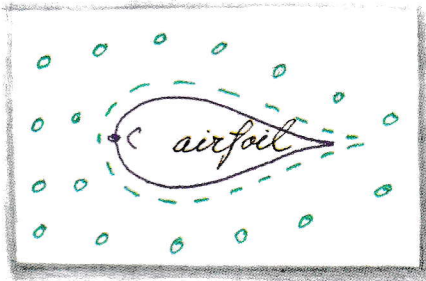

Figure 3

"But," I rejoined, "don't all machines, including planes, have extra power to cope with such problems?"

"That's true. But how much power is needed to overcome this additional drag? Let's do more estimations based on some new assumptions. It's natural to suppose that the speed of all water particles inside the film of water is not the same: It is zero at the wing's surface (here water 'sticks' to the wing), and it increases with the distance from the wing.

This behavior of the speed is explained by the forces of viscous friction in a moving liquid: Every thin layer of a moving liquid is affected both by the lower adjacent layer (located closer to the wing), where the viscous force is directed against the flow, and by the upper adjacent layer, where the viscous force is directed along the flow. When the viscosity of a liquid is low, the speed will reach its steady-state value v_0 at a very small distance from the wing. In other words, the viscous forces are important only in the thin boundary layer adjacent to the wing. Let's suppose that these very conditions are valid in our case." With this, my friend drew the sketch shown in figure 4.

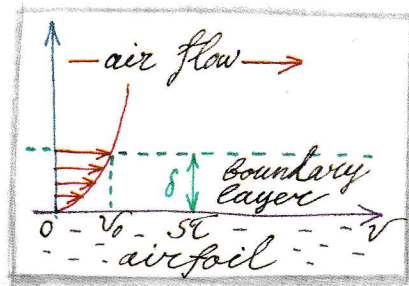

Figure 4

At this critical point I heard an announcement about our flight. We had been so engrossed in conversation that we didn't notice that the rain had almost stopped. Everybody around us was moving; it was not a time for scientific explication. When we were comfortably seated in the plane, I resumed the conversation.

"Let's clarify the wetness problem. You had stopped at the boundary layer."

"Oh, yes. Let's suppose that this boundary layer 'transmits' the force of the incoming flow to the wing, thereby producing the extra resistance. Then we can estimate the value of this resistance. We are interested in the force that acts tangential to the wing's surface. This force acting on a unit area is referred to as *specific drag*.

"It should be independent of speed," I guessed, "because by the condition of sticking, speed is zero at $y = 0$. Then what does specific drag depend on?"

"The answer to your question was given by Sir Isaac Newton in his *Principia Mathematica*: Specific drag τ is determined by the first derivative of the velocity $v(y)$ taken along the normal to the surface—that is, dv/dy . Friction is directly proportional to this derivative:

$$\tau = \mu \frac{dv}{dy},$$

where the proportionality factor μ is known as the dynamic coefficient of viscosity. This formula proved viable over a large range of values. Media that obey this relationship are called Newtonian. The media we're

interested in (air and water) are Newtonian."

"Let's say that this reasoning is correct. But we've just substituted one unknown value τ by another (dv/dy), so we haven't gotten anywhere."

"That's true. However, Newton's formula provides only a physical explanation of drag. The next step in finding the forces affecting the wing was made by the founder of boundary layer theory, a German hydrodynamicist named Ludwig Prandtl. In the boundary layer the action of frictional forces is essential, so it is natural to suppose that these forces decelerate the liquid. For the element shown in figure 4 it can be formulated as

$$m \frac{dv}{dt} \propto \tau s,$$

or

$$\rho \delta s \frac{dv}{dt} \propto \mu \frac{dv}{dy} s, \quad (1)$$

where δ is the characteristic thickness of the boundary layer, s the area of the element's base, $m = \rho \delta s$ its mass, and dv/dt the absolute value of the acceleration.

"But we've just added to the unknown values with the newcomer dv/dt ..."

"Actually, there's another one: The thickness of boundary layer δ is not a given parameter either. However, Prandtl could obtain an estimate for it. Let's follow his reasoning. Since equation (1) is an approximation, which means equality to an order of magnitude only, the first derivative can be replaced by the corresponding ratio. Thus, instead of dv/dy we can write v_0/δ . The equality $dv/dy = v_0/\delta$ will be correct only when the speed profile in the boundary layer is linear: $v = v_0 y/\delta$. In all other cases this formula is only an approximation, as is the original equation (1). Now let's estimate the value of dv/dt . The characteristic length where the boundary layer exists equals the span of the airfoil l_0 (the segment CO in figure 1). Therefore, we can suppose

$$\frac{dv}{dt} \propto \frac{v_0^2}{l_0}.$$

Canceling s from both terms of equation (1) and inserting the values of dv/dy and dv/dt , we get

$$\frac{\rho \delta v_0^2}{l_0} \propto \mu \frac{v_0}{\delta},$$

from which we get

$$\delta \propto \left(\frac{\mu l_0}{\rho v_0} \right)^{\frac{1}{2}},$$

or

$$\delta \propto l_0 \text{Re}^{-\frac{1}{2}}, \quad (2)$$

where the value $\text{Re} = \rho v_0 l_0 / \mu$ is called the Reynolds number. It's named after the English hydrodynamicist Osborne Reynolds, who was the first to discover the role of this dimensionless value in determining the type of flow. A liquid is considered low-viscosity if its Re is large. On the other hand, a liquid is high-viscosity when its Re is small. As we said before, the boundary layer is formed only in a low-viscosity liquid. In aviation, the range of Re numbers is $10^6 - 10^8$.

"Well, now the question on δ is clarified," I said after a pause, "but what we're interested in is τ , not δ . It's the value of τ that says whether or not the engine can develop the necessary thrust in wet weather."

"We can easily solve this problem with the help of equation (2) and by calculating the specific drag. At the bottom of the boundary layer we have

$$\tau \propto \frac{\mu v_0}{\delta} \propto \frac{\mu v_0}{l_0} \text{Re}^{\frac{1}{2}}.$$

"A similar relationship is valid for dry air flow. The respective 'air' values will be marked with the lower index value 1:

$$\tau_1 \propto \frac{\mu_1 v_{01}}{l_0} \text{Re}_1^{\frac{1}{2}},$$

where $\text{Re}_1 = \rho_1 v_{01} l_0 / \mu_1$. To deter-

mine by what factor the drag force is increased in rainy weather, let's consider the ratio τ/τ_1 . Taking into account the relationships between the quantities that determine τ and τ_1 , we get

$$\frac{\tau}{\tau_1} = \left(\frac{\rho}{\rho_1} \right)^{\frac{1}{2}} \left(\frac{\mu}{\mu_1} \right)^{\frac{1}{2}} \left(\frac{v_0}{v_{01}} \right)^{\frac{3}{2}}.$$

"The values of ρ , ρ_1 , μ , and μ_1 can be found in a textbook. But how can we determine the value of v_0/v_{01} ?"

"We can do it with the help of Bernoulli's equation. It provides the relationship between the velocity of fluid particles and pressure. In our case, the air flowing over the wing virtually moves in a horizontal plane, so the Bernoulli equation looks like this:

$$p + \frac{1}{2} \rho v^2 = \text{const.}$$

"It's not difficult to deduce this equation. Let's suppose that pressure varies in the direction of flow as $p(x) = kx + \text{const.}$ " (My friend drew the plot shown in figure 5.) "Outside

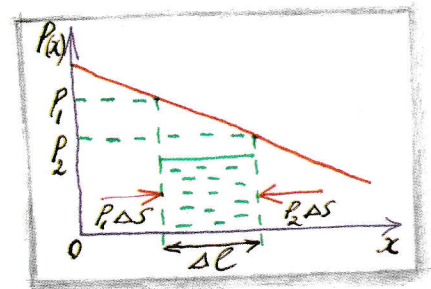

Figure 5

the boundary layer of a flow of fluid we consider a small parallelepiped with length Δl and lateral face area Δs . The left face of the parallelepiped is affected by the force $P_1 \Delta s$, and the right face by the force $P_2 \Delta s$. The total force affecting the marked parallelepiped is

$$F = P_1 \Delta s - P_2 \Delta s = (P_1 - P_2) \Delta s.$$

As

$$P_2 = P_1 + \frac{dP}{dx} \Delta l,$$

$$F = -\frac{dP}{dx} \Delta l \Delta s = -\frac{dP}{dx} \Delta V,$$

where $\Delta V = \Delta l \Delta s$ is the volume of the parallelepiped. The work performed by moving the parallelepiped along the x-axis is determined by

$$\int F dx.$$

When the transition is made from point $x = a$ to point $x = b$,

$$W = \int_a^b F dx = -\Delta V \int_a^b \frac{dP}{dx} dx \\ = \Delta V (P_a - P_b).$$

"On the other hand, this work is equal to the change in the parallelepiped's kinetic energy $W = K_b - K_a$ (here we neglect the work of frictional forces):

$$\Delta V (P_a - P_b) = \Delta V \rho \left(\frac{v_b^2}{2} - \frac{v_a^2}{2} \right),$$

from which we get

$$P_a + \rho \frac{v_a^2}{2} = P_b + \rho \frac{v_b^2}{2},$$

or

$$P + \rho \frac{v^2}{2} = \text{const.}$$

"Well that's settled," I said. "It's clear how to deduce Bernoulli's equation. Still, how can we determine v_0/v_{01} ?"

"With the same equation. It's valid for both liquid and gaseous flows. As we did before, mark the value with respect to air with the index value of 1. Thus, for the water film formed on the wing's surface we have

$$P + \rho \frac{v^2}{2} = \text{const.},$$

and for the air flow

$$P_1 + \rho_1 \frac{v_1^2}{2} = \text{const.}_1.$$

To compare v and v_1 , we need a relationship between const._1 , P , and P_1 .

"Remember that by comparing the ram forces for flights in dry and

wet weather, we discover that they are virtually identical. This means that the pressure at point C [in figure 1] can be considered identical in both cases. The speeds of liquid and air particles at this point are zero. Taking this into account, we can write the following formula for liquid flowing around a wing:

$$P + \rho \frac{v^2}{2} = P_C.$$

And for the air flow, we have

$$P_1 + \rho_1 \frac{v_1^2}{2} = P_C.$$

Therefore,

$$P + \rho \frac{v^2}{2} = P_1 + \rho_1 \frac{v_1^2}{2}.$$

"Now let's settle the question of P and P_1 . The selected parallelepiped moves with the flow virtually in the horizontal direction. That is, its vertical velocity is zero. Thus, the forces acting on it from above and below are equal. However, in both cases (with and without the water film) the force which acts from above is the pressure acting from the 'outer' air flow. Thus, both 'air' and 'liquid' parallelepipeds are affected from below by identical forces. Therefore, the existence of a thin water film doesn't affect the vertical distribution of pressure, and the values of pressure are equal in the same cross-section of water and air flow: $P = P_1$.

"Now I see," I interrupted my friend. "It follows from the condition $P = P_1$ that

$$\frac{\rho v^2}{2} = \frac{\rho_1 v_1^2}{2}.$$

Therefore

$$\frac{v}{v_1} = \left(\frac{\rho_1}{\rho} \right)^{\frac{1}{2}}.$$

Finally, we inferred that when the rain is rather heavy, the drag force affecting the wing is increased by a factor of

$$\frac{\tau}{\tau_1} = \left(\frac{\rho_1}{\rho} \right)^{\frac{1}{4}} \left(\frac{\mu}{\mu_1} \right)^{\frac{1}{2}}.$$

The voice on the loudspeaker informed us that our plane had landed. I put in my pocket the notes my friend had given me.

At home I looked in some reference books and found all the necessary values of density and dynamic viscosity for water and air. Plugging them into the last formula, I got $\tau/\tau_1 \cong 1.5$. Therefore, an "all-weather" plane must have an extra thrust force of 50 percent compared with a normal aircraft. This is why planes don't fly when it's raining cats and dogs.

We obtained this estimate by supposing that there is an aqueous boundary layer on the wing's surface surrounded by air. A question comes to mind: What thrust force should an engine have to propel an airplane in a continuous flow of water? I challenge you to solve the problem on your own. Here's the answer: To transform an airplane into a submarine, the power of its engine should be increased by a factor of

$$\frac{\tau}{\tau_1} = \left(\frac{\rho}{\rho_1} \right)^{\frac{1}{2}} \left(\frac{\mu}{\mu_1} \right)^{\frac{1}{2}} \cong 230. \quad \blacksquare$$

Quantum articles on fluid mechanics:

S. Betyaev, "Hydroparadoxes," July/August 1998, 20-24.

L. Guryashkin and A. Stasenko, "The history of a fall," March/April 1995, 10-15.

S. Kuzmin, "Spinning in a jet stream," September/October 1994, 49-52.

L. Leonovich, "Fluids and gases on the move," January/February 1996, 28-29.

A. Mitrofanov, "Against the current," May/June 1996, 22-29.

J. Raskin, "Foiled by the Coanda effect," January/February 1994, 5-11.

H. Schreiber, "A viscous river runs through it," November/December 1995, 43-46.

A. Stasenko, "Whirlwinds over the runway," July/August 1997, 36-39.

I. Vorobyov, "Anopies and bottom-flowing streams," July/August 1995, 45-47.

Just for the fun of it!

B241

Natural trio. Sam says he knows three natural numbers x , y , and z that satisfy the equation $28x + 30y + 31z = 365$. Is he right?



B242

Short fuse. You have two pieces of fuse, each of which burns in 1 minute. Use these pieces of fuse to time 45 seconds. You may not use scissors, and the rate of burning may vary along the fuse.

B243

Disappearing commas. A student wrote three natural numbers on the blackboard that are consecutive elements of an arithmetic progression. Then he erased the commas between them, creating a seven-digit number. What is the maximum possible value of this number?

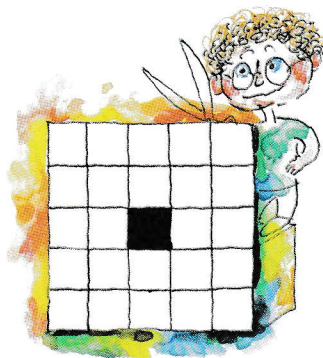

B244

Cube assembly. The central square is cut from a 5×5 grid. Cut the resulting figure into two parts such that they can be folded into a cube with an edge length of 2 squares.

B245

Retreating reflection. Once my son and I rowed a boat on a lake. The forest was reflected beautifully in the calm surface of the water. My son said, "Let's sail over the reflection. I want to see it under my feet!" We tried to do so but failed: The reflection always "ran away." Why?



ANSWERS, HINTS & SOLUTIONS ON PAGE 54

Art by Pavel Chernusky

Euclidean complications

What's true locally according to Euclid may not remain valid as we travel further afield

by I. Sabitov

THE GEOMETRY WE STUDY at school is called Euclidean in honor of the ancient Greek who used the axiomatic method to systematize this science. Among the axioms formulated by Euclid in his *Elements*, the fifth postulate—the *parallel postulate*—has become the best known. Essentially this postulate states that for any point not on a given line, there is a unique line passing through the given point that is parallel to the given line. In the *Elements*, this postulate was formulated in a different, though equivalent, way: *If a line intersects two other lines and forms interior angles on one side of the line whose sum is less than two right angles, then these two lines meet at the side where the sum of the angles is less than two right angles.*

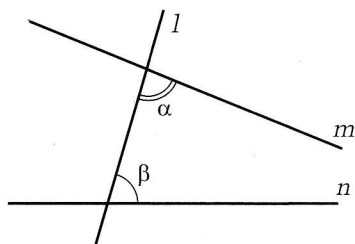

Figure 1. In the figure, if $\angle a + \angle b < 180^\circ$, then lines *m* and *n* will intersect to the right of line 1.

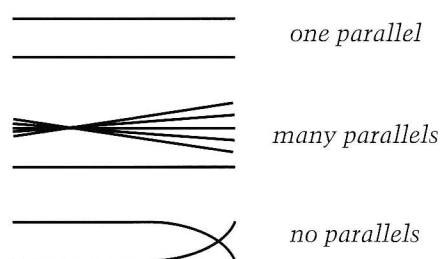
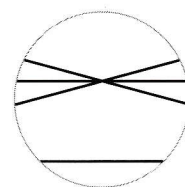

Figure 2. In Euclidean, Lobachevskian, and Riemannian geometries, different parallel axioms are used.

However, Euclidean geometry is not the only logically possible one: non-Euclidean geometries exist in which the parallel axiom is quite different. If we start with a line, and a point not on it, we can make different assumptions about the existence of lines parallel to the given line and passing through the given point. Assuming that there are at least two such lines leads to the geometry named after the great Russian mathematician N. I. Lobachevsky.¹ Yet

¹You can read the instructive and dramatic story of the discovery of non-Euclidean geometry, in which K. F. Gauss and J. Bolyai took part in addition to Lobachevsky, in the November/December 1992 issue of *Quantum* ("The Dark Power of Conventional Wisdom" by A. D. Alexandrov).



How many parallels?

Figure 3. In a limited part of the space, we cannot tell immediately which of the parallel axioms is valid.

another axiom—that *there are no lines passing through a given point not on a given line that do not meet this given line*—leads to Riemannian (or elliptical) geometry (see figure 2).

Which of these three logically possible geometries—Euclidean, Lobachevskian, or Riemannian—is true in our real physical world?

It's not easy to come up with a quick answer to this question. It's not clear how the parallel axiom can be verified experimentally. The fact is, we can extend a line infinitely long only theoretically. In practice, even the best telescopes can reach only a limited part of the Universe. Moreover, as we can see from figure 3, many lines in the given plane pass through the given point and do not meet the given line within the do-

Art by Yuri Vashchenko

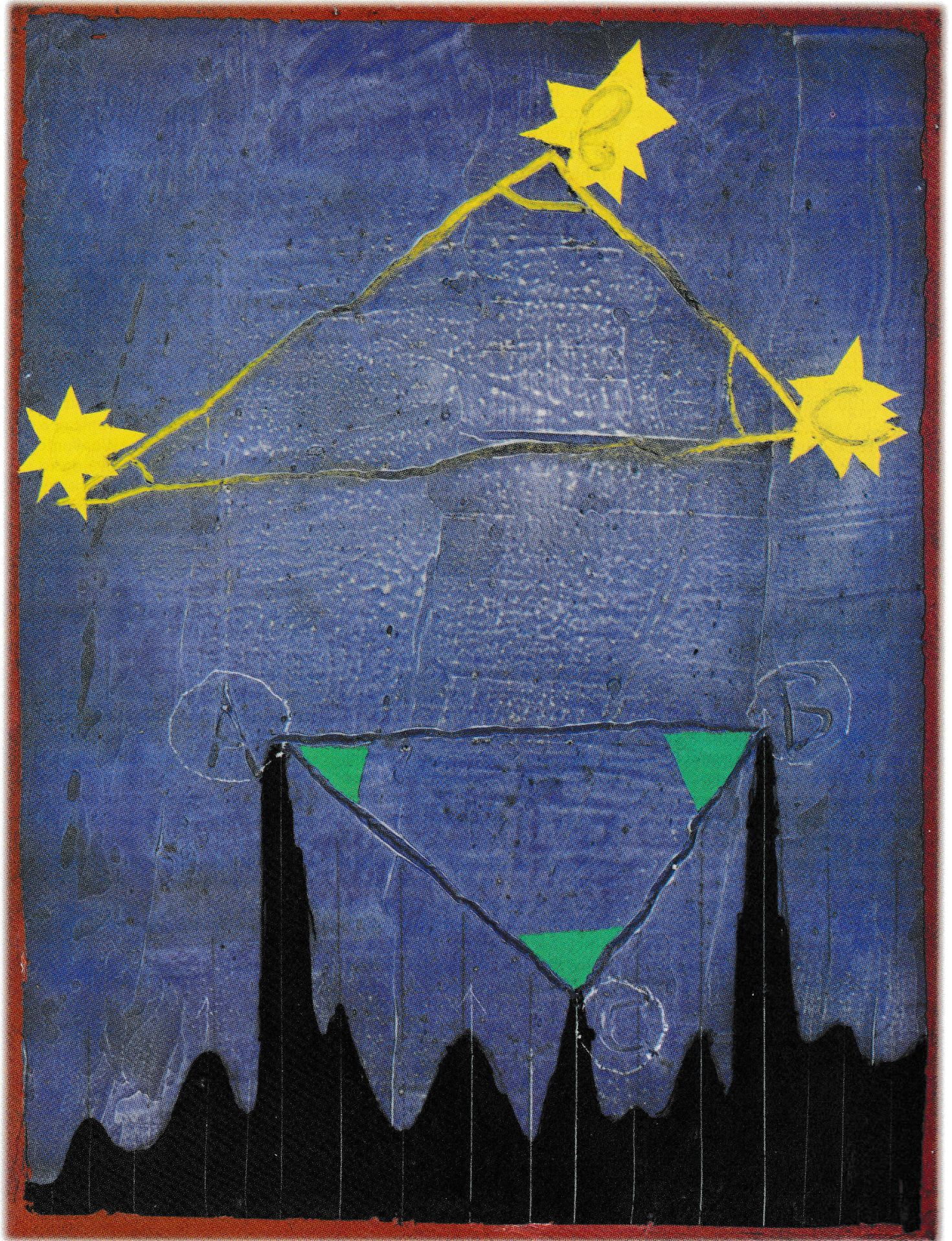

main available for observation (even if the fifth postulate is valid).

So—how can we verify the parallel axiom?

The cornerstone of geometry?

It turns out that it is possible, in principle, to verify the parallel axiom. This axiom is equivalent to the proposition that the sum of the angles of any triangle is 180° ; ² in Lobachevskian geometry, this sum is less than 180° . Gauss tried to use geodetic measurements to calculate the sum of the angles of a triangle formed by three summits in the Hartz Mountains (Brocken, Hohenhagen, and Inselberg) located about 100 km from one another. Lobachevsky, on the other hand, chose cosmic distances for his calculations: he measured the sum of the angles of the triangle formed by the Earth, the Sun, and Sirius, the brightest star in the northern skies. But in both experiments the deviation from 180° turned out to be less than the possible error of the measurements, so no definite conclusion about the geometry of the real world could be drawn.

However, let's assume that some observer has managed to establish with faultless accuracy that the sum of the angles of a triangle is 180° . Does this mean that the geometry of our world is Euclidean?

The answer is yes if we agree that Legendre's theorem is valid (see footnote 2). However, this theorem is proved by means of other Euclidean axioms. The question is, are these other axioms valid in the real world? For example, how can we be sure that two lines that intersect on a sheet of paper never meet again in real space, if they are extended to an arbitrary distance? We need to be equally demanding with all of Euclid's axioms—we won't assume in advance that if an axiom is true within a limited domain, it's also true in all of space.

²Moreover, the French mathematician A. Legendre proved that the parallel axiom is true if there exists at least one triangle the sum of whose angles is equal to 180° .

So we arrive at the following question: assuming that Euclid's axioms are true "locally" everywhere in "real space"—that is, within the reach of our instruments (wherever the observer is situated); is it true that real space is Euclidean on the whole? In other words, is all of Euclidean three-dimensional space an adequate model of all of physical space? This important (in essence, cosmological) question is open to a purely mathematical formulation, which will be the focus of this article.

Statement of the problem

Let all the propositions of Euclidean geometry be valid in the neighborhood of every point in space (say, in a sphere whose center is this point). Naturally these propositions must be formulated in such a way that they make sense inside the sphere—for example, the parallel axiom must be replaced with the proposition that the sum of the angles of a triangle equals 180° , and so on. What can we say about the geometry of space as a whole?

A space that is Euclidean in a neighborhood of every point is called *locally Euclidean*.

Here is a mathematically more correct definition of locally Euclidean space. Two sets A and A' in each of which the distance between every pair of points is defined are called *isometric* (from the Greek words ισος , which means equal, and μετρον , which means measure or length) if there exists a one-to-one correspondence between their points that preserves distance. This means that the distance $|ab|$ is equal to $|a'b'|$ for any points $a, b \in A$ if a' and b' are the corresponding points from A' . A space is called *locally Euclidean* if a distance is defined between every two points in it, and if each point has a neighborhood that is isometric to a sphere in ordinary Euclidean space.

In this article it won't be possible to examine locally Euclidean three-dimensional spaces. We'll restrict ourselves to locally Euclidean two-

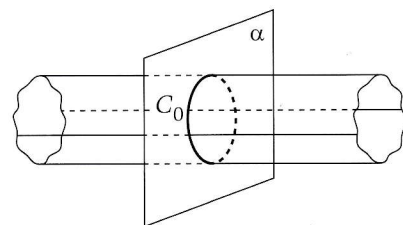

Figure 4. Infinite cylinder.

dimensional spaces. Such spaces will be called *locally Euclidean planes*. Our problem can be formulated as follows. How do locally Euclidean planes look in the whole of space?

The cylinder and its development

The Euclidean plane itself is naturally the simplest example of a locally Euclidean plane. We won't dwell on this case, but move on to another rather simple example—the *infinite cylindrical surface*, or just the *cylinder*. Figure 4 shows this surface as the set of all points of horizontal lines (generators) passing through all possible points of the unit circle C_0 (directrix) lying in the vertical plane α .

However, we don't have any "geometry" on the cylinder yet. We must define a distance between points, determine what is meant by "straight lines" on the cylinder, and so on. To introduce these definitions, we cut the cylinder C along one of its generators and develop it onto the coordinate plane Oxy as an infinite strip Π whose points (x, y) satisfy the inequality $0 \leq y \leq 2\pi$ (see figure 5). We will assume that the

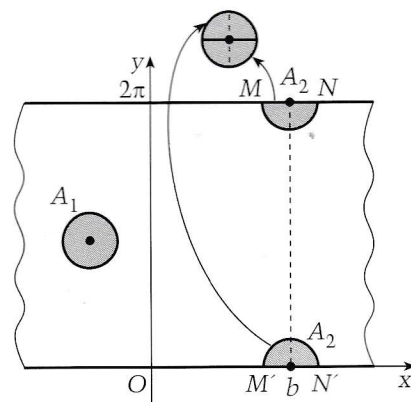

Figure 5. The cylinder (a ribbon with two sides identified) is locally Euclidean.

plane strip Π with its edges "glued together" (that is, if all pairs of points $(b, 0)$ and $(b, 2\pi)$ are considered identical) defines the geometry on the cylinder. Mathematicians say that we *identify* the pairs of points of the form $(b, 0)$ and $(b, 2\pi)$ for all b and consider the geometry on the strip Π using this identification.

Let's verify that this geometry on the cylinder is locally Euclidean. Consider an arbitrary point $A(x, y) \in \Pi$. If the point $A = A_1$ is not on the edge of the strip (fig. 5), everything is clear. Consider a circle of a radius r less than the distance from A to the nearest edge. This circle is entirely in the strip Π and, naturally, is an ordinary Euclidean circle. If the point $A = A_2$ is on the edge of the strip (fig. 5), then its coordinates are of the form $(b, 0) \equiv (b, 2\pi)$. In this case, the union of two unit semicircles (glued together!) with the centers at the points $(b, 0)$ and $(b, 2\pi)$ can be considered a circular neighborhood of this point $A = A_2$. Since the semicircles are glued on their diameters $MN \equiv M'N'$, we obtain an ordinary Euclidean unit circle after the gluing.

On the cylinder C , it would be natural to define the distance between two points as the length of the shortest line connecting these points and lying on C . We could develop another geometry on this basis. An alert reader might ask whether this geometry coincides with the geometry of the strip Π with identified edges. It turns out that it does. However, the proof of this fact, which is related to what is called *differential geometry*, is beyond the scope of this article.

Geometry on the cylinder

We've established that the geometry of the cylinder is locally Euclidean. How does the geometry of the cylinder (that is, of the strip Π whose edges are identified) look in the larger context? How is "distance" on the cylinder measured? What are its "straight lines"? Which axioms are valid?

Before answering these questions, let's consider a rather unusual ex-

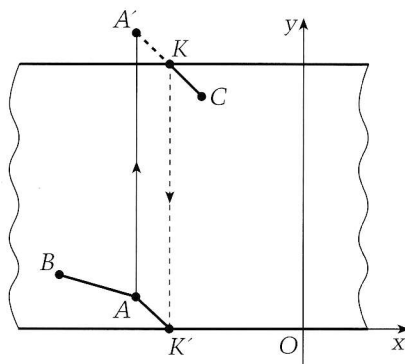

Figure 6. The shortest distance between points A and C is $|AK'| + |KC|$.

ample. Think of a kingdom with two parallel roads, with rest stops located at short intervals along these roads (there may be other roads in the kingdom as well). The rest stops that are opposite one another on different roads are connected by telephone lines, but there is no telephone communication between adjoining rest stops on the same road. Set the distance between two points equal to the minimal time needed to transmit a message between these points. Suppose we want to get a message from point A to point B somewhere in the kingdom. While there may be a road from A to B , a courier may do better to run not directly from A to B , but toward the nearest telephone booth (and perhaps even in the opposite direction).

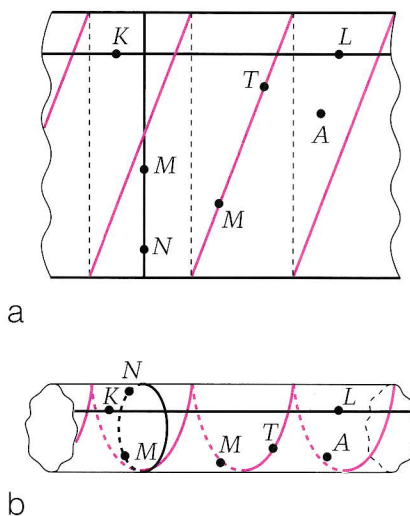

Figure 7. Three types of "straight lines" on the cylinder: the spiral line ST , the straight line KL , and the circle MN .

The same unusual distance exists on our strip with identified edges. Indeed, consider the points A , B , and C on the strip Π (see fig. 6). For two points A and B whose y -coordinates y_A and y_B differ by less than half of the width of the strip Π , the distance is the usual one—that is, the length of the segment AB . However, for points A and B for which $|y_A - y_B| > \pi$, the distance is equal to $|AK'| + |KC|$, where A' is obtained from A by translation upward by the vector $\overrightarrow{AA'}$ of length 2π , K is the point of intersection of the segment CA' with the edge of the strip, and $\overrightarrow{KK'} = -\overrightarrow{AA'}$ (fig. 6). In the language of the telephone example, it's more advantageous to send a courier from C to K , then transmit the message instantly to K' over the phone, and then send it with another courier along the segment $K'A$ to point A .

Problem 1. Prove that the distance from point $A(x_A, y_A)$ to point $B(x_B, y_B)$ in a strip with identified edges is given by the formula

$$|AB| = \begin{cases} \sqrt{(x_A - x_B)^2 + (y_A - y_B)^2} & \text{if } |y_A - y_B| \leq \pi, \\ \sqrt{(x_A - x_B)^2 + (2\pi - |y_A - y_B|)^2} & \text{if } |y_A - y_B| > \pi. \end{cases}$$

"Straight lines," as well as distances, are peculiar in our geometry. They can be of three kinds (see fig. 7a). First, any ordinary line parallel to the edges of the strip is a straight line. Second, any segment connecting the edges with the identified endpoints that is perpendicular to the edges is a "straight line." Third, the set of oblique parallel segments, such as that shown in figure 7a, is a "straight line." On the cylinder, these three kinds of straight lines are generators of the cylinder, circles parallel to the directrix, and spiral lines, respectively (see fig. 7b).

As for the axioms, notice that the parallel axiom holds in the larger context (that is, on the entire surface)!

Problem 2. Find the unique "straight lines" that are parallel to

the “straight lines” KL , MN , and ST passing through point A in figures 7a and 7b.

But now other Euclidean axioms are violated—even the axiom stating that there is a unique line passing through two points. For example, the red (spiral) “straight line” meets the black line (generator) infinitely many times (fig. 7)!

Problem 3. Describe all pairs of points on the cylinder through which only one straight line passes.

However, these examples don’t exhaust the peculiar properties of cylindrical geometry. You probably have already noticed that the “straight lines” on the cylinder that are parallel to the directrix are bounded: the maximum distance between points on such a line is equal to π .

Problem 4. Give examples that show that a straight line segment is not always the shortest route between its endpoints, a slanting line can sometimes be shorter than the perpendicular, and that the Pythagorean theorem is not always true. Determine what a “circle”—a set of points equidistant from a given point—looks like as the radius of the circle increases.

We see that the local validity of all axioms of Euclidean geometry, and even the validity of the parallel axiom in the larger context, doesn’t ensure that a world with this geometry is an infinite plane. Such a world can be structured as an infinite cylinder and, as we will now see, as other geometrical structures.

The flat torus

Let a rectangle T with vertices A , B , C , D be given in the plane Oxy (fig. 8). Let AB have length $2b$ and let CD have length $2a$. Let’s identify the side AB with the side CD such that A is identified with D and B is identified with C . Next we identify the side BC with the side AD such that B is identified with A and C is identified with D . (With such an identification, all the vertices of T are merged into one point.) We define the distance between two points of the rectangle as the length

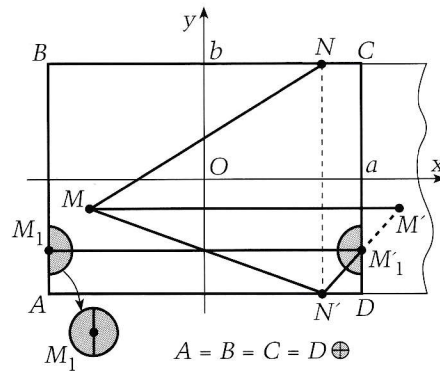

Figure 8. The flat torus is a “glued” rectangle. The shortest distance between points M and N is $|MM_1| + |M_1N|$.

of the shortest path between these points, taking into account the identifications made.

We introduce a coordinate system as shown in figure 9, with the origin at the center of the rectangle. Let’s calculate, for example, the “distance” between the points $M(-\frac{3}{4}a, \frac{1}{4}b)$ and $N(\frac{3}{4}a, b)$ (fig. 8). First, notice that the segment MN' , where $N'(\frac{3}{4}a, -b)$, is shorter than MN . Therefore, we must look for the shortest path from M to N among the paths that connect M with N' (since N' and N are considered one and the same point). The region to the right of segment AB is identical, under our construction, to the region to the right of segment BC . Setting the strip $a \leq x < 2a$, $-b \leq y \leq b$ against side DC (fig. 8), we can see that any other path from M to N' , including the segment MN' , is longer than the segment $M'N'$. Thus the shortest path from M to N is the union of the segments MM_1 and M_1N' , and the “distance” between M and N is $\sqrt{(a/2)^2 + (3b/4)^2}$.

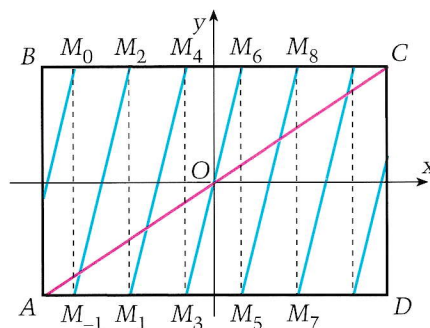

Figure 9. Two “straight lines” (red and blue) on the torus.

Problem 5. (a) Give examples of pairs of points with the distance $\sqrt{a^2 + b^2}$ between them. (b) Prove that the distance between any two points cannot be greater than $\sqrt{a^2 + b^2}$. (c) Prove that for any given point there exists a unique point that is at a distance $\sqrt{a^2 + b^2}$ from it.

The rectangle T whose pairs of opposite sides are identified, resulting in the rule for calculating distances described above, is called the flat torus.

“Straight lines” on the flat torus are defined in the same way as on the strip Π , which is a model of the cylinder. Figure 9 shows two “straight lines”: the red closed “straight line” AC consists of one Euclidean segment; the blue “straight line” consists of many segments— $\dots M_{-1} (= M_0)M_2 (= M_1)M_4 (= M_3)\dots$ —and it may possibly close when extended further.

Problem 6. Prove that a “straight line” on the flat torus is closed if and only if the number $(a \tan \alpha)/b$ is rational, where $\tan \alpha$ is the slope (with respect to the axis Ox) of the segments in T that constitute this line.

We assert that the geometry of the flat torus thus constructed is locally Euclidean. Indeed, any interior point of the rectangle T has a small neighborhood in which all objects and rules for measurement that were introduced for the flat torus are the same as in Euclidean geometry. For a point M_1 on the boundary, the proof can be gleaned from figure 8. For the vertices, this is evident from the same figure: all neighborhoods of the four identified vertices have been carried to one point via the identification rule, and the geometry around this point turns out to be the geometry of the Euclidean circle.

Thus the flat torus provides another example of a locally Euclidean world. Here, as in the case of the cylinder, the fifth postulate is valid in the larger context. However, the structure of the torus in this larger context differs from that of the ordinary plane and the cylinder.

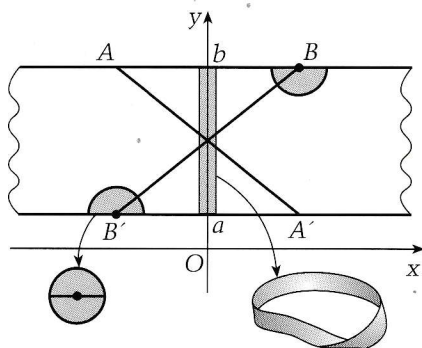

Figure 10. Infinite Möbius strip.

Problem 7. Prove that there are no arbitrarily long distances on the flat torus, although arbitrarily long straight lines do exist. Analyze the shape of the “circle” on the flat torus as its radius increases.

The flat torus is different from the cylinder in another important way. In gluing the strip Π to create a cylinder, the lengths of curves in Π are preserved. The flat torus, however, cannot be represented as a surface in three-dimensional space with the lengths of all its curves preserved. However, this difference is called an *external difference*, since it becomes clear only when we try to relate the geometry of the strip Π or the rectangle T with the geometry of a surface in a space that is external to them. If we assume that the rectangle T is made of rubber and allow it to be extended, it's possible to make a torus out of it.

The infinite Möbius strip

Let's take another look at the infinite strip Π , $a \leq y \leq b$, $-\infty < x < +\infty$, but this time we identify the edges of Π according to the following rule: the point (x, a) is identified with the point $(-x, b)$ (that is, the line $y = b$ is first mirror-reflected about the axis Oy and then is identified with the line $y = a$). The definitions of “distance” and “straight line” are similar to those for the cylinder and flat torus. The locally Euclidean plane constructed in this way is called the *infinite Möbius strip* (the ordinary Möbius strip is a part of the infinite one and is obtained by gluing a finite vertical strip such as the shaded one in figure 10). Figure 11 shows three “straight lines”: the black one,

which is closed; the blue one, which is parallel to the edge of the strip Π ; and the red one, which is slanted and consists of an infinite number of Euclidean segments. Using point B as an example (fig. 10), we can see how the identification rule generates a Euclidean geometry in the neighborhood of an edge point of Π .

Problem 8. Analyze the geometry of the infinite Möbius strip. Prove that each slanted line intersects itself an infinite number of times. Is the fifth postulate valid in the larger context? What do circles look like?

The flat Klein bottle

Let's return to the rectangle in figure 8. We'll introduce the following rule of identification: the side AD is identified with BC with the order of the points preserved—that is, the point $(-a, y) \in AD$ is identified with the point $(a, y) \in BC$. The side AB is identified with CD with the order of the points reversed—that is, the point $(x, -b) \in AB$ is identified with the point $(-x, b) \in CD$. In particular, all the vertices are considered one point. “Straight lines” and the rules for measuring “distances” are the same as before. Again, it can be verified that in a neighborhood of each point, we obtain a Euclidean geometry (perform this verification for a neighborhood of the rectangle's vertex). This model of locally Euclidean geometry is called the *flat one-sided torus* or the *flat Klein bottle*.

Problem 9. Analyze the geometry of the flat Klein bottle.

As with the flat torus, the Klein bottle cannot be placed into three-dimensional space without distorting distances. Moreover, it can be

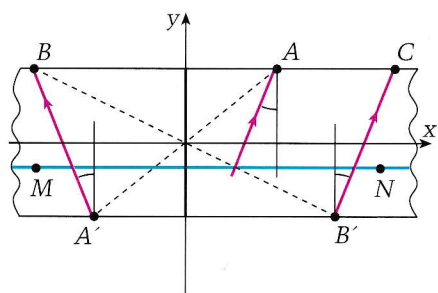

Figure 11. Straight lines on the infinite Möbius strip: black (vertical), blue (MN), and red ($A'B$).

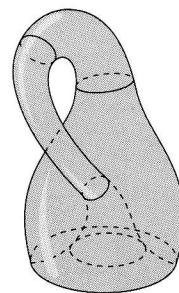

Figure 12. A model of the Klein bottle (with self-intersection).

placed into that space only with self-intersections, even if we allow stretching and compressing (without breaks). A model of the Klein bottle with self-intersection is shown in figure 12.

Euclidean worlds

The principle of “equal demands” on all axioms has certainly justified itself. We found that the Euclidean geometry of the plane is not based exclusively on the parallel axiom, but that other axioms help determine its properties. Moreover, it turns out that even if a neighborhood of every point is Euclidean and the fifth postulate holds in the larger context, this doesn't necessarily mean that the space is Euclidean on the whole (the cylinder and flat torus provide examples). Thus if the geometry turns out to be Euclidean in all the separately examined parts of space, the Universe on the whole is not necessarily so simple as the two-dimensional plane or three-dimensional space.

In higher geometries, it is proved that there are no complete locally Euclidean “worlds” other than the five examples mentioned above—the plane, cylinder, flat torus, infinite Möbius strip, and flat Klein bottle. (Roughly speaking, “completeness” means that every “straight line” can be extended infinitely, even if only along itself.)

As for three-dimensional locally Euclidean spaces, there are 18 types. Here we mention only one example: the layer of space between two parallel planes identified at points that are symmetric about the middle plane in the layer. ◻

Sound power

The nature and uses of intense acoustic waves

by O. V. Rudenko and V. O. Cherkezyan

“STOP!” ORDERED THE captain, and the submarine stood still at once. “Aim!... Sound!”

In the first minute nothing changed in the cruiser's outline. The ultrasonic gun operated at point five of its power. Then suddenly... the underwater part of the cruiser amidships began to stretch and tear apart like clay. One minute after the commencement of the ultrasonic attack, the middle of the ship's side facing the submarine suddenly was compressed, and several seconds later cracked like a giant bubble, and a formidable stream of water burst into the holds, engine room, and ammunition rooms.

This is a passage from the once popular science fiction novel of G. Adamov *The Mystery of Two Oceans*. The personages of this novel circumnavigate the world aboard the experimental submarine *Pioneer*—a miracle of military technology. Both submarine and scuba divers were equipped with ultrasonic guns, which many times helped them in critical moments. With the help of powerful ultrasonic waves the aquanauts tried to destroy the rock blocking the exit from an undersea cave; they killed a huge

sperm whale, which almost sunk the whalers who harpooned it; moreover, they destroyed a hostile cruiser and even the fantastic marine monsters that kidnapped one of the sailors.

You may think these details superfluous, but remember that this novel was published just before World War II, and at that time one could think that ultrasonic arms were possible and could be produced after solving some technical problems. However . . .

In this article we consider some problems of ultrasound physics and, in particular, we'll show why powerful acoustic waves cannot be used as a military weapon. So Adamov's novel is pure fancy, at least at this point. By contrast, the list of “peaceful” applications of ultrasonic waves is quite impressive: ultrasonic imaging, parametric radiators and antennas, ultrasonic surface cleaning, hole drilling, and kidney stone therapy, to name just a few.

In recent decades great advances have been made in our understanding of large-amplitude waves in general and ultrasonic waves in particular. What do we know about such waves today?

Previously, *Quantum* described

some interesting phenomena associated with large waves on the ocean surface.¹ Let's recall what was said there: The effects that accompany only waves that are intense enough and depend on their amplitude are called nonlinear. There is a field of science, nonlinear wave physics, that studies these phenomena. The subfield of physics that studies intense acoustic waves is called “nonlinear acoustics.” This science plays a particular role in physics due to the large variety of phenomena under investigation. Nonlinear waves are generated in fluids, solid bodies, and plasmas. They exist in nature in the atmosphere, ocean, soil, and also in space objects. Examples include thunder, seismic waves from earthquakes, and a number of other phenomena.

Several natural questions may occur to readers at this point:

- What is intense sound and what is weak sound, and where is the demarcation line between them?
- What are nonlinear effects, what is unexpected and extraordinary in them, and what are their applications?

¹Ivan Vorobyov, “The Bounding Main,” May/June 1994, pp. 20–25.

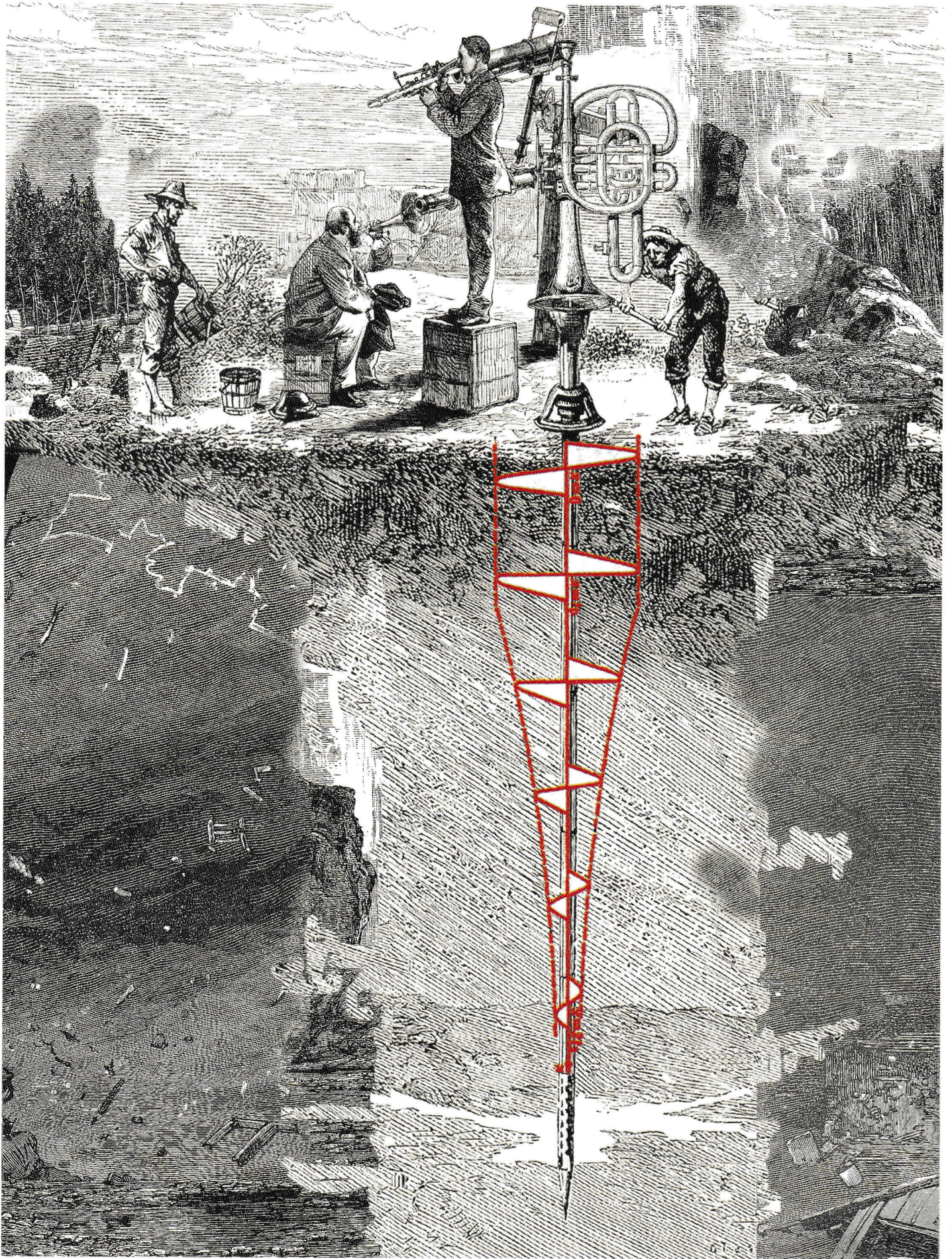

We will try to answer these questions one by one. First of all we recall what a sound wave is. A sound wave is composed of traveling vibrations of a medium, which are successive points of high (compression zones) and low (rarefaction zones) pressures. Sustained pressure oscillations caused by changes in compression occur in every point of the medium. The pressure variations are superimposed with the mean pressure (existing in the medium in the absence of sound waves) to find the (net) acoustic pressure.

A sound wave carries energy—the potential energy of elastic deformation (when sound is propagated in the atmosphere, this is the energy of air elastic deformation) and the kinetic energy of moving particles. The energy is carried in the same direction as the progress of the wave. The flow of energy—the amount of energy passing perpendicularly through a unit area per unit time in the direction of the wave propagation—characterizes the intensity of the sound wave.

Clearly, both the intensity I and the acoustic pressure P depend on the characteristics of the medium through which the sound wave travels. We will not deduce the respective formulas but rather will give the formula that describes the intensity I in terms of the density ρ and the sound velocity c (in the particular medium):

$$I = \frac{P_0^2}{2\rho c}$$

where P_0 is the amplitude of the acoustic pressure.

Now let's consider what is "strong" and what is "weak" sound. The intensity of sound is measured in terms of decibels (dB), which are related to the amplitude of the acoustic pressure:

$$\beta = 20 \log (P/P_{\text{thr}}) \text{ dB.}$$

Here P is the pressure we are interested in, P_{thr} is the threshold of acoustic pressure, conventionally accepted to be $2 \cdot 10^{-5}$ Pa. The pressure P_{thr} corresponds approximately

to the intensity $I_{\text{thr}} = 10^{-12}$ W/m² of a very weak sound, which can be perceived by humans at a frequency of 1000 Hz.

The greater the acoustic pressure, the louder the sound. Our subjective impression of sound intensity is related to the notion of "volume," so it is connected with a certain frequency range characteristic of the human ear (see Table 1). What should we do when the sound frequency lies outside of this range and corresponds to ultrasound? At these frequencies of about 1 MHz, it is most simple to observe the nonlinear sound effects in the laboratory conditions. Thus, an intense wave is one in which nonlinear phenomena become pronounced.

Now let's consider these nonlinear effects. The usual (linear) sound wave is known to travel in a medium without changing its shape.

The zones of compression and rarefaction propagate with the same speed, which is the speed of sound. If the source of sound generates, say, a sine wave, its profile will remain sinusoidal at any distance from the source.

By contrast, in an intense sound wave the compression zones (acoustic pressure positive) travel at a larger speed than the sound, and the rarefaction zones travel at a smaller speed than the sound (in the given medium). As a result, the wave profile is distorted: The wave front becomes steeper and the trailing edge flattens.

Similar phenomena can be observed in ocean waves. At a shoal, the smooth waves sharpen their front steeply before breaking in the surf area. Formation of a steep wave front or a breaker is a nonlinear phenomenon. The distance l_b , over

Intensity level (dB)	Intensity of sound (W/m ²)	Acoustic pressure (Pa)	Perception and sound source
0	10^{-12}	$2 \cdot 10^{-5}$	threshold of audibility
10	10^{-11}	$6.3 \cdot 10^{-5}$	rustle of leaves in a forest; a weak whisper at a distance of 1 m
20	10^{-10}	$2 \cdot 10^{-4}$	ticking of pocket watch; a whisper
30	10^{-9}	$6.3 \cdot 10^{-4}$	the reading hall in a library
40	10^{-8}	$2 \cdot 10^{-3}$	subdued talk; low music
50	10^{-7}	$6.3 \cdot 10^{-3}$	weak sound of a loudspeaker
60	10^{-6}	$2 \cdot 10^{-2}$	loud talk; moderately busy street
70	10^{-5}	$6.3 \cdot 10^{-2}$	a truck; noise inside a tram; a piano 10 m away
80	10^{-4}	$2 \cdot 10^{-1}$	a metal-cutting machine; loudspeaker at maximum volume; a busy street
90	10^{-3}	$6.3 \cdot 10^{-1}$	old metro car; ambulance siren
100	10^{-2}	2	the flight compartment of a passenger plane
110	10^{-1}	6.3	fire engine siren; fast train; jackhammer
120	1	20	piston airplane engine; strong thunder
130	10	63	rocket engine; painful sensation

Table 1. Parameters of sound for different examples.

which a wave should travel to sufficiently distort its shape, is called the length of breaker formation. Like any nonlinear phenomenon, the distortion of a wave's contour depends on the wave's amplitude P_0 : The length of breaker formation is inversely proportional to the amplitude—that is, $l_b \sim 1/P_0$. The more intense the wave, the greater its amplitude, and the less distance is needed to distort and break its contour.

However, there is a rival process—the damping of a wave in a viscous medium. Due to this damping, the wave amplitude decreases, which results in some “braking” of the wave contour distortion. If the damping is rather strong and occurs over a distance l_d that is smaller than l_b , the nonlinearity can be suppressed and may not appear at all. Naturally, parameter l_d , similar to l_b , depends on the characteristics of the medium in which the sound propagates.

Now we can formulate a more exact definition of a powerful acoustic wave: It is a wave for which $l_b < l_d$. The ratio l_d/l_b is called the acoustic Reynolds number (Re). If $Re > 10$, the wave is intense, and if $Re \ll 1$, it is weak. Reynolds number is $Re = \alpha p_0/f$, where f is the sound frequency, α is a certain constant characterizing the nonlinear and viscous properties of a medium (the “response” of a medium to a powerful impulse and the degree of its distortion by the medium). Values of this coefficient are different in various media: for example, for water $\alpha \sim 300$ (Pa · s)⁻¹. When sound of frequency $f \sim 1$ MHz propagates in water, $Re > 10$ for waves with an acoustic pressure $P_0 > 3 \cdot 10^4$ Pa. Thus, an intense sound wave in water is a wave with intensity

$$I = \frac{P_0^2}{2\rho c} > \frac{(3 \cdot 10^4)^2}{(2 \cdot 10^3)(1.5 \cdot 10^3)} \text{ W/m}^2$$

$$= 300 \text{ W/m}^2,$$

which corresponds to an acoustic pressure of $\beta > 180$ dB.

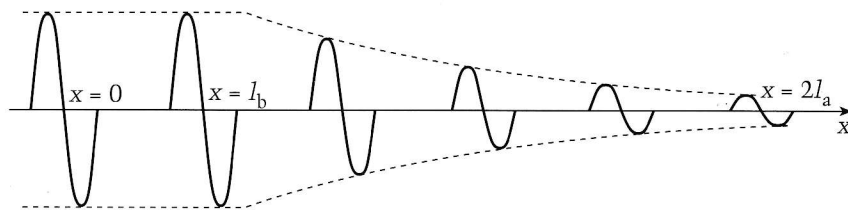

Figure 1

Let's return to the very tempting idea of transmitting high-density energy over large distances with the help of an acoustic beam. For a rather long time this idea was considered to be close to implementation. In recent years an inspiring example was laser radiation. Readers may know that powerful laser pulses can destroy structures and punch holes at large distances from the laser. At first glance, it seems that substituting sound for light in these operations is possible in principle, and only some technical hurdles must be overcome. However, there are fundamental obstacles that spoil the idea of creating a supersonic weapon.

The point is that for any given distance, there is a limiting value of sound wave intensity that can reach the target, and the smaller this limit is, the larger the distance to the targets.

The problem here is not the trivial attenuation of acoustic waves during propagation in an absorbing medium, which is described by the formula $P_x = P_0 \exp(-x/l_a)$. Usually the attenuation length of an acoustic wave decreases with frequency as $l_a \sim f^{-2}$. In other words, attenuation drastically increases with frequency. However, we can choose the frequency such that the usual (linear) attenuation at the necessary distances is negligible.²

Now imagine that at some point ($x = 0$) we generate a wave of amplitude and frequency at which the nonlinear effects are pronounced. Figure 1 shows the changes of its one-period oscillation during propa-

gation. We can see that in the first part of its path ($x \leq l_b$) the wave does not decay at all. However, at $x > l_b$, nonlinear attenuation occurs. The wave amplitude decreases with distance from the source as

$$P_0(x > l_b) = \frac{P_0}{1 + \frac{x}{l_b}}.$$

So, the larger the initial amplitude P_0 , the quicker it fades. At very large initial amplitudes, the 1 in the denominator can be omitted, so the amplitude drops as $1/x$, and the rate of decay does not depend on the initial pressure P_0 , because $l_b \sim 1/P_0$. This attenuation proceeds to distances where the nonlinear effects disappear, and thereafter the wave propagates linearly. Linear decay is far less pronounced and does not depend on the initial signal.

We can obtain a formula for the maximum amplitude of the sine wave at the input of a medium, taking into account both nonlinear (due to the formation of the steep wave front) and linear attenuation (which is described by the attenuation coefficient $1/l_a$):

$$\lim_{P_0 \rightarrow \infty} P_0(x > l_b) = P_{\max}(x) = \frac{4f}{\alpha} e^{-x/l_a}.$$

Again note that the signal amplitude $P_0(x)$ at the finish (at distance $x \gg l_b$) does not depend on the signal amplitude P_0 at the start. We cannot transmit pressure larger than $P_{\max}(x)$ for any given distance no matter how powerful the sound generator and how large the amplitude of the source signal!

Let's try to estimate the maximum intensity that can be transmitted through 100 m of water by an

²For a 1-MHz ultrasonic wave propagating in water, $l_a \cong 50$ m, while l_b for a high-frequency ultrasonic wave may be only 10 cm.

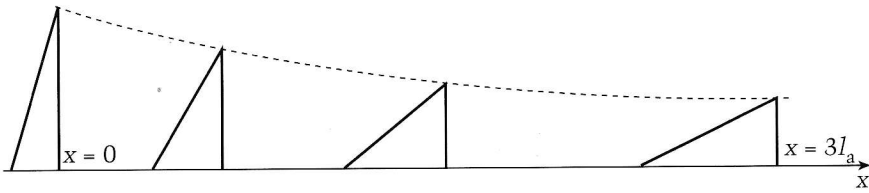

Figure 2

ultrasonic wave with frequency 1 MHz:

$$I_{\max} = \frac{P_{\max}^2(x=100\text{ m})}{2c\rho} = \frac{8f^2}{c\rho\alpha^2} e^{-2x/l_a}$$

Inserting the values $c \cong 1.5 \cdot 10^3$ m/s, $\rho \cong 10^3$ kg/m³, $\alpha \cong 300$ (Pa · s)⁻¹, and $l_a \cong 50$ m, we get $I_{\max} \cong 1$ W/m². Therefore, in the optimum conditions for the propagation of intense ultrasonic waves in water, we can transmit over 100 m only a small amount of energy, approximately equal to 1 J/m² of the receiving antenna. This is enough for a flashlight, but far from the power necessary to damage a ship or traumatize a sperm whale.

What a disappointing result! So how are the various technological applications of ultrasound possible? The answer is that these operations are performed at comparatively small distances from the acoustic generator, where nonlinear attenuation cannot yet damp a powerful wave and the saturation effect does not occur.

A reader may ask how we can explain the mighty effects of shock waves. We know that shock waves from explosions can destroy buildings at great distances from the explosion. Shock waves are a very nonlinear phenomenon, and nonlinear attenuation should progress more rapidly here than in the rather moderate waves usually considered in nonlinear acoustics.

The problem is that a single impulse (fig. 2) behaves quite differently than a periodic wave (fig. 1). Its peak value decreases with distance according to

$$P_0(x) = \frac{P_0}{\sqrt{1+x/l_b}}$$

Again, at large initial amplitudes P_0 , the 1 can be neglected in the denominator. In this case the amplitude of a single pulse at the observation point (say, an obstacle) does depend on the amplitude at the explosion point and is described by the formula

$$P_0(x) = P_0 \sqrt{\frac{l_b}{x}} \sim \sqrt{\frac{P_0}{x}}$$

The dependence on initial amplitude P_0 is very important here. We see that in a case where nonlinear effects are strongly manifested (that is, in the shock wave), the maximum value of $P_0(x)$ is not limited by some value, although it increases more slowly in comparison with the pressure of the sound generator (it's proportional to $\sqrt{P_0}$ and not to P_0 , as in the linear case). Thus, by increasing the power of an explosion and the initial amplitude of the sound wave, we can create any large pressure at any given distance and destroy a target.

Up to now we've considered the deformation of a powerful acoustic wave and the decrease in its amplitude as it travels through a medium. However, we haven't mentioned the most important thing—the change in its spectrum. This phenomenon is very important in applied acoustics.

Let's recall the notion of the spectrum of a signal. Usually the word *spectrum* is associated with magnificent photographs of the visible atomic emission spectra, which consist of bands of different colors. Every atom is characterized by its individual "spectral fingerprint." For example, the spectrum of sodium has a bright yellow line at the wavelength 0.59 μm . How-

ever hard we may try to transform a light wave of a given spectrum in a linear medium—sending it through any kind of light filters, scattering media, amplifiers, and so on—we'll never obtain new frequencies (that is, new spectral lines). However, nonlinear transformation by methods of nonlinear optics is another matter entirely. It's known that the infrared beam of a high-power laser can become red after passing through a specially chosen crystal. In so doing, it doubles its own frequency.³

A similar phenomenon of a multiple increase in frequency—or, in other words, the generation of higher harmonics—is also important in the physics of high-power acoustic waves. When we discussed the distortion of a harmonic signal (fig. 1), we actually brushed up against this effect. Indeed, the spectrum of the signal shown in figure 1 is composed of a set of equidistant frequencies: the fundamental frequency of the generated signal f (corresponding to the initial, nondistorted sinusoidal signal) and higher harmonics of frequency nf ($n = 2, 3, 4, \dots$), which arose as the acoustic wave propagated in a nonlinear medium. In other words, the distortion of the shape of the sinusoidal wave results in the appearance of higher harmonics in the spectrum. The amplitude of the second harmonic ($n = 2$) increases proportionally to the distance traveled by the wave. It can become comparatively large, so it can be measured quite accurately. On the other hand, when the distance between the sound radiator and the receiver is fixed, the amplitude of the second harmonic

³The article of B. Fabrikant "Through a Glass Brightly" (*Quantum*, September/October 1990, pp. 34–38) describes how visible light changes its color from green to red after traveling through several pieces of green glass. However, that phenomenon has nothing to do with nonlinear wave transformation. Can you guess why?

depends on the elastic properties of the medium, or as physicists and materials scientists say, on the *nonlinear modula* of the medium. If you're a devoted *Quantum* reader, you've come across Young's modulus any number of times. This parameter describes the elastic deformation of a solid body under the action of applied mechanical stress (recall Hooke's law). Young's modulus is a linear parameter, because according to Hooke's law, the deformation of a body is directly proportional to the stress (that is, it depends on the stress linearly). In case of large stresses, when the deformations cannot be considered elastic (the material becomes "plastic"—it "yields" or even crumbles), the dependence of deformation on stress is characterized not only by linear but also by nonlinear modula of the medium.

Thus, when we measure the amplitude of a second harmonic that has passed through a nonlinear medium, we thereby determine the nonlinear modula of this medium and, therefore, can describe its plasticity, strength, and other important characteristics.

Now we can understand one of the most important notions in nonlinear acoustics. When we study the parameters of solid bodies, we usually subject them to large stresses. Special devices exert loads of tens of thousands of atmospheres. Often, instead of using bulky and expensive equipment, we can use a far simpler method. A sound radiator is attached to the end face of a rod, and an intense wave is generated in the sample. On the other face of the rod, the nonlinear signal is recorded (for example, by measuring the amplitude of the second harmonic), which contains the information we seek about the characteristics of the material.

In contrast to linear waves, an intense wave "remembers" the properties of the medium through which it propagates. This is why nonlinear signals are used to analyze

soils and water, which may be impervious to other types of radiation but "transparent" to sound.

If an intense sound wave encounters another wave (signal), it "remembers" the meeting and its characteristics will change. In other words, an intense beam serves as a kind of probe (or antenna). Just imagine: If we just increase the power of the sound radiated into, say, water, we get a receiving hydroacoustic antenna spread over tens or hundreds of meters. The role of the antenna in such a setup is played by the water column that contains the acoustic beam—that is, by the space between the sound generator and the receiver. Of course, nothing of this kind is possible with weak waves. We know that two linear waves pass freely through one another, creating an interference pattern in the area where they cross. Leaving this area, each wave travels on as if it had never encountered the other.

An intense beam can be not only a receiving antenna but also a transmitting antenna. Devices that radiate sound by means of such antennas are called parametric radiators. What are these devices good for?

We know that the only kind of radiation that can travel great distances underwater is sound. Without acoustic communication, the oceans could not be tamed or their resources tapped. However, to obtain a narrow beam of directed ultrasonic radiation, we need very large antennas whose reflecting surfaces are tens of meters in diameter. The problem of constructing huge transmitting antennas can be avoided by using the nonlinear interaction of acoustic waves. To this end, two antennas of conventional size are used, which radiate the intense waves with frequencies f_1 and f_2 . These waves interact before fading at a distance of, say, 1 km from the antennas. As a result of this interaction, a new wave is generated that has a low (differential) frequency $f_1 - f_2$ and is attenuated far less than the source waves and thus

can travel much farther. Even more important is the fact that this far-reaching wave is generated not on the surface of the antenna (only ultrasonic waves with frequencies f_1 and f_2 are generated there), but deep in the water. Thus the kilometer-long column of water—the area where the waves interact—becomes a huge transmitting antenna. We don't need to build it—it's already there!

Parametric radiators are currently used in geophysics, medicine, and atmospheric research. However, these antennas are most widely used in marine research. They make it possible to study the relief of the ocean floor as well as the soil characteristics there. Parametric acoustics has also been applied in archaeology: scientists used it to search for valuables seized by Napoleon from the Kremlin in Moscow and discarded during the French army's retreat somewhere in the marshy, silted lakes near Smolensk; and in another instance, it uncovered objects from the first polar expeditions.

Still another application involves acoustic locators to find schools of fish at the surface or near the ocean floor, in the mouths of rivers, or in shoals—in other words, where standard acoustic devices can't do the work.

In this article we tried to describe just a few of the many interesting phenomena that occur in intense acoustic fields. Nonlinear acoustics is a relatively young science—only about forty years old. It abounds in problems to be studied by the younger generation of researchers who are interested in nonlinear physics and its applications. ●

Quantum articles on waves and sound:

Kaleidoscope: "Songs That Shatter and Winds That Howl," January/February, 1994, pp. 32–33.

Roman Vinokur, "The Importance of Studying the Physics of Sound Insulation," November/December 1995, pp. 18–23.

Do you really know

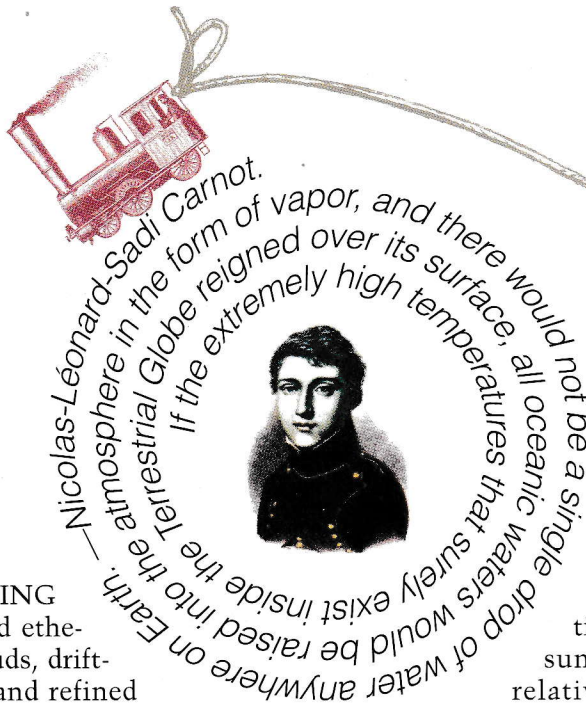

LIFE-GIVING rains and ethereal clouds, drifting fog and refined snow crystals—all are created by vapors. Water vapor in the air plays a big role in determining the weather. Accordingly, weather forecasts regularly include observations of relative humidity.

Vapor is also a concern of such various people as sportsmen and glaciologists, designers of steam boilers and engines, pilots and sailors, and housekeepers who hang laundry out to dry—all of them need to know about the properties and behavior of vapors. How much do you know about vapors?

Questions and problems

1. Why does a drop of water begin to "jump" after landing on a red-hot plate?
2. Under what conditions can an increase in the absolute humidity of air be accompanied by a decrease in its relative humidity?

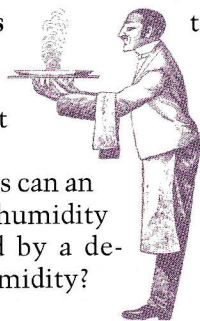

3. At what time of day in summer is the relative humidity higher at the same absolute humidity?
4. High air temperatures can be endured rather easily in deserts due to

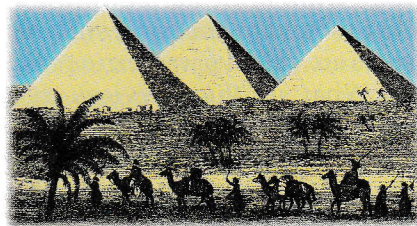

- the low humidity. Why are high temperatures unbearable at high humidity?
5. In spring, the water content in the soil around unmelted snowdrifts is higher than at some distance from them. Why?
6. It's drizzling on a cold autumn day, and the laundry is hung to dry. Will it dry near an open window?
7. Can an aspirator raise boiling water?

8. How can you convert unsaturated vapor into saturated vapor?
9. When can an increase in the density of a substance coincide with a rise in temperature?
10. A liquid is poured into connected vessels of different diameters. If the wider vessel is

plugged with a cork, will the levels in the vessels change as a result?

11. Saturated air-free water vapor is trapped under the piston in a cylinder. Will this vapor respond as an elastic body during compression?

12. A plastic bottle is filled to 9/10 of its volume with boiling water and plugged with a cork. Shaking the bottle may pop the cork.

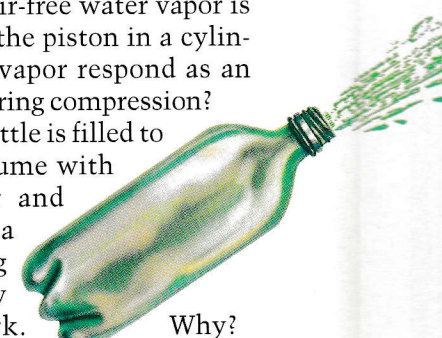

13. Why does fog hover after sunrise in autumn for a longer time over a river than over soil?

14. Precipitation occurs because larger drops grow from smaller ones. How do you explain this phenomenon?



Microexperiment

Water is boiling in two identical teakettles set on identical burners. The lid of one kettle jumps persistently while that of the other does not move. Why?

know vapors?



It is interesting that...

...if Earth's hydrologic cycle stopped, a layer of water 1.1 m deep would be evaporated in a year from the surface of the oceans.

...if a very clean vapor doesn't contact liquid, it can become supersaturated vapor when the temperature is

...in 1880, the Scottish marine engineer John Aptken discovered that during the formation of fog, clouds, and rain, water vapor condenses on microscopic particles such as sea-salt, specks of dust, and so on. Some modern methods of artificially stimulating rain are based on this discovery.

...the modern device for measuring water vapor, the infrared hydrometer, can operate in conditions when all other devices are virtually useless.

It compares two different wavelengths of infrared radiation that pass through a layer of air. One wavelength is absorbed by water vapor while the other travels through it safe and sound.

Quantum articles about vapors:

M. Anfimov and A. Chernoutsan, "While the water evaporates," July/August 1996, pp. 25-26.

I. Vorobyov, "Smoky mountain," November/December 1995, pp. 38-40.

I. Mazin, "An invitation to the bathhouse," September/October 1990, pp. 20-22.

A. Abrikosov, "The story of a dewdrop," September/October 1992, pp. 34-38.

A. Buzdin and V. Sorokin, "Double, double, toil and trouble," May/June 1992, pp. 52-53.

A. Stasenko, "Love and hate in the molecular world," November/December 1994, pp. 10-13.

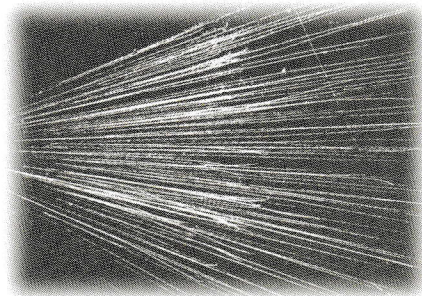

lowered. Such a vapor is used in the Wilson cloud chamber, designed for detecting elementary charged particles.

...the first hair hydrometer was constructed in 1783 by the Swiss geologist and naturalist Horace Bénédict de Saussure. In the same year he published a paper in which he proved that humid air is less dense than dry air at the same temperature and pressure.

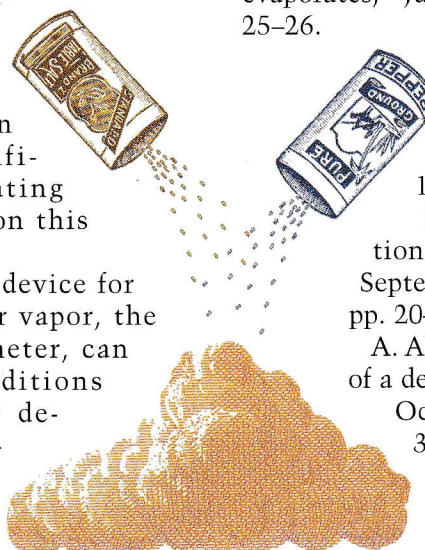
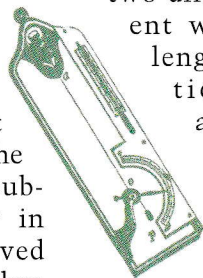

ANSWERS, HINTS & SOLUTIONS ON PAGE 55

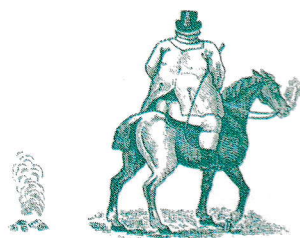

Up, up and away

by Arthur Eisenkraft and Larry D. Kirkpatrick

*Hands, do what you're bid:
Bring the balloon of the mind
That bellies and drags in the wind
Into its narrow shed.
—William Butler Yeats*

HE'S FULL OF HOT air! We all know what the expression means. Empty talk, unsubstantiated statements, pretentious verbiage, and boastful babble all come to mind when we hear the expression "full of hot air." Where did such a statement originate? O. Henry once said, "A straw vote only shows which way the hot air blows." What is there about hot air that would equate it to talking nonsense? Perhaps the hot-air diatribe is thought of as having no substance, ready to just float away.

As students of physics, we take a more substantial look at hot air. We know that hot air rises and is one means by which we can have a balloon soar above us. This month, we will ignore bees, birds, and helium-filled birthday balloons and let our minds soar with the hot air that levitates tourists on a Sunday afternoon or adventurers embarking on a 'round-the-globe expedition.

The hot-air balloon begins to rise because it is buoyant in the cooler surrounding air. It rises until the buoyant force is equal to the weight of the balloon and the air within it. To understand the rise and suspension of the balloon, we must then be reminded of the grand law of buoyancy, Archimedes' principle, and the determination of the density of the cooler air at different elevations.

Archimedes, prior to running through the streets shouting "Eureka!" realized that an object is buoyed up by a force equal to the weight of the displaced fluid. An elegant proof of this would assume that a block of water is floating amongst the rest of the water. The buoyant force, due to the pressure difference between the top and bottom of the slab of water, must be equal to the weight of the water for the static equilibrium that we observe. The pressure difference will be identical if another object replaces this slab of water. If, however, this object weighs more than the water it displaces, it will sink. If it weighs less than the water it displaces, it will rise.

Water is barely compressible, and the pressure differences will remain constant regardless of where the block is placed within the liquid. The atmosphere is compressible, and the pressure and density of the air varies with elevation. Assuming that the pressure and the density are proportional to one another (as they would be for a constant air tem-

perature), we can derive the equation relating the pressure to the elevation.

A fluid element is assumed to be at equilibrium within a larger fluid. For equilibrium, the pressure pushing up from the bottom must equal the pressure pushing down from the top surface plus the weight.

$$PA = (P + dP)A + dW$$

$$PA = (P + dP)A + \rho g A dy$$

$$\frac{dP}{dy} = -\rho g.$$

The pressure decreases with rising elevation.

Since we are assuming that the density is proportional to the pressure,

$$\frac{\rho}{\rho_0} = \frac{P}{P_0}$$

$$\frac{dP}{dy} = -g\rho_0 \frac{P}{P_0}$$

$$\frac{dP}{P} = -\frac{g\rho_0}{P_0} dy$$

$$\ln \frac{P}{P_0} = -\frac{g\rho_0}{P_0} y$$

$$P = P_0 e^{-\frac{g\rho_0}{P_0} y}$$

Art by Tomas Bunk

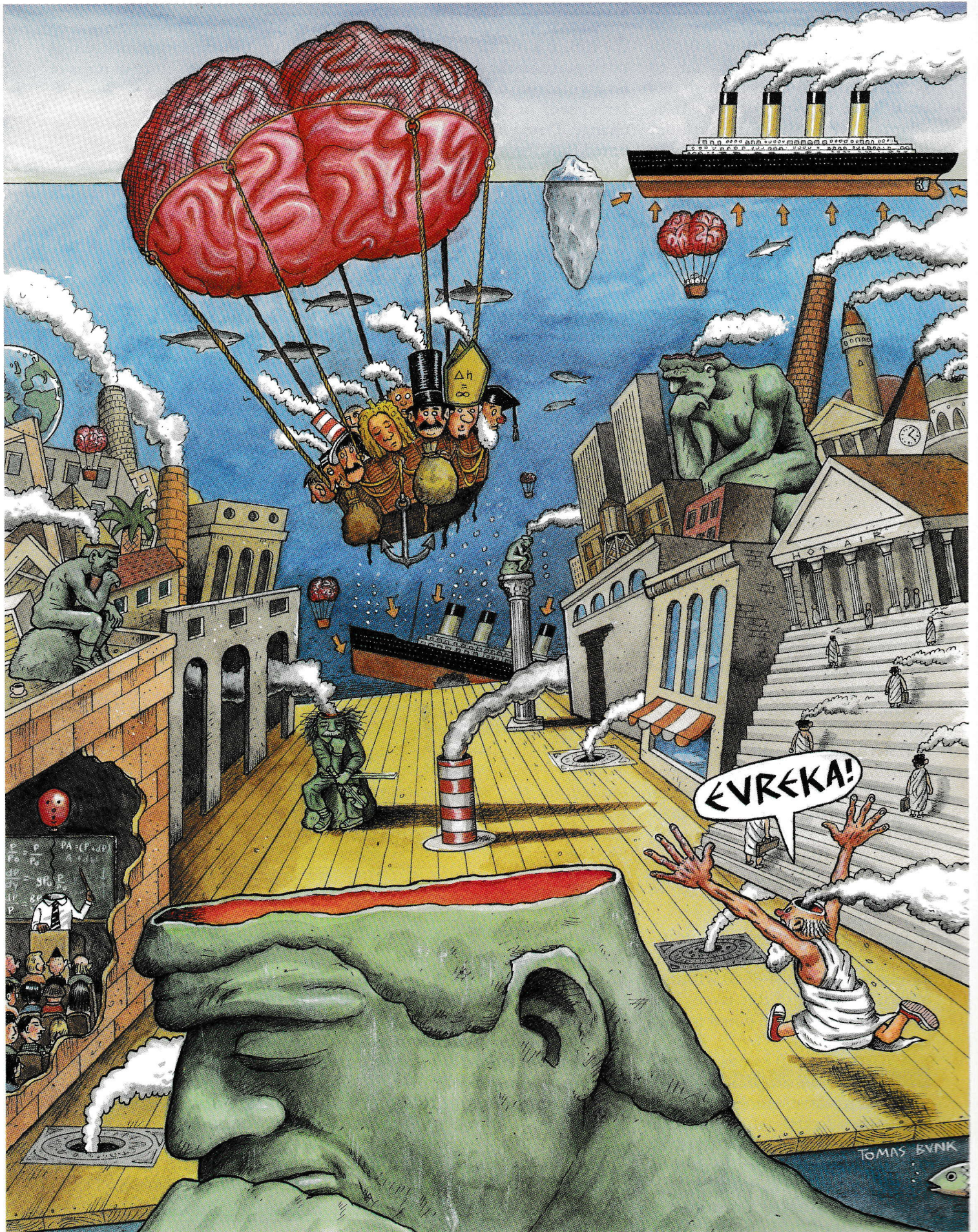

With Archimedes' principle and the derived dependence of pressure on elevation, we are now ready to embark on our journey through this month's contest problem. It is adapted from the International Physics Olympiad problem given in Germany in 1982.

A hot-air balloon, when inflated, has a constant volume $V_1 = 1.10 \text{ m}^3$. The mass of the balloon material is $m_b = 0.187 \text{ kg}$, and its volume is negligible. The initial temperature of the air is $T_1 = 20.0^\circ\text{C}$, and the atmospheric pressure outside the balloon is $P_0 = 1.013 \cdot 10^5 \text{ N/m}^2$. Under these conditions, the density of the air is $\rho_1 = 1.20 \text{ kg/m}^3$.

A. To what temperature must the air in the balloon be heated for the balloon to begin to float?

B. The balloon is tethered to the ground, and the air in the balloon is heated to a steady state temperature of 110°C . What is the net force on the balloon when it is released?

C. The balloon is tethered to the ground, and the air in the balloon is heated to a steady state temperature of 110°C and released. The balloon rises isothermally in the atmosphere, which is assumed to have a constant temperature of 20°C . Determine the height gained by the balloon under the conditions described.

D. The balloon hovers at the height calculated in part C and then is pulled from its equilibrium position by $\Delta h = 10 \text{ m}$ and released. Describe the subsequent motion of the balloon.

Please send your solutions to *Quantum*, 1840 Wilson Boulevard, Arlington, VA 22201-3000 within a month of receipt of this issue. The best solutions will be noted in this space.

Around and around she goes

Three readers sent in different approaches to the solution of the first problem in the March/April issue of *Quantum*. Art Hovey, a teacher at Amity Regional High School in Woodbridge, Connecticut,

stated that when the chip breaks off the rim of a rotating disk, it exerts no impulse on the disk, so the angular momentum (and, thus, the angular speed) of the disk does not change. David Heller, his student, noted that the angular momentum of the particle is initially $mR^2\omega_0$ and finally mvR . But $v = \omega_0 R$, and the angular momentum of the particle doesn't change. By the conservation of angular momentum, the angular momentum of the disk doesn't change. Rob Morasco from Hatfield, Pennsylvania, used a more mathematical approach. Conservation of angular momentum requires

$$I_0\omega_0 = (I_0 - mR^2)\omega_f + mR^2\omega_0.$$

Rearranging terms,

$$(I_0 - mR^2)\omega_0 = (I_0 - mR^2)\omega_f.$$

Therefore, $\omega_f = \omega_0$.

The problem in which the ball of mass m and speed v hits a stick of mass M and length a proved to be a bit more difficult. As with all collision problems, we must conserve momentum. Conservation of linear momentum gives us

$$mv = MV,$$

where V is the speed of the stick's center of mass and the final speed of the ball is zero. Therefore,

$$V = \frac{m}{M}v.$$

Because the ball strikes the stick

near one end and perpendicular to the stick, the angular momentum of the ball about the center of mass of the stick is

$$L_i = mv\frac{a}{2}.$$

The angular momentum of the stick about its center of mass is

$$L_f = I\omega = \frac{1}{12}Ma^2\omega,$$

where ω is the stick's angular speed about its center of mass.

Conservation of angular momentum then yields

$$\omega = \frac{6mv}{Ma}.$$

Art Hovey was able to find the condition on the masses for such a collision to be possible. We know that the kinetic energy after the collision cannot exceed the kinetic energy available before the collision. Therefore,

$$\begin{aligned} \frac{1}{2}mv^2 &\geq \frac{1}{2}MV^2 + \frac{1}{2}I\omega^2 \\ &= \frac{1}{2}M\left(\frac{m}{M}v\right)^2 + \frac{1}{2}\left(\frac{1}{12}Ma^2\right)\left(\frac{6mv}{Ma}\right)^2 \\ &= \frac{1}{2}mv^2\left(\frac{4m}{M}\right), \end{aligned}$$

and

$$M \geq 4m. \quad \blacksquare$$

QUANTUM

makes a perfect gift!

Use the response card in this issue to order *Quantum* for your child, grandchild, nephew, niece, mother, father, friend . . . Or phone **1 800 SPRINGER**. Six colorful, challenging, entertaining issues—\$18.00 for full-time students, \$25.00 for adults.

Factor *x* into the *Quantum* equation,
where *x* is any potential *Quantum* reader you know!

HOW DO YOU FIGURE?

Challenges

Math

M241

Squared and cubed. Find all real solutions to the equation

$$(x^2 + 100)^2 = (x^3 - 100)^3.$$

M242

Proof perpendicular. Let M be the point of intersection of the diagonals of the inscribed quadrilateral $ABCD$, where $\angle AMB$ is acute. An isosceles triangle BCK is constructed on the base BC such that $\angle KBC + \angle AMB = 90^\circ$. Prove that KM is perpendicular to AD .

M243

Scorched earth. A wildfire in Florida spreads in all directions at 1 km/h. A bulldozer arrives at the fire's edge when the fire has burned a circle of radius 1 km. The bulldozer moves at 14 km/h as it makes a trench that cuts off the fire. Find a path for the bulldozer such that the total area burned will be no larger than (a) $4\pi \text{ km}^2$; (b) $3\pi \text{ km}^2$. (You may assume that the grader's path consists of line segments and arcs of circles.)

M244

Blocky world. The planet Brick is a rectangular parallelepiped with edges of 1, 2, and 4 km. The Prince of Brick built a brick house at the center of one of the largest faces. What is the distance from the house to the farthest point on the planet? (The distance between two points is defined as the length of the shortest connecting path along the planet's surface.)

M245

Range finder. The real numbers a , b , and c satisfy the conditions

$$\begin{aligned} 0 < a \leq b \leq c, \\ a + b + c &= 7, \\ abc &= 9. \end{aligned}$$

Find the range of possible values for each of the variables a , b , and c . (Warning: Our solution involves calculus.)

Physics

P241

Bubble in glycerin. A small air bubble is in the middle of a long, cylindrical tube filled with glycerin. When the tube is vertical, the bubble moves at a constant $v_0 = 1 \text{ cm/s}$.

If the tube begins horizontal and then is accelerated in the direction of its length to the speed $v = 20 \text{ m/s}$, at what position will the bubble stop? Where will the bubble stop if the tube's speed is gradually increased to 30 m/s ? Where will the bubble be after the tube decelerates to zero speed? (A. Andrianov)

P242

Helium under pressure. The dependence of the scaled temperature T/T_0 of helium on the pressure p/p_0 has the shape of a circle with its center at the point $(1, 1)$. The minimum temperature of helium in this process is τ_m . Find the ratio of minimum to maximum helium atomic concentration in this process. (V. Pogozhev)

P243

Compound fuse. A lead wire of diameter $d_1 = 0.3 \text{ mm}$ is melted by an

electric current $I_1 = 1.8 \text{ A}$, and another lead wire ($d_2 = 0.6 \text{ mm}$) melts at the current $I_2 = 5 \text{ A}$. At what current will a fuse blow if it is made of two such wires of the same length connected in parallel? What current will blow the fuse if in addition to a single thick wire it is made of 20 thin wires that have the same length and are also connected in parallel? (A. Khodulev)

P244

Magnetic lift. A rigid thin conducting ring lies on a nonconducting horizontal surface in a homogeneous magnetic field B , which has horizontal magnetic lines of force. The mass of the ring is m , and its radius is R . What current in the ring will cause it to rise off the surface? (S. Krotov)

P245

X-ray examination. An X-ray unit consists of a point source S and a receiver R firmly fixed on a frame. A thick-walled, cylindrical vessel is placed between S and R (figure 1).

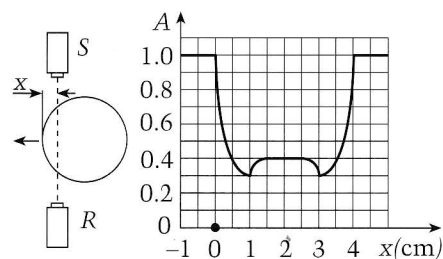

Figure 1

The plot shows the intensity of the X-ray radiation, which varies with the x -coordinate. Is there any substance absorbing the radiation inside the cylinder? (A. Andrianov)

ANSWERS, HINTS & SOLUTIONS
ON PAGE 50

High-speed conservation

by A. Korzhuyev

TO SOLVE PROBLEMS dealing with bodies moving at speeds approaching the speed of light, we need the laws of conservation of momentum and energy, which are well known in classical mechanics, but written in a special form.

Thus, the relativistic momentum and total energy of a body with rest mass m_0 moving at speed v is given by the formulas:

$$\mathbf{p} = \frac{m_0 \mathbf{v}}{\sqrt{1 - v^2/c^2}},$$

and

$$E = \frac{m_0 c^2}{\sqrt{1 - v^2/c^2}},$$

where c is the speed of light. These formulas are true only for particles whose rest mass is not zero. The photon—which moves at the speed of light and has zero rest mass—has an energy

$$E = h\nu$$

and momentum

$$p = h\nu/c,$$

where $h = 6.62 \cdot 10^{-34} \text{ J} \cdot \text{s}$ is Planck's

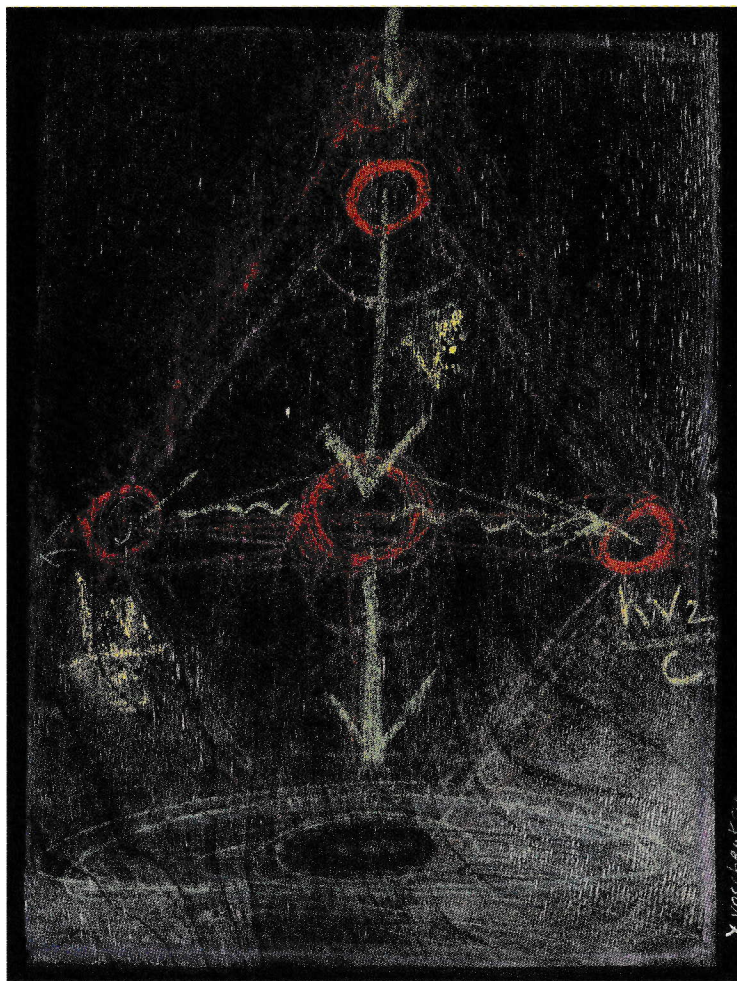

constant and ν is the frequency of the photon. Now let's try our knowledge in practice.

Problem 1. Two gamma rays are produced by the annihilation of an electron and a positron, both of which were moving slowly. At what angle do they fly away from each other? What are their frequencies?

Solution. This annihilation pro-

cess can be considered with the help of conservation of energy and momentum:

$${}^1_0\bar{e} + {}^{-1}_0e \rightarrow 2\gamma.$$

Since the initial velocities of the particles are small, conservation of momentum yields

$$0 = \frac{h\nu_1}{c} - \frac{h\nu_2}{c},$$

so

$$\nu_1 = \nu_2.$$

The photons must leave in opposite directions (figure 1), because only in this case can the total momentum of the particles be zero after interacting.

Conservation of energy produces

$$2m_0c^2 = h\nu_1 + h\nu_2,$$

and taking into account that $\nu_1 = \nu_2 = \nu$,

$$\nu = \frac{m_0c^2}{h}.$$

Problem 2. A neutral particle traveling at $v = 0.8c$ decayed into two photons that went in opposite directions after the event (fig. 2). What is the ratio of the frequencies of these quanta?

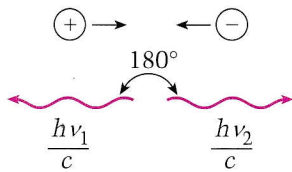

Figure 1

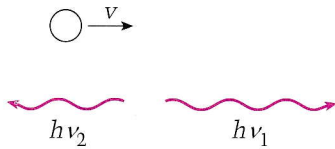

Figure 2

Solution. Again we use conservation of momentum and energy. The initial momentum of the particle is equal to the sum of the projections of the photons' momenta on the initial direction of the particle's motion

$$\frac{m_0 v}{\sqrt{1 - v^2/c^2}} = \frac{h\nu_1}{c} - \frac{h\nu_2}{c}.$$

The particle's total energy equals the total energy of the quanta:

$$\frac{m_0 c^2}{\sqrt{1 - v^2/c^2}} = h\nu_1 + h\nu_2.$$

Upon inserting the value $v = 0.8c$ into these formulas and multiplying the left- and right-hand terms of the first formula by c , we get

$$\frac{4}{3} m_0 c^2 = h\nu_1 - h\nu_2,$$

$$\frac{5}{3} m_0 c^2 = h\nu_1 + h\nu_2.$$

Adding and subtracting these equations yields the frequencies of radiation:

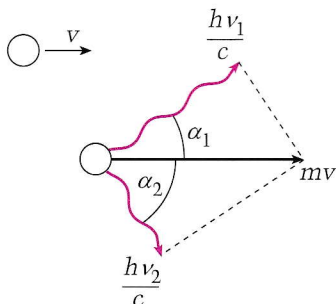

Figure 3

$$v_1 = \frac{3m_0 c^2}{2h},$$

$$v_2 = \frac{m_0 c^2}{6h},$$

and the desired ratio

$$\frac{v_1}{v_2} = 9.$$

Problem 3. The disintegration of a moving neutral particle produced two photons moving at angles $\alpha_1 = 30^\circ$ and $\alpha_2 = 60^\circ$ to the initial trajectory of the particle. What was the speed of the particle?

Solution. In this case conservation of momentum should be "projected" onto the horizontal and vertical axes (fig. 3):

$$\frac{m_0 v}{\sqrt{1 - v^2/c^2}} = \frac{h\nu_1}{c} \cos \alpha_1 + \frac{h\nu_2}{c} \cos \alpha_2, \quad (1)$$

$$0 = \frac{h\nu_1}{c} \sin \alpha_1 - \frac{h\nu_2}{c} \sin \alpha_2. \quad (2)$$

Conservation of energy yields

$$\frac{m_0 c^2}{\sqrt{1 - v^2/c^2}} = h\nu_1 + h\nu_2. \quad (3)$$

Inserting the relationships $\sin \alpha_1 = 1/2$ and $\sin \alpha_2 = \sqrt{3}/2$ into (2), we get

$$v_1 = v_2 \sqrt{3}.$$

Plugging this into equations (1) and (3) results in

$$\frac{m_0 v c}{\sqrt{1 - v^2/c^2}} = 2h\nu_2,$$

$$\frac{m_0 c^2}{\sqrt{1 - v^2/c^2}} = h\nu_2 (\sqrt{3} + 1).$$

Now we divide these equations by one another and get

$$\frac{c}{v} = \frac{\sqrt{3} + 1}{2}.$$

Finally,

$$v = \frac{2c}{\sqrt{3} + 1} \cong 0.73c.$$

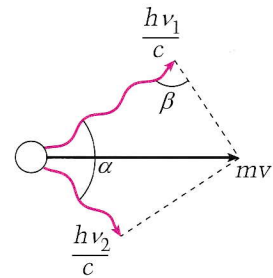

Figure 4

Problem 4. The disintegration of a particle moving at $v = 0.8c$ produces two photons. Find the minimum angle at which these photons diverge.

Solution. Conservation of energy and momentum results in (fig. 4)

$$\frac{m_0 c^2}{\sqrt{1 - v^2/c^2}} = h\nu_1 + h\nu_2,$$

$$\left(\frac{m_0 v}{\sqrt{1 - v^2/c^2}} \right)^2 = \left(\frac{h\nu_1}{c} \right)^2 + \left(\frac{h\nu_2}{c} \right)^2 - \frac{2h^2 \nu_1 \nu_2 \cos \beta}{c^2},$$

where $\beta = 180^\circ - \alpha$.

Upon inserting $v = 0.8c$ and multiplying the second formula by c , we get

$$\frac{5}{3} m_0 c^2 = h\nu_1 + h\nu_2$$

$$\frac{16}{9} m_0^2 c^4 = (h\nu_1)^2 + (h\nu_2)^2 + 2h^2 \nu_1 \nu_2 \cos \alpha.$$

Now we add and subtract $2h^2 \nu_1 \nu_2$ in the last equation:

$$\frac{16}{9} m_0^2 c^4 = (h\nu_1 + h\nu_2)^2 - 2h^2 \nu_1 \nu_2 (1 - \cos \alpha).$$

Since the total energy of the photons is constant and equal to $(5/3)m_0 c^2$, we have

$$2h^2 \nu_1 \nu_2 (1 - \cos \alpha) = m_0^2 c^4$$

which can be rearranged to

$$1 - \cos \alpha = \frac{m_0^2 c^4}{2h^2 \nu_1 \nu_2}.$$

To make the angle α (or the difference $1 - \cos \alpha$) as small as possible,

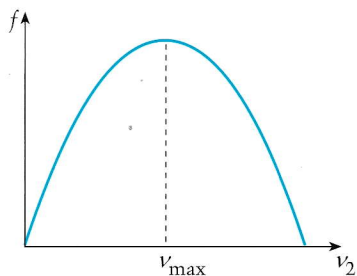

Figure 5

the product $v_1 v_2$ should be as large as possible. We know from math that the product of two numbers whose sum is constant will be largest when both factors are equal. This is exactly our case, because $h v_1 + h v_2 = (5/3)m_0 c^2$, so $v_1 = v_2$.

Now we'll prove this rigorously. Let's write the product $v_1 v_2$ (it's more convenient to use $h v_1 h v_2$ for this purpose) as $[(5/3)m_0 c^2 - h v_2] h v_2$ and examine the maximum of the function

$$\begin{aligned} f(v_2) &= \left(\frac{5}{3} m_0 c^2 - h v_2 \right) h v_2 \\ &= \frac{5}{3} m_0 c^2 h v_2 - h^2 v_2^2. \end{aligned}$$

The graph of this function is a parabola (fig. 5) that peaks at

$$v_2 = \frac{5}{6} \frac{m_0 c^2}{h}.$$

Thus,

$$h v_1 = \frac{5}{3} m_0 c^2 - \frac{5}{6} m_0 c^2 = \frac{5}{6} m_0 c^2,$$

and the desired product is

$$v_1 v_2 = \frac{25}{36} \frac{m_0^2 c^4}{h^2}.$$

Upon inserting this value into the expression for $(1 - \cos \alpha)$ we get

$$1 - \cos \alpha_{\min} = 18/25 = 0.72,$$

from which we obtain

$$\alpha_{\min} = \arccos 0.28 \cong 47^\circ.$$

Problem 5. Can a free electron absorb a photon?

Solution. Again we use conservation of energy and momentum. Let the electron be at rest before absorbing a photon and then let it acquire speed v . Conservation of energy

yields

$$m_0 c^2 + h v = \frac{m_0 c^2}{\sqrt{1 - v^2/c^2}}$$

and conservation of momentum results in

$$\frac{h v}{c} = \frac{m_0 v}{\sqrt{1 - v^2/c^2}}.$$

Inserting the expression of $h v$ obtained from the second equation into the first one, we get

$$m_0 c^2 + \frac{m_0 v c}{\sqrt{1 - v^2/c^2}} = \frac{m_0 c^2}{\sqrt{1 - v^2/c^2}}.$$

After rearrangements we have

$$(c - v)^2 = c^2 - v^2.$$

This equation has the formal roots $v = c$ and $v = 0$. In other words, the speed of the electron should be equal either to c , which is impossible, or to zero, which doesn't work, because in this case the photon's frequency must be zero.

Well, the theory of relativity isn't so frightening after all! \blacksquare

Erratum

The gunfire racing problem (P232, May/June 1998) stated: A projectile was fired horizontally from a mountain at an altitude $h = 1$ km with a velocity $v = 500$ m/s. After the time $t_0 = 1$ s, another shell was fired in pursuit of the first. What must the minimum initial velocity of the second shell be and at what angle should it be fired to hit the first shell?

Assuming that the author meant for the two projectiles to collide in flight, the answer given is wrong. As the author's analysis correctly indicates, the minimum velocity occurs at the instant just before the two projectiles hit the ground. For the two projectiles to collide earlier requires a larger velocity.

The first projectile will hit the ground in a time $T = \sqrt{2h/g} = 100/7$ s at a horizontal distance $x = (500 \text{ m/s})T = 50,000/7$ m from

its starting point. The second projectile must reach this same point in a time $t = (T - 1) \text{ s} = 93/7$ s. Consequently, after a time t , the horizontal distance of the second projectile from its starting point must be given by $v_0 \cos \alpha_0 t = 50,000/7$ m.

Similarly, after a time t , the vertical distance of the second projectile from its starting point must be given by $-1,000 \text{ m} = -gt^2/2 + v_0 \sin \alpha_0 t$. The horizontal displacement equation gives $v_0 \cos \alpha_0 = 50,000/93$ m/s. The vertical displacement equation gives $v_0 \sin \alpha_0 = -945.7/93$ m/s. Dividing gives $\tan \alpha_0 = -945.7/50,000$, or $\alpha_0 = \tan^{-1}(-0.018914)$. The minimum velocity is then given by

$$\frac{50,000}{93 \cos \alpha_0} \text{ m/s} \cong 537.73 \text{ m/s}.$$

The author's answer of 535.1 m/s is not correct.

The author's solution has two er-

rors. First, the equation for v_y is written with a cosine instead of a sine. This appears to be a typographical error, because the answer is consistent with the use of the sine function. The second error is more fundamental. In calculating the speed v' , the author uses the entire time of flight for the first bullet rather than this time minus t_0 . Consequently, the equation for v' in the solution should read

$$v' = \frac{s_0}{\sqrt{\frac{2h}{g} - t_0}}.$$

Using $t_0 = 1$ s and substituting the recomputed value for v' in the author's solution yields the correct answer of approximately 537.73 m/s, which is consistent with the alternative solution discussed above.

—Submitted by John W. Hanneken, The University of Memphis.

Scientific Explorations in Time, Space, and Play from Springer

D. FISCHER, *Sterne and Weltraum, Königswinter, and H. DUERBECK, University of Munster, both, Germany*

Hubble Revisited

New Images from the Discovery Machine

Arguably the single most successful scientific instrument ever built, the Hubble Space Telescope continues to dazzle us. In recent months it has discovered the most distant known galaxy and the most massive known star, and has been at the front lines of all the most pressing questions in astrophysics. What is the age of the Universe? How are stars born? Are extrasolar planets similar to those in our galaxy?

In *Hubble Revisited: The Discovery Machine*, the authors of the highly acclaimed *Hubble: A New Window to the Universe* present a new atlas of the latest full-color images, complete with easy-to-read explanatory text. This book provides readers with an exciting, detailed, and gorgeously illustrated account of Hubble's breathtaking discoveries.

Acclaim for *Hubble: A New Window to the Universe* (ISBN 0-387-94672-1, \$40.00):
"...it is the color pictures which make this book wonderful to behold. Buy it and feast your eyes."
— NEW SCIENTIST

"A wonderful volume...a clear and insightful explanation is included for each and every image."
— THE PLANETARIAN

NOVEMBER 1998/APPROX. 208 PP., 100 COLOR ILLUS./HARDCOVER/\$40.00/ISBN 0-387-98551-4

P.J. NAHIN, *University of New Hampshire, Durham*

Time Machines

Time Travel in Physics, Metaphysics, and Science Fiction

Second Edition

from the foreword of the second edition—

"The most thorough compendium ever written on time travel in science fiction...also the most thorough review of serious scientific literature on the subject... I am struck by the richness and complexity of the tapestry of ideas that Nahin presents."
— KIP THORNE, Cal Tech, Pasadena, author of *Black Holes and Time Warps*

from reviews of the first edition—

"Here's a gem of a book...all peppered with delightful notes from science fiction films, novels, and comics. I can't turn a page without finding a jewel."
— CLIFFORD STOLL, University of California, Berkeley, author of *The Cuckoo's Egg*

Explores the idea of time travel from the first account in English literature to the latest theories of physicists such as Kip Thorne and Igor Novikov. This very readable work covers a variety of topics including the history of time travel in fiction; the fundamental scientific concepts of time, space-time, and the fourth dimension; the speculations of Einstein, Richard Feynman, Kurt Goedel, and others; time travel paradoxes, and much more.

AIP PRESS 1998/APPROX. 640 PP., 75 ILLUS./SOFTCOVER /\$34.00/ISBN 0-387-98571-9

C. J. HOGAN, *Seattle, WA*

The Little Book of The Big Bang

A Cosmic Primer

"Hogan compresses the fifteen-billion-year history of the Universe into a pleasurable evening. In a very direct way, he answers the questions everyone asks."

— MARGARET GELLER, Harvard-Smithsonian Center for Astrophysics

"This delightful little primer brings you right up to the cutting edge of modern cosmology."

— GEORGE SMOOT, Principal Investigator, COBE and author of *Wrinkles in Time*

"An excellent bridge by which the layperson can enter the domain of the Cosmos with understanding."
— ROBERT WILLIAMS, Director, Space Telescope Science Institute

AIP PRESS 1998/181 PP., 27 ILLUS./HARDCOVER/\$20.00/ISBN 0-387-98385-6

D.A. LIND, *University of Colorado, Boulder, and S.P. SANDERS, University of New Mexico, Albuquerque*

The Physics of Skiing

Skiing at the Triple Point

"Delivered with insight and clarity, this book deserves a spot on the shelf of any ski devotee and winter mountaineer. [It] presents a collection of ideas that has something to offer each time it's opened."

— LINDA CROCKETT, Education Director, Professional Ski Instructors of America

"This skier and physicist found it a pleasure to read about the history of skiing and to have a well-written book on the physics of snow, equipment, and skiing techniques (also snowboarding.)"

— ERNEST M. HENLEY, Physics Department, U. Washington

AIP PRESS 1997/250 PP., 98 ILLUS./SOFTCOVER/\$26.00/ISBN 1-56396-319-1

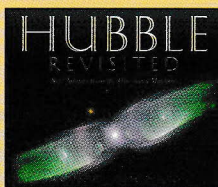

A. SHIMONY

Illustrations by JONATHAN SHIMONY

Tibaldo and the Hole in the Calendar

"This is the story of Tibaldo's great struggle to save his 12th birthday feast. It is in the grand tradition of Alice in Wonderland and Winnie the Pooh — a children's book that will delight adults."

— PHYSICS TODAY

When Pope Gregory XII decrees a long-needed calendar reform, part of the correction involves dropping ten days from the year. Social upheaval ensues. Determined to recover his birthday, the quick-witted hero, Tibaldo, manages an audience with Pope Gregory and speaks his mind. This story cleverly weaves an enjoyable account of the cultural and scientific milieu of 16th century Italy. Beautifully illustrated with drawings that reflect the style of the era, *Tibaldo and the Hole in the Calendar* offers a fascinating look at the Renaissance period and a delightful tale that will entertain readers of all ages.



AIP PRESS 1997/165 PP, 85 ILLUS./HARDCOVER/\$21.00/ISBN 0-387-94935-6

F.G. MAJOR, *Catholic University, Emeritus, Washington, DC*

The Quantum Beat

The Physical Principles of Atomic Clocks

This intriguing book examines the physical principles underlying the workings of clocks — from the earliest mechanical clocks to the present-day sophisticated clocks based on the properties of individual atoms. The presentation covers a broad range of salient topics relevant to the measurement of frequency and time intervals. The main focus is on electronic time-keeping: clocks based on quartz crystal oscillators and, at greater length, atomic clocks based on quantum resonance in rubidium, cesium, and hydrogen atoms, and, more recently, mercury ions. Intended for non-specialists with some knowledge of physics or engineering, the book explains the myriad workings of clocks of all kinds and our fundamental reliance on them.

1998/489 PP., 230 ILLUS./HARDCOVER/\$49.95/ISBN 0-387-98301-5

L. MÉRO

Moral Calculations

Game Theory, Logic, and Human Frailty

Is there such a thing as rational behavior, and if so, how do we use it to our advantage? Hungarian mathematician László Méro introduces us to the basics of John von Neumann's game theory and shows how it illuminates such aspects of human psychology as altruism, competition, and politics. Méro covers such concepts as zero-sum games; Prisoner's Dilemma, the game of Chicken, where logic proves that the rational strategy is to be irrational; how to be kind to your love through game theory; and when the Golden Rule works and when it leads to disaster. He also shows how game theory is applicable to fields ranging from physics to evolutionary biology, and explores the role of rational thinking in the context of real-life situations ranging from doorway etiquette to the nuclear arms race.



AIP PRESS 1998/287 PP./HARDCOVER/\$28.00/ISBN 0-387-98419-4

T.P. JORGENSEN, *University of Nebraska, Lincoln*

The Physics of Golf

"For anyone who has swung a golf club, the book is fun to read."

— ROBERT K. ADAIR, author of *The Physics of Baseball*

"Jorgensen tells golfers what they ought to be doing and why, the correct technique according to the principles of physics."

— GOLF WEEKLY

"The heart of golfer Ted Jorgensen's delightful book lies in his analysis of the swing of the golf club and how, armed with insights from that analysis, you, he and I might all swing the club better and play better golf... The exposition is designed to be accessible to the casual reader while satisfying the critical student. But first word or last, for anyone who has swung a golf club, the book is fun to read."

— PHYSICS TODAY



AIP PRESS 1997/155 PP., 36 ILLUS./SOFTCOVER/\$27.00/ISBN 0-88318-955-0

Four Easy Ways to Order:

- Call Toll Free: 800-SPRINGER 8:30 am to 5:30 pm EST or FAX: 201-348-4505; Please mention Code H307 when ordering by phone;
- Write to Springer-Verlag New York, Inc., Dept. H307, PO Box 2485, Secaucus, NJ 07096-2485;
- E-mail orders@springer-ny.com (outside North America, orders@springer.de);
- Visit your local scientific bookstore or urge your librarian to order.

Payment may be made by check, purchase order, or major credit card. Prices payable in U.S. dollars or the equivalent and subject to change without notice. Please include \$4.00 for shipping one book (\$1.00 for each additional) & appropriate sales tax if you reside in CA, IL, MA, MO, NJ, NY, PA, TX, VA, or VT. Canadian residents, please add 7% GST.

Remember...your 30-day return privilege is always guaranteed!

9/98

Promotion #H307



Springer

Auxiliary polynomials

by L. D. Kurlyandchik and S. V. Fomin

WE CAN REDUCE MANY problems to calculating the roots of an algebraic equation. But sometimes it turns out that to solve a problem we must construct a polynomial whose roots are the numbers that we are given. In what follows we will see how such auxiliary polynomials can help us solve various difficult problems. Many of these situations are related to those explored in *Gradus ad Parnassum* in the July/August 1998 *Quantum*. Later we will see that there is a very good

reason for this relationship.

Let u and v be two real numbers. What quadratic equation are they the roots of? The simplest way to answer this question is to consider the polynomial

$$P(t) = (t - u)(t - v) = t^2 + pt + q.$$

Its coefficients are given by the following formulas:

$$\begin{aligned} p &= -(u + v), \\ q &= uv. \end{aligned} \quad (1)$$

That is, the coefficients are equal to the sum of u and v , taken with the

opposite sign, and to the product of these numbers. (In some parts of the world, the formulas (1) are referred to as Vieta's formulas, after the sixteenth-century French mathematician François Viète. For convenience' sake, we'll follow suit.) In school you must have studied two theorems connected with these formulas:

- If u and v are the roots of a quadratic equation $t^2 + pt + q = 0$, then formulas (1) hold (Vieta's theorem);
- The numbers u and v are the roots of the quadratic equation



Art by Sergey Ivanov

$t^2 - (u + v)t + uv = 0$ (the converse of Vieta's theorem).

Now we'll give a few examples of problems where the converse theorem proves handy. Let's start with a simple problem.

Problem 1. Write down a quadratic equation with integer coefficients, one of whose roots is $2 + \sqrt{3}$.

Solution. The solution of this problem, as well as that of many other problems, is based on the observation that the quadratic equation whose leading coefficient is 1 and whose roots are the "conjugate" numbers $a + b\sqrt{d}$ and $a - b\sqrt{d}$, where a and b are integers, has integer coefficients. (For more on conjugate numbers, see "Unidentical twins" by V. N. Vaguten in the November/December 1997 *Quantum*.) This fact is, of course, a direct implication of formulas (1).

Thus, the roots of the equation we are looking for are $t_1 = 2 + \sqrt{3}$ and $t_2 = 2 - \sqrt{3}$, and therefore its coefficients are equal to

$$p = -(t_1 + t_2) = -4$$

and

$$q = t_1 t_2 = 1.$$

Answer. $t^2 - 4t + 1 = 0$.

Problem 2. Does the number $t_1 = \sqrt{37} - \sqrt{20}$ satisfy the inequality $t^2 + 9t - 17 > 0$?

Solution. Consider the quadratic equation with roots t_1 and $t_2 = -\sqrt{37} - \sqrt{20}$:

$$t^2 + 2\sqrt{20}t - 17 = 0.$$

Since $2\sqrt{20} = \sqrt{80} < 9$, we conclude that

$$t_1^2 + 9t_1 - 17 > t_1^2 + 2\sqrt{20}t_1 - 17 = 0$$

(clearly, $t_1 > 0$).

Answer. The number t_1 satisfies this inequality.

It often proves much easier to calculate the value of a function at some point if you start by composing a polynomial that vanishes at that point. Here's an example.

Problem 3. Calculate $u^4 - 5u^3 + 6u^2 - 5u$, when $u = 2 + \sqrt{3}$.

Solution. Remember the result of problem 1: $u^2 - 4u + 1 = 0$, or

$u^2 = 4u - 1$. Using this relation, we can express u^3 and u^4 as linear functions of u :

$$\begin{aligned} u^3 &= u^2 u = (4u - 1)u = 4u^2 - u \\ &= 4(4u - 1) - u = 15u - 4, \\ u^4 &= u^3 u = (15u - 4)u = 15u^2 - 4u \\ &= 15(4u - 1) - 4u = 56u - 15. \end{aligned}$$

And thus,

$$\begin{aligned} u^4 - 5u^3 + 6u^2 - 5u &= 56u - 15 \\ &\quad - 5(15u - 4) + 6(4u - 1) - 5u = -1. \end{aligned}$$

Answer. -1 .

Taking this example for the model, we can represent the value of any polynomial with integer coefficients at a point $u = a + b\sqrt{d}$ in the form $ku + l$ (here a , b , d , k , and l are integers).

Problem 4. Demonstrate that the number $(7 + \sqrt{48})^{13} + (7 - \sqrt{48})^{13}$ is an integer and is divisible by 14.

Solution. The numbers $u = 7 + \sqrt{48}$ and $v = 7 - \sqrt{48}$ are the roots of the square trinomial $t^2 - 14t + 1$. Using the formulas $u^2 = 14u - 1$ and $v^2 = 14v - 1$, we obtain the following "recursive relations" for the values $a_n = u^n + v^n$:

$$\begin{aligned} a_0 &= 2, \\ a_1 &= u + v = 14, \\ a_2 &= u^2 + v^2 = (14u - 1) + (14v - 1) \\ &= 14a_1 - a_0, \\ a_3 &= u^3 + v^3 = u(14u - 1) + v(14v - 1) \\ &= 14a_2 - a_1, \\ &\vdots \\ a_n &= u^n + v^n \\ &= u^{n-2}(14u - 1) + v^{n-2}(14v - 1) \\ &= 14a_{n-1} - a_{n-2}. \end{aligned}$$

The fact that all the numbers a_n are integers follows directly from these formulas. In addition, we can show that for odd n , a_n is divisible by 14. We prove the latter statement by induction on n : If a_{n-2} is divisible by 14, then the last formula implies that a_n is also divisible by 14.

Problem 5. Calculate the value of $u^8 + 1/u^8$, if $u = \sqrt{2} + 1$.

(Answers and hints for problems 5, 10, 13, and the exercises can be found on page 54.)

Vieta's formulas for polynomials of arbitrary degree are obtained just as they are for quadratic polynomials. We write

$$\begin{aligned} P(t) &= (t - x_1)(t - x_2) \dots (t - x_n) \\ &= t^n + a_1 t^{n-1} + a_2 t^{n-2} + \dots + a_n, \end{aligned}$$

where x_1, x_2, \dots, x_n are its roots. We remove parentheses, collect like terms, and set equal the coefficients of equal powers of t on both sides.

Let's write these formulas explicitly for a third degree polynomial with roots x , y , and z :

$$\begin{aligned} P(t) &= (t - x)(t - y)(t - z) \\ &= t^3 + pt^2 + qt + r, \end{aligned}$$

$$\begin{aligned} p &= -x - y - z, \\ q &= xy + yz + zx, \\ r &= -xyz. \end{aligned} \quad (2)$$

Now we proceed to the most interesting problems illustrating the advantages of employing auxiliary polynomials. In all of these examples we consider the polynomials constructed for a set of three or more roots.

Problem 6. The numbers x , y , and z satisfy the relation

$$\begin{aligned} x + y + z &= a, \\ 1/x + 1/y + 1/z &= 1/a. \end{aligned}$$

Prove that at least one of these numbers must be equal to a .

Solution. Let's use formulas (2). We obtain

$$\begin{aligned} p &= -(x + y + z) = -a, \\ q &= xyz(1/x + 1/y + 1/z) \\ &= xyz/a = -r/a, \end{aligned}$$

and thus

$$\begin{aligned} P(t) &= t^3 - at^2 - (r/a)t + r \\ &= (t - a)(t^2 - r/a). \end{aligned}$$

So, one of the roots of the polynomial $P(t)$ is equal to a . And therefore, one of the numbers x , y , or z must be equal to a .

Problem 7. The sum of three integers u , v , and w vanishes. Prove that the number $2u^4 + 2v^4 + 2w^4$ is a square of an integer.

Solution. Let $P(t) = t^3 + pt^2 + qt + r$ be a polynomial with roots u , v , and w . According to Vieta's theorem,

$$p = -(u + v + w) = 0.$$

Therefore

$$\begin{aligned} u^3 + qu + r &= 0, \\ v^3 + qv + r &= 0, \end{aligned}$$

$$w^3 + qw + r = 0.$$

We want to obtain the expression given in the problem, so we multiply these formulas by $2u$, $2v$, and $2w$, respectively, and add them. We get

$$2u^4 + 2v^4 + 2w^4 + 2q(u^2 + v^2 + w^2) = 0$$

(we've used the condition $u + v + w = 0$). But

$$u^2 + v^2 + w^2 = (u + v + w)^2 - 2(xy + yz + zx) = -2q.$$

Therefore

$$2u^4 + 2v^4 + 2w^4 = (2q)^2.$$

A similar technique works for the following problem, which often appears in mathematical Olympiads.

Problem 8. Decompose the following polynomial in x , y , and z

$$x^3 + y^3 + z^3 - 3xyz$$

into the product of two other polynomials.

Solution. Consider the polynomial $P(t) = t^3 + pt^2 + qt + r$ with roots x , y , and z (that is, $P(x) = 0$, $P(y) = 0$, $P(z) = 0$). Let's add the corresponding equalities:

$$\begin{aligned} x^3 + px^2 + qx + r &= 0, \\ y^3 + py^2 + qy + r &= 0, \\ z^3 + pz^2 + qz + r &= 0. \end{aligned}$$

Using Vieta's formulas (2) and the identity

$$\begin{aligned} x^2 + y^2 + z^2 &= (x + y + z)^2 - 2(xy + yz + zx) \\ &= p^2 - 2q, \end{aligned}$$

which we've used in the previous problem, we obtain

$$x^3 + y^3 + z^3 + p(p^2 - 2q) - qp + 3r = 0,$$

and thus

$$\begin{aligned} x^3 + y^3 + z^3 - 3xyz &= x^3 + y^3 + z^3 + 3r \\ &= -p(p^2 - 3q) \\ &= (x + y + z)(x^2 + y^2 + z^2 - xy - yz - zx). \end{aligned}$$

Remark. The quantity

$$x^2 + y^2 + z^2 - xy - yz - zx$$

is nonnegative (since

$$(x - y)^2 + (y - z)^2 + (x - z)^2 \geq 0).$$

Thus the identity we've proved implies the inequality

$$\frac{a+b+c}{3} \geq \sqrt[3]{abc}, \quad (3)$$

which connects the arithmetic and geometric means of three nonnegative numbers. It's sufficient to set $x = \sqrt[3]{a}$, $y = \sqrt[3]{b}$, and $z = \sqrt[3]{c}$ in inequality (3).

Now let's show how auxiliary polynomials help solve systems of equations.

Problem 9. Solve the system of equations

$$\begin{cases} x + y + z = 2 \\ x^2 + y^2 + z^2 = 14 \\ x^3 + y^3 + z^3 = 20. \end{cases}$$

Solution. Continuing with the methods we've developed, we start by considering the following polynomial:

$$\begin{aligned} P(t) &= (t - x)(t - y)(t - z) \\ &= t^3 + pt^2 + qt + r. \end{aligned}$$

According to Vieta's theorem,

$$p = -(x + y + z) = -2,$$

$$q = xy + yz + zx$$

$$= \frac{(x + y + z)^2 - (x^2 + y^2 + z^2)}{2} = -5.$$

To calculate the coefficient r , we multiply the equations of the system by q , p , and 1, respectively, and add them. Since $P(x) = P(y) = P(z) = 0$, we obtain

$$\begin{aligned} -3r &= 2q + 14p + 20 \\ &= -10 - 28 + 20 = -18. \end{aligned}$$

Consequently, $r = 6$ and

$$P(t) = t^3 - 2t^2 - 5t + 6.$$

We can see that the number 1 is a root of this polynomial (we invite the reader to check this). Now we can factor $P(t)$:

$$\begin{aligned} P(t) &= (t^3 - t^2) - (t^2 - t) - (6t - 6) \\ &= (t - 1)(t^2 - t - 6). \end{aligned}$$

Therefore, its roots are 1, -2, and 3.

Answer. (1, -2, 3); (1, 3, -2); (-2, 1, 3); (-2, 3, 1); (3, 1, -2); (3, -2, 1).

Problem 10. Solve the system of equations

$$\begin{cases} xyz = 1 \\ x + y + z = xy + yz + zx \\ x^3 + y^3 + z^3 = 73/8. \end{cases}$$

The method that we consider here proves efficient in many problems involving inequalities. Here are several examples.

Problem 11. The numbers u , v , w , x , y , and z satisfy the following relations:

$$\begin{aligned} x + y + z &= u + v + w, \\ xyz &= uvw, \end{aligned}$$

$$0 < u \leq x \leq y \leq z \leq w, u \leq v \leq w.$$

Prove that $u = x$, $v = y$, $w = z$.

Solution. Consider the two polynomials

$$\begin{aligned} P(t) &= (t - x)(t - y)(t - z) \\ &= t^3 + pt^2 + qt + r, \end{aligned}$$

and

$$\begin{aligned} Q(t) &= (t - u)(t - v)(t - w) \\ &= t^3 + pt^2 + kt + r \end{aligned}$$

(according to Vieta's theorem, the constant terms and the coefficients at t^2 of these polynomials must be equal). Set $R(u) = P(t) - Q(t) = (q - k)t$. Then

$$R(u) = P(u) = (u - x)(u - y)(u - z) \leq 0.$$

On the other hand, $R(t) = (q - k)u$, and thus $q - k \leq 0$. Similarly,

$$R(w) = P(w) = (w - x)(w - y)(w - z) \geq 0,$$

and therefore $q - k \geq 0$. Thus, we conclude that $q = k$, and the polynomials $P(t)$ and $Q(t)$ are equal. So, the sets of their roots coincide. We finish the proof by taking into consideration the inequalities given in the problem statement.

Problem 12. (This problem was proposed to the participants of the XXV International Mathematical Olympiad (1984) in Prague.) Prove that the following inequalities hold for all nonnegative x , y , and z such that $x + y + z = 1$:

$$0 \leq xy + yz + zx - 2xyz \leq 7/27.$$

Solution. It is not difficult to prove the first (left-hand) inequality:

$$\begin{aligned} xy + yz + zx - 2xyz &= xy(1 - z) + yz(1 - x) + zx \geq 0. \end{aligned}$$

To prove the second inequality, let's consider the polynomial

$$P(t) = (t-x)(t-y)(t-z) \\ = t^3 - t^2 + qt + r,$$

where $q = xy + yz + zx$, $r = -xyz$. Let's rewrite the inequality as follows:

$$q + 2r \leq 7/27.$$

Since

$$P\left(\frac{1}{2}\right) = -\frac{1}{8} + \frac{1}{2}q + r = -\frac{1}{8} + \frac{1}{2}(q + 2r),$$

it is enough to demonstrate that $P(1/2) \leq 1/216$. If none of the numbers x , y , and z exceed $1/2$, then, by the arithmetic-geometric mean inequality (3), we have

$$P\left(\frac{1}{2}\right) = \left(\frac{1}{2}-x\right)\left(\frac{1}{2}-y\right)\left(\frac{1}{2}-z\right) \\ \leq \left(\frac{\frac{1}{2}-x + \frac{1}{2}-y + \frac{1}{2}-z}{3}\right)^3 = \left(\frac{1}{6}\right)^3 = \frac{1}{216}.$$

And if one of these numbers is greater than $1/2$ (there can only be

one such number, of course), then

$$P\left(\frac{1}{2}\right) = \left(\frac{1}{2}-x\right)\left(\frac{1}{2}-y\right)\left(\frac{1}{2}-z\right) \leq 0.$$

We conclude our article with several problems involving polynomials with degrees greater than three.

Problem 13. Solve the system of equations

$$\begin{cases} x_1 + x_2 + \dots + x_n = n \\ x_1^2 + x_2^2 + \dots + x_n^2 = n \\ x_1^3 + x_2^3 + \dots + x_n^3 = n \\ \vdots \\ x_1^n + x_2^n + \dots + x_n^n = n \end{cases}$$

(here x_1, x_2, \dots, x_n are regarded as complex numbers).

An attentive reader might have noticed that all of the problems we've considered dealt with so-called "symmetric polynomials": the same sorts of polynomials discussed in *Gradus ad Parnassum* in the three previous issues of *Quantum*.

Exercises.

1. Prove that $\phi^8 = 13 - 21\phi$ if $\phi = (1/2)(1 - \sqrt{5})$.

2. The sum of the lengths of the edges of a rectangular parallelepiped is 96 cm, its surface area is 286 cm², and its volume is 120 cm³. Calculate the lengths of its edges.

3. Solve the system of equations

$$\begin{cases} x + y + z = 1 \\ x^2 + y^2 + z^2 = 3 \\ x^5 + y^5 + z^5 = 1. \end{cases}$$

4. Factor the polynomial in the form of the product:

$$(x-y)^5 + (y-z)^5 + (z-x)^5.$$

5. The positive numbers x , y , and z satisfy the inequalities

$$xyz > 1, \\ x + y + z < 1/x + 1/y + 1/z.$$

Show that one and only one of these numbers is less than 1. \blacksquare

ANSWERS, HINTS & SOLUTIONS
ON PAGE 54

Books for People Who Like Numbers!

If you like math—math puzzles, "brain teasers," and the inside stories behind big events in the history of mathematics—you will love these books by Eli Maor. He is a born teacher and a terrific guide for these mathematical mystery tours. Leave your computer and calculator behind and curl up with some good books. Eli Maor makes learning fun!

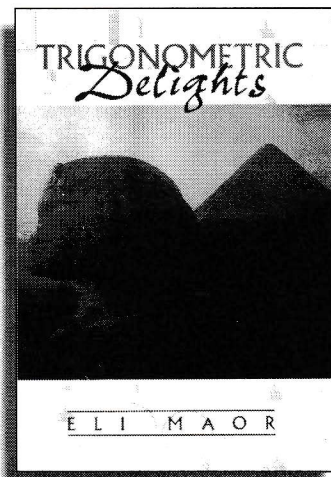

Trigonometric Delights

It's no secret that trigonometry can be boring—but not in the hands of Eli Maor! This isn't a formulaic look at sines, cosines, and tangents. It's a collection of stories, curiosities and insights, illustrated with over 100 fascinating drawings. Cloth \$24.95 ISBN 0-691-05754-0

e: The Story of a Number

How are the arrangement of seeds in a sunflower, the interest earned on a bank account, and the shape of the Gateway Arch in St. Louis all connected? The answer lies in the mysterious number called e . Here is e 's "biography." The prestigious magazine, *Science*, compares this well-illustrated book to "the voyages of Columbus as told by the first mate."

Paper \$14.95 ISBN 0-691-05854-7

To Infinity and Beyond

This book addresses a question that mathematicians have asked for perhaps thousands of years: how can we possibly understand infinity? Eli Maor has the answer—or at least the story of how humans have grappled with this elusive concept throughout recorded history.

Paper \$16.95 ISBN 0-691-02511-8

Princeton University Press

AT FINE BOOKSTORES OR CALL 800-777-4726 • HTTP://PUP.PRINCETON.EDU

Magnetic fieldwork

by D. Tselykh

IN PHYSICS COURSES, STUDENTS learn the methods that allow us to measure the energy of electric field U_e . For example, we can discharge a capacitor of capacitance C initially charged to a voltage V through a resistor R and a microammeter. By plotting the graph of the dependence of electric power P on time, we can determine the amount of heat Q dissipated in the resistor during the discharge of the capacitor, which is equal to the area under the curve. According to the conservation of energy, this amount of heat is determined by the energy stored in the capacitor's electric field

$$U_e = \frac{CV^2}{2}.$$

However, students are not usually shown how the energy stored in a magnetic field is measured. We will try to fill in this gap. It is known that a current-carrying wire generates a magnetic field whose energy is determined by the current I and the inductance L of the wire:

$$U_m = \frac{LI^2}{2}.$$

This formula can be obtained in the simplest way by analogy between the phenomena of inertia and self-inductance. Inertia dictates that a body cannot immediately gain a

certain value of velocity when affected by a force; its velocity increases gradually. In the same way, closing a circuit cannot produce an immediate increase in current; self-inductance causes it to grow gradually also.

In electrodynamics the quantity that is analogous to the mechanical velocity v is the current I , which describes the motion of electric charges. The analogue of the mass m is the (self-) inductance L , since L is the value that determines the rate of change of the electric cur-

rent variation. Therefore, the energy of a magnetic field should be analogous to the kinetic energy of the translational motion of a moving body $mv^2/2$ —that is, $LI^2/2$. A more rigorous derivation of this formula is based on calculating the work of the self-induced emf during the change of electric current in the circuit. Try this derivation on your own.

This theoretical result can be tested experimentally. The energy of a magnetic field can be found from the amount of dissipated heat. The experimental design is as follows: Self-induced current in the electric circuit (figure 1) results in the dissipation of heat in the resistance R_h , and the amount of dissipated energy is equal to the loss of magnetic field energy. When the circuit is closed, the current travels only across the coil with inductance L , since the diode D is connected in reverse with respect to the polarity of the battery. When the circuit is open, the current passes through the resistance, dissipating heat.

The amount of dissipated heat is measured by a thermoscope (figure 2), which is made of a test tube that contains a heating coil (our resistor R_h) and a capillary tube with a column of liquid. When current passes through the heating coil, it warms the air in the test tube and therefore displaces the column some distance Δx . The amount of heat obtained by the air in the test tube is determined

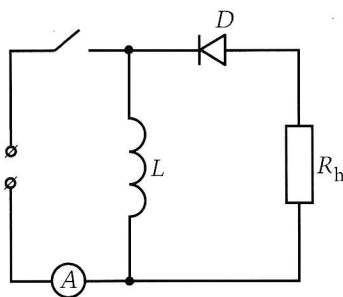

Figure 1

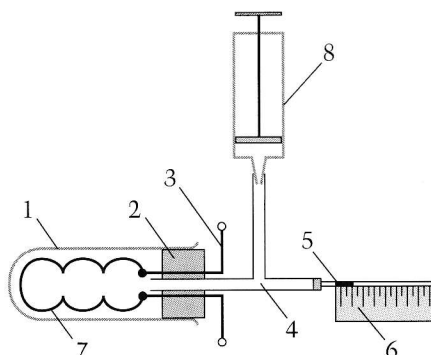

Figure 2

by the formula

$$Q = cm\Delta T,$$

where m is the mass of air in the tube, c is the specific heat of air, and ΔT is the change in temperature, which can be found from the ideal gas law. As heating takes place at constant pressure P , the temperature change is related to the change of volume ΔV according to the formula

$$P\Delta V = \frac{m}{M}R\Delta T,$$

where M is the molar mass of air and R is the gas constant. We also have

$$\Delta V = S\Delta x = \frac{\pi d^2}{4}\Delta x,$$

where d is the diameter of the capillary tube. Inserting the tempera-

ture increment determined by this formula into the equation for Q , we get

$$Q = \frac{P\pi d^2 \Delta x c M}{4R}.$$

Thus, the amount of heat dissipated in the thermoscope is directly proportional to the displacement Δx of the liquid column.

We must now recall that the inductance coil is made of wire and thus also has a resistance R_c . Therefore, the amount of heat obtained by the air in the test tube is more correctly determined by the formula

$$Q = \frac{U_m R_h}{R_h + R_c},$$

which shows that the energy of the magnetic field U_m is also directly proportional to the displacement Δx

of the liquid column in the capillary tube of the thermoscope.

In our experiments we used diode D226B, a choke coil with 3600 turns, and a core (which can be found in a school lab). The heating coil R_h was made of constantan wire 0.05 mm in diameter and 35–40 cm in length. The thermoscope (figure 2), which measures heat energy, consists of a test tube (1), rubber stopper (2), copper wires (3), T-tube (4), the capillary tube (from an alcohol thermometer) with liquid column (5), a scale (6), constantan spiral (7), and syringe (8) (the syringe is needed for adjusting the position of the liquid column in the capillary tube).

The experiment should be repeated several times with different values of the current I in the induction coil (that is, with various values of the initial stored magnetic energy). The results of this experiment are given in figure 3.

The plot of the displacement Δx versus the square of the current I^2 (figure 4), which determines the energy of the magnetic field, shows that the displacement is almost directly proportional to the energy of the magnetic field, which corresponds to our previous theoretical reasoning.

Repeating this experiment with different induction coils shows that the displacement Δx of the liquid column is directly proportional to the inductance L if the strength of the current is the same in all tests. Now we only need to calibrate our device using a coil with a known inductance to finish our homemade magnetometer. \blacksquare

Quantum articles about magnetic fields:

Kaleidoscope, "Electromagnetic induction," March/April 1991, pp. 32–33.

A. Mitrofanov, "Can you see the magnetic field?" July/August 1997, pp. 18–22.

A. Stasenko, "Magnets, charges, and planets," May/June 1997, pp. 42–45.

J. Wylie, "Magnetic monopoly," May/June 1995, pp. 4–9.

I (mA)	50	70	90	110	140	180	230	290	350
Δx (mm)	1	2	3	4	7	11	16	28	41

Figure 3

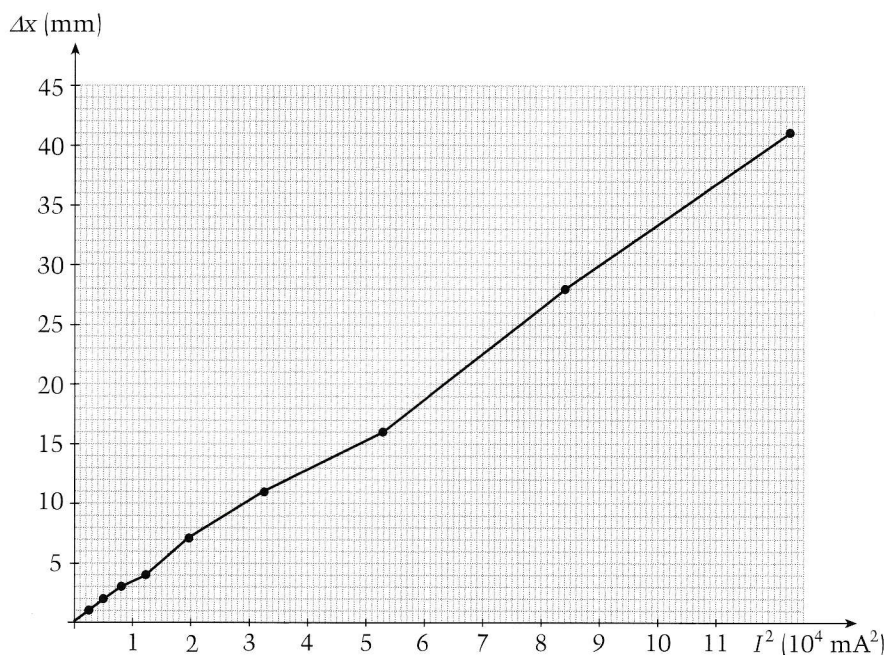

Figure 4

In focus

by A. Dozorov

WHEN WE AIM A CAMERA and bring the picture into sharp focus, we are positioning the optical image exactly on the emulsion layer of the film. To focus a movie at the cinema, the projectionist must make the image coincident with the plane of the screen. However, the concept of definition (sharpness) becomes somewhat unfocused when no screen is needed for observation (for example, when an object is regarded with the unaided eye).

Let's try a simple experiment. Look out the window. The distant objects appear clear. Now look at the objects located several meters from you. The definition (sharpness) is also high. Moreover, when reading this page, you have a sharp image of the text as well! This is possible because your eyes are automatically adjusted for sharpness. The adjustment is performed by your brain with the help of ciliary muscles that deform the pliable

crystalline lenses in your eyes, a process known as *accommodation*. As a result, the optical image is made to lie on the retina (the biological "screen"), and your vision is clear (fig. 1).

In other words, although the distance d to the object varies, the distance d' between the lens and the image (retina) doesn't change. This is possible only when the focal length f of the crystalline lens varies according to the lens formula:

$$\frac{1}{d} + \frac{1}{d'} = \frac{1}{f'}$$

or

$$\frac{1}{d} + \frac{1}{d'} = P.$$

where $P = 1/f$ is the optical power of the lens. The unit of optical power is the diopter when the focal length is given in meters.

When an eye views a distant object ($1/d \rightarrow 0$), the accommodation muscles are virtually at rest. In this case, $f = d'$ and $P = 1/d'$. Usually the distance d' between the crystalline lens and the retina is about 3 cm, so $f = 3$ cm and $P = 33$ diopters. When an object approaches the eye, the accommodation muscles start to work: They decrease the focal length of the lens according to the lens formula; the lens becomes more convex. When an object is placed at the distance of most comfortable vision (about 25 cm), the optical power of the lens is 37 diopters.

A further decrease of the distance between the eyes and an object overstrains the accommodation muscles. They can't work properly, and the image is no longer focused on the retina and becomes blurred. If the accommodation muscles are rather strong, the optical power can be enhanced up to 43 diopters to see an object from a distance of only 10 cm. In this case the smallest details can be viewed best, but the eyes get tired very quickly. Thus, the distance of comfortable vision corresponds to the optimal case, when the small details of an object can be viewed quite clearly without overstraining the accommodation muscles.

Now let's consider the case when the eye is assisted by a system of lenses—say, by a microscope. The optical system of a microscope creates a magnified virtual image $A'B'$ of an object AB (fig. 2). Sometimes when looking at an object through a microscope, we cannot see it clearly

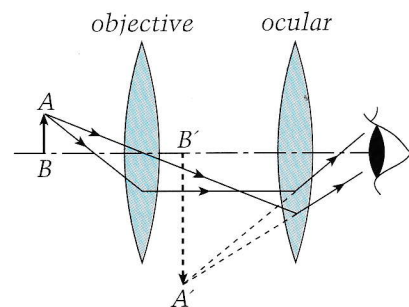
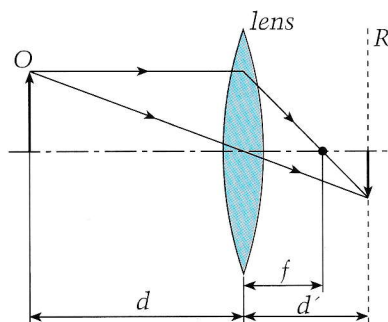

Figure 2. The optical system of a microscope. The magnified and inverted virtual image $A'B'$ of the object AB is viewed by observer's eye.

(its definition is low). Why can't the eye produce a clear image in this case? And what happens when we adjust the microscope for sharpness? What do we do by shifting the microscope's ocular lens?

The point is that the virtual image is formed by the system of lenses too close to the eye, so either the eye or the image should be moved to meet the requirements of the accommodation muscles. These conditions are known—the image should be positioned at the distance of most comfortable vision. If we simply move our eye away from the ocular lens, most of the light rays from the image will not hit the eye, and the projection on the retina will be degraded both in scope and brightness. Therefore, it is far better to shift the image rather than the eye. This can be done easily by changing the distance between the objective and ocular lenses. This is just what we do when adjusting a system of lenses for sharpness.

Until now we have tacitly supposed that the object is planar. In reality, most objects are three-dimensional, but their images in any optical system are planar.

Let's draw the images of points *A*, *B*, and *C* of the same object that are located at different distances from the lens (fig. 3). Each image lies in a different plane. If the screen is positioned so the image of point *B* is unblurred, the images of points *A* and *C* will appear not as points but

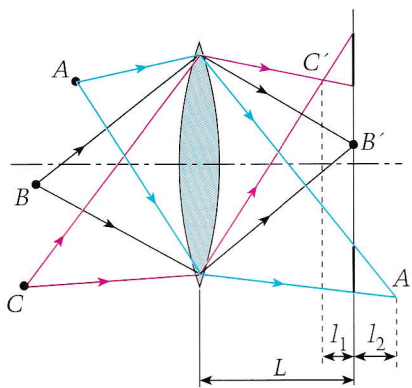

Figure 3. The effect of beam width on the depth of focus. The narrower beams provide higher definition of the images of the points *A* and *C*.

rather as disks known as "circles of confusion." The size of the circle of confusion is related to the size of the lens: the smaller the lens's diameter, the less blurred are the images *A'* and *C'*. Therefore, narrow light beams are the best tools for focusing the images of points that are at different distances from the lens. In other words, decreasing the diameter of the light beam (aperture) improves the depth of focus. What does this mean?

When a person views a disk with unaided eyes, the disk is perceived as a point (its image is clear) if the angular magnitude of the disk is about $1' \cong 3 \cdot 10^{-4}$ rad. Usually we observe an object from the most comfortable distance $l_0 = 25$ cm. In this case, the maximum diameter of the circle is

$$2r = l_0 \tan \alpha \cong l_0 \alpha \cong 75 \cdot 10^{-4} \text{ cm} = 0.075 \text{ mm.}$$

Let points *A* and *C* (fig. 3) be projected onto the screen as circles of confusion of the same radius *r*. In this case, the geometrical range of sharp images (the distance between the planes on which points *A* and *C* can be projected as points rather than circles of confusion) is equal to

$$l_1 + l_2 \cong \frac{2rl}{D_1} \cong \frac{Ll_0\alpha}{D_1},$$

where *L* is the distance between the lens and the object and D_1 is the lens's diameter. This value is referred to as the depth of focus (not to be confused with the depth of field). The formula shows that the depth of focus is inversely proportional to the width of the beam.

Since the different points of the object correspond to different circles of confusion in the image, it is important that these circles do not overlap. If the adjacent circles do not overlap, they are perceived as separate entities. In this case, the optical system is said to *resolve* these two points. On the contrary, when the circles are superimposed, the resulting image consists of a single spot, or in other words, the points are not resolved by the system. A decrease

in the lens's diameter leads to smaller circles of confusion and thus to an increase in resolving power. If the lens's diameter is large, the resolving power becomes low, and instead of a sharp image we get a blurred spot. Thus, minimizing aperture (beam width) is very important for obtaining a sharp image of an object.

In any optical system the light beam is limited in diameter, by lens mounts or special diaphragms of variable diameter. In the eye, the role of such a diaphragm is played by the iris, which has an orifice of variable diameter, the pupil.

However, there is another side of the coin: Minimizing the aperture results in a decrease in the luminous flux coming into the optical system. Therefore, the image is dimmer. Take a common camera as an example. In many cases, people photograph distant objects, so the corresponding images lie exactly in the focal plane of the objective. In this case, image illumination—the ratio of luminous flux to image area—becomes proportional to the square of the ratio of the diameter of the objective to its focal length (check this on your own). The ratio of the diameter of the objective to the focal length is known as the *f* number.

Therefore, an increase in the depth of focus leads to a decrease in the brightness of the image. High-performance objective lenses provide bright images with high definition.

In closing we must note that we have considered the problem of depth of focus and resolving power only within the framework of geometrical optics. In reality, such phenomena as light diffraction, defects of optical systems, and chemical properties of the light-sensitive layer also play significant roles. ■

Quantum articles about art and the depth of photography:

M. L. Biermann, "Clarity, reality, and the art of Photography," September/October 1995, pp. 26–31.

ANSWERS, HINTS & SOLUTIONS

Math

M241

If x is real, it must be nonnegative. In fact, since the left side of the given equation is positive, $x^3 > 100$. Thus we can transform the given equation to

$$x = \sqrt{\sqrt{(x^3 - 100)^3} - 100}.$$

The equation has obtained the form $x = f(f(x))$, where $f(x) = \sqrt{x^3 - 100}$, a monotonically increasing function. For such functions, the equations $x = f(f(x))$ and $x = f(x)$ are equivalent (we will prove this later). Thus we obtain the equation $x = \sqrt{x^3 - 100}$ or $x^3 - x^2 - 100 = 0$. The left-hand side of this equation can be factored. We can write the equation as

$$(x^3 - 125) - (x^2 - 25) = 0,$$

and therefore as

$$(x - 5)(x^2 + 4x + 20) = 0$$

(by factoring the difference of two squares and of two cubes). Thus both this equation and the original one have the unique real solution $x = 5$.

Let us now prove the auxiliary proposition. Consider the two equations

$$x = f(f(x)) \quad (1)$$

and

$$x = f(x), \quad (2)$$

where $f(x)$ is a monotonically increasing function. We can see that any root of the second equation is also a root of the first equation (for this to be true, monotonicity is not required). We will show that a root of the first equation is also a root of

the second. Let x_0 be a root of equation (1). Assume that x_0 does not satisfy equation (2). Then, either $x_0 > f(x_0)$ or $x_0 < f(x_0)$. Let $x_0 > f(x_0)$. Because of the monotonicity of $f(x)$, we have

$$x_0 > f(x_0) > f(f(x_0)),$$

which contradicts the assumption that x_0 is a root of equation (1). A similar argument works if $x_0 < f(x_0)$.

M242

Let's prove that K is the center of the circle circumscribed about triangle BMC . Indeed,

$$\begin{aligned} \angle BKC &= 180^\circ - 2\angle KBC \\ &= 180^\circ - 2(90^\circ - \angle BMA) \\ &= 2\angle BMA = 360^\circ - 2\angle BMC. \end{aligned}$$

Since $\angle BMC$ is obtuse, this means that K is the center of the circle circumscribed about triangle BMC . Let P be the point of intersection of KM and AD (see fig. 1). Since K is the center of the circle through B , M , and C , we have $\angle MBC = \frac{1}{2}\angle MKC$. Also,

$$\begin{aligned} \angle AMP &= \angle KMC = 90^\circ - \frac{1}{2}\angle MKC \\ &= 90^\circ - \angle MBC = 90^\circ - \angle MAP \end{aligned}$$

(the last because $\angle MBC$ and $\angle MAP$ intercept the same arc on circle $ABCD$). Examining triangle AMP , we find that $\angle APM = 90^\circ$.

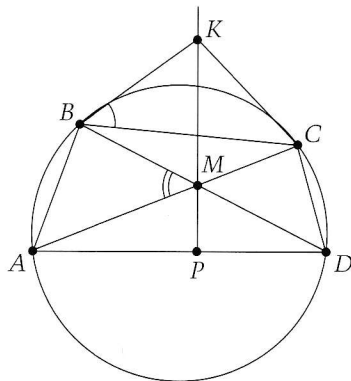

Figure 1

M243

Part (a): See figure 2. From its starting point A , which is 1 km from the center of the circle of fire, the bulldozer can go 1 km along a radius of the circle and then goes along the circle of radius 2 km with its center at O . The total route length is $1 + 4\pi < 14$ km. This means that the fire would not be able to travel 1 km in this time, so a circle with an area of 4π km² will be burned.

Part (b): See figure 3. From its starting point at A , the bulldozer can go 0.5 km along a radius of the circle of fire to a point B and then along arc BC (of the circle with radius of 1.5 km centered at O) with a central angle of $4\pi/3$. Then it can proceed along radius CD (of the circle with radius 2 centered at O) for 0.5 km, then along arc DE (of the same circle) with a central angle of $2\pi/3$. It can complete its route by traveling along arc EF of the circle centered at B with radius 0.5 km (where F lies on the circle centered at O with radius 1.5 km).

In order to prove that the route described cuts off the fire, we can

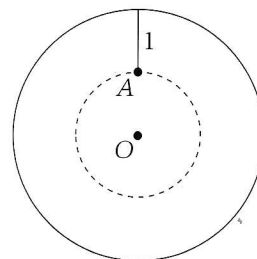

Figure 2

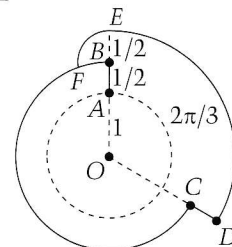

Figure 3

prove that the fire cannot travel more than 0.5 km while the bulldozer travels from A to C , and it cannot travel more than 1 km before the bulldozer completes its route. This is equivalent to proving that the length of the route from A to C is not greater than 7, and the length from A to F is not greater than 14. The length of the route from A to F is not greater than 14. The length of the route from A to C is

$$0.5 + \frac{4\pi}{3} \cdot \frac{3}{2} < 7.$$

To estimate the length of the path from A to F , we must show that $\angle EBF < 2\pi/3$. To see this, note that triangle OFB is isosceles. If BF were equal to 1, triangle OFB would be equilateral, and $\angle EBF$ would be $2\pi/3$. Since $BF = 0.5 < 1$, we see that $\angle FBO > \pi/3$, so $\angle EBF < 2\pi/3$.

Now we can assert that the length of the path from A to F is

$$0.5 + \frac{4\pi}{3} \cdot \frac{3}{2} + 0.5 + \frac{2\pi}{3} \cdot 2 + \frac{2\pi}{3} \cdot \frac{1}{2} < 14.$$

Let us evaluate the area S enclosed by the bulldozer:

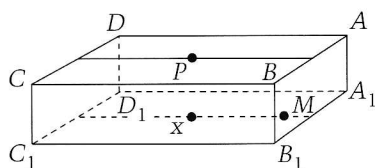

Figure 4

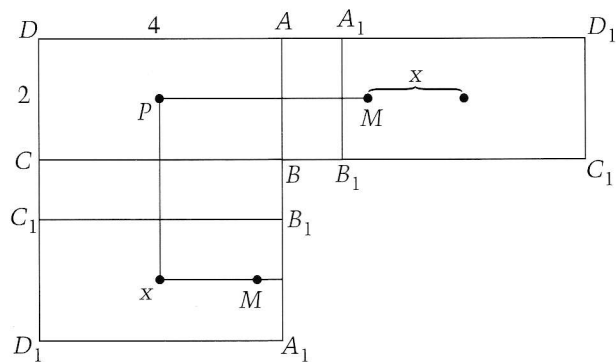

Figure 5

M244

Figure 4 shows a rectangular parallelepiped $ABCD A_1 B_1 C_1 D_1$, where $AB = 2$, $BC = 4$, and $AA_1 = 1$. Let P be the center of the face $ABCD$ (fig. 4), where the Prince's house is situated. Let's find a point on the segment connecting the midpoints of the small sides of the opposite face, such that the shortest path from P to this point passing through the edges BC and $B_1 C_1$ is equal to the shortest path passing through the edges AB and $A_1 B_1$. Let this point, M , be situated at a distance x from the center of the face $A_1 B_1 C_1 D_1$. We claim that no point on Brick is farther from P than M .

First let us find the shortest distance from P to M . Figure 5 shows two developments of the parallelepiped. From them, we obtain the equation

$$5 - x = \sqrt{9 + x^2},$$

from which we find that $x = 1.6$. For

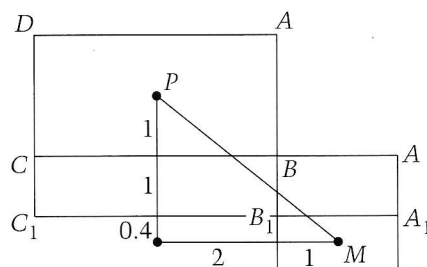

Figure 6

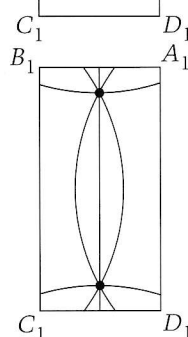

Figure 7

this x , the length of each of the paths under consideration (from P to M) equals 3.4.

We must now prove that any path from P to M is equal to 3.4; it is sufficient to prove that any path from P to M that crosses BB_1 (or AA_1) is longer than 3.4. It is easy to see that any path that crosses the edge AB cannot be shorter than 3.4. Any path that goes through BC and BB_1 has the length $\sqrt{3^2 + 2.4^2} > 3.4$ (fig. 6). Thus no path from P to M is shorter than 3.4.

Now we must show that no other point on this face is closer to P . To prove this, it is sufficient to consider only those paths that cross the edges BC and $B_1 C_1$, and paths that cross the edges AB and $A_1 B_1$, as well as paths that cross opposite pairs of edges. The corresponding four circles of radius 3.4 cover the entire face $A_1 B_1 C_1 D_1$ (fig. 7). The fact that the distance to any point on the other four faces from P is less than 3.4 is fairly evident. Indeed, the vertices of these faces that are also the vertices of the face $A_1 B_1 C_1 D_1$ are farthest from P . Thus, the distance from the Prince of Brick's house to the farthest point on the planet is 3.4.

M245

Consider the polynomial

$$P(x) = (x - a)(x - b)(x - c) = x^3 - 7x^2 + px - 9,$$

where $q = ab + bc + ca$. The roots of this polynomial are a , b , and c . From the equation $P(x) = 0$, we obtain

$$q = -x^2 + 7x + 9/x.$$

Plot this function for $x > 0$ (fig. 8). The variable q may take only those

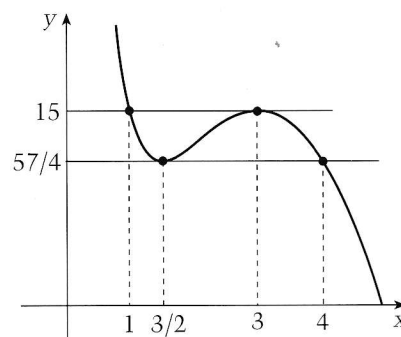

Figure 8

values for which the lines $y = q$ intersect the curve at three points with abscissas a , b , and c (two of them may coincide, in which case the corresponding line is tangent to the curve). Differentiating, we have

$$q' = -2x + 7 - 9/x^2.$$

Find the roots of this derivative. We have the equation

$$2x^3 - 7x^2 + 9 = 0,$$

or

$$(x + 1)(2x^2 - 9x + 9) = 0.$$

Since we are interested only in positive values of x , we obtain $x_1 = 3/2$ and $x_2 = 3$. The original function $q(x)$ has a minimum at the point $x_1 = 3/2$ that is equal to $57/4$, and $q(x)$ has a maximum at the point $x_2 = 3$ that equals 15. The line $q = 57/4$ touches our curve at the point $(3/2, 57/4)$ and intersects it at the point $(4, 57/4)$. This intersection point can be found from the equation

$$-x^2 + 7x + 9/x = 57/4,$$

which can be transformed to

$$(2x - 3)^2(x - 4) = 0.$$

The line $q = 15$ touches the curve at the point $(3, 15)$ and intersects it at the point $(1, 15)$. This intersection point can be found from the equation

$$-x^2 + 7x + 9/x = 15,$$

which can be transformed to

$$(x - 3)^2(x - 1) = 0.$$

Thus, we obtain the constraints on the numbers a , b , and c :

$$\begin{aligned} 1 &\leq a \leq 3/2, \\ 3/2 &\leq b \leq 3, \\ 3 &\leq c \leq 4. \end{aligned}$$

The reader can check that all these values are indeed possible.

Physics

P241

Glycerin is a very viscous liquid, so we can assume the bubble's speed

relative to the tube (that is, in the dynamic frame of reference) is at any moment proportional to the acceleration of the tube (and the bubble!) relative to Earth, because the force of viscous friction is proportional to the relative speed. Taking into account the relationship between the acceleration, speed, and displacement of a point, we can say that the displacement of the bubble relative to the tube is related to its speed (in this frame of reference) in the same way as the tube's speed is related to its acceleration in the lab system.

The motion of the bubble in the vertical tube is just the same as in the horizontal tube, provided the latter is moved with a constant acceleration of $a = g = 10 \text{ m/s}^2$. Remember that the bubble's velocity has the same direction as the acceleration, because glycerin is lighter than water. We have the following data: During the first second of its motion, the tube acquires a speed of 10 m/s and an acceleration of 10 m/s^2 , and the bubble will be displaced 1 cm . Thus, the speed of 10 m/s corresponds to a 1 cm shift of the bubble. Accordingly, when the tube gains a velocity of 20 m/s , the bubble will be 2 cm from its initial position. When the tube's speed is further increased to 30 m/s , the bubble will move 1 cm more, but when the tube is stopped, the bubble will assume its initial position. It seems that the tube and bubble operate like a measuring device. What does it measure?

P242

According to the equation $P = nkT$, the concentration n of helium atoms is determined by its temperature T and pressure P (k is the Boltzmann constant). Therefore, a line passing through the origin of the temperature-pressure coordinates corresponds to a larger concentration of atoms if it is drawn at a smaller angle to the P -axis. Accordingly, in the process shown in figure 9, the maximum concentration is achieved at point B and the minimum concentration at point A (the figure is drawn in the reduced coordinates $\tau = T/T_0$ and $\delta = P/P_0$). The figure

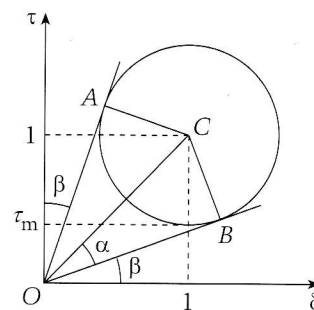

Figure 9

shows that

$$n_{\max} = \frac{P_B}{kT_B} = \frac{P_0 \cot \beta}{kT_0},$$

where β is the inclination of the tangent BO to the δ -axis on the reduced diagram. Since $\triangle ACO = \triangle BCO$, the angle between the tangent AO and the τ -axis on the reduced diagram is also β , so

$$n_{\max} = \frac{P_A}{kT_A} = \frac{P_0 \tan \beta}{kT_0}.$$

Therefore, the concentration ratio is

$$\frac{n_{\min}}{n_{\max}} = \tan^2 \beta.$$

If we take into account that the minimum reduced temperature $\tau_m = T_m/T_0$ of helium and the radius r of the circle corresponding to the given process are bound by the equation $r = 1 - \tau_m$, we get $\sin \alpha = r/\sqrt{2}$, because $\triangle CBO$ is a right triangle and its hypotenuse $OC = \sqrt{2}$. The figure shows that $\alpha + \beta = \pi/4$, from which we obtain

$$\begin{aligned} \frac{n_{\min}}{n_{\max}} &= \tan^2 \beta = \tan^2 \left(\frac{\pi}{4} - \alpha \right) \\ &= \left(\frac{1 - \tan 2\alpha}{1 + \tan 2\alpha} \right)^2 = \frac{1 - \sin 2\alpha}{1 + \sin 2\alpha} \\ &= \frac{1 - r\sqrt{2 - r^2}}{1 + r\sqrt{2 - r^2}} \\ &= \frac{1 - (1 - \tau_m)\sqrt{2 - (1 - \tau_m)^2}}{1 + (1 - \tau_m)\sqrt{2 - (1 - \tau_m)^2}} \\ &= \frac{1 - (1 - \tau_m)\sqrt{1 + 2\tau_m - \tau_m^2}}{1 + (1 - \tau_m)\sqrt{1 + 2\tau_m - \tau_m^2}}. \end{aligned}$$

P243

At first glance, the problem is trivial. The thin wire is capable of carrying electric current up to $I_1 = 1.8$ A, while the maximum current of the thick wire is $I_2 = 5$ A. As the currents are summed for parallel connections, the maximum current of the combined fuse should be $I_1 + I_2 = 6.8$ A. However, this reasoning is based on the false premise that the total current of 6.8 A will be distributed as 1.8 A and 5 A between the thin and thick wires, respectively. In reality, the distribution will be quite different, since it is determined by the resistances of the wires and not by their maximum currents. Therefore, if the maximum current flows through one wire, the current in the other wire will be less than the maximum current of that wire. Therefore, the total current will be less than 6.8 A.

The first step of the correct solution is to determine which of the wires will melt first when current in the circuit is gradually increased. In a parallel connection, the voltage is the same across both wires. Thus, the wire with the smaller value of the maximum voltage will be blown first. Let's find the ratio of these maximum voltages. The length of the wires is denoted by l and the resistivity of lead is denoted by ρ_0 . The resistance of the first wire and its maximum voltage are

$$R_1 = \frac{\rho l}{\frac{\pi d_1^2}{4}}$$

and

$$V_1 = R_1 I_1 = \frac{\rho l I_1}{\frac{\pi d_1^2}{4}},$$

respectively. For the second wire, the resistance and maximum voltage are:

$$R_2 = \frac{\rho l}{\frac{\pi d_2^2}{4}}$$

and

$$V_2 = \frac{\rho l I_2}{\frac{\pi d_2^2}{4}}$$

The voltage ratio we are looking for is

$$\frac{V_1}{V_2} = \frac{I_1 d_2^2}{I_2 d_1^2}.$$

Plugging the numerical values into this equation yields $V_1/V_2 > 1$. Thus $V_2 < V_1$, which means that the second (thicker!) wire will blow first. At this moment it carries the maximum current $I_2 = 5$ A while the current in the first wire is only

$$I_1' = \frac{I_2 R_2}{R_1} = \frac{I_2 d_1^2}{d_2^2} = 1.25 \text{ A}.$$

Therefore, the total maximum current of the combined "fuse" will be

$$I_1' + I_2 = 6.25 \text{ A}.$$

Immediately after the thick wire blows, all the current will flow through the thin wire, and it will blow as well.

The second case is even more interesting. When the thick wire blows, each thin wire will carry the current I_1' , so the total current in the "fuse" will be

$$I'_{\text{tot}} = 20I_1' + I_2 = 30 \text{ A}.$$

Still this is not the answer to the problem: The fuse will continue to work with only the thin wires! In contrast to the first case, the current I'_{tot} will be equally distributed among all 20 wires, and every individual current will be less than the maximum current. Therefore, the fuse will work until the total current rises to the value

$$I'_{\text{tot}} = 20I_1 = 36 \text{ A}.$$

P244

Let's consider the ring as it lies horizontally (figure 10 gives the top view of the ring). We chose two small elements of length Δl located at points C and D symmetrical to

the ring's diameter AB. The first element is affected by the downward vertical force

$$\Delta F_1 = BI\Delta l \sin \alpha = BI\Delta x,$$

where Δx is the projection of Δl on the diameter AB. The second element is affected by the upward force

$$\Delta F_2 = BI\Delta l \sin \alpha = BI\Delta x.$$

These forces are equal in value and opposite in direction, so they form a force couple that produces a torque relative to the AB axis:

$$\Delta \tau = \Delta F_1 l_{CD} = BI\Delta x l_{CD} = BI\Delta S,$$

where ΔS is the area of the dashed region.

Now we divide the ring into the analogous pairs of small segments symmetrical to diameter AB. We find that a thin conducting ring carrying a current I located in a horizontal magnetic field B will be affected by the torque

$$\tau_{\text{magn}} = BIS = BI\pi R^2$$

due to the magnetic forces. This torque tries to turn the ring around the horizontal axis AB.

When the ring almost begins to rise, two forces will oppose its rotation: the downward vertical force of gravity mg applied at the ring's center and the upward normal force N applied at the supporting point of the ring. As the ring is still at equilibrium,

$$mg - N = 0, \text{ or } N = mg,$$

so the mechanical forces develop a force couple of their own, which produces the torque

$$\tau_{\text{mech}} = mgR.$$

At equilibrium, the total torque of all forces—that is, the sum of mag-

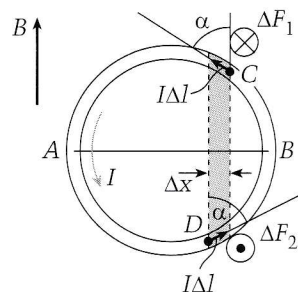

Figure 10

netic and mechanical torques—is equal to zero:

$$M_{\text{magn}} - M_{\text{mech}} = 0,$$

or

$$BI\pi R^2 - mgR = 0,$$

which yields the value of the electric current we are looking for:

$$I = \frac{mg}{\pi BR}.$$

P245

The plot in figure 11 shows that the cylinder's wall is 1 cm thick and its outer diameter is $d = 4$ cm. To solve the problem, we can just compare the intensity of radiation in the middle of the cylinder at $x = 2$ cm (here the ray passes through the cylinder's contents and two opposite parts of its wall with a total thickness of 2 cm) with the intensity of the radiation where the total thickness of the pierced metal is also 2 cm. If these values are identical, then the cylinder is empty.

The geometry (figure 12) yields

$$r^2 = h^2 + (r - x)^2,$$

where $r = d/2 = 2$ cm and $h = 1$ cm. Thus,

$$x_1 = 2 - \sqrt{3} \cong 0.28 \text{ cm},$$

$$x_2 = 2 + \sqrt{3} \cong 3.72 \text{ cm}.$$

The plot shows that at $x = 2$ cm

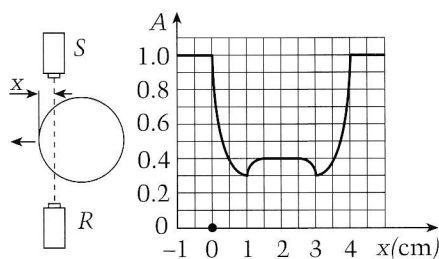

Figure 11

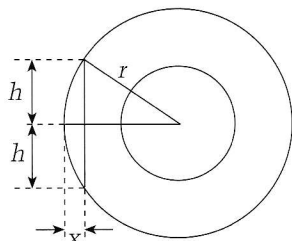

Figure 12

the intensity is 0.4 units, and at $x = x_1$ and $x = x_2$ it is about 0.5 units, which is somewhat larger. Therefore, the cylinder is not empty.

Brainteasers

B241

Sam is indeed correct. It is easy to find three numbers that satisfy the equation if you note that 365 is the number of days in a year (not a leap year), and 28, 30, and 31 are the possible numbers of days in a month. Thus, $x = 1, y = 4, z = 7$ is a solution.

B242

First we simultaneously light one piece of fuse at both ends and the second piece at one end. The first piece will burn in 30 seconds. As soon as it finishes burning, we light the second piece of fuse at its other end. The second fuse will burn for 15 more seconds, which completes the 45 seconds. We invite the reader to check that a variable rate of burning along each fuse makes no difference.

B243

To maximize the seven-digit number formed by dropping the commas, we would like to have as many 9's as possible as its leftmost digits. It is not difficult to see that four 9's are not possible: No matter how the remaining three digits are distributed to form two (positive) integers, the difference between them will be too small to yield the required arithmetic progression.

So we must try three 9's. Let the seven-digit number be 999ABCD (where juxtaposition of letters indicates place value). An argument similar to the one above will show that the third number must have a single digit, so that the arithmetic progression is 999, ABC, D. Then it follows that $D = 2(ABC) - 999$, and we want to maximize ABC. It is not hard to see that a maximal D will yield a maximal ABC, so we try $D = 9$. We quickly find the required sequence: 999, 504, 9.

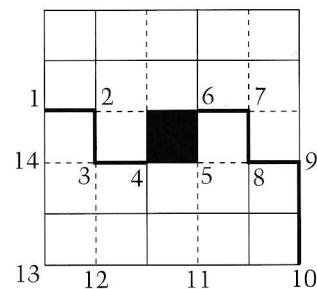

Figure 13. The solid lines indicate the cuts; the dotted lines the folds.

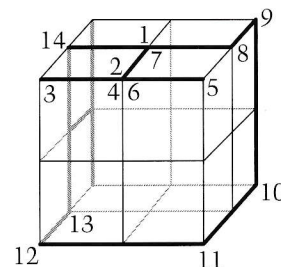

Figure 14. The bold line depicts the border of one of the parts.

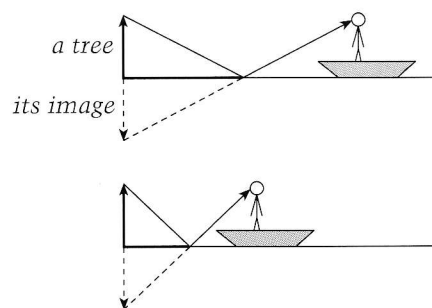

Figure 15

B244

A solution is illustrated in figures 13 and 14.

B245

The answer is given in figure 15.

Auxiliary polynomials

Problems.

5. Answer: $u^8 + 1/u^8 = 1154$. Hint. The number $u = 1 + \sqrt{2}$ is a root of the quadratic equation $t^2 - 2t - 1$, whose other root can be written as $-1/u$. Thus we find that

$$\begin{aligned} u - 1/u &= 2, \\ u^2 + 1/u^2 &= 6, \\ u^4 + 1/u^4 &= 34, \\ u^8 + 1/u^8 &= 1154. \end{aligned}$$

10. Answer: $(1, 2, 1/2); (1, 1/2, 2);$

$(1/2, 1, 2); (1/2, 2, 1); (2, 1, 1/2); (2, 1, 1/2)$. Hint: If we set

$$x + y + z = a,$$

we get

$$\begin{aligned} P(t) &= (t-x)(t-y)(t-z) \\ &= t^3 - at^2 + at - 1 \\ &= (t-1)(t^2 + t + 1 - at). \end{aligned}$$

So, one of the variables is equal to 1. Now it is possible to solve the system by direct calculation.

13. Answer: $x_1 = x_2 = \dots = x_n = 1$. Hint: Set

$$\begin{aligned} P(t) &= t^n + a_1 t^{n-1} + \dots + a_{n-1} t + a_n \\ &= (t-x_1)(t-x_2) \dots (t-x_n); \end{aligned}$$

then

$$\begin{aligned} 0 &= P(x_1) + P(x_2) + \dots + P(x_n) \\ &= n + na_1 + \dots + na_{n-1} + na_n = nP(1), \end{aligned}$$

and thus, one of the numbers (for example, x_1) is equal to 1. Now we obtain similar systems for x_2, \dots, x_n , and so on.

Exercises.

1. Hint:

$$\begin{aligned} \phi^2 + \phi - 1 &= 0, \\ \phi^4 &= (1-\phi)^2 = 1 - 2\phi + (1-\phi) = 2 - 3\phi, \\ \phi^8 &= 4 - 12\phi + 9\phi^2 = 13 - 21\phi. \end{aligned}$$

2. Answer: 1 cm, 8 cm, 15 cm. Hint: If $x, y,$ and z are the three different lengths of the edges of the parallelepiped, then

$$\begin{aligned} 4(x+y+z) &= 96, \\ 2(xy+yz+zx) &= 286, \\ xyz &= 120. \end{aligned}$$

That is, these are the roots of the equation

$$t^3 - 24t^2 + 143t - 120 = 0.$$

By inspection, 1 is a root, and the other roots can be obtained using standard methods.

3. Answer: $(1, 1, -1); (1, -1, 1); (-1, 1, 1)$. Hint: The first and the second equations, coupled with Vieta's formulas, imply that x, y, z are the roots of the equation

$$t^3 - t^2 - t + r = 0$$

(since

$$\begin{aligned} xy + yz + zx \\ = \frac{(x+y+z)^2 - x^2 - y^2 - z^2}{2} = -1. \end{aligned}$$

Thus, as in problems 3 and 4 we get

$$t^5 = (3-r)t^2 - (2-r)t - 2r$$

for $t = x, y, z$. Adding these relations and using the third equation of the original system, we find that $r = 1$. That is, $x, y,$ and z are the roots of the polynomial

$$t^3 - t^2 - t + 1 = (t-1)^2(t+1).$$

4. Answer:

$$\begin{aligned} 5(x-y)(y-z)(z-x) \\ \times (x^2 + y^2 + z^2 - xy - yz - zx). \end{aligned}$$

Hint: Consider a polynomial with the roots

$$\begin{aligned} u &= x - y, \\ v &= y - z, \\ w &= z - x, \end{aligned}$$

and proceed as in problem 8, taking into consideration that $u + v + w = 0$.

5. Hint: If

$$\begin{aligned} P(t) &= (t-x)(t-y)(t-z) \\ &= t^3 + pt^2 + qt + r, \end{aligned}$$

then

$$-r > 1, -p < q/(-r).$$

Taking $t = 1$, we get

$$\begin{aligned} P(1) &= 1 + p + q + r > 1 + p + pr + r \\ &= (1+p)(1+r) > 0. \end{aligned}$$

That is, $(1-x)(1-y)(1-z) > 0$.

Kaleidoscope

1. A vapor layer forms around the drop on the red-hot plate, tossing the drop upward.

2. When the temperature is rising.

3. At the time when air temperature is lowest (usually around 5 A.M.).

4. Evaporating perspiration effectively cools the body in a desert, but humid air hinders evaporation, which means that the body can easily overheat.

5. The temperature is lower near

the snowdrifts, so the relative humidity of air is higher there. As a result, water evaporation proceeds at a low rate, and even condensation is possible.

6. The pressure of saturated vapor in the open air is much lower than that in the room, because the air temperature in the room is higher. When the window is open, vapor rapidly leaves the room, and therefore the linen will dry quickly.

7. No, it can't, because instead of rarefied air there will be vapor at a pressure equal to atmospheric pressure.

8. By compression, cooling, or both.

9. It is possible for a saturated vapor over a liquid.

10. Yes, they will. The level will rise in the narrow vessel. Vapor drainage from the wide vessel will be stopped, so the vapor in it will be saturated and its pressure will exceed the pressure in the narrow vessel.

11. No, it will not. The vapor will condense during compression and its pressure will not change.

12. Shaking increases the surface of evaporation, which results in higher vapor pressure.

13. The absolute humidity is higher over the river than over the soil.

14. The vapor, which is not saturated for a small drop, will be supersaturated for larger drops. Molecule B (figure 16), which enters the liquid when its surface is flat, will remain in the vapor phase in the case of a curved surface.

Microexperiment

The lid doesn't jump on the kettle that contains less water and where vapor is drained via the spout. The other kettle is filled with a larger amount of water, so vapor collects just below the lid and periodically lifts the lid to escape.

I (mA)	50	70	90	110	140	180	230	290	350
Δx (mm)	1	2	3	4	7	11	16	28	41

Figure 16

Fire and ice: The 1998 International Physics Olympiad

by Dwight E. Neuenschwander

LAST JULY 2–10, 266 HIGHLY motivated students from 56 countries met in Reykjavík, Iceland, for the 29th International Physics Olympiad (IPO). Reykjavík means “smoky waters,” so named because of its numerous hot springs. The air is clean and invigorating in its summer coolness. In summer the Sun dips only slightly under the horizon of Reykjavík harbor after midnight, preserving bright twilight until it emerges over the summit of Mt. Esja before 4 A.M. The geologic creation of Iceland continues in the work of over 200 volcanoes and the Mid-Atlantic Ridge, which passes through the island. Iceland is home to Vatnajökull, the largest glacier in Europe.

The IPO opening ceremonies were held July 3 at the University of Iceland. Folk music was provided by the Hamrahlíð Choir, three dozen young people dressed in traditional Icelandic costume. In Icelandic, they sang

*Come and be joyful
I will dance merrily with my
sweetheart.
May God let us drink from the
goblet of joy.*

“Who can worry about the future with such wonderful people around?” asked the master of ceremonies, Guðrún Pétursdóttir.

The five U.S. Physics Team members in Reykjavík were Elizabeth Scott of Houston, Tex.; Lisa Carlivati

of Reston, Va.; Andrew Lin of Wallingford, Conn.; Michael Lipatov of New York, N.Y.; and Peter Onyisi of Arlington, Va. Team coaches Dwight E. Neuenschwander of Southern Nazarene University in Bethany, Oklahoma, and Mary Mogge of California Polytechnic University in Pomona, California, accompanied the team.

The participants enjoyed Icelandic hospitality as all students and coaches were invited into the homes of local families one evening during the week. A nation’s greatest resource is its people, and Ice-

land is richly blessed despite its small numbers.

The exam

On July 4 the students took the five-hour theoretical portion of the 1998 Physics Olympiad. In Problem 1 they explored the mechanics of a hexagonal prism rolling down an inclined plane. In Problem 2 the pressure beneath an ice cap was determined, and the students predicted the slumping of the surface that results after a conical intrusion of lava melts a cavity beneath the ice. A presentation later in the week



Members of the U.S. Physics Team pose in front of the White House during their visit to Washington, D.C.

Photos courtesy of AAPT

by Magnús Tumi Guðmundsson of the University of Iceland Geophysics Department, describing the volcanic eruption beneath the Vatnajökull Glacier in 1996, revealed how realistic this simple geophysics model can be! For Problem 3 the students used 1994 astrophysical data reporting an apparent superluminal motion of a jet of matter in a galactic radio source. After leading the students into implications of the paradox, the problem statement suggested its resolution by having the students recalibrate the distance to the source using the relativistic Doppler shift.

On July 5, between the Theoretical and Practical Exams, the students enjoyed an excursion. Michael Lipatov was moved by the landscape:

We visited the place where a thousand years ago the first Althingi convened in the hills of Iceland. The waterfalls, the moss-covered cliffs, the incredible history of the place made me feel like never before. The land of the Vikings, their language, their descendants, their history were all around me. It is a fierce land, for people of courage.

In Problem 1 of the experimental exam, the students investigated the attenuation of a magnetic field by various thicknesses of aluminum foil, including the frequency dependence of the attenuation coefficient. Problem 2 asked the students to measure the self-inductance of two coils, then link them like a transformer to determine mutual inductance and the magnetic susceptibility of the core material.

Team USA emerged from the scoring with Honorable Mentions for Lisa Carlivati and Michael Lipatov, a bronze medal for Peter Onyisi, and a silver medal for Andrew Lin. We are very proud of all 25 members of the 1998 U.S. Physics Team and their five representatives. Their places on the team were honorably earned from 1,100 teacher-nominated students from across the United States, and the five represented their country admirably.



U.S. Physics Team representatives in Reykjavik. From left to right: Elizabeth Scott, coach Dwight E. Neuenschwander, Lisa Carlivati, Andrew Lin, Michael Lipatov, coach Mary Mogge, and Peter Onyisi.

In the competition there were 11 gold and 15 silver medals presented, down from recent years. Five gold medals went to China, and three golds and two silvers went to Russia. Iran won one gold, three silvers, and a bronze; Vietnam took one gold and four bronzes; Hungary earned five bronze medals; and Germany bagged four bronzes. India team delivered an impressive performance in its first IPO, with one silver and one bronze.

Lisa Carlivati, in an e-mail message to the other 20 members of Team USA after the competition, reflected on her experience:

We had a wonderful time in Iceland. . . . I want to take this chance to thank everybody again for all your help throughout this experience. I never would have done half as well if I had never met you guys. You are the best. Iceland was great. We walked on a glacier, we saw the Atlantic from the other end, we met all sorts of people. . . . It was a lot of fun.

Amazing grace

In the closing ceremony on July 9, Þórunn Ragnarsdóttir of Íslandbanki, a sponsor of IPO '98, reflected on the reasons for supporting a Physics Olympiad: It forms "the best way to

open our dreams to tomorrow. . . . Young people carry the future." The 1998 IPO General Manager, Viðar Ágústsson, noted that "Life is not only a competition—it's living and enjoying [thunderous applause]. Your knowledge can never be taken away. The memories you gathered here will form a lasting treasure."

The immeasurable worth of this treasure was revealed at the final banquet, held in the village of Hveragerði, located one hour east of Reykjavik. After dinner the stage was opened to any student wishing to perform. Their abilities beyond physics were amazing. For example, Saikal Guha of India performed with incredible skill on the violin the difficult raga "Mishra Bhairarn," which evokes morning in India.

This was also a moment for miracles. Stepping to the stage, Yuan Liu from the People's Republic of China announced, "This is a song of China, called 'Good Wish.'" As she was joined by her teammates and by the team from Taiwan, she said, "We are all Chinese here." Students from Yugoslavia performed arm-in-arm with students from Croatia. A group of 20 students from countries of the former Soviet Union (including our Michael, who speaks fluent Russian) performed a

Russian song together. The Romanians led an enthusiastic sing-along rendition of "We Are the World" that involved the entire audience.

Toward the end of the evening, the American students organized an ensemble to sing three verses of the hymn "Amazing Grace." Michael:

"Amazing Grace" was sung by teams of the USA, Sweden, Portugal, New Zealand, Belgium, and many others off the stage. I felt like it was the finest moment of my life. It certainly concluded

one of the most amazing adventures that has happened to me.

Following the banquet here in the land of fire and ice, we boarded the bus at 1:00 A.M., under a sky still bright with the midnight Sun. But the brightest light of all shines in the eyes—and the futures—of these 266 Olympiad competitors and the thousands of peers they represent. They are the world. May they always be touched by an amazing grace!

Takk fyrir, og vertu sæll! (Farewell, till we meet again!) 

Dwight E. Neuenschwander is the academic director of the U.S. Physics Team and the director of the Society of Physics Students at the American Institute of Physics in College Park, Maryland, and a professor in the Department of Physics at Southern Nazarene University in Bethany, Oklahoma.

Thanks to Team USA's training camp coaches: Mary Mogge, California Polytechnic University; Leaf Turner, Los Alamos National Laboratory; Jennifer Catelli and April Hodari, University of Maryland-College Park; Kate Kevern, Arizona State University; Chris Norris (1995 U.S. Physics Team member), University of California-Berkeley.

Bulletin Board

IMO results

An American team of six high school students placed third out of 76 countries at the 39th International Mathematical Olympiad (IMO), held in Taipei, Taiwan, July 10–21, 1998. Out of a possible 252 points, the American team scored 186. Iran took first place with 211 points, and Bulgaria secured second place with 195 points. The remaining top nine teams were, respectively, Hungary (186), Taiwan (184), Russia (175), India (174), Ukraine (166), Vietnam (158), Yugoslavia (156), Romania (155), and Korea (154).

The American team members were Reid Barton (Arlington, Massachusetts)—gold medalist, Gabriel Carroll (Oakland, California)—gold medalist, Sasha Schwartz (Radnor, Pennsylvania)—gold medalist, Kevin Lacker (Cincinnati, Ohio)—silver medalist, Paul Valiant (Milton, Massachusetts)—silver medalist, and Melanie Wood (Indianapolis, Indiana)—silver medalist.

Titu Andreescu of the Illinois Math and Science Academy was the team's Head Coach and Leader. "We had a very young and ambitious team this year Our team success-

fully defended its position among the IMO powerhouses. Competing against 413 students from around the world, all USA team members achieved gold or silver medals," Andreescu said. The team was also accompanied by Elgin Johnson of Iowa State University and Walter E. Mineka of the University of Nebraska-Lincoln.

Team USA was chosen from the top performers at the USA Mathematical Olympiad, held this past April. The selected team members then participated in a summer program to prepare for the IMO. Said Andreescu, "We conducted an intensive four-week training program preceding the competition and our hard work paid off one more time." The University of Nebraska-Lincoln hosted this year's Mathematical Olympiad Summer Program.

Here's a problem from this year's IMO: "In a competition, there are a contestants and b judges, where b is an odd integer greater than or equal to 3. Each judge rates each contestant as either "pass" or "fail." Suppose k is a number such that, for any two judges, their ratings coincide for at most k contestants. Prove that k divided by a is greater than or equal to $(b - 1)$ divided by $2b$."

Cyber Teaser

The September/October Cyber-Teaser (brainteaser B242 in this issue) lit a fuse for some of you. Judging from the number of correct entries, most of you puzzle-solvers have no problem telling time with pieces of fuse. Here are the first 10 people who submitted a correct answer electronically:

Bruno Konder (Rio de Janeiro, Brazil)
Leo Borovski (Brooklyn, New York)
Jim Nastos (Waterloo, Ontario)
Karl Chen (San Jose, California)
John Beam (Bellaire, Texas)
Jack Merrin (Las Vegas, Nevada)
Worawat Meevasana (Santa Barbara, California)
H. Scott Wiley (Weslaco, Texas)
Nick Baxter (Hillsborough, California)
Liam Hardy (Union City, California)

Each winner will receive a free copy of the September/October issue and a *Quantum* button. Everyone who submitted a correct answer in the allotted time was eligible to win a copy of *Quantum Quandaries*, a collection of the first 100 *Quantum* brainteasers.

Hankering for a prize of your own? Then go to www.nsta.org/quantum and click on the Contest button. 

Across

- 1 10¹²: pref.
- 5 Rap gently
- 9 Ran away
- 13 Bird wing part
- 15 Chemical compound
- 16 Pro ____
- 17 Lipid
- 18 Greek portico
- 19 Pale
- 20 Common circuit elements
- 22 Employs
- 23 Algerian seaport
- 24 Ursa ____ (lesser bear)
- 26 H₃As
- 30 Hyperbolic function
- 31 Scorch
- 32 One tenth: pref.
- 35 Halley's ____
- 39 Habituate
- 41 Actor's signal
- 42 Burning
- 43 Type of cell or wind
- 44 Biochemists Carl and Gerty ____
- 46 Oklahoma city
- 47 Type of bag
- 49 Geometric ____
- 51 Unit of viscosity
- 53 Look searchingly
- 55 Tramp
- 56 Temperature scale
- 62 Surgeon ____ Wangensteen (1898-1981)
- 63 Shakespearean king
- 64 Volley
- 65 Arizona city
- 66 Roughly (2 wds.)
- 67 Band instruments
- 68 Russian city
- 69 Christmas carol
- 70 Focusing device

1	2	3	4		5	6	7	8		9	10	11	12	
13				14		15				16				
17						18				19				
20					21					22				
				23				24	25					
26	27	28	29					30						
31					32	33	34			35		36	37	38
39				40		41				42				
43						44			45		46			
				47		48			49	50				
		51	52					53	54					
55						56	57				58	59	60	61
62						63				64				
65						66				67				
68						69					70			

- 4 Inter ____ (among other things)
- 5 Seed coat
- 6 Astronomer ____ Pannekoek (1873-1960)
- 7 Secure a ship
- 8 Ionized gas
- 9 Type of diffraction
- 10 Cowboy's rope
- 11 Former hypothetical medium of space
- 12 Units of time
- 14 Cornice support
- 21 Made mad
- 25 Ancient Peru Native
- 26 Ad phrase
- 27 Gambling town
- 28 Bible king
- 29 Like some numbers
- 30 Level
- 33 60,622 (in base 16)
- 34 Cupric oxide
- 36 Skirt type
- 37 Great lake
- 38 Koppel and Danson
- 40 God of love
- 45 Words of understanding
- 48 Cookware coating
- 50 1973 Chem. Nobelist ____ Otto Fischer
- 51 Energy per unit time
- 52 Fat
- 53 ____ shift
- 54 Actor ____ Flynn
- 55 Genus of primates
- 57 Of aircraft
- 58 Transport
- 59 European river
- 60 Physiol. ____ Pavlov
- 61 Throw

SOLUTION IN THE NEXT ISSUE

SOLUTION TO THE JULY/AUGUST PUZZLE

G	R	I	E	F		C	O	L	T	S		A	R	E	A		N	A	M					
N	A	N	N	A		A	R	A	I	L		C	I	R	C		I	N	C	H				
A	T	T	A	R		H	A	R	T	E		T	A	T	I		E	N	C	E				
T	H	O	M	A	S	A	L	V	A	E	D	I	S	O	N		L	I	C	E				
					E	D	E	N		A	N	T	O	N		R	U	S	S	E	L	L		
S	C	A	L	A	R		A	L	I		N	I	L		S	I	B							
A	R	E		Y	V	E	S		A	B	O	D	E	S		S	O	N	I	C				
T	E	R	A		E	G	A	S		U	R	E	T	I	C		H	A	S	H				
E	N	O	L	S		G	R	E	A	T		H	E	R		R	O	T	A					
					A	N	S		A	L	E	C		A	N	A		C	I	S				
E	R	N	E	S	T	O	R	L	A	N	D	O	L	A	W	R	E	N	C	E				
L	I	E			E	R	E		D	A	L	Y			L	A	C							
O	V	U	M		E	E	N		N	I	E	C	E		D	O	W	N	S					
P	E	R	I		P	L	A	C	E	D		R	A	Y	S		L	I	O	H				
E	N	O	C	H		S	T	A	R	T	S		R	E	E	F		N	T	A				
					H	A	S		O	R	B		I	V	E		L	E	A	K	E	Y		
G	E	N	E	R	A	L		L	I	S	L	E		A	M	Y	L							
A	N	A	L		B	E	N	J	A	M	I	N	F	R	A	N	K	L	I	N				
T	A	T	S		R	I	A	U		I	C	I	A	N		M	A	I	N	E				
E	C	T	O		E	T	H	N		T	O	N	N	E		A	L	G	E	D				
					T	A	N		S	H	A	G		E	N	G	E	L		N	I	N	E	S

Down

- 1 Magnesium silicate
- 2 Charles lamb
- 3 Wildcats' coach Adolph ____ (1930-1972)



The danger of Italian restaurants

by David Arns

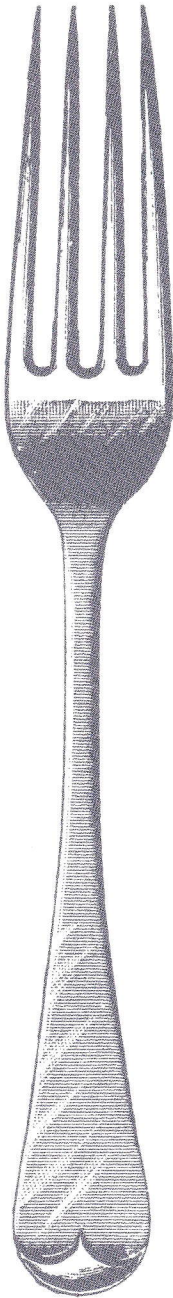

One bright afternoon in the spring of the year,
I took out my family to eat;
With such an enormous selection of spots,
Choosing was not a small feat.

At last we decided: Italian it was,
And the restaurant had opened just recently;
We decided to go in and give it a shot,
And see if they fixed their food decently.

Once seated and reading the menu, I froze:
"Surely," I thought, "This can't be!"
I looked around, wild-eyed, at customers' plates,
Resisting a strong urge to flee.

Two items I'd seen on the menu, I knew,
If combined, would be terribly deadly.
I desperately tried to settle my breathing,
And force my wild heart to beat steadily.

The danger, you see, is most serious indeed,
For the eater and others as well:
Enormous explosions, with high radiation,
Could a knowledge of science foretell.

Explosions so big they could flatten a town—
Reduce it to smoldering crater—
Its molten-glass sides just a hint of the heat
That won't cool until days or weeks later.

"Don't these people know physics?" I thought in my grief,
While pond'ring the coming destruction—
The cooks just plowed on and obviously worked,
Maintaining their rate of production—

"These people can't see that the energy flash
Will be a deathblow to the nation!"
For, of course, mixing pasta and *antipasta*
Would result in complete annihilation!



David Arns is a graphics software documentation engineer for Hewlett-Packard in Fort Collins, Colorado, and also operates a small business designing and creating web sites. In his spare time he dabbles in poetry on scientific themes.

SPRINGER FOR MATHEMATICS

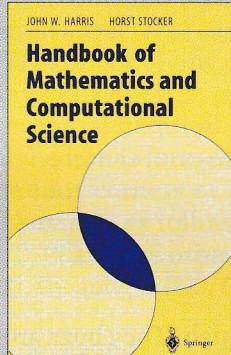

JOHN W. HARRIS, Yale University, CT and HORST STOCKER, Johann Wolfgang Goethe University, Germany (Eds.)

HANDBOOK OF MATHEMATICS AND COMPUTATIONAL SCIENCE

A reference handbook for modern mathematics, *The Handbook of Mathematics and Computational Science* is filled with formulas, equations, tables, and explanations. This fully up-to-date handbook contains new and expanded chapters on Graphs and Algebras, Probability Theory, Mathematical Statistics, Fuzzy Logic, Neural Networks, and the use of Computers. An excellent resource for students and mathematicians alike.

Contents: Numerical Computation (Arithmetics and Numerics) • Equations and Inequalities (Algebra) • Geometry and Trigonometry in the Plane • Solid Geometry • Functions • Vector Analysis • Coordinate Systems • Analytic Geometry • Matrices, Determinants, and Systems of Linear Equations • Boolean Algebra - Application in Switching Algebra • Graphs and Algorithms • Differential Calculus • Differential Geometry • Infinite Series • Integral Calculus • Vector Analysis • Complex Variables and Functions • Differential Equations • Fourier Transformation • Laplace and Z Transformations • Probability Theory and Mathematical Statistics • Fuzzy Logic • Neural Networks • Computers • Tables of Integrals • Index

1998/1056 PP./HARDCOVER/\$29.95/ISBN 0-387-94746-9

WATERLOO MAPLE INCORPORATED, Waterloo, ON, Canada

MAPLE V® STUDENT VERSION: RELEASE 5

(Mac and Windows on CD-Rom)

The Maple V Student Version: Release 5, Mac and Windows on CD ROM, provides the science student with the powerful symbolic and numeric computational capabilities of the Maple V computer algebra system. An easy-to-implement programming language and comprehensive library of built-in mathematical functions make solving problems from algebra to differential equations fast and reliable. Maple's open architecture gives one freedom to develop a personalized library of functions or to customize the system for almost any application. Maple's two and three dimensional graphics puts the power of scientific visualization on your desktop. Maple V features the most advanced graphical interface in a student version. In addition to being able to quickly solve math problems, you can create exciting electronic or printed technical documents. Word processing features such as collapsible sections, document styles, and complete font control provide maximum flexibility for creating professional looking technical documents. This package includes the *Maple V Learning Guide*.

1998/\$99.00/ISBN 0-387-14240-1

A. ENGEL, Johann Wolfgang Goethe Universität, Germany PROBLEM-SOLVING STRATEGIES

Problem Solving Strategies is a unique collection of competition problems from over twenty major national and international mathematical competitions for high school students. The discussion of problem solving strategies is extensive. It will appeal to high school teachers conducting a mathematics club who need a range of simple to complex problems and to those instructors wishing to pose a "problem of the week," "problem of the month," and "research problem of the year" to their students, thus bringing a creative atmosphere into their classrooms with continuous discussions of mathematical problems. This volume is a must-have for instructors wishing to enrich their teaching with some interesting non-routine problems and for individuals who are just interested in solving difficult and challenging problems.

1997/416 PP., 223 ILLUS./SOFTCOVER/\$39.95
ISBN 0-387-98219-1
PROBLEM BOOKS IN MATHEMATICS

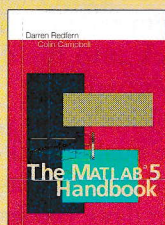

DARREN REDFERN, Practical Approach Corporation, Waterloo, Canada and COLIN CAMPBELL, University of Waterloo, Canada

THE MATLAB® 5 HANDBOOK

The Matlab Handbook is an easily accessible reference tool of the first resource

for the numerical computation system Matlab. It provides the reader with a definitive listing of each Matlab element, in both the standard library and the applications toolboxes, with a brief, yet precise description of its working; a well-structured organization of the available Matlab elements into logical subject areas where each relevant element is described in terms of its connection with the subject area as a whole; a practical introduction to each subject area and to Matlab programming as a whole; and cross-references to the most popular Matlab manuals and application texts. Everyone who uses Matlab in more than the most cursory fashion will find this book a helpful tool, not only because of its structure, but because it combines elements previously unavailable in any other book or in the on-line help files for Matlab. It is fully up to date for Matlab 5.

1998/522 PP./SOFTCOVER/\$34.95/ISBN 0-387-94200-9

R. LAUBENBACHER and D. PENGELLEY, both of New Mexico State University

MATHEMATICAL EXPEDITIONS Chronicles by the Explorers

Certainly almost every mathematical idea is built upon a succession of preceding ideas. And as one goes back along this chain, the motivation for a problem which started the journey becomes ever clearer, with several works in the chain often standing out as milestones on the road toward our present knowledge. By working through some of these original sources which discuss and solve, or attempt to solve, antecedent problems, this book helps to discover the roots of modern problems, ideas, and concepts, even whole subjects. Students will also see the obstacles that earlier thinkers had to clear in order to move ahead. Readers will thereby gain insights into current problems and how to approach them.

1998/APP. 376 PP., 93 ILLUS./HARDCOVER/\$59.95
ISBN 0-387-98434-8
ALSO AVAILABLE IN SOFTCOVER \$32.00/ISBN 0-387-98433-X

O.A. IVANOV, St. Petersburg State University, Russia, and R.G. BURNS, York University, Canada

EASY AS PI?

An Introduction to Higher Mathematics

This book aims at introducing the reader with some high school mathematics to both the higher and the more fundamental developments of the basic themes of elementary mathematics. Most chapters begin with a series of elementary problems, behind whose diverting formulation more advanced mathematical ideas lie hidden. These are then made explicit and further developments of them explored, thereby deepening and broadening the reader's understanding of mathematics enabling him or her to see mathematics as a hologram. The book arose from a course for potential high school teachers of mathematics taught for several years at St. Petersburg University, and nearly every chapter ends with an interesting commentary on the relevance of its subject matter to the actual classroom setting. However, it can be recommended to a much wider readership; even the professional mathematician will derive much pleasurable instruction from reading it.

1998/APP. 240 PP., 60 ILLUS./SOFTCOVER/\$29.95
ISBN 0-387-98521-2

EDWARD LOZANSKY, National Science Teachers' Association, Washington, DC and CECIL ROUSSEAU, University of Memphis, TN

WINNING SOLUTIONS

1996/256 PP./SOFTCOVER/\$34.95/ISBN 0-387-94743-4
PROBLEM BOOKS IN MATHEMATICS

Order Today!

CALL: 1-800-SPRINGER or Fax: (201)-348-4505

WRITE: Springer-Verlag New York, Inc., Dept. H239,
PO Box 2485, Secaucus, NJ 07096-2485

VISIT: Your local technical bookstore

E-MAIL: orders@springer-ny.com

INSTRUCTORS: Call or write for info on textbook exam copies.

YOUR 30-DAY RETURN PRIVILEGE IS ALWAYS GUARANTEED!



Springer

<http://www.springer-ny.com>

Fly Zapper

by Dr. Mu

WELCOME BACK TO COWCULATIONS, THE column devoted to problems best solved with a computer algorithm. Black flies are the "swarm" enemy of all cows. These pesky critters attack us unmercifully and can really get under our skin. Our ancestors, who must have suffered from the same problem, evolved a flexible defensive weapon and, so we wouldn't lose it, attached it to our rear.

Farmer Paul keeps the flies inside the barn under control by taking advantage of their stupidity. He built a dimly lit vestibule entrance of two cow lengths where we enter the barn. Near the middle of this space he placed a blanket low enough that we have to duck our heads when we enter. The flies on our head, neck, and

back are swept off as we pass through. They buzz around in the dimness until they spot a bright slit overhead, fly up through it, and find themselves in a closed empty room full of windows. They don't have the brains to go back into the darkness to save themselves, and they eventually fly themselves to death against a window looking for an escape. Farmer Paul sweeps them up by the bushel basketful.

But in the pastures, where we love to spend our summer days, the fly problem has gotten out of control. In an effort to rid this space of the flies for good, Farmer Paul has built his very own Fly Zapper. It's an electronic jolt generator mounted on an ultralight plane, which I fly over the fields. When the zap button is pushed, a polyhedron



Art by Mark Brenneman

shaped death charge rains down to earth. Any fly near a lattice point inside this polyhedron is toast. (Lattice points are points $\{x, y, z\}$ with integer values.)

Let's do the math. Farmer Paul farms 173 acres of land laid out in a square, 12,000 yards to a side. He places an attracter at each of the four corners of the farm. The Fly Zapper, flying over the land, releases its charge at the zap location $\{z, a, p\}$, to the nearest yard. (For this discussion, the unit of length will always be the yard.) A polyhedron is formed by joining the zap point to each of the four corners of the farm. This is illustrated in *Mathematica* as follows. Place one corner of the farm at $\{0, 0, 0\}$ and the other corners at $\{0, 12000, 0\}$; $\{12000, 12000, 0\}$; and $\{12000, 0, 0\}$."

```
side = 12000; (*length of one side of the
  farm in yards*)
zap = {6000, 9000, 10000}; (*zap point
  above farm*)
polyhedron = Line[{{0, 0, 0}, {0, side, 0},
  {side, side, 0}, {side, 0, 0}, {0, 0, 0},
  zap, {0, side, 0}, {side, side, 0}, zap,
  {side, 0, 0}}];
Show[Graphics3D[polyhedron], Boxed ->
  False]
```

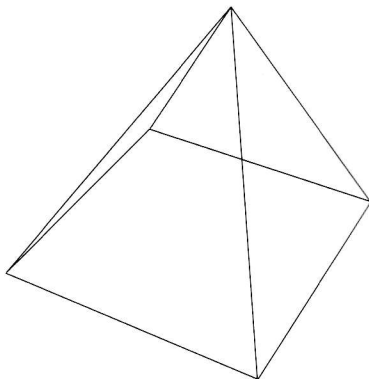

Below is the set of 1,665 zapped flies within a polyhedron with base size of 20 and zap point $\{12, 12, 14\}$.

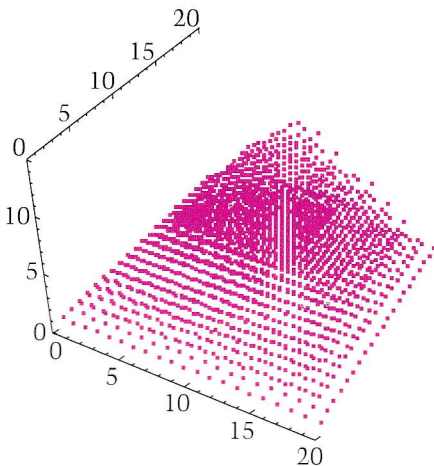

This suggests a problem, which, you guessed it, is your next Challenge Outta Wisconsin.

COW 12

How many flies can be zapped above Farmer Paul's land with a single jolt from a Fly Zapper at the zap point $\{6000, 9000, 10000\}$, assuming the square base has sides of length = 12000. Write a program that will accept any zap point $\{z, a, p\}$ of positive integers and any base of positive integer length and have it cowculate the number of lattice points inside the polyhedron formed by the square base and the zap point. Don't include any flies on the surface of the polyhedron.

*Black flies are swarming in the sky.
Load up your charge and let her fly.
Find a point to zap them all.
And count the bodies as they fall.
When you're done, come back to earth.
You've zapped this COW for all it's worth.*
—Dr. Mu

Solution to COW10

In COW10 you were asked to write a program that finds the shortest path around the herd and cowculate its length. Recall our construction of a random herd.

```
cow := {Random[], Random[]}
cows = Table[cow, {40}];
herd = {PointSize[.02], Point/@ cows};
Show[Graphics[herd]];
```

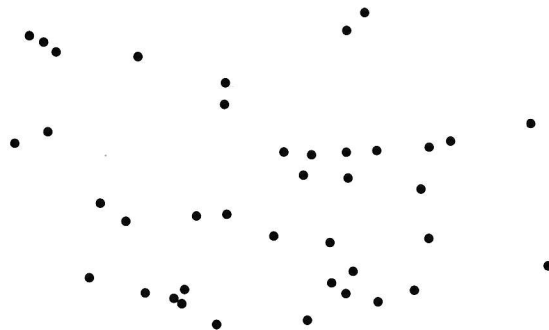

A function to measure the length of a path was provided.

```
pathlength[path_] := (Apply[Plus,
  Map[ $\sqrt{\#.\#}$  &, path - RotateRight[path]])
```

I also constructed a simple closed path around the herd based on the centroid of the cows. The path was ordered based on the polar angle of each cow with the centroid.

```
angle[a_, b_] := Apply[ArcTan, (b - a)]
centroid = Apply[Plus, cows] / Length[cows];
cows = Sort[cows, (angle[centroid, #1]
  <= angle[centroid, #2])&];
route = Line[Join[cows, {First[cows]}]];
Print["Simple closed path length = ",
  pathlength[cows]]
p1 = Show[Graphics[{route, herd}]]
```

Simple closed path length = 6.28958

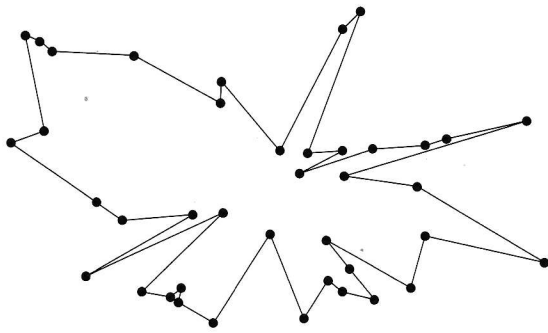

The key to finding the shortest route around the herd is to skip all cows that live at a *right turn* as you travel around the simple closed curve in a counterclockwise direction. Suppose that on the simple closed path you identify three consecutive cows, *u*, *v*, and *w*. It can be shown by elementary vector analysis that cow *v* lives on a right turn if the determinant of

$$\begin{pmatrix} v - u \\ w - v \end{pmatrix}$$

is negative and on a left turn if it is positive. So we use this fact to define a test for a left turn at *v*.

```
leftturn[{u_, v_, w_}] := Det[{v - u,
  w - u}] >= 0
```

The heart of the *Mathematica* solution is to consider all triplets of consecutive cows, delete the ones who live on right turns, and repeat this process until there is no longer any change in the number of cows on the path. We begin by defining a **takeOutRightTurns** function.

```
takeOutRightTurns[cows_] := Select[Partition
  [Join[cows, Take[cows, 2]], 3, 1],
  leftturn[#]&] /. {x_, y_, z_} -> y
```

Now watch what happens when we apply this function to the cows on the original simple closed path.

```
cows = takeOutRightTurns[cows];
route = Line[Join[cows, {First[cows]}]];
Print["Simple closed path length = ",
  pathlength[cows]]
p2 = Show[Graphics[{route, herd}]]
```

Simple closed path length = 3.73923

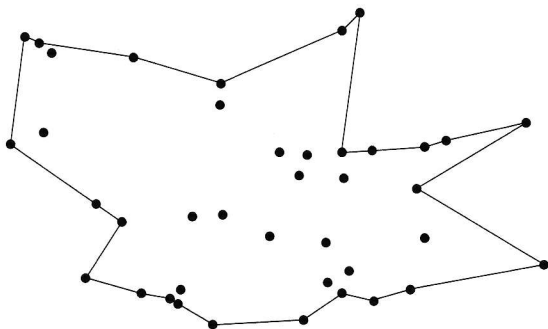

We see that our first iteration has deleted many right turns but has developed some new ones in the process. So we simply **takeOutRightTurns** again.

```
cows = takeOutRightTurns[cows];
route = Line[Join[cows, {First[cows]}]];
Print["Simple closed path length = ",
  pathlength[cows]]
p3 = Show[Graphics[{route, herd}]]
```

Simple closed path length = 3.07379

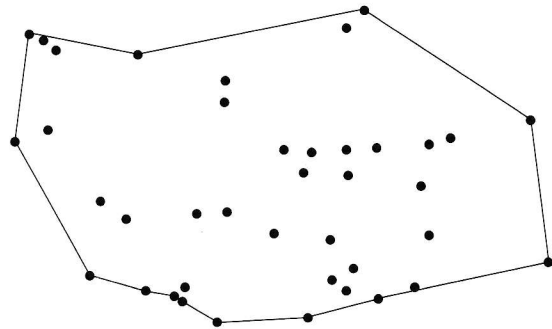

We're not rid of all right turns yet, so we continue.

```
cows = takeOutRightTurns[cows];
route = Line[Join[cows, {First[cows]}]];
Print["Simple closed path length = ",
  pathlength[cows]],
p4 = Show[Graphics[{route, herd}]]
```

Simple closed path length = 3.04932

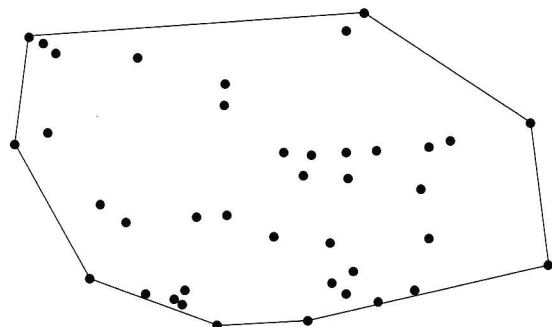

After three iterations, we have a path with only left turns remaining, and this is the shortest path around the herd. Putting the stages all together, we see the evolution of the solution.

```
Show[GraphicsArray[{{p1, p2}, {p3, p4}}];
```

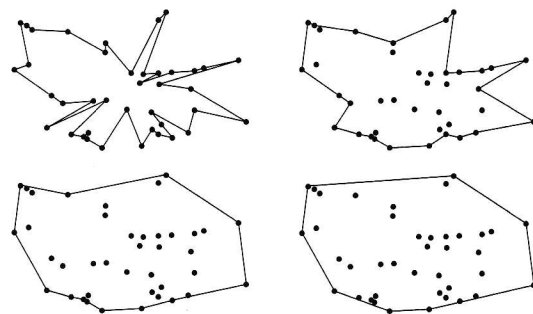

There is a simple way to go directly from the simple closed curve to shortest path by iterating the **takeOutRightTurns** function via *Mathematica* using the **FixedPoint** function. This function applies the **takeOutRightTurns** function to the cows until the length of the path no longer changes.

```
shortestPath =
FixedPoint[takeOutRightTurns, cows,
SameTest -> (Length[#1] == Length[#2]&)];
```

And finally ...

Send in your solutions to COW 12, in any language, to drmu@cs.uwp.edu. Past *Mathematica* solutions are available on the Internet at <http://usaco.uwp.edu/cowculations>.

If you like to zap the competition while programming a computer in C/C++ or Pascal, stop by the USA Computing Olympiad web site at <http://usaco.uwp.edu>. The 1998 USA Team of Matt Craighead, Tom Do, Adrian Sox, and Alex Wissner-Gross has just returned from the 10th International Olympiad in Informatics held in Setúbal, Portugal, September 5–12, 1998. Check out the links to IOI' 98 and see how over 60 teams from around the world fared in this international programming competition for precollege students. It could be the challenge you've been waiting for—if you've got the right stuff. 

Index of Advertisers

American Mathematical Society (65, cover 4), Knowledge Revolution (7), Metrologic Instruments (65), Princeton University Press (45), Springer-Verlag, Inc. (41, 61)

METROLOGIC® EDUCATIONAL LASERS

Helium-Neon Lasers
ranging from .05 to 5.0mW
NOW AVAILABLE IN
GREEN (.05mW only)



Laser Pointer 3mW
Only \$49.95
Optics Kit \$20.00



Various Kits Also Available

- * speed of light
- * build a laser kit
- * laser optics lab
- * physical optics lab
- * power meters

1-800-667-8400

In New Jersey 609-228-8100
90 COLES ROAD
BLACKWOOD, NJ 08012
EDUCATIONAL DISCOUNTS AVAILABLE

Circle No. 3 on Reader Service Card

AMERICAN MATHEMATICAL SOCIETY

What's Happening in the Mathematical Sciences, 1998–1999

Barry Cipra

Praise for volumes 1, 2 and 3 of *What's Happening*

Stylish format ... largely accessible to laymen ... This publication is one of the snappier examples of a growing genre from scientific societies seeking to increase public understanding of their work and its societal value.

—*Science & Government Report*

Another choice of new exciting developments in mathematics. These volumes really deserve a large audience, students as well as researchers will be fascinated by the insights and overviews presented.

—*Zentralblatt für Mathematik*

The topics chosen and the lively writing fill a notorious gap—to make the ideas, concepts and beauty of mathematics more visible for the general public ... well-illustrated ... Congratulations to Barry Cipra.

—*Zentralblatt für Mathematik*

This volume is fourth in the much-acclaimed AMS series *What's Happening in the Mathematical Sciences*. The lively style and in-depth coverage of some of the most important "happenings" in mathematics today make

this publication a delightful and intriguing read accessible to a wide audience. High school students, professors, researchers, engineers, statisticians, computer scientists—anyone with an interest in mathematics—will find captivating material in this book. As the 20th century draws to a close, *What's Happening* presents the state of modern mathematics and its worldwide significance in a timely and enduring fashion.

Featured articles include ...

- "From Wired to Weird", on advances that are encouraging research in quantum computation.
- "A Prime Case of Chaos", on new connections between number theory and theoretical physics.
- "Beetlemania: Chaos in Ecology", on new evidence for chaotic dynamics in an actual population.
- "A Blue-Letter Day for Computer Chess", on the mathematics underlying Deep Blue's victory over Garry Kasparov, and much more!

What's Happening in the Mathematical Sciences, Volume 4; 1998; approximately 120 pages; Softcover; ISBN 0-8218-0766-8; List \$14; Order code HAPPENING/4Q89

All prices subject to change. Charges for delivery are \$3.00 per order. For optional air delivery outside of the continental U. S., please include \$6.50 per item. Payment required. Order from: American Mathematical Society, P. O. Box 5904, Boston, MA 02206-5904, USA. For credit card orders, fax 1-800-455-4006 or call toll free 1-800-321-4AMS (4267) in the U. S. and Canada, 1-401-455-4000 worldwide. Or place your order through the AMS bookstore at www.ams.org/bookstore. Residents of Canada, please include 7% GST.



AMS
AMERICAN MATHEMATICAL SOCIETY

Circle No. 4 on Reader Service Card

NEW FROM THE AMS

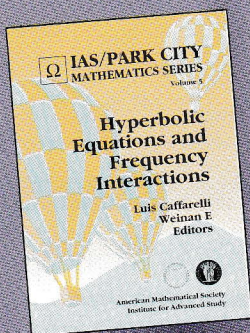

Hyperbolic Equations and Frequency Interactions

Luis Caffarelli and Weinan E. *Courant Institute, New York University, New York*, Editors

The research topic for this IAS/PCMS Summer Session was nonlinear wave phenomena. Mathematicians from the more theoretical areas of PDEs were brought together with those involved in applications. The goal was to share ideas, knowledge, and perspectives.

How waves, or "frequencies", interact in nonlinear phenomena has been a central issue in many of the recent developments in pure and applied analysis.

Included in this volume are write-ups of the "general methods and tools" courses held by Jeff Rauch (on geometric optics) and Ingrid Daubechies (on wavelets).

Also included are specialized articles such as "Nonlinear Schrödinger Equations" by Jean Bourgain, "Waves and Transport" by George Papanicolaou and Leonid Ryzhi, and "Stability and Instability of an Ideal Fluid" by Susan Friedlander.

IAS/Park City Mathematics Series, Volume 5; 1999; 466 pages; Hardcover; ISBN 0-8218-0592-4; List \$69; All AMS members \$55; Order code PCMS/5189

Classical Galois Theory with Examples

Lisl Gaal

This book is strongly recommended to beginning graduate students who already have some background in abstract algebra ... The large number of partially or fully solved examples is its special feature.

—*Mathematical Reviews*

Excellent for undergraduate independent study since it demands reader participation.

—*American Mathematical Monthly*

AMS Chelsea Publishing; 1998; 248 pages; Hardcover; ISBN 0-8218-1375-7; List \$29; All AMS members \$26; Order code CHEL/268.H189

Recommended Text

Partial Differential Equations

P. R. Garabedian

AMS Chelsea Publishing; 1998; 672 pages; Hardcover; ISBN 0-8218-1377-3; List \$45; All AMS members \$41; Order code CHEL/325.H189

Recommended Text

Partial Differential Equations

Lawrence C. Evans, *University of California, Berkeley*

This text gives a comprehensive survey of modern techniques in the theoretical study of partial differential equations (PDEs) with particular emphasis on nonlinear equations. The exposition is divided into three parts: 1) representation formulas for solutions, 2) theory for linear partial differential equations, and 3) theory for nonlinear partial differential equations.

The author summarizes the relevant mathematics required to understand current research in PDEs, especially nonlinear PDEs. While he has reworked and simplified much of the classical theory (particularly the method of characteristics), he primarily emphasizes the modern interplay between functional analytic insights and calculus-type estimates within the context of Sobolev spaces. Treatment of all topics is complete and self-contained. The book's wide scope and clear exposition make it an excellent text for a graduate course in PDEs.

Graduate Studies in Mathematics, Volume 19; 1998; 662 pages; Hardcover; ISBN 0-8218-0772-2; List \$75; All AMS members \$60; Order code GSM/19189

Model Categories

Mark Hovey, *Wesleyan University, Middletown, CT*

Model categories are a tool for inverting certain maps in a category in a controllable manner. As such, they are useful in diverse areas of mathematics. The list of such areas is continually growing.

This book is a comprehensive study of the relationship between a model category and its homotopy category. The author develops the theory of model categories, giving a careful development of the main examples.

The book requires little from the reader beyond standard first-year algebraic topology, some category theory and set theory, making it accessible to graduate students.

Mathematical Surveys and Monographs; 1999; 207 pages; Hardcover; ISBN 0-8218-1359-5; List \$54; Individual member \$32; Order code SURV-HOVEY189

The Book of Involutions

Max-Albert Knus, *Eidgenössische Technische Hochschule, Zürich, Switzerland*, Alexander Merkurjev, *University of California, Los Angeles*, Markus Rost, *Universität at Regensburg, Germany*, and Jean-Pierre Tignol, *Université Catholique de Louvain, Louvain-la-Neuve, Belgium*

This monograph is an exposition of the theory of central simple algebras with involution, in relation to linear algebraic groups. It provides the algebra-theoretic foundations for much of the recent work on linear algebraic groups over arbitrary fields. Involutions are viewed as twisted versions of bilinear forms, leading to new developments in the algebraic theory of quadratic forms. In addition to classical groups, phenomena related to triality are also discussed, as well as groups of type F_4 or G_2 arising from exceptional Jordan or composition algebras. Several results and notions appear here for the first time, notably the discriminant algebra of an algebra with unitary involution and the algebra-theoretic counterpart to linear groups of type D_4 .

Colloquium Publications, Volume 44; 1998; 593 pages; Hardcover; ISBN 0-8218-0904-0; List \$69; All AMS members \$55; Order code COLL/44189

Prospects in Mathematics

Invited Talks on the Occasion of the 250th Anniversary of Princeton University

Hugo Rossi, *Mathematical Sciences Research Institute, Berkeley*, Editor

In celebration of Princeton University's 250th anniversary, the mathematics department held a conference entitled "Prospects in Mathematics". The purpose of the conference was to speculate on future directions of research in mathematics.

The volume contains 11 articles by leading mathematicians, based on talks at the conference. It provides a guide to some of the most significant mathematical work of this decade.

1999; 154 pages; Hardcover; ISBN 0-8218-0975-X; List \$29; All AMS members \$23; Order code PIM-ROSSI189

Mirror Symmetry I

Shing-Tung Yau, *Harvard University, Cambridge, MA*, Editor

This volume is an updated edition of *Essays on Mirror Manifolds*, the first book of papers published after the phenomenon of mirror symmetry was discovered. It continues to be an important book on this spectacular achievement in algebraic geometry and mathematical physics.

AMS/IP Studies in Advanced Mathematics, Volume 9; 1998; 444 pages; Hardcover; ISBN 0-8218-0665-3; List \$49; Individual member \$29; Order code AMSIP/9189

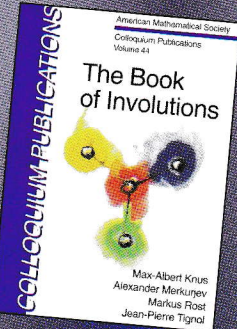
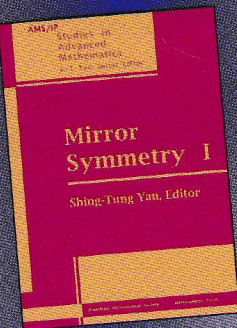
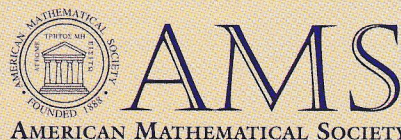

All prices subject to change. Charges for delivery are \$3.00 per order. For optional air delivery outside of the continental U. S., please include \$6.50 per item. Prepayment required. Order from: American Mathematical Society, P. O. Box 5904, Boston, MA 02206-5904, USA. For credit card orders, fax (401) 455-4046 or call toll free 800-321-4AMS (4267) in the U. S. and Canada, (401) 455-4000 worldwide. Or place your order through the AMS bookstore at www.ams.org/bookstore/. Residents of Canada, please include 7% GST.