

LA TIMBER BRIDGE

From Forest to Home

Welcome to Would Works. WW started when a young caseworker in Skid Row heard people there say “**I would work if I could.**” He took action with a simple mission to provide satisfying work to meet immediate financial needs of people experiencing homelessness. Eleven years later, that idea has snowballed into a thriving social enterprise that empowers people who face high employment barriers and are often housing insecure, **build a long-term career pathway in wood-working**, help to break the cycle of system-dependency, and provide a healing creative community.

Our latest evolution is the **Community Builders Program** where we train Artisans in furniture fabrication and community led design while employing them to build **outdoor furniture for supportive housing sites, service providers, and public spaces** throughout Los Angeles. CBP addresses the professional and creative ambitions of our Artisans, while addressing the economic, public health, and functional needs in the broader LA community.



MORE INSIGHT

A New Approach to Nature

Our outdoor furniture pieces have a long life ahead of them, but they also have a rich history.

Each item of furniture is made exclusively from materials rescued from the Angeles National Forest after the Bobcat Fire of 2020. In partnership with Angel City Lumber, we were able to transition fallen wood into functional furniture, designed specifically to serve communal spaces in Los Angeles.

But there is more to us than our positive climate impact. This program will achieve the following outcomes:

- Expand our programming for Artisans who complete our beginner workshop and want to learn more advanced techniques in fabrication and design--thus creating a pathway for stable employment for economically vulnerable individuals annually.
- Furnish safe, comfortable and accessible communal spaces for underserved populations in Los Angeles.
- Empower these communities by way of a peer driven design/build process which trains residents to adapt, create and maintain fixtures in their own collective spaces and neighborhoods.
- Design and market a repeatable line of accessible outdoor furniture, in turn providing Would Works with ongoing commissions and revenue to support our programs.

Every aspect of our program intentionally touches to create the best product as well as the highest impact. **We're a nonprofit with people and the planet in mind.** But no need to sacrifice form or function to support our mission, we promise to deliver the best of both.

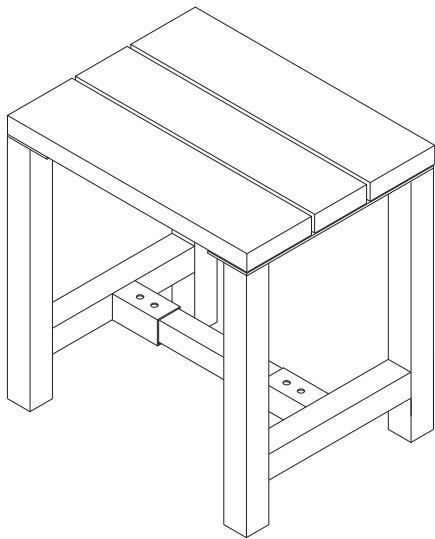

SINGLE NO. 1



Feel the warmth
of old growth
forest wood.

DESCRIPTION

We love choice and SINGLE No. 1 offers just that! Today it functions as a chair. Tomorrow it performs as a side table. Use it as you wish!

Mix and match with SINGLE No. 2!

DIMENSIONS

Seat Height: 19.25"

Back Height: N/A

Width: 20"

Depth: 16.5"

MATERIALS

Powder coated steel tube contrast soft woods rescued from the Angeles National Forest after the Bobcat Fire of 2020, sealed with a hardwax oil, exterior finish.

POWDER COAT COLORS



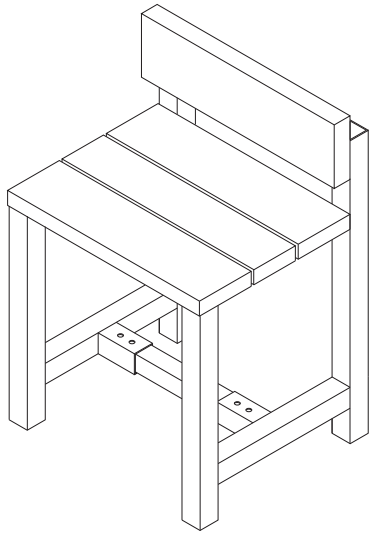

SINGLE NO. 2



Lunch Chair No. 1 (Left)
Single Chair No. 2 (Right)

DESCRIPTION

Take a seat to share a meal or conversation and make connection on Would Works' first chair design.

SINGLE No. 2 is designed for the height of its companion, DINING TABLE No. 1.

DIMENSIONS

Seat Height: 19.25"
Back Height: 25.25"
Width: 20"
Depth: 16.5"

MATERIALS

Powder coated steel tube contrast soft woods rescued from the Angeles National Forest after the Bobcat Fire of 2020, sealed with a hardwax oil, exterior finish.

POWDER COAT COLORS



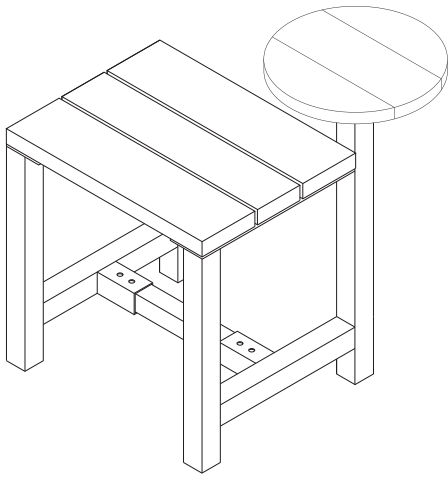

SINGLE NO. 3



A small private island for one's imagination.

DESCRIPTION

SINGLE No. 3 offers residents the perfect place to pause and take a moment to center in an outdoor or inside communal space.

Utilize one on its own or pull one up next to a friend!

DIMENSIONS

Seat Height: 19.25"

Back Height: N/A

Width: 20"

Depth: 16.5"

MATERIALS

Powder coated steel tube contrast soft woods rescued from the Angeles National Forest after the Bobcat Fire of 2020, sealed with a hardwax oil, exterior finish.

POWDER COAT COLORS



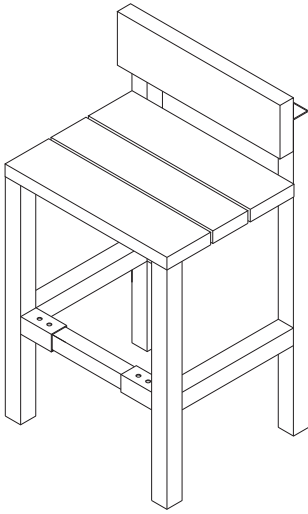

LUNCH CHAIR NO. 1



A perfect pair
to dine al fresco.

DESCRIPTION

Some circumstances call for slightly higher seating and LUNCH CHAIR No. 1 is here to answer that call.

LUNCH CHAIR No. 1 is designed for the height of its companion, LUNCH COUNTER No. 1.

DIMENSIONS

Seat Height: 24"

Back Height: 32.5"

Width: 20"

Depth: 16.5"

MATERIALS

Powder coated steel tube contrast soft woods rescued from the Angeles National Forest after the Bobcat Fire of 2020, sealed with a hardwax oil, exterior finish.

POWDER COAT COLORS



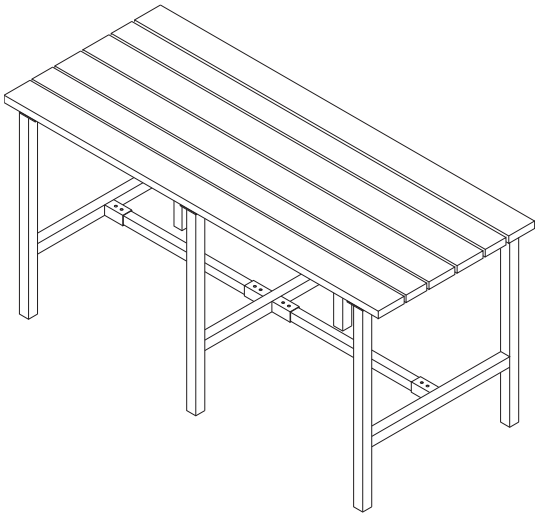

LUNCH COUNTER NO. 1



Make it longer
or shorter based
on the needs of
your space

DESCRIPTION

While its name references a meal, LUNCH COUNTER No. 1 can be used as an activity table as well. TA-DA!

LUNCH COUNTER No. 1 is designed for the height of its companion, LUNCH CHAIR No. 1.

DIMENSIONS

Height: 35.25"

Length: 30"- standard

Width: 30"

MATERIALS

Powder coated steel tube contrast soft woods rescued from the Angeles National Forest after the Bobcat Fire of 2020, sealed with a hardwax oil, exterior finish.

POWDER COAT COLORS



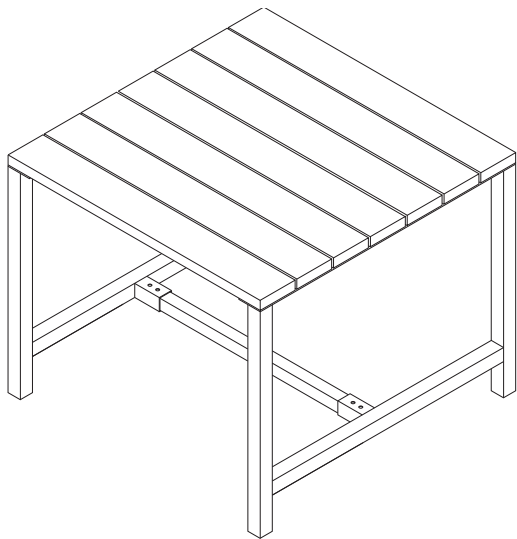

DINING NO. 1



Make it longer
or shorter based
on the needs of
your space

DESCRIPTION

Break bread or host a meeting with 6-8 people comfortably with DINING No. 1.

Create a dining set by combining DINING No. 1 with QUAD No. 1.

DIMENSIONS

Height: 29.75"

Length: 80"- standard

Width: 36"

MATERIALS

Powder coated steel tube contrast soft woods rescued from the Angeles National Forest after the Bobcat Fire of 2020, sealed with a hardwax oil, exterior finish.

POWDER COAT COLORS



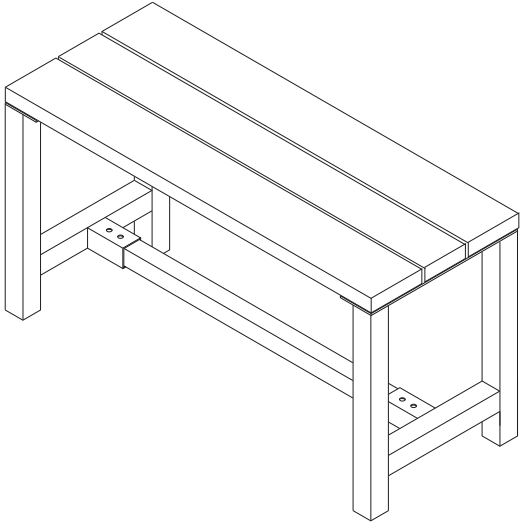

DOUBLE NO. 1



X No. 1 (Front)
Double No. 1 (Back)

DESCRIPTION

DOUBLE No. 1 offers a seat for two or provides coffee table applications for those who gather around it.

Combine with pieces from Would Works' debut collection to make lively configurations in any space!

DIMENSIONS

Seat Height: 19.25"

Back Height: N/A

Width: 40"

Depth: 16.5"

MATERIALS

Powder coated steel tube contrast soft woods rescued from the Angeles National Forest after the Bobcat Fire of 2020, sealed with a hardwax oil, exterior finish.

POWDER COAT COLORS



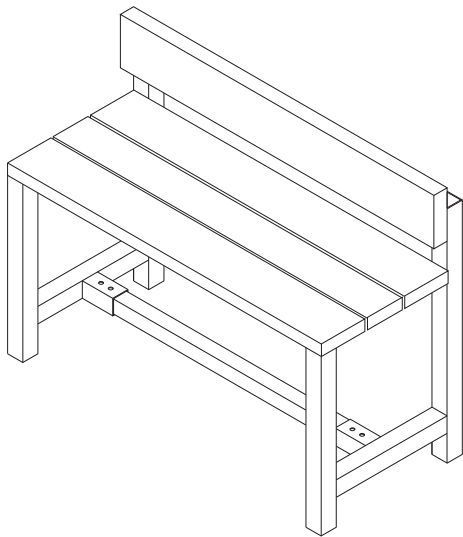

DOUBLE NO. 2



Discover a tree's life through all its knotty imperfections.

DESCRIPTION

Cozy up with another on DOUBLE No. 2 and take a moment to enjoy one another's company.

Combine with pieces from Would Works' debut collection to make lively configurations in any space!

DIMENSIONS

Seat Height: 19.25"

Back Height: 25.25"

Width: 40"

Depth: 16.5"

MATERIALS

Powder coated steel tube contrast soft woods rescued from the Angeles National Forest after the Bobcat Fire of 2020, sealed with a hardwax oil, exterior finish.

POWDER COAT COLORS



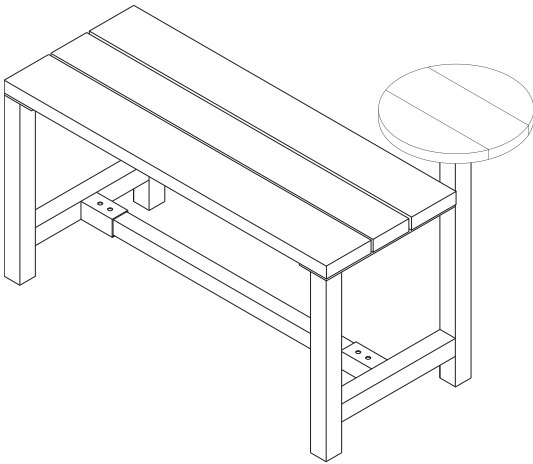

DOUBLE NO. 3



A little extra room
for you and your
belongings

DESCRIPTION

A simple bench that offers connection and conversation or contemplative moments.

An ideal spot to share a coffee with another person or ample room for the user and their possessions.

DIMENSIONS

Seat Height: 19.25"

Back Height: N/A

Width: 40"

Depth: 16.5"

MATERIALS

Powder coated steel tube contrast soft woods rescued from the Angeles National Forest after the Bobcat Fire of 2020, sealed with a hardwax oil, exterior finish.

POWDER COAT COLORS





X NO. 1



DESCRIPTION

Made from 100% wood, X No. 1 may be utilized both indoors and outdoors as a stool or side table.

Mingle X No. 1 with SINGLE No. 1 to play around with circles and squares.

A moment
to contemplate
the beauty of
wood grain.

DIMENSIONS

Height: 18"

Width: 22"

Depth: 22"

MATERIALS

Crafted with soft woods rescued from the Angeles National Forest after the Bobcat Fire of 2020, sealed with an exterior, hardwax oil protective finish.

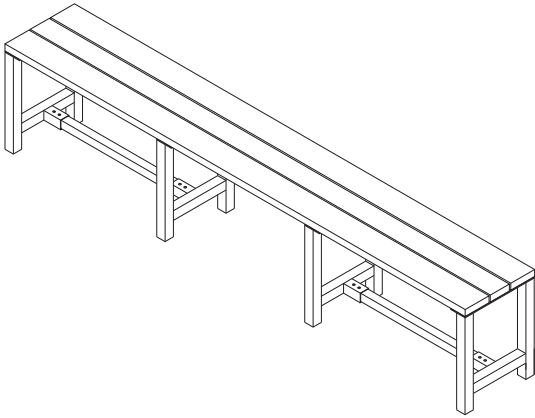

QUAD NO. 1



Custom lengths
available for
an added fee

DESCRIPTION

Invite residents to take a seat on this bench in courtyards, entrance halls, dining rooms or garden spaces.

Create a dining set by combining DINING No. 1 with QUAD No. 1.

DIMENSIONS

Seat Height: 19.25"

Back Height: N/A

Length: 80" standard

Depth: 16.5"

MATERIALS

Powder coated steel tube contrast soft woods rescued from the Angeles National Forest after the Bobcat Fire of 2020, sealed with a hardwax oil, exterior finish.

POWDER COAT COLORS



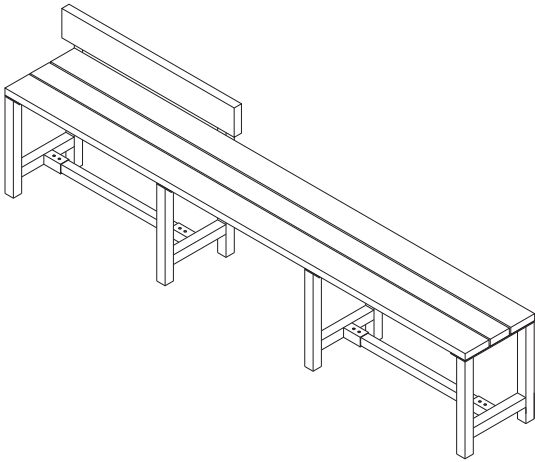

QUAD NO. 2



Share a seat
with not 1 or 2
but up to
3 neighbors!

DESCRIPTION

QUAD No. 2 offers multiple uses with its halfback configuration. Imagine the possibilities!

Beautiful as a standalone piece or mix it with other items from Would Works' debut collection.

DIMENSIONS

Seat Height: 19.25"

Back Height: 25.25"

Width: 80"

Depth: 16.5"

MATERIALS

Powder coated steel tube contrast soft woods rescued from the Angeles National Forest after the Bobcat Fire of 2020, sealed with a hardwax oil, exterior finish.

POWDER COAT COLORS



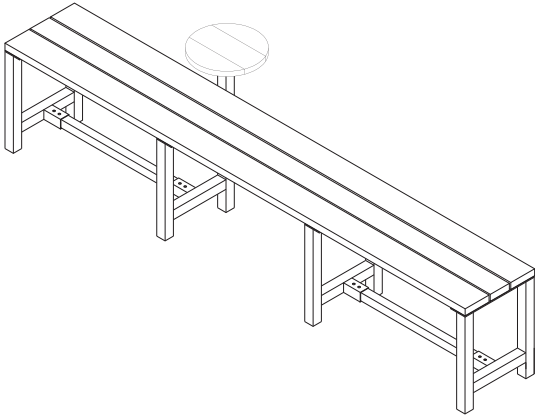

QUAD NO. 3



Add more extension tables for a little extra personality.

DESCRIPTION

QUAD No. 3 takes our standard bench and offers a unique feature for holding a beverage or a place to write.

Spacious enough to hold up to 4-5 people.

DIMENSIONS

Seat Height: 19.25"

Back Height: N/A

Width: 80"

Depth: 16.5"

MATERIALS

Powder coated steel tube contrast soft woods rescued from the Angeles National Forest after the Bobcat Fire of 2020, sealed with a hardwax oil, exterior finish.

POWDER COAT COLORS



FINE POINTS

“The details are not the details. They make the design.”

QR CODE

Each furniture piece in our collection receives a QR code inlay that links residents directly to our website where an individual may learn more about our paid job-training program and apply to take part in our bi-annual cohorts.



PARTNERSHIPS

Angel City Lumber seeks to reset a sense of connected reverence for the sublime beauty of the living world through working solely with felled LA County trees.



This project was partially funded through the **USDA Forest Service Wood Innovations Grant**. Would Works is an equal opportunity provider.

