



**Envisat Coastal Altimetry Product
Handbook**

Reference
ESA: **ENVI-DTEX-EOPS-TN-09-0006**
Issue: 2.0.1
Date: 16 September 2011

Revision History:		
Issue:	Date:	Reason for change:
1 rev 0	25 November 2009	Initial Issue
1 rev 1	17 December 2009	Moved tables of pass numbers to Appendix
1.1	22 March 2010	Release to match v1.1 of the output product
2.0	11 July 2011	<p>Updated to correspond to v2.0 rev2 products</p> <p>Addition of new applicable documents for wet tropospheric correction, latest specification, extension orbit and level 2 processing</p> <p>Added information on Envisat extension orbit phase</p> <p>Added information on IPF & CMA processing version for 2010</p> <p>Added description of GPD wet tropospheric correction and related fields</p> <p>Added description of distance from coast field</p> <p>Added Case Studies</p> <p>Corrected and updated References</p> <p>Corrected and updated Acronyms</p>
2.0.1	16 September 2011	<p>Corrected page formatting (missing headers and missing or incorrect page numbers)</p> <p>Corrected table formatting for consistency throughout</p> <p>Corrected in response to ESA RID:</p> <ul style="list-style-type: none"> - minor typographic corrections throughout - added §3.3.1 on the COASTALT processor and references to applicable documents - added thermal noise term and added or corrected definition for terms in equation 1&2 - Replaced equation 5 with correct equation - Removed reference to Maximum Likelihood Estimator (MLE) - Corrected references to §3.5 and §3.5.2 (from §0)

Contributors to this issue:		
<p>Written by: H. SNAITH</p> <p>Revised by: P. CIPOLLINI</p>	NOC-S	<p>Date July 2011</p>



List of tables and figures

List of tables:

Table 2-1 Envisat budgets	7
Table 2-2 RA-2 Characteristics.....	8
Table 2-3 Envisat 35-day phase orbit parameters	10
Table 2-4 Definition of cycle numbering for the Envisat mission.....	11
Table 3-1 RA-2 Products	13
Table 3-2 Software Versions used to generate the latest Envisat SGDR products [AD 8].....	15
Table 3-3 IPF software version changes affecting SGDR products [AD 8; AD 9].....	16
Table 3-4 CMA software version changes affecting SGDR products [AD 8; AD 9]	17
Table 3-5 Models and standards.....	19
Table 4-1 Available range values in the CGDR.....	31
Table 4-2 Available wet tropospheric correction values in all CGDR products.....	32
Table 4-3 Additional wet tropospheric correction values in a limited number of enhanced CGDR products	32
Table 4-4 Available ionospheric correction values in the CGDR	33
Table 4-5 Available ocean tide correction values in the CGDR	35
Table 4-6 Recommended editing criteria	37
Table 4-7 General Quality Flags Available in the CGDR Products	38
Table 4-8 Definition of variable meas_conf_data_flags	39
Table 4-9 Definition of variable instr_flags.....	40
Table 4-10 Definition of variable mwr_instr_flag.....	41
Table 4-11 Definition of variable interpolate_flag.....	41
Table 4-12: Variable-specific flags available in the CGDR products	42
Table 4-13 Other quality Control Variables.....	43
Table 4-14 Additional quality control variables for GPD correction (in limited regional enhanced CGDRs)	43
Table 7-1 Dimensions used in the CGDR data sets	63
Table 7-2 netCDF variable types.....	63
Table 7-3 Variables included in the CGDR products. Variables calculated or mapped to two dimensions by the COASTALT processor are shown in <i>italics</i>	64
Table 7-4 Additional variables included in some limited region enhanced CGDR products.	69
Table 7-5: Variable attributes.....	70
Table 7-6 Global Attributes used in CGDR files.....	72
Table A-1 Equator Crossing Longitude and Time (in order of Pass Number) (the longitudes are the average values for cycles 10 – 79) (RO = Relative Orbit, P = Pass, D = Day Shift)	xv
Table A-2 Equator Crossing Longitude and Time (in order of Longitude) (the longitudes are the average values for cycles 10 – 79) (RO = Relative Orbit, P = Pass, D = Day Shift)	xix

List of figures:

Figure 1 Altimetric distances – relationship between altitude, range and height.....	3
Figure 2: Impact of the inclination drift for the same track of two successive cycles (exaggerated inclination change). [AD 12]	4
Figure 3: RA-2 Product Tree	14
Figure 4: Examples of 18Hz Ku-band waveforms in the coastal zone in the North-West Mediterranean test site (from AD 11).....	24
Figure 5: Typical configuration for a “long” radiometric wet tropospheric correction gap .	25
Figure 6: Configuration for short (less than 60km) radiometer data gap or contamination by land located across-track from nadir.	26
Figure 7: retracked heights (—) plotted as along-track anomalies for identification of anomalous along-track measurements (○) close to the coast.....	54
Figure 8: Map of the number of cycles identified as having outlying values	55
Figure 9: Number of the along-track points (in Figure 8) for which each ENVISAT cycle was identified as outlying (exceeding 2.5 the standard deviation of the SLA series) ..	56
Figure 10: Standard deviation of differences between COASTALT and tide gauge values at the Cascais tide gauge for the three wet troposphere corrections.....	57
Figure 11: Location of the study area showing ENVISAT track 223 and the AWAC (A) and Gulf of Cadiz (G) coastal buoys. Ground tracks are depicted with yellow dots indicating the position of the 1 Hz measurements (Google Earth copyright).	58
Figure 12: Statistics (rms, bias and R) resulting from the comparisons of significant wave height from the altimeter products against in-situ observations from the AWAC coastal buoy with respect to the distance to coast. Continues lines correspond to SGDR datasets and dashed lines to COASTALT CGDR. The distance to in-situ emplacement of each track point in the bottom of the plot.....	60
Figure 13: Comparison of significant wave height records from the AWAC coastal buoy versus altimeter 1 Hz of track point 4 from the SGDR data (dots) and of track point 5 from COASTAL measurements (crosses).....	60



Contents

1	Introduction	1
1.4.1	Vocabulary.....	2
1.4.1.1	Altimetric distances.....	2
1.4.1.2	Orbits, Revolutions, Passes, and Repeat Cycles.....	3
1.4.1.3	Reference Ellipsoid.....	4
1.4.2	Correction Conventions.....	5
1.4.3	Time Convention.....	5
1.4.4	Unit Convention.....	5
1.4.5	Flagging and Editing.....	5
2	Envisat Mission Overview.....	6
2.3.1	ASAR.....	7
2.3.2	MERIS.....	7
2.3.3	AATSR.....	8
2.3.4	RA-2.....	8
2.3.4.1	Measurement Mode.....	8
2.3.4.2	RF and Digital BITE Mode.....	9
2.3.4.3	IF Calibration Mode.....	9
2.3.5	MWR.....	9
2.3.6	GOMOS.....	9
2.3.7	MIPAS.....	9
2.3.8	SCIAMACHY.....	9
2.3.9	DORIS.....	10
2.3.10	LRR.....	10
3	Envisat RA-2 Products.....	13
3.3.1	The COASTALT Processor.....	18
3.5.1	COASTALT retracker.....	21
3.5.1.1	Retracker 1: Brown theoretical ocean retracker (BOR).....	21
3.5.1.2	Retracker 2: Specular Beta-parameter retracker (SBE).....	22
3.5.1.3	Retracker 3: Mixed Brown Specular retracker (MBS).....	23
3.5.2	Wet Tropospheric Correction from Dynamically Linked Model.....	25
3.5.2.1	"Long" (>60km) radiometric wet tropospheric correction gap.....	25
3.5.2.2	"Short" (<60km) or "ocean-only" wet tropospheric correction gap.....	26
3.5.2.3	Use of the DLM in the CGDR.....	27
3.5.3	Distance from coast.....	27
4	Using the CGDR data	28
4.3.1	Corrected Altimeter Range.....	31
4.3.1.1	Range:.....	31
4.3.1.2	Wet Troposphere Correction.....	32
4.3.1.3	Dry Troposphere Correction.....	32
4.3.1.4	Ionosphere Correction.....	33
4.3.1.5	Sea State Bias Correction.....	33

4.3.2	Sea Surface Height and Sea Level Anomaly	34
4.3.2.1	Altitude.....	34
4.3.2.2	Corrected Range.....	34
4.3.2.3	Tide Effects	34
4.3.2.4	Surface Air Pressure Effects.....	36
4.3.2.5	Geophysical Surface - Mean Sea Surface or Geoid.....	36
4.3.3	Data Editing Criteria	37
4.3.3.1	Use of Flags.....	37
4.3.3.2	Detection of S-Band Anomaly.....	43
4.3.4	Mean Sea Surface and Adjustment of the Cross Track Gradient	44
4.3.5	Smoothing Ionosphere Correction	44
4.3.6	Generation of 1 Hz Averages.....	45
5	Altimetric data.....	46
5.5.1	Troposphere (dry and wet)	48
5.5.2	Ionosphere	49
5.5.3	Ocean Waves (sea state bias).....	49
5.7.1	Geocentric Ocean Tide	50
5.7.2	Long period Ocean Tide	51
5.7.3	Solid Earth Tide	51
5.7.4	Pole Tide	51
5.8.1	Inverted Barometer Correction	52
5.8.2	Barotropic/Baroclinic Response to Atmospheric Forcing.....	52
6	Coastal Case Studies.....	54
7	Data description.....	62
7.1.1	The NetCDF Data Model	63
7.1.1.1	Dimensions.....	63
7.1.1.2	Variables.....	63
7.1.1.3	Coordinate variables and auxiliary coordinate variables.....	69
7.1.1.4	Attributes	70
7.1.2	The Common Data Language	71
7.1.3	CF convention.....	72
7.4.1	Software provided with netCDF: “ncdump”	75
7.4.2	netCDF Utilities	75
7.4.2.1	ncbrowse.....	75
7.4.2.2	netCDF Operator (NCO).....	75
7.4.3	Specialist Altimetry Software : BRAT	75
Annexe A	References	vii
Annexe B	List of acronyms	xii
Annexe C	Envisat 35-day Repeat Phase Pass Definitions	xiv

1 Introduction

Envisat is the follow-on altimetry mission to ERS-1 and ERS-2, with altimetry measurements generated by the RA-2 radar altimeter. The mission supports ten different onboard instruments dedicated to the global observation of our environment.

This manual is designed to support those using the RA-2 radar altimeter and the MWR microwave radiometer *in the coastal zone* – specifically enclosed and semi-enclosed seas, and ocean within 200 km of the coast.

1.1 Scope of the document

The purpose of this document is to assist users of the COASTALT (ESA development of COASTal ALTimetry) Coastal Geophysical Data Record (CGDR) products by providing a comprehensive description of product content and format, together with supporting information on the altimetry measurement system in the coastal zone and how to use this new product.

The COASTALT products are based on the Envisat Sensor Geophysical Data Record (SGDR) products [AD 2], which are fully validated Level 2 products. The new data within the COASTALT product are experimental in terms of content and have not been validated. Hence the CGDR product is a mix of validated and experimental content, and users should be cautious in interpreting their results, particularly where the new content has been used.

The SGDR products, including algorithms and auxiliary data used in their production, are described in a series of documents [AD 1, AD 2, AD 3, AD 4 and AD 5]. This Handbook will not attempt to reproduce this information in full, but will reference appropriate sections. However, some sections may be reproduced for clarity.

This document will concentrate on new elements included in the CGDR products and how they may be compared to the source SGDR outputs included in the CGDR.

1.2 Handbook Overview

This document is a combination of a guide to data use and a reference handbook and not all readers will need to use all the sections.

- Section 1** provides background information about the COASTALT products and this document
- Section 2** is an overview of the Envisat mission and the COASTALT initiative
- Section 3** provides information of product evolution history
- Section 4** is an introduction to using the COASTALT data, including recipes for generating commonly required outputs, such as sea level.
- Section 5** is an introduction to the COASTALT altimeter algorithms
- Section 6** provides case studies for the use of COASTALT products.
- Section 7** provides a description of the content and format of the COASTALT products.
- Annexe A** contains references
- Annexe B** contains acronyms
- Annexe C** contains tables of the ENVISAT 35-day repeat pass definitions



1.3 Document reference and contributors

When referencing this document, please use the following citation:

“ENVISAT Coastal Product Handbook”,
ENVI-DTEX-EOPS-TN-09-0006

This document has been collated and edited by Helen Snaith, with material sourced from the ENVISAT Product Handbook [AD 1], ESA’s ENVISAT web pages [<http://earth.esa.int/envisat>] and the Jason-2 Handbook [RD 14], with permission. Other contributors are Susana Barbosa (case studies over W Iberia), Jesus Gómez-Enri (case study over Gulf of Cadiz) and Paolo Cipollini.

1.4 Conventions

1.4.1 Vocabulary

1.4.1.1 Altimetric distances

In order to reduce confusion in discussing altimeter measurements and corrections, the following terms are used in this document as defined below:

Distance and **Length** are general terms with no special meaning in this document.

Height is the distance above a reference surface. The reference surface used is the *reference ellipsoid* (see §1.4.1.3). Positive is upwards (away from the centre of the earth).

Range is the distance from the satellite to the surface of the Earth, as measured by the altimeter. Thus, the altimeter measurement is referred to as "range" or "altimeter range," not height.

Altitude is the *height* of the satellite or altimeter, usually given as the height of the centre of mass of the satellite. This distance is computed from the satellite orbit (ephemeris) data.

Sea Surface Height is the *height* of the sea surface. The sea surface height is the difference of the altimeter range from the satellite altitude. Strictly, it is the difference of the altimeter range, corrected for atmospheric delays, from the satellite altitude.

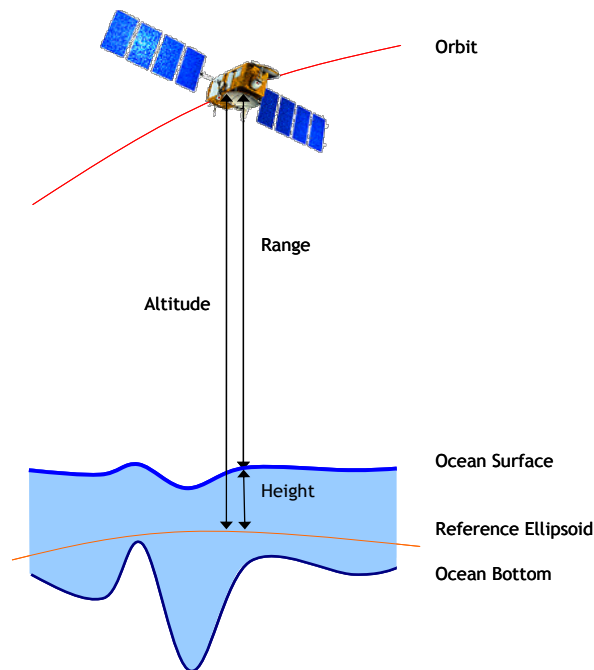

Figure 1 Altimetric distances – relationship between altitude, range and height

The Geoid is an equipotential surface – *i.e.* a surface along which the gravity potential remains constant. The shape of this surface is controlled by the earth's gravity field.

Sea Surface Topography, or dynamic topography, is that part of the sea surface height caused by ocean currents. It is equal to the departure of the *sea surface height* from the *geoid* height, once geophysical effects, such as tides, atmospheric pressure effects and sea state bias have been removed.

1.4.1.2 Orbits, Revolutions, Passes, and Repeat Cycles

An **Orbit** is one circuit of the earth by the satellite as measured from one ascending node crossing to the next. An **ascending node** occurs when the sub satellite point crosses the earth's equator going from south to north. A **Revolution** (REV) is synonymous with orbit.

A **Pass** is half a revolution of the earth by the satellite from extreme latitude to the opposite extreme latitude. For altimetry data, it is normal to organize data by pass to avoid having data boundaries in the middle of the oceans. Ascending passes are odd numbered and descending passes are even numbered. For Envisat, an **Ascending Pass** begins at latitude -82° and ends at $+82^\circ$. A **Descending Pass** is the opposite ($+82^\circ$ to -82°).

From launch until 22 October 2010, Envisat maintained a **35 day exact repeat cycle**. During this phase, after each **repeat cycle** of 1002 passes, taking 35 days, Envisat revisited the same ground-track within a margin of ± 1 km. That means that every location along each pass of the Envisat ground-track was measured every 35 days.

On 2 November 2010 Envisat began a new phase, with a **30 day near-repeat cycle**. During this extension orbit phase, there are 862 passes per cycle. The inclination of the orbit is not maintained and hence the ground tracks are not repeated exactly, but with slight changes in inclination. The inclination drift induces a rotation of the orbital plane around 38° (North for descending tracks, South for ascending tracks), hence at these latitudes there is no longitudinal drift of the tracks and they will repeat almost exactly. For other latitudes, the

passes will drift over time, as shown in Figure 2. The resultant drift at the equator is expected to be approximately 15 km over 3 years.

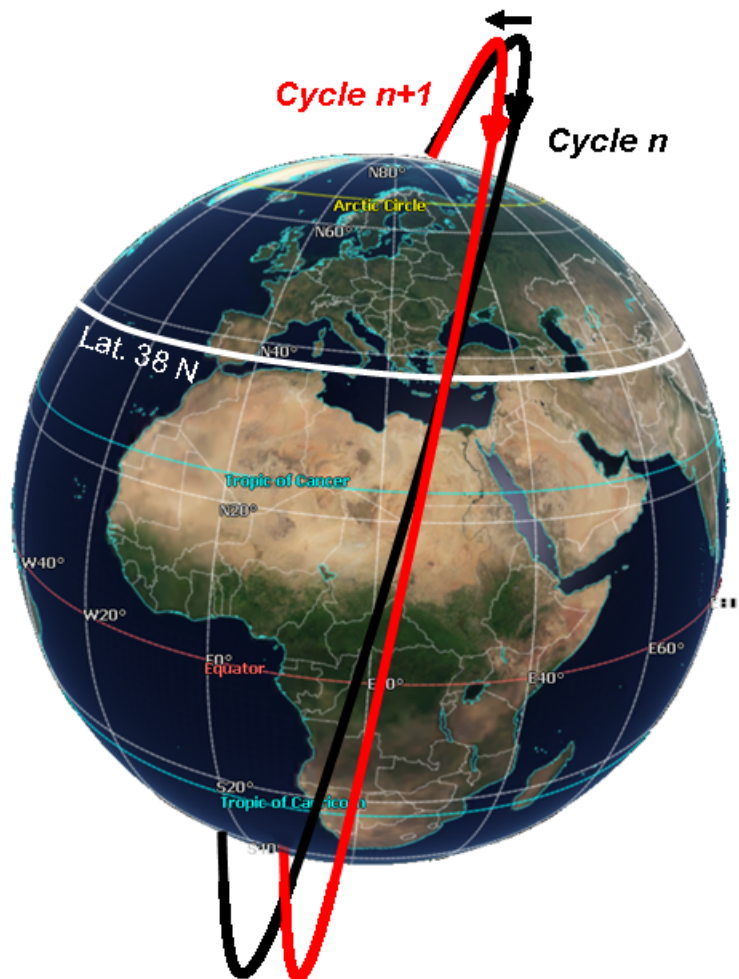

Figure 2: Impact of the inclination drift for the same track of two successive cycles (exaggerated inclination change). [AD 12]

The passes are numbered 1 to 1002 for the 35-day phase and 1 to 862 for the 30-day phase, with pass number 1 defined as the pass that has its ascending node closest to zero longitude (actually 0.1355°E for the 35-day phase, 0.6°E, drifting west with time for the 30-day phase) and the cycles are defined so that this is the first pass within a cycle.

Important note – there is potential for confusion as the orbits are numbered starting from the northward equator crossing, but the ascending pass is numbered from the southern extreme of the orbit, hence an ascending pass, strictly, includes the data from two consecutive orbits (the last quarter of one orbit and the first quarter of the following orbit). This has led to confusion in the file naming convention, as explained in §4.2.

1.4.1.3 Reference Ellipsoid

The **Reference Ellipsoid** is a first-order definition of the non-spherical shape of the Earth as an ellipsoid of revolution. The reference ellipsoid used for the Envisat mission is the WGS84 ellipsoid, defined as having an equatorial radius of 6378.137 km and a flattening coefficient of 1/298.2572236.

1.4.2 Correction Conventions

All environmental and instrument corrections are computed so that they should be **added** to the quantity which they correct. That is, a correction is applied to a measured value by

Corrected Quantity = Measured Value + Correction

This means that a correction to the altimeter range for an effect that lengthens the apparent signal path (e.g., wet troposphere correction) is computed as a negative number. Adding this negative number to the uncorrected (measured) range reduces the range from its original value toward the correct value.

Example: Corrected Range = Measured Range + Range Correction.

Similarly, any value reported as a *difference* should be added to the average value to give the full value.

Example: <18 Hz latitude> = <1 Hz averaged latitude> + <18Hz latitude differences from 1Hz>

1.4.3 Time Convention

Times are UTC and referenced to **January 1, 2000 00:00:00.00**.

For information on how leap seconds are dealt with, see AD 2.

1.4.4 Unit Convention

Wherever possible, values are reported in SI units, as defined in the UD-units package (where the definitions exist), so as to be compliant with the CF-conventions (see §7.1.3). All distances and distance corrections are reported in meters, although this may require application of a scale factor, as reported in the product, with the exception of the distance from coast, which is reported in km.

1.4.5 Flagging and Editing

Flags are used to convey quality information or operating modes. They are usually set to zero to mean 'OK' and 1 for 'not OK'. Any spare flags are set to zero. There may be exceptions, in which case a particular description of the flag's use is provided. For example, flags may be used to provide information on the operation mode of the instrument. The flag values and flag meanings of simple flags are defined in their attributes in the CGDR products. For complex flags the user should refer to the ENVISAT handbook for the definition, or §4.3.3.1 has summary definitions.

Additional editing is usually required to determine the data quality. In some cases, flags have been pre-determined, using quality criteria *e.g.* data exceeding given thresholds. However, in most cases, users will also need to apply their own data quality editing criteria. The criteria recommended for the SGDR data are given in §4.3.3. There are, as yet, no modifications to these criteria for the new parameters in the CGDR products.



2 Envisat Mission Overview

2.1 Background

Envisat (ENVironmental SATellite) is an advanced polar-orbiting Earth observation satellite, launched in March 2002, which provides measurements of the atmosphere, ocean, land and ice. The Envisat satellite has an ambitious and innovative payload that ensures the continuity of the data measurements of the ERS satellites. The Envisat data supports Earth science research and allows monitoring of the evolution of environmental and climatic changes.

Its primary objectives are:

- to provide for continuity of the observations started with the ERS satellites, including those obtained from radar-based observations;
- to enhance the ERS mission, notably the ocean and ice mission;
- to extend the range of parameters observed to meet the need of increasing knowledge of the factors determining the environment;
- to make a significant contribution to environmental studies, notably in the area of atmospheric chemistry and ocean studies (including marine biology).

These are coupled with two linked secondary objectives:

- to allow more effective monitoring and management of the Earth's resources;
- to better understand solid Earth processes.

The mission intends to continue and improve upon measurements initiated by ERS-1 and ERS-2, and to take into account the requirements related to the global study and monitoring of the environment.

The mission is an essential element in providing long-term continuous data sets that are crucial for addressing environmental and climatological issues. It will at the same time further promote the gradual transfer of applications of remote sensing data from experimental to preoperational and operational exploitation.

Envisat, as an undertaking of ESA member states plus Canada, constitutes a major contribution to the international effort of space agencies worldwide to provide the data and information required to further the understanding, modelling, and prediction of environmental and climatic changes.

2.2 Satellite Description

Envisat is a very large platform, when compared to other altimeter mission platforms, due to its multi-sensor objectives. This has consequences for the orbit determination and other factors important for precision altimetry.

The major driver for the Envisat satellite configuration was the need to maximise the payload instrument mounting area and to meet the viewing requirements within the constraints of the Ariane 5 fairing and interfaces. The overall satellite budgets for Envisat are given in Table 2-1

Table 2-1 Envisat budgets

Launch configuration		
Dimensions		
Launch Configuration,	length 10.5 m envelope diameter 4.57 m	
In-Orbit configuration	26 m * 10 m * 5 m	
Mass Budget		
Service Module	2673 kg	
Payload Equipment Bay	1021 kg	
Payload Carrier	2078 kg	
Fuel	319 kg	
Payload Instruments	2118 kg	
Total	8211 kg	
Power Budget		
	Average Power (W)	
	Sunlight	Eclipse
Payload	1841	1886
Payload Module	860	527
Service Module	859	684
Total Load	3560	3097
System Capability	3847	3291

2.3 Sensors

Envisat carries nine instruments, which are summarized below. The key instruments for altimetry are the Radar Altimeter (RA-2), the Microwave Radiometer (MWR), DORIS (Doppler Orbitography and Radio-positioning Integrated by Satellite) and the Laser Retroreflector (LRR) (used for precision orbit determination).

2.3.1 ASAR

An Advanced Synthetic Aperture Radar (ASAR), operating at C-band, ASAR ensures continuity with the image mode (SAR) and the wave mode of the ERS-1/2 AMI.

2.3.2 MERIS

MERIS is a programmable, medium-spectral resolution, imaging spectrometer operating in the solar reflective spectral range. Fifteen spectral bands can be selected by ground command, each of which has a programmable width and a programmable location in the 390 nm to 1040 nm spectral range.



2.3.3 AATSR

The prime scientific objective of the Advanced Along Track Scanning Radiometer (AATSR) is to establish continuity of the ATSR-1 and ATSR-2 data sets of precise sea surface temperature (SST), thereby ensuring the production of a unique 10 year near-continuous data set at the levels of accuracy required (0.3 K or better) for climate research and for the community of operational as well as scientific users who have been developed through the ERS-1 and ERS-2 missions.

2.3.4 RA-2

The Radar Altimeter 2 (RA-2) is an instrument for determining the two-way delay of a radar echo from the Earth's surface to a very high precision: less than a nanosecond.

If the orbit of the satellite is determined by independent means (such as by DORIS) the RA-2 data can be used to accurately map the Earth's topography. In addition, signal analysis of the returning radar echo can be used to provide insight into ground characteristics. The RA-2 is a nadir looking pulse limited radar operating at a nominal frequency of 13.575 GHz (Ku-band). A second channel, operating at a nominal frequency of 3.2 GHz (S-band) is also used, primarily to estimate the effects of the ionosphere on the Ku-band channel.

Note: the S-band of the RA-2 ceased functioning on 18 January 2008 and since then the RA-2 has been operated as a single frequency altimeter.

Table 2-2 RA-2 Characteristics

GEOMETRIC:	Approx. 19 km footprint. Spatial sampling approx. 390 meters along track. 47 cm height resolution at 320 MHz max chirp bandwidth.
RADIOMETRIC:	Nadir looking pulse: Main Nominal frequency = 13.575 GHz (Ku-band) Error Nominal frequency = 3.2 GHz (S-band)

The RA-2 Instrument operates in three modes. These consist of Measurement Mode, RF and Digital Built-In Test Equipment (BITE) Mode, and IF Calibration Mode. Science data is gathered within the Measurement Mode, while the other modes are used for testing and calibration of the instrument.

2.3.4.1 Measurement Mode

The Measurement Mode consists of two primary phases. The first is Acquisition Phase, when the instrument attempts to locate the initial ground height. To do this, the instrument first initiates a Noise Power Estimation cycle to establish a noise power estimate, then proceeds with a Detection cycle in which the location of the leading edge of the return echo is established. The final step in the Acquisition Phase is the Automatic Gain Control (AGC) Setting cycle in which the instrument attempts to estimate the received signal power in order to set the appropriate gain settings needed to keep the return signal amplitude within the proper dynamic range of the receiving equipment. The second step of Measurement Mode is the Tracking Phase, in which the instrument acquires the science data. The transition from Acquisition to Tracking phases is performed automatically or started directly by macrocommand. During tracking it is possible to change tracking parameters without

interruption of measurements. Periodic calibration is also performed while in the Tracking Phase of Measurement Mode. Operational products are constructed from the data obtained when the instrument is in the Tracking Phase of Measurement mode.

2.3.4.2 RF and Digital BITE Mode

The aim of these two modes is to test the RF Tx/Rx channel and the digital signal processing modules. BITE is executed from Measurement Mode by macrocommand. During BITE the tracking is interrupted. RF and Digital BITE are executed cyclically until a mode change request is received. Data generated while in this mode are included in Level 0 Products only.

2.3.4.3 IF Calibration Mode

The purpose of this mode is to measure the IF filter shape. This is done by measuring the spectra of averaged noise samples. Data generated while in this mode are included in Level 0 Products only.

2.3.5 MWR

The main objective of the microwave radiometer (MWR) is the measurement of atmospheric humidity as supplementary information for tropospheric path correction of the radar altimeter signal, which is influenced both by the integrated atmospheric water vapour content and by liquid water. In addition, MWR measurement data are useful for the determination of surface emissivity and soil moisture over land, for surface energy budget, investigations to support atmospheric studies, and for ice characterisation.

The MWR instrument on board Envisat is a derivative of the radiometers used on the ERS-1 and ERS-2 satellites. It is a dual-channel nadir-pointing Dicke-type radiometer, operating at frequencies of 23.8 GHz and 36.5 GHz.

2.3.6 GOMOS

GOMOS measures atmospheric constituents by spectral analysis of the spectral bands between 250 nm to 675 nm, 756 nm to 773 nm, and 926 nm to 952 nm. Additionally, two photometers operate in two spectral channels; between 470 nm to 520 nm and 650 nm to 700 nm, respectively.

2.3.7 MIPAS

The Michelson Interferometer for Passive Atmospheric Sounding (MIPAS) is a Fourier transform spectrometer for the measurement of high-resolution gaseous emission spectra at the Earth's limb. It operates in the near to mid infrared where many of the atmospheric trace-gases playing a major role in atmospheric chemistry have important emission features.

2.3.8 SCIAMACHY

SCIAMACHY is an imaging spectrometer whose primary mission objective is to perform global measurements of trace gases in the troposphere and in the stratosphere.



2.3.9 DORIS

The Doppler Orbitography and Radio-positioning Integrated by Satellite instrument is a microwave tracking system that can be utilized to determine the precise location of the Envisat satellite. DORIS operates at dual frequency and so also provides information on ionospheric electron content that can be used to determine the delay to the RA-2 signal due to the ionosphere.

2.3.10 LRR

The LRR is a passive device, which is used as a reflector by ground-based SLR stations using high-power pulsed lasers. In the case of Envisat, tracking using the LRR is principally accomplished by the International Laser Ranging Service (ILRS).

2.4 Orbit

Envisat flies in a sun-synchronous polar orbit of about 800-km altitude. The repeat cycle of the reference orbit for the primary phase was 35 days, and for most sensors, being wide swath, it provided complete coverage of the globe within one to three days. The exceptions are the profiling instruments MWR and RA-2, which do not provide real global coverage, but span a tight grid of measurements over the globe. This grid is the same 35-day repeat pattern as that established by ERS-1 and ERS-2.

The mean classical orbit elements for the 35-day phase are given in the table below.

Table 2-3 Envisat 35-day phase orbit parameters

Orbit parameter	Value
Orbits per Day	14 11/35
Repeat Cycle (days)	35
Orbits in Cycle	501
Orbit Period (min)	100.59
Mean Local Solar Time at descending node	10:00
Inclination (deg)	98.55
Semi-Major Axis [Orbit Radius] (km)	7159.5
Orbit Velocity (km/s)	7.45
Mean Altitude (km)	799.8
Orbital Altitude Range (km)	780 - 820

The orbit maintenance requirements during the primary phase were that the deviation of the actual ground track from the nominal one was kept below 1 km and that the mean local nodal crossing time matched the nominal one to better than five minutes. The requirements for the extension phase have been relaxed so that there is no requirement for an exact repetition of the ground track and the mean local nodal crossing time is to match the nominal one to better than 10 minutes.

The orbit maintenance strategy aims for minimum disturbance of the payload operation. In-plane manoeuvres are used for altitude adjustment to compensate for the effects of air-drag.

This altitude decay controls the ground-track repeatability, mainly in the equatorial regions. The frequency of these manoeuvres is determined by the rate of orbital decay, which is in turn determined by the air density, and this is a function of solar activity. The nominal rate for these in-plane manoeuvres is twice a month. They do not interrupt the operations of most sensors.

During the 35-day exact repeat phase, out-of-plane corrections were used to correct the steady drift of inclination mainly caused by solar and lunar gravity perturbations. The solar wind also influences the inclination, but its contribution is typically one order of magnitude smaller than the one given by solar and lunar gravity. Inclination drift degrades the ground-track maintenance at high latitudes. The drift rate does not depend on air density and corrections were required every few months. As they are out-of-plane they require a 90 degree rotation of the spacecraft, to align the thrusters with the required thrust direction, and so these manoeuvres were performed in eclipse to avoid the risk of optical sensors viewing the sun.

During the extension orbit phase, from 2 Nov 2010, the orbit altitude was reduced to 782.4 km and, in order to save fuel and so extend the life of the satellite, the out-of-plane corrections that prevent inclination drift have been stopped. The resultant orbit has a 30-day 'near repeat' of 431 orbits per cycle, with minimal drift at 38°N (for descending tracks) and 38°S (for ascending tracks) (see Figure 2).

Table 2-4 Definition of cycle numbering for the Envisat mission

Cycle	First absolute orbit	Last absolute orbit	ANX UTC
1	1	19	01 Mar 2002 02:53:55
2	20	369	02 Mar 2002 10:45:18
3	370	485	26 Mar 2002 21:59:53
4	486	555	04 Apr 2002 00:37:34
5	556	1056	08 Apr 2002 21:59:29
6	1057	1557	13 May 2002 21:59:29
7	1558	2058	17 Jun 2002 21:59:29
8	2059	2559	22 Jul 2002 21:59:29
9	2560	3060	26 Aug 2002 21:59:29
10	3061	3561	30 Sep 2002 21:59:29
...
94	45145	...	18 Oct 2010 21:59:59
95	...	45272	
96	45273	45703	27 Oct 2010 21:59:29
97	45704	46134	26 Nov 2010 21:59:59
...

The definition of the orbit numbering and cycles, as given in §1.4.1.2, is that the first relative orbit within a cycle is the orbit with the smallest offset from zero longitude. However, the absolute orbit number is continuous from the beginning of the mission. As the satellite was not injected directly into its final operational orbit, there are several cycles at the beginning of the mission where cycles did not contain 501 orbits (1002 passes) and the relationship of



absolute to relative orbit number is not simple. Table 2-4 shows the definition of the cycle numbering used for Envisat over the first 10 cycles. From cycle 5 onwards, the platform was in its primary repeat orbit and hence for cycle 5 until cycle 94, the relationship between relative orbit, cycle and absolute orbit can be given as:

$$\text{Absolute orbit} = \text{relative orbit} + ((\text{cycle} - 5) * 501) + 555$$

The relative orbits within each 35-day cycle (from cycles 5 - 94) are defined by their equator crossing longitudes and times, as given in Table A-1 and Table A-2 . The track separation is 0.719° longitude between adjacent tracks in the same sense (ie between adjacent ascending or descending passes).

Cycle 95 covered the orbit manoeuvres to transfer Envisat to the extension orbit phase, with its 30-day near-repeat orbit. There are no altimetry data between 22 October and 2 November 2010 whilst the manoeuvres were carried out.

For the extension orbit phase, the relationship between relative orbit, cycle and absolute orbit can be given as:

$$\text{Absolute orbit} = \text{relative orbit} + ((\text{cycle} - 96) * 431) + 45272$$

The track separation during the extension orbit phase is 0.835° longitude between adjacent tracks in the same sense.

3 Envisat RA-2 Products

3.1 RA-2 Data Processing

The RA-2 series of products is summarized in Table 2-1 and the product tree of Figure 3.

Table 3-1 RA-2 Products

Product ID	Description
RA2_CAL_OP	RA2 Calibration and BITE Mode Level 0
RA2_ME_OP	RA2 Measurement Mode Level 0
RA2_MW_1P	Geolocated and calibrated Altimeter Waveforms with TOA Microwave Brightness Temperatures
RA2_FGD_2P	FDGDR: Fast delivery Geophysical Data record from RA-2 and Water Vapour/Liquid Content from MWR. Available 3 hours after data acquisition
RA2_IGD_2P	IGDR: Intermediate Geophysical Data record from RA2 and Water Vapour/Liquid Content from MWR. Processed off-line and available 3-5 days after acquisition
RA2_GDR_2P	GDR: Geophysical Data Record from RA-2 and Water Vapour/Liquid Content from MWR. Processed off-line and available 50 days after acquisition
RA2_WWV_2P	FDMAR/IMAR: Wind/Wave product with height and MWR information for NRT dissemination to Meteocean users (2 products released at different levels of consolidation: FDMAR built from RA2_FGD_2P or IMAR built from RA2_IGD_2P)
RA2_MWS_2P	SGDR: Sensor Geophysical Data Record from RA-2, Water Vapour/Liquid content from MWR and Individual Uncalibrated Waveforms from RA-2. Available after 50 days from data take.

The COASTALT processor uses data from the level 2 SGDR product (RA2_MWS_2P) to generate the output product. This product contains 1 Hz averaged and 18 Hz RA-2 and MWR data, as well as 1 Hz geophysical corrections and flags. The SGDR also contains the 18 Hz waveform data used by the COASTALT processor.

Important Note: the "1 Hz" averages are actually averages of 20 18 Hz samples, and as such are at 0.9 Hz. However, they are referred to as 1 Hz for simplicity and for comparison with the equivalent averaged values from other altimetric missions.

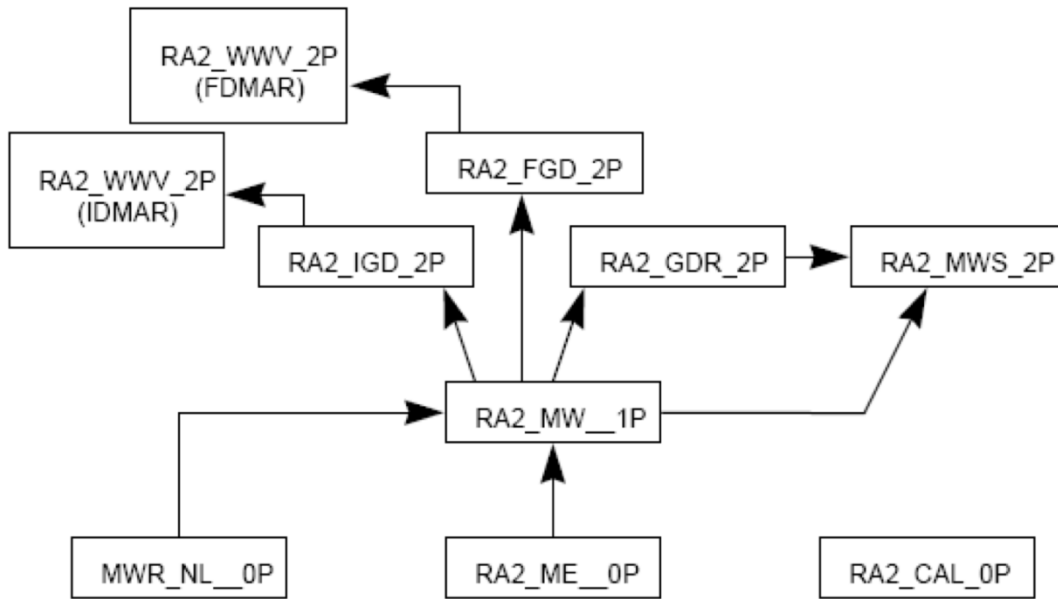

Figure 3: RA-2 Product Tree

3.2 Product History

The precise content of the Level 2 product is determined by the CMA (level 2) processing software version, and also by the software versions used to generate the lower level products, in particular the level 1B, IPF, software version. The software version of the level 2 (CMA) processing chain is included in the SGDR header information, and is retained in the CGDR global attributes. However, the Level 1B (IPF) software version information has only been included in the SGDR data since CMA version 7.1 and is not yet included in the CGDR products. The versions of the software used to generate the latest SGDR products are given in Table 3-2 and the changes to software version, as they affect the SGDR data, are given in Table 3-3 and Table 3-4.

Table 3-2 Software Versions used to generate the latest Envisat SGDR products [AD 8]

Cycles	IPF version	CMA version
9 to 10	4.58	6.3
11 to 12	4.57	6.3
13 to 15	4.56	6.3
16 to 18	4.54	6.1
19 to 24	4.56	6.2
25 to 26	4.56	6.3
27 to 28	4.57	6.3
29 to 37	4.58	6.3
38 to 47p790	5.02	7.1
47p791 to 48p849	5.06	9.0
48p850 to 51p007	5.02	7.1
51p008 to 58p843	5.03	8.0
58p844 to 64	5.06	9.0
65 to 67	5.06	9.1
68 to 84	5.06	9.2
85-	6.02L04	9.3.02

Where the change in version occurs within a cycle, the last, or first, pass within that cycle that a version applies to is denoted using p<pass>

The change from IPF 4.58/CMA6.3 to IPF 5.02/CMA7.1 was significant, with a recomputed Sea-State bias table to account for the impact of the new orbit and the new geophysical corrections (MOG2D, GOT00 ocean tide correction with the S2 component corrected once only, new wind speed algorithm [RD 1]). The new SSB correction is shifted by approximately +2.0 cm from the previous one. New standards are used for the computation of the Envisat Precise Orbit Estimation. One of the main evolutions is the use of the GRACE gravity model EIGEN GC03C. This new model implies a strong reduction of the geographically correlated radial orbit errors. In order to take into account the dynamical effects and wind forcing, a new correction is computed from the MOG2D barotropic model [RD 6] forced by pressure (without S1 and S2 constituents) and wind.

Other changes are less significant, but impact on the resultant height data can still be seen.

There are specific issues in some software versions, regarding the availability of particular header data or variables.

Note: For CMA versions prior to 6.3, the pass number is not reported in the header information (the pass number field does not exist) and so is not reported in the CGDR global attributes. For CMA versions 6.1 to 6.2_05 the relative orbit number reported in the header (and hence reported in the CGDR) is actually the pass number, and the relative orbit number is not reported in the product. For all versions of CMA prior to 9.0, the relative orbit number provided in the **filename** for ascending passes is the orbit number of the orbit at the start of the pass, rather than the orbit that starts at the ascending node crossing during the pass. However, the relative orbit number reported in the file **header** (from CMA 6.3 onwards) is the



expected value (ie the orbit number starting during the pass), ie that an ascending pass and the *following* descending pass have the same relative orbit number.

Table 3-3 IPF software version changes affecting SGDR products [AD 8; AD 9]

Version	Changes
IPF 4.56	-Extrapolation of AGC value to the Waveform centre (49.5) for both Ku- and S-band -Correction for an error found in the evaluation of S-band AGC
IPF 4.57	No impact on data
IPF 4.58	-Addition of a Pass Number Field in Fast Delivery Level 2 products
IPF 5.02	-MWR Side Lobe correction upgrade -USO clock period units correction -Rain Flag tuning to compensate for the increase of the S-band Sigma0 -Monthly IF mask taken into account -DORIS Navigator CFI upgrade (RA-2 and MWR) -S-band anomaly flag
IPF 5.03	-Correction for an error found in the Channel 2 brightness temperature -Correction for an error in the window delay (for the 80 and 20 MHz bandwidths) -S-band anomaly flag upgrade, now properly implemented -Correction of Rx-Fine parameter -MWR second channel corrected (Side Lobes correction)
IPF 5.06	None
IPF 6.02	New S-band Waveform Reconstruction Algorithm on RA-2 Level 1B Data New USO Correction Algorithm on RA-2 Level 1B Data

Table 3-4 CMA software version changes affecting SGDR products [AD 8; AD 9]

Version	Changes
CMA 6.1	<ul style="list-style-type: none"> -MSS CLS01 -Rain flag -MWR neural algorithm -Sea Ice tuning -Sea State Bias Table file -GOT00.2 Ocean Tide Sol 1 Map file -FES 2002 Ocean Tide Sol 2 Map file -FES 2002 Tidal Loading Coeff Map
CMA 6.2	No impacts on Envisat products
CMA 6.3	<ul style="list-style-type: none"> -Updated OCOG retracking thresholds Ice1 Conf file -Increased GDR data coverage by the use of both consolidated and non-consolidated data prods in inputs. - Addition of PASS_NO header item
CMA 7.1	<ul style="list-style-type: none"> -Improving the mispointing estimation -Addition of square of the SWH in Ku and S-band -Addition of GOT2000.2 loading tide -FES2004 tide and loading tide -New DEM AUX file (MACCESS) merge of ACE land elevation data and Smith and Sandwell ocean bathymetry -New orbit standards -New SSB solution -new wind table -MOG2D upgraded -New S1S2 wave model in dry troposphere -GOT00.2 includes two extra waves, S1 and S2 -GIM model ionospheric correction added in the products
CMA 8	-No impacts
CMA 9	-Correction of an anomaly in the relative orbit field in the file name. No scientific impact.
CMA 9.1	-Separating the processing of Jason-1 and Envisat No scientific impact.
CMA 9.2	<ul style="list-style-type: none"> -New POD orbit configuration. -New Dynamic Atmospheric Correction (DAC/MOG2D High Resolution)
CMA 9.3	<ul style="list-style-type: none"> -Updated Rain Flag Algorithm -New Sea-Ice Flag Algorithm



3.3 COASTALT: Envisat data in the coastal zone

The primary aim of the COASTALT project is to make the status of pulse-limited coastal altimetry operational, by defining and testing a new Envisat coastal radar altimeter product that ESA can routinely generate and distribute.

In order to achieve these aims, the project has developed a coastal processor that can:

- ingest the ESA Envisat level-2 SGDR products.
- reprocess the waveform data, using a number of alternative retracers to generate high resolution (18 Hz) data which may be more useful in coastal areas.
- generate new geophysical corrections from these new data.
- generate higher data rate geophysical correction data, by interpolation, as necessary for correcting the higher rate range data.
- output all the relevant original and new fields into a single file per pass, in a self-describing format.

The basic coastal product includes fields that can be determined for any coastal region, using the data from the altimeter itself, or instruments mounted on the same platform, and global models. This product does not include fields that would require specific auxiliary information, such as a region-specific tidal model, or *in situ* observational data. The current version, v2.0 [AD 7], of the product allows the generation of a USO correction field, using auxiliary data files provided by ESA along-side the SGDR data. The processor also uses auxiliary data files, provided by ESA, to allow correct calibration of the backscatter values from the processor. If any of the necessary auxiliary files are absent during the processing, then the relevant fields will be unfilled and the calibrations not applied. Additional fields may be added to the product, using the standalone product enhancer (*addcorr*).

The output product has been designed to allow use of the new, retracked, range, significant wave height and backscatter values, together with the geophysical corrections that rely on them (such as ionospheric correction and sea-state bias corrections). They also contain the comparable original data, to enable users to readily compare the SGDR and COASTALT values. One enhancement of the source data is to provide geophysical correction fields at the higher (18 Hz) data rate. This involves interpolation of the existing 1 Hz values. All geophysical corrections provided on the SGDR have been interpolated, using a simple linear interpolation, to provide 18 Hz correction values in the v2.0 CGDR products.

3.3.1 The COASTALT Processor

The COASTALT Processor is designed to be able to be used by experienced investigators to generate their own products, specific to their area of interest. To this end, the processor has been designed to be flexible in its use [AD 16]. Many of the parameters are defined by configuration files accessed at run-time, which can be tailored to specific requirements. In addition, the processor has a 'plug and play' capability [AD 17], allowing a user to implement their own re-tracking software, outputting the resultant retracking parameters as well as the fields of the basic product.

The output product can be restricted to include only data falling within a pre-defined coastal region. This is achieved by use of a coastal mask file, defined in the configuration file when the product is generated. The name of the coastal mask used is stored as a global attribute within the file (see §7.2). The coastal masks used in standard CGDR data have been generated using the coastal mask tool provided with the processor [AD 18].

3.4 Models used

The CGDR products are based on the Envisat Level 2 SGDR products. The input SGDR values have not been altered during translation to the CGDR product, except in the case of some flags (detailed below) and the generation of interpolated values. All algorithm specifications for variables determined directly from the SGDR values can be found in the Envisat documentation [AD 1].

Note: As the Envisat Level 2 products have not been generated with a single, consistent version of the level 1b IPF processing chain, nor a single version of the level 2 CMA processing chain (see §3.2), there are changes in input data format and content that have not been corrected in the output CGDRs.

The table below summarizes the models and standards that are adopted in this version of the CGDR. Section 3.5 provides more details on models added in the COASTALT processor, whilst more general information on included models is provided in §5.

Table 3-5 Models and standards

Parameter	Model
Orbit	Based on DORIS and laser tracking data. Specific model dependant on software processing version.
Altimeter Retracking	<p>“Ocean” retracking (from SGDR)</p> <p>Brown model as defined in [AD 1]</p> <p>COASTALT Brown retracking</p> <p>A Brown theoretical Ocean Retracker (BOR) [AD 6] – a modified version of [RD 20]</p> <p>COASTALT Specular retracking</p> <p>A Specular Beta-parameter Retracker (SBR) [AD 6]</p> <p>COASTALT Mixed retracking</p> <p>A Mixed Brown and Specular Retracker (MBS) [AD 6]</p>
Altimeter Instrument Corrections	Consistent with “Ocean” retracking algorithm [AD 1]
USO Correction	From an instrumental method based on the comparison between the USO clock and an external clock: the platform clock [RD 11]
Dry Troposphere Range Correction	From ECMWF atmospheric pressures and model for S1 and S2 atmospheric tides
Wet Troposphere Range Correction from Model	From ECMWF model
Wet Tropospheric Correction from Radiometer	Obtained with a neural algorithm from the 23.8 GHz and 36.5 GHz brightness temperatures (in K) interpolated to RA-2 time tag, and the ocean backscatter coefficient for Ku-band (dB), not corrected for atmospheric attenuation [RD 24]
Wet Tropospheric Correction from Dynamic Linear Model	Obtained using the DLM algorithm, an interpolation based primarily on the radiometer wet tropospheric correction (see §3.5.2)
Ionospheric Correction	<p>from the dual frequency Ocean re-tracked range measurements (until S-band failure on 18 Jan 2008)</p> <p>from the DORIS daily maps of Total Electron Content</p> <p>from the GIM model for products processed with CMA v7.1 or higher</p> <p>The following are only available until S-band failure on 18 Jan 2008:</p> <p>from the COASTALT Brown retracked dual frequency ranges (until S-</p>



Parameter	Model
	band failure on 18 Jan 2008) from the COASTALT Specular retracked dual frequency ranges (until S-band failure on 18 Jan 2008) from the COASTALT Mixed retracked dual frequency ranges (until S-band failure on 18 Jan 2008)
Sea State Bias	empirical function of Ku-band's significant wave height and the RA-2 wind speed, derived from one year of Envisat data (cycles 25 to 35), using crossover SSH differences and applying the non parametric estimation technique [RD 18]
Inverse Barometer Correction	Computed from ECMWF atmospheric pressures after removing S1 and S2 atmospheric tides
Non-tidal High-frequency Dealiasing Correction	Mog2D High Resolution ocean model. Ocean model forced by ECMWF winds and atmospheric pressures after removing S1 and S2 atmospheric tides – difference of this value and the inverse barometer correction is reported [RD 6]
Tide Solution 1	GOT00.2b – total geocentric tide [RD 7, RD 33], including the load tide and the long-period equilibrium tide contributions
Tide Solution 2	FES2004 – total geocentric tide [RD 25], including the load tide [RD 16] and the long-period equilibrium tide contributions
Solid Earth Tide Model	From Cartwright and Taylor tidal potential [RD 8]
Pole Tide Model	Equilibrium model [RD 43]
Wind Speed from Model	ECMWF model 10 m u and v wind components
Altimeter Wind Speed Model	Algorithm based on a fit between Envisat Ku-band Sigma0 and the collocated ECMWF model wind speed, adjusted based on in-situ wind measurements [RD 1].
Rain Flag	If the expected Ku/S-band rain-free relationship minus the uncorrected Ku ocean backscattering coefficient, and if the MWR liquid water content are bigger than certain thresholds
Mean Sea Surface	CLS01 [RD 22]
Mean Dynamic Topography	CLS Rio 05 [RD 35]
Geoid	EGM96 [RD 28]
Bathymetry Model	MACCESS Global Digital Elevation Model [RD 13]

3.5 COASTALT Specific Models

3.5.1 COASTALT retrackers

Three physically based waveform retrackers are implemented and run in parallel in the COASTALT processor in its standard configuration. They are:

- a conventional Brown theoretical Ocean Retracker
- a Specular Beta-parameter retracker with Exponential trailing edge
- an experimental Mixed Brown Specular retracker

3.5.1.1 Retracker 1: Brown theoretical ocean retracker (BOR)

This is an implementation of the well-known Brown ocean waveform retracker, known to perform well for altimeter waveforms over the open ocean and (typically) up to ~10 km from the coast.

The complete expression of the power $P_r(t)$ at time t is given by:

$$P_r(t) = \frac{const1 * sigma0}{h^3} \exp \left\{ -\frac{4}{\varphi} \sin^2 \xi - \frac{4c}{\varphi h} (t - t_0) \cos 2\xi \right\} I_0 \left(\frac{4}{\varphi} \sqrt{\frac{c(t-t_0)}{h}} \sin 2\xi \right) \quad Eq. 1$$

$$\left\{ erfc \left(\frac{-(t-t_0)}{\sqrt{2}\sigma_c} \right) - \frac{1}{\sqrt{2\pi}} \exp \left(\frac{-(t-t_0)^2}{2\sigma_c^2} \right) \frac{\lambda SWH^3}{24c^3 \sigma_c^3} He_2 \left(\frac{(t-t_0)}{\sigma_c} \right) \right\} + Tn \quad \text{for } t \geq t_0$$

And

$$P_r(t) = \frac{const1 * sigma0}{h^3} \exp \left\{ -\frac{4}{\varphi} \sin^2 \xi \right\} \quad Eq. 2$$

$$\left\{ erfc \left(\frac{-(t-t_0)}{\sqrt{2}\sigma_c} \right) - \frac{1}{\sqrt{2\pi}} \exp \left(\frac{-(t-t_0)^2}{2\sigma_c^2} \right) \frac{\lambda SWH^3}{24c^3 \sigma_c^3} He_2 \left(\frac{(t-t_0)}{\sigma_c} \right) \right\} + Tn \quad \text{for } t < t_0$$

with

- σ_0 the normalised radar backscatter cross-section at nadir
- h the satellite height
- ξ the mispointing angle (from nadir)
- c the velocity of light in vacuo
- t_0 the time origin ($=2h/c$) corresponding to the mid-point on the waveform leading edge
- $I_0(t)$ the modified Bessel function of the first kind [RD 2]
- Tn the thermal noise
- $erfc(x)$ the complementary error function [RD 2]
- λ the ocean skewness
- SWH the Significant Wave Height
- He_2 the Hermite polynomial of order 2



and

$$const1 = \frac{G_0^2 \lambda_R^2 c \eta P_T \sigma_p}{4(4\pi)^2 l_p} \sqrt{\frac{\pi}{2}} \quad \text{Eq. 3}$$

$$\varphi = \frac{\Psi_B^2}{2 \ln 2} \quad \text{Eq. 4}$$

$$\sigma_c = \sqrt{\sigma_p^2 + \frac{4\sigma_s^2}{c^2}} \quad \text{Eq. 5}$$

with

- G_0 the antenna gain parameter
- λ_R the radar wavelength
- η the pulse compression ratio
- P_T the transmitted power
- $\sigma_p = 0.53 \times (\text{compressed pulse width})$ [AD 2]
- l_p the two-way propagation loss over and above the free-space loss
- Ψ_B the antenna beam in radians
- σ_s the standard deviation of the sea surface elevation, related to the significant wave height by $\sigma_s \sim SWH/4$.

These are the equations implemented in the NOC-S BOR retracker, which has been used successfully to retrack Envisat RA-2 Ku-band waveforms [RD 20].

In the first instance, the implementation of the NOC-S BOR retracker in the COASTALT processor will make the following simplifications:

- four parameters retrieval: range (t_0), SWH (σ_s), Sigma_0 , Thermal Noise
- Linear wave statistics (skewness and cross-skewness set to zero)
- Least-square fitting (with provision for weighted least square fitting in future)

3.5.1.2 Retracker 2: Specular Beta-parameter retracker (SBE)

This waveform model is the Specular Beta-parameter retracker with exponential trailing edge, as outlined in Deng & Featherstone [RD 12]. This functional form is well suited to fit waveforms with a rapidly decaying trailing edge. The algorithm fits a 5- or 9-parameter function to the waveform reflected from one or two scattering surfaces.

The general function for the model is:

$$SBE(t) = \beta_1 + \sum_{i=1}^n \beta_{2i} \exp(-\beta_{5i} Q_i) P\left(\frac{t - \beta_{3i}}{\beta_{4i}}\right) \quad \text{Eq. 6}$$

where

$$Q_i = \begin{cases} 0 & \text{for } t < \beta_{3i} - 2\beta_{4i} \\ t - (\beta_{3i} - 2\beta_{4i}) & \text{for } t \geq \beta_{3i} - 2\beta_{4i} \end{cases} \quad \text{Eq. 7}$$

(NB – equation corrected from Eq A10 in [RD 12]) and

$$P(x) = \int_{-\infty}^x \frac{1}{\sqrt{2\pi}} \exp\left(\frac{-q^2}{2}\right) dq \quad \text{Eq. 8}$$

and $n = 1$ or 2 is the number of the ramp in the waveform that corresponds to the single- or double-reflecting surfaces in the 5- and 9-parameter form respectively.

In the COASTALT processor, the 5-parameter form of the retracker has been implemented, with provision for a future implementation of the 9-parameter form.

The waveform fitting has been performed using ordinary least squares, with provision made for weighted least square in future.

3.5.1.3 Retracker 3: Mixed Brown Specular retracker (MBS)

The functional form of this retracker consists of the linear superposition of the Brown model (Eq. 1-2) and the 5-parameter Specular Beta-parameter model (Eq. 6), i.e.

$$MBS(t) = BOR(t) - SBE(t) \quad \text{Eq. 9}$$

This is an experimental retracker which aims to address the retracking of coastal waveforms, which display a specular peak embedded within a Brown-type ocean waveform. Such highly variable waveform shapes are frequently observed during the analysis of waveforms in the coastal zone in WP3.1 (*e.g.* see Figure 4).

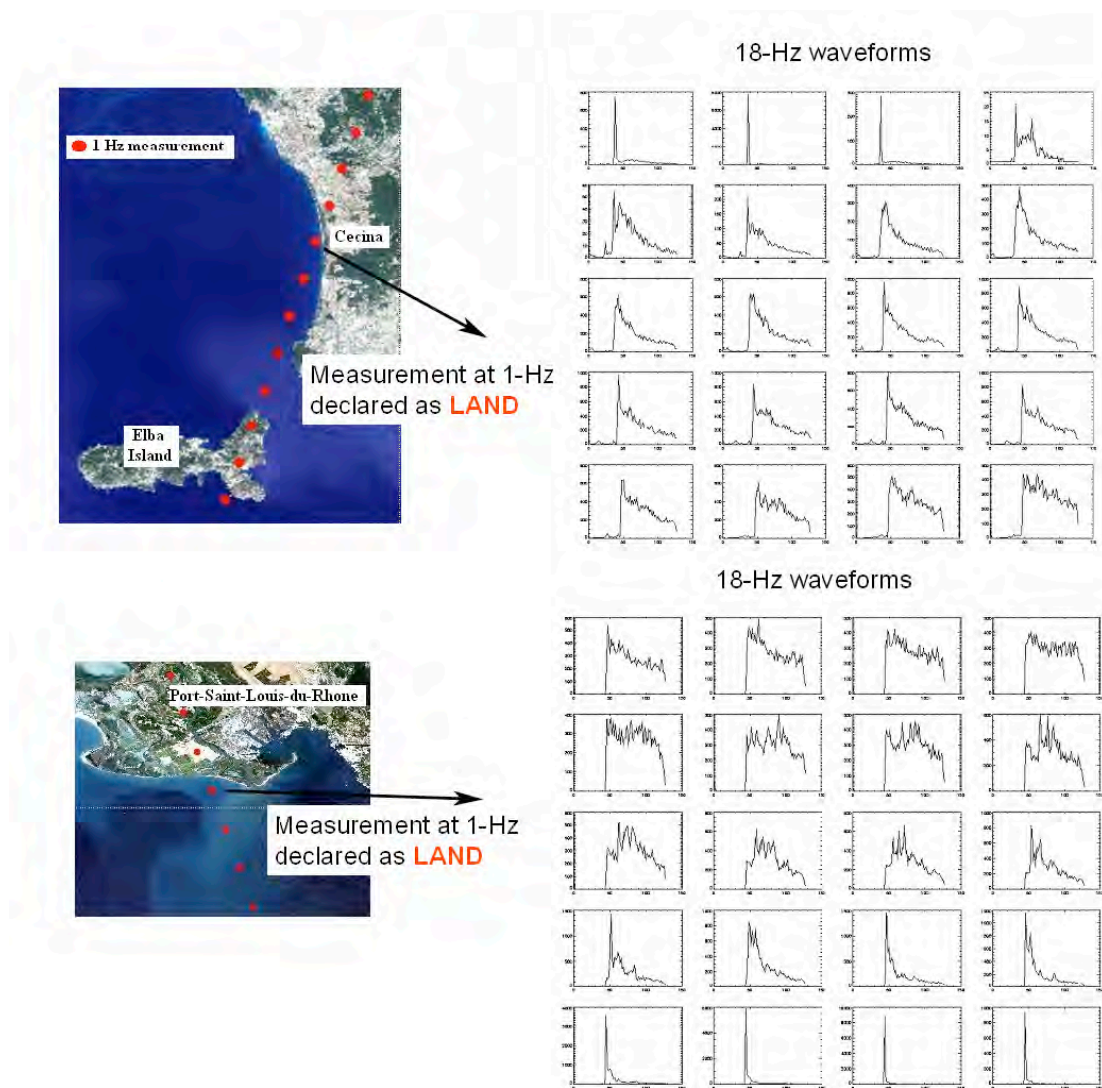

Figure 4: Examples of 18Hz Ku-band waveforms in the coastal zone in the North-West Mediterranean test site (from AD 11)

3.5.2 Wet Tropospheric Correction from Dynamically Linked Model

The wet tropospheric correction is calculated using the Dynamically Linked Model approach. The method is described in detail in AD 10. It is based on the radiometer-derived wet tropospheric correction; with 'gaps' filled using calibrated atmospheric model derived correction. In the case of the CGDR data, the source for the model correction is the ECMWF model.

There are two cases to be considered depending on the length of the coastal data segment over which radiometer wet trop correction is missing or bad:

3.5.2.1 "Long" (>60km) radiometric wet tropospheric correction gap

This is the typical case when the satellite is approaching or receding from a large land-mass, as illustrated in Figure 5.

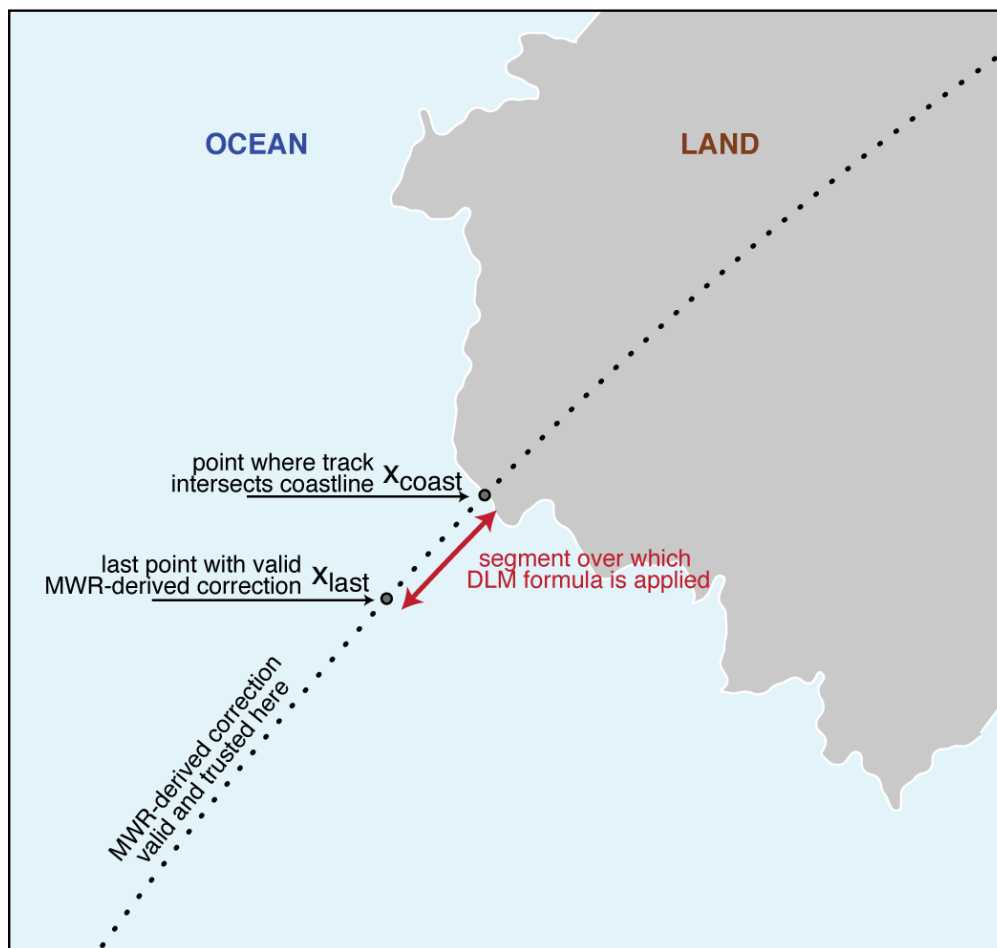

Figure 5: Typical configuration for a "long" radiometric wet tropospheric correction gap

In this case, the bias in the model correction with respect to the observed radiometer-derived correction is calculated at the last point with valid radiometer data as:

$$\text{bias} = R_{\text{MOD}}(x_{\text{last}}) - R_{\text{MWR}}(x_{\text{last}}) \quad \text{Eq. 10}$$

and the new model wet trop correction up to the coastline x_{coast} reads:

$$R_{\text{wettropo}}(x) = R_{\text{MOD}}(x) - \text{bias} \quad \text{for } x = x_{\text{last}} \text{ to } x_{\text{coast}} \quad \text{Eq. 11}$$

3.5.2.2 “Short” (<60km) or “ocean-only” wet tropospheric correction gap

This is the more complex case where the gap with missing or bad radiometer wet tropospheric correction is less than 60 km, or the radiometer data is contaminated by land located across-track from the nadir. Both examples are illustrated in Figure 6.



Figure 6: Configuration for short (less than 60km) radiometer data gap or contamination by land located across-track from nadir.

In both cases, the bias between the model wet tropospheric correction and the radiometer wet tropospheric correction is calculated from the last valid radiometer data point on both sides of the gap, i.e.

$$bias1 = R_{MOD}(X_{last1}) - R_{MWR}(X_{last1}) \quad \text{Eq. 12}$$

$$bias2 = R_{MOD}(X_{last2}) - R_{MWR}(X_{last2}) \quad \text{Eq. 13}$$

and the new model correction becomes:

$$R_{wettropo}(x) = R_{MOD}(x) - [(1-\alpha) \cdot bias1 + \alpha \cdot bias2] \quad \text{Eq. 14}$$

where

$$\alpha = (x - X_{last1}) / (X_{last2} - X_{last1}) \quad \text{Eq. 15}$$

represents the linear variation of the correction from *bias1* at X_{last1} to *bias2* at X_{last2} .

3.5.2.3 Use of the DLM in the CGDR

In the CGDR, the dynamically linked model is used to generate the 18 Hz radiometer wet tropospheric correction (hz18_mwr_wet_trop). The radiometer interpolation flag (mwr_wet_trop_interp_flag) can be used to determine the source of the correction value. The DLM correction is determined initially at 1 Hz using the SGDR supplied 1 Hz model and MWR derived wet tropospheric corrections. Where the MWR derived value is flagged as good (the Measurement Confidence Data flag, meas_conf_data_flags, bits 8-12 and the radiometer land flag, radio_landocean_flag, all set zero) the 1 Hz DLM correction value is set equal to the MWR correction value and the MWR interpolation flag value is set to 0. Gaps in the 1 Hz values are then filled using the DLM, as described above. Where the DLM has interpolated over a short gap, the interpolation flag is set to 1. Where the DLM has been used to interpolate a long gap, the interpolation flag is set to 2. Where no interpolation has been possible the 1 Hz DLM value is left default and the interpolation flag is set to 3.

This 1 Hz DLM value is then interpolated to the 18 Hz times using the same, simple linear interpolation scheme as used for the other 18 Hz correction values.

3.5.3 Distance from coast

In the COASTALT CGDR products, the distance from coast is computed at 18 Hz by linear 2-d interpolation of a distance map onto the locations of the 18 Hz points. Since version 2.0.2 of the CGDR the distance map has been computed using the GSHHS (Global Self-consistent, Hierarchical, High-resolution Shoreline) high-resolution shoreline data set, amalgamated from two databases (the CIA world database WDBII, and the World Vector Shoreline database) and maintained by P. Wessell and W. H. F. Smith [RD 44].

The algorithm used is an approximation, and for each gridpoint in the distance map, is derived by:

- 1) determining the distance of the gridpoint from its projection onto each side of each polygon in the GSHHS database (within a limited region for speed of calculation)
- 2) determining the distance of the gridpoint from all the vertices of each polygon
- 3) selecting the shortest distance calculated.

Distances are computed in degrees, in the cartesian plane (neglecting curvature), and then converted into km using a fixed conversion factor of 111 km/degree (hence the approximation), which is only acceptable for short lengths (<200 km) and at low-to-mid latitudes (<60°).



4 Using the CGDR data

4.1 Overview

This section will give the reader a guide to the use of the CGDR data. These products are experimental, and provided primarily for research purposes. They have not yet been fully validated, and users should proceed with caution, particularly in regard to the coastal specific fields. While this handbook tries to be correct and complete, note that nothing can replace the information to be gained at conferences and other meetings from those using these data.

The reader must proceed with caution and at his or her own risk.

The instruments on Envisat make direct observations of the following quantities of interest to satellite altimetry users: altimeter range, ocean significant wave height, ocean radar backscatter cross-section (primarily a function of surface wind speed), ionospheric electron content in the nadir direction and tropospheric water content. Ground based laser station and DORIS station measurements of the satellite location and speeds are used in precision orbit determination (POD). The DORIS stations also measure the ionospheric electron content along the line of sight to the satellite. All of these measurements are useful in themselves, but they are made primarily to derive the sea surface height with the highest possible accuracy. Such a computation also needs external data (not collected aboard Envisat), e.g., atmospheric pressure. In addition, instrument health and calibration data are collected onboard and used to make corrections to the main measurements and to monitor the instrument stability in the long term.

This CGDR contains all relevant corrections needed to calculate the sea surface height. For the other geophysical variables in the CGDR: ocean significant wave height, tropospheric water content, ionospheric electron content (derived by a simple formula) and wind speed, the necessary instrument and atmospheric corrections have already been applied.

The following sections explain the organisation of the products, and the rationale for how the corrections should be applied.

4.2 Organisation of the Product

The CGDR products are arranged as one file per pass, as for the source SGDR products.

The product names are based on the convention used for the Envisat Level 2 Products, namely:

Filename = <product_ID><processing_stage_flag><originator_ID>
<start_day>_<start_time>_<duration>
<phase><cycle>_<relative_orbit>_<absolute_orbit>_<counter>.nc

With:

<product_ID>	RA2_MWS_2P	
<processing_stage_flag>	0	Processing stage flag (N-V, where letter closer to V are higher levels of consolidation)
<originator_ID>	F-P	A 3 character ID code for the originator of the Level 2 products (F-P is the French PAF, AVISO)
<start_day>	yyyymmdd	UTC date of first record in file in year month day order
<start_time>	Hhmmss	UTC time of first record in file in hour minute second format
<duration>	Sssssss	duration of product in seconds
<phase>	A	mission phase – single character A or B
<cycle>	CCC	the cycle, a three digit number, eg 021 = cycle 21
<relative_orbit>	XXXXX	the relative orbit number within the cycle, a five digit number from 00001 to 00501, eg 00042 is relative orbit 42
<absolute_orbit>	XXXXX	the absolute orbit number since the start of the mission, a five digit number, eg 02456
<counter>	XXXX	incremental counter for product, from 0000 to 9999 then wraps to 0000

For example:

Product:

RA2_MWS_2POF-P20040408_201943_00003017A025_00443_11018_0391.nc

is based on the SGDR product:

RA2_MWS_2POF-P20040408_201943_00003017A025_00443_11018_0391.N1

Which is a level 2 RA2 / MWR product, at processing stage 0, originating from the French PAF, with the first record in the file from 8th April 2004, 20:19:43, including 3017 seconds of data from phase A, cycle 25, relative orbit 443, absolute orbit 11018 and was product 391 generated (in base 10000).

Note 1 – the data for a single orbit (south pole to south pole) will be contained in two separate files. The two files will have the same <phase>, <cycle>, <relative_orbit> and <absolute_orbit>.

Note 2 – due to changes in the software generation, the <relative_orbit> and <absolute_orbit> in the product filename are not consistently applied. For cycles 0 – 57 the ascending pass



(from southern extreme to northern extreme) of each orbit was assigned a filename with the <relative_orbit> corresponding to the orbit at the *start* of the pass, not the orbit that starts during the pass. From cycle 58, the <relative_orbit> assigned to the pass was the orbit that starts at the equator crossing of the pass, as this assigns passes 1 and 2 to orbit 1, which is more intuitive and consistent with numbering used for other altimetry mission. For consistency with the source data, the CGDR products use the *same* filename as the source SGDR products and hence have the same inconsistency in file naming.

Users are advised to check the global attributes of the CGDR files to ensure they have the correct pass (see §3.2 for more details).

The CGDR product is arranged with related values clustered together in the product. Hence, the first section of the product contains the dimension variables and coordinate variables then the orbit information (including the positional information). The complete list of variables included in the products is given in AD 7.

Within each section, there will be variables reported at “1 Hz” and variables reported at 18 Hz. The “1 Hz” variables (actually, 0.9 Hz) represent an average of 20 of the 18 Hz values. The 18 Hz variables are represented as 2 dimensional variables, with the primary dimension equal to the dimension of the 1 Hz data, and the second dimension being 20 – the number of samples in the 1 Hz average. The 1 Hz average is calculated as occurring at the centre- point of the 18 Hz values, ie between the location of the 10th and 11th 18 Hz values.

In general the 1 Hz and 18 Hz variables will have the same variable name, with the 18 Hz versions having the variable name prefixed by **hz18_**, eg the primary coordinate variables are **lat** and **lon**, whilst the coordinate variables associated with the 18 Hz values are **hz18_lat** and **hz18_lon**.

Within each section, if a Ku-band value and an S-band derived value are reported, the S-band value will immediately follow the corresponding Ku-band value

4.3 Typical computation from altimetry data

In this section references are made to specific CGDR parameters by name using the name of the variable as described in the netCDF data sets. These names were initially defined by the parameter descriptions from the Envisat Level-2 product definition documents, for ease of referencing of the source algorithms. Some minor modification has occurred for internal consistency within the product.

WARNING: Default values, provided in the `_FillValue` attribute, are given to data when computed values are not available, **the user must screen parameters to avoid using those with default values**. Also the user must check flag values. The related flags are given in the description of each variable (see §7.1.1.4) although some discussion of flags appears in this section.

In all cases – the user must ensure that all values are available at the same frequency. 1 Hz version of 18 Hz values can be calculated by averaging over the 20 samples. 18 Hz data can be generated by interpolating the 1 Hz values, using time as the interpolation base variable and remembering that the 1 Hz average represents the centre of the associated 18 Hz measurements (between the 10th and 11th points). All SGDR corrections available on the CGDR have also been interpolated to 18 Hz for ease of use of the data.

4.3.1 Corrected Altimeter Range

The main data of the CGDR are the altimeter ranges. The CGDR provides ranges measured at Ku-band (range_ku) and S-band (range_s). The Ku-band range is used for most applications. The given ranges are corrected for instrumental effects (not including the correction for the USO clock error). These corrections are separately reported for each of the Ku and S-band ranges (net_instr_corr_range_ku and net_instr_corr_range_c).

The given ranges must be corrected by the user for path delay in the atmosphere through which the radar pulse passes, the nature of the reflecting sea surface and errors in the USO clock timing. All range corrections are defined and they should be **ADDED** to the range. A corrected (Ku-band) range is given by:

Corrected Range =	Range + Wet Troposphere Correction + Dry Troposphere Correction + Ionosphere Correction + Sea State Bias Correction + USO Correction
-------------------	---

4.3.1.1 Range:

This may be one of the SGDR range values, or one of the COASTALT retracked ranges, as given in Table 4-1.

Table 4-1 Available range values in the CGDR

1 Hz range value	18 Hz range value	source
	hz18_[ku/s]_trk_cog	the onboard tracker value (not recommended)
[ku/s]_band_ocean_range	hz18_[ku/s]_band_ocean	SGDR Ocean retracker
	brown_range_[ku/s]	COASTALT Brown retracker
	specular_range_[ku/s]	COASTALT Specular retracker
	mixed_range_[ku/s]	COASTALT mixed retracker

The COASTALT Brown retracker output gives ranges very similar to the SGDR retracker, although there will be some differences, most markedly in the coastal areas.

The ranges from the specular and mixed retracker have not yet been validated and should be used with caution. In open ocean conditions, the mixed retracker is expected to produce very similar results to the Brown retracker, but this may not be the case, particularly in areas with very smooth water surfaces (very low wind conditions).

Note: it is not recommended that users change range source within a single analysis, as there may be unknown biases between the retracker ranges.



4.3.1.2 Wet Troposphere Correction

Table 4-2 Available wet tropospheric correction values in all CGDR products

1 Hz correction	18 Hz correction	source
mod_wet_tropo_corr	hz18_mod_wet_tropo_corr	ECMWF Model
mwr_wet_tropo_corr		MWR
	hz18_mwr_wet trop	Dynamically Linked Model

The model wet tropospheric correction will exist for all 1 Hz measurements, but the MWR measurement is expected to more accurately capture short-scale tropospheric processes affecting the water vapour concentration. The Dynamically Linked Model is designed to allow the MWR correction to be used closer to the coast, where the radiometer data become corrupted by land in the footprint (see §3.5.2). If the user wishes a ‘pure’ MWR 18 Hz correction, then use of hz18_mwr_wet_trop when the associated flag (mwr_wet_trop_interp_flag) is equal to zero will provide only MWR derived values, with the quality control already applied.

For some limited regions, enhanced CGDR products may be available, that contain an additional wet tropospheric correction, at 18 hz, generated using the novel GPD algorithm [AD 13, AD 14, AD 15, RD 15]. The GPD correction has been generated at 1 Hz by University of Porto, then interpolated to 18 Hz, using simple linear interpolation, before addition to the CGDR products.

Table 4-3 Additional wet tropospheric correction values in a limited number of enhanced CGDR products

1 Hz correction	18 Hz correction	source
	hz18_GPD_wet_tropo_corr	GPD algorithm [AD 15, RD 15]

Note: the GPD wet tropospheric correction, and its associated flag, error and variance (see Table 7-4), are not part of the COASTALT ‘baseline’ CGDRs but are added to some versions of the CGDRs by use of the standalone product enhancer (*addcorr*). The user should check for presence of these variables in their products.

4.3.1.3 Dry Troposphere Correction

Only one dry tropospheric correction is provided: the ECMWF model correction at 1 Hz (mod_dry_tropo_corr), together with the correction interpolated to 18 Hz (hz18_mod_dry_top_corr).

4.3.1.4 Ionosphere Correction

There are a number of ionospheric corrections available on the CGDR, given in Table 4-4. The DORIS and model corrections are available for both the Ku and S-band ranges. The other corrections, determined from the Ku and S-band ranges given by a particular retracker, apply only to the Ku-band and should be used with their respective ranges.

Table 4-4 Available ionospheric correction values in the CGDR

1 Hz correction	18 Hz correction	source
ion_corr_doris_[ku/s]	hz18_ion_corr_doris_[ku/s]	DORIS ionospheric measurements
ion_corr_mod_[ku/s]	hz18_ion_corr_mod_[ku/s]	GIM ionospheric model (from CMA 7.1 onwards)
ra2_ion_corr_ku	hz18_ra2_ion_corr_ku	Dual frequency ranges from Ocean retracker
	iono_corr_brown_ku	Dual frequency ranges from COASTALT Brown retracker
	iono_corr_spec_ku	Dual frequency ranges from COASTALT Specular retracker
	iono_corr_mixed_ku	Dual frequency ranges from COASTALT Mixed retracker

IMPORTANT: See Section 4.3.5 "Smoothing the Ionosphere Correction".

NOTE: as the S-band ceased operation on 18 January 2008 (cycle 65), all dual frequency ionospheric correction values after this date will be set to the default value

4.3.1.5 Sea State Bias Correction

The sea state bias correction, determined from the SGDR Ocean retracker ranges, wave heights and wind speeds, is available for both Ku and S-band, and also at both 1 Hz (sea_bias_ku, sea_bias_s) and 18 Hz (hz18_sea_bias_ku, hz18_sea_bias_s). Use the appropriate sea state bias correction, to correct the Ku and S-band ranges. As this correction is determined empirically, it is probable that the table used to determine the relationship of wave height and wind speed to sea state bias correction will be different for the different retrackerers. However, this has not yet been determined.



4.3.2 Sea Surface Height and Sea Level Anomaly

Sea surface height (SSH) is the height of the sea surface above the reference ellipsoid. It is calculated by subtracting the corrected range from the altitude:

$$\text{Sea Surface Height} = \text{Altitude} - \text{Corrected Range}$$

For most oceanographic purposes, the effects of non-geostrophic processes on the sea surface height will also be removed using geophysical corrections.

Note: all the geophysical parameters here are *heights*, as defined in §1.4.1.1, and as such are positive *upwards*.

$$\begin{aligned} \text{Corrected Sea Surface Height} = & \text{Altitude} \\ & - \text{Corrected Range} \\ & - \text{Solid Earth Tide Height} \\ & - \text{Geocentric Ocean Tide Height} \\ & - \text{Pole Tide Height} \\ & - \text{Inverted Barometer Height Correction} \\ & - \text{HF fluctuations of the Sea Surface} \end{aligned}$$

Note: for coastal applications, where comparison with tide gauges or other measurement systems is to be undertaken, not all the geophysical corrections may need to be applied. In particular, the inverted barometer correction may be omitted.

The sea level anomaly (SLA), also referred to as Sea Surface Height Anomaly, is defined here as the sea surface height minus the mean sea surface. It is given by:

$$\text{Sea Level Anomaly} = \text{Corrected Sea Surface Height} - \text{Mean Sea Surface}$$

The SLA contains information about:

- Real changes in ocean topography related to ocean currents
- Differences between the true dynamic response to atmospheric pressure and the applied inverse barometer and model high frequency response.
- Differences between tides and the tide models
- Differences between the mean sea surface model and the true mean sea surface at the altimeter location
- Un-modelled or mis-modelled measurement effects (skewness, sea state bias, altimeter errors, tropospheric corrections, ionospheric correction, etc.)
- Orbit errors

There is naturally also random measurement noise.

4.3.2.1 Altitude

The orbit altitude (see parameter altitude in §1.4.1.1). This is available at 1 Hz (alt_cog_ellip) and 18 Hz (hz18_alt_cog_ellip).

4.3.2.2 Corrected Range

See section 4.3.1.

4.3.2.3 Tide Effects

The total tide effect on the sea surface height is the sum of three values from the CGDR:

$$\text{Tide Effect} = \text{Geocentric Ocean Tide} + \text{Solid Earth Tide} + \text{Pole Tide}$$

(See also section 5.7 and subsections)

Geocentric Ocean Tide

The geocentric ocean tide provided on the CGDR is the sum total of the ocean tide, with respect to the ocean bottom, and the loading tide height of the ocean bottom.

$$\text{Geocentric Ocean Tide} = \text{Ocean Tide} + \text{Load Tide}$$

The CGDR provides a choice of two geocentric ocean tide values, each also available interpolated to 18 Hz (see Table 4-5). Each uses a different model for the sum total of the ocean tide and loading tide heights from the diurnal and semidiurnal tides, but both include an equilibrium representation of the long-period ocean tides at all periods except for the zero frequency (permanent tide) term.

Note: the CGDR also explicitly provides the loading tide height from each of the two models that are used to determine the two geocentric ocean tide values, at 1 Hz (tidal_load_ht_sol1, tidal_load_ht_sol2) and interpolated to 18 Hz (Hz18_tidal_load_ht_sol1, Hz18_tidal_load_ht_sol2). Obviously, the geocentric ocean tide values and loading tide values **should not** be used simultaneously, since the loading tide height would be included twice.

Table 4-5 Available ocean tide correction values in the CGDR

1 Hz correction	18 Hz correction	source
tot_geocen_ocn_tide_ht_sol1	hz18_tot_geocen_ocn_tide_ht_sol1	GOT00.2b
tot_geocen_ocn_tide_ht_sol2	hz18_tot_geocen_ocn_tide_ht_sol2	FES2004

Solid Earth Tide

A single solution, at 1 Hz (solid_earth_tide_ht) and interpolated to 18 Hz (hz18_solid_earth_tide_ht), is provided.

NOTE: Zero frequency (permanent tide) term also not included in this parameter.

Pole Tide

A single solution, at 1 Hz (geocen_pole_tide_ht) and interpolated to 18 Hz (hz18_geocen_pole_tide_ht), is provided.



4.3.2.4 Surface Air Pressure Effects

The effect of the surface air pressure is split into two – the inverse barometer, or the direct response of the ocean to atmospheric pressure, and the high frequency response of the ocean to changes in the atmospheric pressure. Both terms are included on the CGDR.

Inverted Barometer Height Correction

A single solution, at 1 Hz (`inv_barom_corr`) and interpolated to 18 Hz (`hz18_inv_barom_corr`), is provided (see also §5.8).

HF Fluctuations of the Sea Surface

A single solution, at 1 Hz (`dib_hf`) and interpolated to 18 Hz (`hz18_dib_hf`), is provided (see also §5.8).

4.3.2.5 Geophysical Surface - Mean Sea Surface or Geoid

The geophysical fields Geoid (`geoid_ht`, `hz18_geoid_ht`) and Mean Sea Surface (`m_sea_surf_ht`, `hz18_m_sea_surf_ht`) are heights (*ie* distances above the reference ellipsoid), as is the Sea Surface Height. The quantity normally required for oceanography is the dynamic topography, or the height of the sea surface above the geoid (see §1.4.1.1). However, the properties of the geoid at high frequency are only known through inference from the mean sea surface, which approximates to the geoid. Hence, use of the geoid for determining dynamic topography is only appropriate for long-wavelength oceanographic features. Instead, it is more normal to reference to the mean sea surface, to determine the sea level anomaly.

See also discussions of mean sea surface and geoid in sections 5.2 and 5.3.

4.3.3 Data Editing Criteria

The following criteria are recommended in the Envisat level 2 product handbook [AD 2]. They strictly apply only to the values taken directly from the SGDR product.

User should review these criteria before using them and may wish to modify them!

First, check the following conditions to retain only ocean data and remove any bad, missing, or flagged data:

- operating mode set to RA-2 nominal tracking
- waveform quality flags set to OK (= 0)

Over the ocean, users are advised to edit the data according to Table 4-6.

For coastal application it will be necessary to relax some of these criteria – in particular regarding tide correction values and standard deviation of range.

Table 4-6 Recommended editing criteria

Min. Value	Parameters	Max. Value	Unit
-2	SSH – mean sea surface height	2	m
10	Number of 18 Hz valid points for Ku-band	20	
0	Range Standard deviation	0.25	m
-0.2	Off-Nadir angle square of the satellite from waveforms	0.16	deg ²
-2.5	Dry tropospheric correction	-1.9	m
-2	Inverse barometer correction	2	m
-0.5	Wet tropospheric correction	-0.001	m
-0.4	Ionospheric correction	-0.04	m
0	Significant wave height	11	m
-0.5	Sea State Bias	0	m
7	Backscatter coefficient	30	db
-5	Ocean tide correction	5	m
-0.5	Long period equilibrium	0.5	m
-1	Earth tide correction	1	m
5	Polar tide correction	5	m
0	Wind speed	30	m/s
0	S-band anomaly flag	0	

4.3.3.1 Use of Flags

A series of quality control flags are available on the CGDR products to assist in identifying missing, or poor quality data.

Some flags (see Table 4-7) provide general information on the quality, or potential quality, of the altimeter signal and processing. These flags may be used to identify the potential cause of poor data. The complex flags from the SGDR (meas_conf_data_flags, instr_flags, mwr_instr_flag and interpolate_flag) are further defined in Table 4-8, Table 4-9,

Table 4-10 and Table 4-11).



Table 4-7 General Quality Flags Available in the CGDR Products

Flag	dimension	Flag meaning
inst_mode_id_flags	Time	Instrument mode ID 16: acquisition 32:Tracking 33: Preset_Tracking 34: Preset_Loop_Output 48: IF_Cal 65: BITE_RF 67: BITE_DGT
meas_conf_data_flags	time	see Table 4-8
ave_ku_chirp	time	minimum of 18 hz chirp id values 0: at least one record at 320 MHz 1: at least one record at 80 MHz (others are at 20 MHz) 2: all input records are at 20 MHz
ku_chirp_id_flags	time,samples	0: 320 MHz 1: 80 MHz 2: 20 MHz Default values (bits set to 1) are output in the event of non tracking records (records not in Tracking, Preset Tracking or Preset Loop Output), wherever the sum of all Ku and S waveforms samples are set to 0, or if Ku AGC or Ku onboard Rx delay are out of bounds
error_flag_chirp_id_flags	time	Error flag for chirp band id 0: valid 1: invalid
instr_flags	time	see Table 4-9
instr_id_data_level_flags	time,samples	Instrument mode ID at data block level 0: spare 1: acquisition 2:Tracking 3: IF_Cal 4: BITE_RF 5: BITE_DGT 6: Preset_Tracking 7: Preset_Loop_Output 8: Alignment_failed
num_meas_ku_calibr	time	Number of Ku flight calibration factors (currently from 0 to 5) used at L1B to obtain the smoothed Sigma0 and time delay PTR flight calibration factors
num_meas_s_calibr	time	Number of S flight calibration factors (currently from 0 to 5) used at L1B to obtain the smoothed Sigma0 and time delay PTR flight calibration factors
mwr_instr_flag	time	see Table 4-10

Flag	dimension	Flag meaning
altim_landocean_flag	Time	Altimeter Surface type flag 0: oceans or semi-enclosed seas 1: enclosed seas or lakes 2: continental ice 3: land
radio_landocean_flag	time	Radiometer land/ocean flag 0: Ocean 1: Land, or radiometer not available
rain_flag	time	0: no rain 1: rain
interpole_flag	time	see Table 4-11

Table 4-8 Definition of variable meas_conf_data_flags

Bit Nos	Description	Values
28-31	Orbital processing status	0011 : Adjusted precise DORIS orbit 0100 : Estimated precise DORIS orbit during manoeuvre 0101 : Estimated precise DORIS orbit after interpolation (data gap) 0110 : Estimated precise DORIS orbit extrapolated on a time interval <1 day 0111 : Estimated precise DORIS orbit extrapolated on a time interval >1 day but <2 days 1000 : Estimated precise DORIS orbit extrapolated on a time interval >2 days or after manoeuvre
27	spare	0
26-25	Meteo data state	0: 2 maps nominal 1: 2 maps degraded 2: 1 map 3: no map
24	Processing error (arithmetic faults)	0: ok (no error) 1: error
23	spare	0
22	Ku Sea Ice retracking status	0: ok (no error) 1: error
21	S Ice 2 retracking status	0: ok (no error) 1: error
20	Ku Ice 2 retracking status	0: ok (no error) 1: error
19	S Ice 1 retracking status	0: ok (no error) 1: error
18	Ku Ice 1 retracking status	0: ok (no error) 1: error
17	S Ocean retracking status	0: ok (no error) 1: error



Bit Nos	Description	Values
16	Ku Ocean retracking status	0: ok (no error) 1: error
15-13	spare	0
12	Brightness Temperature Range check (channel 2)	0: in range 1: our of range
12	Brightness Temperature Range check (channel 1)	0: in range 1: our of range
10-8	validity	-
7	S-band anomaly flag (from cycle 51 onwards)	0: no errors 1: error
6	Wave form samples fault identifier	0: no errors 1: error
5	Rx delat Fault Identifier	0: no error 1: Rx distance out of range
4	AGC Fault Identifier	0: no error 1: AGC out of range
3	Fault Identifier	0: no errors detected 1: errors detected by on- board
2	USO validity flag	0: no errors detected 1: anomaly in USO value detected
1	OBDH validity flag	0: no errors detected 1: anomaly in OBDH value detected
0	Packet Length Error flag	0: no error detected 1: error detected and attempt to recover made

Table 4-9 Definition of variable instr_flags

Bit Nos	Description	Values
31-7	spare	0
6	Flag for availability of S flight calibration corrections	0: calibration parameters available 1: Calibration parameters not available -- default values used
5	Flag for availability of Ku flight calibration corrections	0: calibration parameters available 1: Calibration parameters not available -- default values used
4-2	PTR calibration band identifier field	0: 320 MHz (Ku) 1: 80 MHz (Ku) 2: 20 MHz (Ku) 4: 160 MHz (S) 7: PTR samples not available
1-0	Error flag for decoded redundancy flags	0: no mismatch detected 1: mismatch in Red_vec_HPA 2: mismatch in Red_vec_RFSS 3: mismatch in Red_vec_HPA and Red_vec_RFSS

Table 4-10 Definition of variable mwr_instr_flag

Bit Nos	Description	Values
15	Temp Flag (Tmp_flg) Indicates uniformity of CEU temperature	0: temperature consistency 1: temperature inconsistency
14	OBDH Flag (OBDH_flg) flag to indicate data is missing	0: no error 1: error
13	Red Flag: ICU channel redundancy indicator	0: normal channel 1: redundant channel
12	Power Bus Protection Flag (PBP_flg) Power Bus protection indicator	0: no protection 1: protection
11	Over Prot. flag Overvoltage/Overload protection indicator	0: no protection 1: protection
10-0	spare	0

Table 4-11 Definition of variable interpolate_flag

Bit numbers	Description	Values
15-4	spare	0
3	Meteorological data interpolation flag	0: ok (valid interpolation) 1: interpolation invalid
2	Ocean tide solution 2 interpolation flag	0: ok (valid interpolation) 1: interpolation invalid
1	Ocean tide solution 2 interpolation flag	0: ok (valid interpolation) 1: interpolation invalid
0	Mean Sea Surface interpolation flag	0: ok (valid interpolation) 1: interpolation invalid

For any specific variable, if there are associated flags, these will be identified using the “ancillary_variables” attribute. When using any variable from the CGDR file, the user should first check to see if any ancillary flag or map variables are defined, and then check these ancillary variables to determine the validity of the original variable.

Where possible, the SGDR flags applicable to 18 Hz variables have been unpacked to generate 18 Hz flags, and for each 18 Hz data point, the associated flag value will be set to zero (OK) or 1 (not ok). The variable-specific flags available in the COASTALT CGDR products are defined in Table 4-12.

**Table 4-12: Variable-specific flags available in the CGDR products**

Flag	Flag meaning	Related Variables
map_18hz_ku_trk	0: 18 hz value valid / used in 1 hz average 1: 18 hz value not valid/ used in 1 hz average	hz18_ku_trk_cog
map_18hz_ku_ocean_flags	0: 18 hz value valid/ used in 1 hz average 1: 18 hz value not valid/ used in 1 hz average	hz18_ku_band_ocean num_18hz_ku_ocean
map_18hz_s_ocean_flags	0: 18 hz value valid/ used in 1 hz average 1: 18 hz value not valid/ used in 1 hz average	hz18_s_band_ocean num_18hz_s_ocean
map_18hz_k_cal_ku_flags	0: 18 hz value valid/ used in 1 hz average 1: 18 hz value not valid/ used in 1 hz average	hz18_k_cal_ku
slp_mod_flags	0: slope model valid for 18 hz value 1: slope model not valid for 18 hz value	elev_echo_pt hz18_diff_mean_ech_pt
ku_ocean_retrk_qua_flags	Ku-band ocean retracking quality flags 0: valid measurement 1: invalid i.e. non tracking record, sum of all Ku and S waveform filters set to 0, Ku AGC or Ku onboard Rx delay out of bounds, leading edge out of bounds or average power smaller than a multiple of the noise power	hz18_ku_band_ocean
s_ocean_retrk_qua_flags	S-band ocean retracking quality flags 0: valid measurement 1: invalid i.e. non tracking record, sum of all Ku and S waveform filters set to 0, Ku AGC or Ku onboard Rx delay out of bounds, leading edge out of bounds or average power smaller than a multiple of the noise power	hz18_s_band_ocean
mwr_qua_interp_flag	MWR Quality interpolation flag (for 1 Hz data) 0: interpolation OK; no gap between the two MWR measurements around the RA-2 time 1: interpolation OK; but gap between the two selected MWR measurements 2: extrapolation was used 3: neither interpolation nor extrapolation used. The default value is output when no MWR data are available	mwr_wet_trop
mwr_wet_trop_interp_flag	Interpolation method used for 18Hz MWR wet trop value. 0: interpolated between 2 valid 1Hz MWR wet tropospheric correction values 1: interpolated between 2 valid 1Hz MWR wet tropospheric correction values, using model correction 2: extrapolated from 1 valid 1Hz MWR wet tropospheric correction values using model correction 3: no interpolation (invalid value)	hz18_mwr_wet_trop

In addition to the flag variables, a number of variables are provided which can be used in determining either the probably quality, or cause of poor quality, data. These variables are given in Table 4-13.

Table 4-13 Other quality Control Variables

Variable	Flag meaning
ku_peak	Peakiness of Ku-band waveform
s_peak	Peakiness of S-band waveform
gof_brown_ku	Goodness of fit of the Brown model to Ku-band waveform
gof_brown_s	Goodness of fit of the Brown model to S-band waveform
gof_spec_ku	Goodness of fit of the Specular model to Ku-band waveform
gof_spec_s	Goodness of fit of the Specular model to S-band waveform
gof_mixed_ku	Goodness of fit of the Mixed model to Ku-band waveform
gof_mixed_s	Goodness of fit of the Mixed model to S-band waveform
ocean_depland_elev	Ocean depth / land elevation
distance_from_coast	Distance to closest coast (see §3.5.3)

For those limited, regionally enhanced CGDRs which have had the GPD wet tropospheric correction data added, three quality control variables (Table 4-14) are provided to determine the quality of this correction.

Table 4-14 Additional quality control variables for GPD correction (in limited regional enhanced CGDRs)

Variable	Dimension	Meaning
<i>hz18_GPD_interp_flag</i>	time, samples	0: from valid open-ocean MWR correction 1: from GPD algorithm 3: points interpolated over land 9: 18 Hz interpolation not available
<i>hz18_GPD_formal_error</i>	time, samples	GPD correction formal error
<i>hz18_GPD_signal_variance</i>	time, samples	GPD correction variance

4.3.3.2 Detection of S-Band Anomaly

During the Commissioning Phase, it was discovered that the RA-2 data are affected by the so-called S-Band anomaly. The anomaly results in the accumulation of the S-Band echo waveforms, happens randomly after an acquisition sequence and is only stopped by switching the RA-2 into Stand-By mode. When this anomaly occurs, the S-Band waveforms are not meaningful and so all the S-Band parameters and the Dual Frequency ionosphere corrections are not reliable. Notably, the S-Band Sigma0 is unrealistically high during these events.

A method has been developed to flag the impacted data over all surfaces [RD 29]. This flag is available in the SGDR product from cycle 51 (see Table 4-8).



For cycles prior to cycle 51, an efficient method of detecting ocean data where the S-Band Anomaly occurs, is to applying a threshold of 5 dB on the (Ku-S) Sigma0 differences.

For cycle 10, 33% of the data are impacted (before any solution had been found), whilst for cycles 11-30, between 0 and 8% of the data are affected by the S-Band anomaly. From cycle 31 onwards, ESA performed some operation modifications to decrease the duration of these events: instrument switch-offs (Heater 2 mode) were performed twice a day over the Himalayan and Rocky mountain region. This prevents the S-Band anomaly from lasting more than half a day. Thanks to this procedure the proportion of impacted data decreased from 4.2% (cycles 11 to 30) to 2.2% (cycles 31 to 38) [AD 8].

On the 27th of June 2007 (cycle 60) an on-board patch solving the problem was successfully uploaded. Between then and the S-Band loss in January 2008, no occurrences of the anomaly have been detected.

An algorithm for the S-Band waveform reconstruction has been developed, but has not yet been implemented in the SGDR data.

4.3.4 Mean Sea Surface and Adjustment of the Cross Track Gradient

To study sea level changes between two dates, it is necessary to take the difference between sea surface heights from different cycles at the exact same latitude-longitude, to remove errors in the time-invariant geoid, which is not well known at short-wavelengths. However, the satellite ground track is allowed to drift by ± 1 km from its nominal position and so each repeat cycle of the satellite samples a different geoid profile. Differencing these profiles will introduce an error due to the poorly known cross-track geoid gradient. This error was estimated by [RD 3] as about 2 cm km^{-1} over most of the ocean. However, this effect is much larger where the expected geoid slopes are greater, *eg* over continental shelf slopes or coastal region. In addition, measurements are provided approximately every 1.1 s along the pass (about 7 km) for the "1 Hz" data, or every 0.055 s for the 18 Hz data (about 0.35 km). The position of these measurements along-track will be at different latitude-longitude locations on different cycles. Hence, even if the passes repeated exactly, it would be necessary to interpolate along the pass.

The Mean Sea Surface height is known to much greater accuracy, courtesy of previous altimetry missions, than the geoid height. Hence the use of SLA is of benefit in looking at repeated data. Interpolation of SLA to a repeated track location generates smaller errors than interpolating the Sea Surface Height.

Over the open ocean it is common to interpolate data to a common set of along-track points, or "reference" track. Whilst this approach may be beneficial in the open ocean, the smaller spatial scales of the coastal zone might make this less beneficial, and alternative approaches, including the use of a locally generated mean sea surface as carried out in the X-TRACK processor [RD 36] might be more appropriate.

4.3.5 Smoothing Ionosphere Correction

The ionospheric (range) correction is expected to be negative, but positive values of the dual frequency ionospheric correction values may occur due to instrument noise effects. To reduce the noise, it is recommended that these parameters are averaged over 100 km or more [RD 23].

In order to provide a reversible correction, no averaging is performed on the dual frequency ionospheric corrections provided on the CGDR. Users may smooth the ionospheric correction along-track before applying, although care should be taken close to land. Typical and maximum smoothing scales are 100-150 km for local times between 06 and 24 hours and 150-200 km for local times between 00 and 06 hours. The shorter (longer) smoothing time is also more appropriate during times of high (low) solar activity

4.3.6 Generation of 1 Hz Averages

Each 1 Hz value from the altimeter measurements (range, wave height and sigma-0) is derived from the linear regression of the valid 18 Hz parameters determined from the retracking algorithms.

The number of valid 18 Hz measurements (`num_18hz_[ku/s]_ocean`, `num_18hz_[ku/s]_ocean_swh` and `num_18hz_[ku/s]_ocean_bscat` for ocean retracked range, wave height and backscatter) that are used to derive each of the 1 Hz measurements is provided on the CGDRs, together with the map identifying which values these are (`map_18hz_[ku/s]_ocean_flags` and `map_18hz_k_cal_ku_flags` for range and backscatter), and the root-mean-square of the differences between the valid 18 Hz measurements and the derived 1 Hz measurement (`sd_18hz_[ku,s]_ocean`, `sd_18hz_[ku,s]_swh` and `sd_18hz_[ku/s]_ocean_bscat`).

For coastal regions, users may wish to generate averaged values from the 18 Hz measurements.



5 Altimetric data

This section presents a short discussion of the main quantities on the CGDR, with emphasis on the parts of the system that may provide particular challenges in the coastal zone.

An excellent overview of the theoretical and practical effects of radar altimetry is the “Satellite Altimetry” Chapter in [RD 10].

5.1 Altimeter Range

An altimeter operates by sending out a short pulse of radiation and measuring the time required for the pulse to return from the sea surface. This measurement, the altimeter range, gives the distance between the instrument and the sea surface, provided that the velocity of the propagation of the pulse and the precise arrival time are known. The dual frequency altimeter on Envisat performs range measurements at the Ku and S-band frequencies enabling measurements of the range and the path total electron content. While both range measurements are provided on the CGDR the Ku-band range measurement has higher accuracy than the S-band measurement.

The ranges reported on the CGDR have already been corrected for a variety of calibration and instrument effects, including calibration errors, pointing angle errors, centre of gravity motion, and terms related to the altimeter acceleration such as Doppler shift and oscillator drift. **Note:** there is a known error in the correction due to jumps in the Ultra Stable Oscillator (USO) that has *not* been applied to this version of the data, but the relevant correction (`uso_clock_correction`) is provided and must be added to the range as explained in §4.3.1. The sum total of these corrections also appears on the CGDR for each of the Ku and C band ranges.

In the coastal ocean, there is an increased probability that there will be land in the altimeter footprint, and this produces a very different return signature to ocean surfaces. The standard Brown model retracker will not recognise these returned signals and will be unable to provide valid range, wave height and sigma-0 values. In these circumstances, the COASTALT specular, or mixed retracker, may provide valid range information.

5.2 Geoid

The geoid is an equipotential surface of the Earth's gravity field that is approximated by the mean sea surface. The time-mean ocean currents are the primary cause of deviation of the mean sea surface from the geoid. The reference ellipsoid is a bi-axial ellipsoid of revolution.

The geoid undulation, over the entire Earth, has a root mean square value of 30.6 m with extreme values of approximately 83 m and -106 m. Although the geoid undulations are primarily long wavelength phenomena, short wavelength changes in the geoid undulation are seen over seamounts, trenches, ridges, etc., in the oceans, and approaching coasts, particularly across the continental shelf slopes. The calculation of a high resolution geoid requires high resolution surface gravity data in the region of interest as well as a potential coefficient model that can be used to define the long and medium wavelengths of the Earth's gravitational field. Surface gravity data are generally only available in certain regions of the Earth and spherical harmonic expansions of the Earth's gravitational potential are usually used to define the geoid globally. Currently, such expansions are available to degree and order 360 (approximately

100 km) and in some cases higher, although the majority of the information at higher degree and order (shorter wavelengths) comes from the mean sea surface determinations used in the geoid modelling.

5.3 Mean Sea Surface

A Mean Sea Surface (MSS) represents the average sea surface height over an appropriate time period, usually designed to remove annual, semi-annual, seasonal, and mesoscale sea surface height signals, as well as minimising noise. A MSS field is usually provided as a grid with spacing consistent with the altimeter and other data used in the generation of the grid values. A MSS grid can be useful for data editing purposes, for the calculation of along track and cross track geoid gradients, for the calculation of gridded gravity anomalies, for geophysical studies, for a reference surface to which sea surface height data from different altimeter missions can be reduced, etc. The CGDR provides a global MSS model that is generated from multiple satellite altimetry missions. This model relies on previous altimetry data, which has poor sampling in the coastal zone. Hence the errors in the mean sea model in the coastal regions are larger than in the open ocean.

Longer time spans of data that become available in the future, along with improved data handling techniques will improve the current MSS models. Care must be given to the retention of high frequency signal and the reduction of high frequency noise.

5.4 Mean Dynamic Topography

A Mean Dynamic Topography (MDT) represents the Mean Sea Surface referenced to a geoid and corrected for geophysical effects. A MDT is generally generated as a grid with spacing consistent with the altimeter and other data used in the generation of the grid values. The MDT provides an absolute reference surface for the ocean circulation. The CGDR provides a global MDT model that is a combined product based on the GRACE mission, altimetry and in situ data (hydrologic and drifters data).

As the MSS from altimetry forms a major contributor to the MDT, then the same consideration must be given to the lack of data in coastal regions increasing the model errors.

5.5 Geophysical Corrections

Atmospheric components act to retard the radar pulse, which increases the calculated range and the sea surface height estimate is too low. The retardation effect is controlled by the composition of the atmosphere, which is the electron content of the ionosphere, the dry gas composition of the troposphere and its water content, both as vapour and in clouds (the most variable parameter). The ionospheric effect produces a range increase of only around 20 cm whilst the dry gases result in an increase of order 2.3 m. The highly variable water vapour content can cause increases of between 5 and 40 cm.

Discussions of these effects are given in [RD 10].



5.5.1 Troposphere (dry and wet)

The propagation delay caused by the troposphere is a combination of the effect of the dry gas and water components. The dry tropospheric correction uses model atmospheres, derived from empirical data on the vertical structure of the atmosphere. The CGDR dry tropospheric correction uses the surface pressure of the ECMWF model, interpolated onto the satellite tracks. The dry tropospheric correction is then calculated using;

$$dry_tropo_corr = -2.277p(1 + (0.0026\cos 2\phi))$$

where;

p is surface atmospheric pressure (mbar)

ϕ is latitude

Despite being the largest transmission path correction at more than 2 m, it is estimated as being accurate to 2-3 cm and so is not a major contributor to residual errors. Typical errors in the model pressure field vary from 1 mbar in the northern Atlantic Ocean to a few mbars in the southern Pacific Ocean. A 1-mbar error in pressure translates into a 2.3 mm error in the dry tropospheric correction. There may be changes in atmospheric pressure in coastal regions, but these are not anticipated to have a major impact on the errors introduced by this correction.

The water content of the troposphere is a far more variable parameter than the atmospheric pressure. In addition, it is possible that coastal atmospheric effects may generate even higher spatial variability in this parameter in coastal regions, making it of particular importance in coastal altimetry. The water content can be found in one of two ways. A passive radiometer, such as the MWR flown on Envisat, allows direct measurement of water content by comparison of the different channels of the MWR along its ground track. One major draw-back of this method in the coastal zone is the size of the MWR footprint. At more than 30 km from the coast, the MWR measurements, and hence the wet tropospheric delay correction, may be contaminated by land in the footprint, making the correction unusable.

An alternative method is to use a numerical atmospheric model (ECMWF for CGDR) output of surface air temperature and water vapour pressure. This correction is believed to have an accuracy of within 5 cm, limited by poor meteorological station coverage over large areas of the world's oceans and poor estimates of water vapour content in regions such as the inter-tropical convergence zone in the model. As for the dry tropospheric correction, the model grid is interpolated onto the satellite track.

The major advantage of the model value is that it is available even where there is land contamination in the MWR footprint, or anomalous sensor behaviour makes the MWR measurements unusable.

The Dynamically Linked Model (DLM, see §3.5.2) aims to extend the MWR correction to cover short gaps in coverage, or extend the MWR correction towards the coast. Small gaps in the MWR available are filled by simple linear interpolation. Approaching land, the model extrapolates the MWR correction, using the model correction profile, offset to remove any bias between this correction and the MWR value at the closest approach to land. For larger gaps, eg over small islands, where the MWR value is available at either end of the gap, then a slope, as well as a bias, is applied to the model correction, to ensure the DLM correction has no step changes along-track.

The novel GPD Wet Tropospheric Correction [AD 13, AD 14, AD 15 RD 15] is also available in some, regional enhanced, CGDR products. This correction uses GNSS signals to derive the path

delay. When available, the correction is also supplied with associated variance of the correction and the formal error (see Table 7-4). See [RD 15] for more details.

5.5.2 Ionosphere

At the frequencies used by the RA-2, propagation delay caused by the ionosphere is proportional to the integrated free electron density, also known as the total electron content (TEC). The delay is inversely proportional to frequency squared and introduces a range increase of approximately 0.2 to 20 cm at 13.6 GHz. For mid-latitudes diurnal and solar source (sun-spot) effects have been recorded as causing variation from approximately 5 to 100×10^{16} electrons m^{-2} [RD 4] with lower values occurring overnight and in the Summer. The frequency dependence of the delay can be utilized by means of a dual frequency altimeter such as RA-2, for which comparison of the two measured heights determines the local ionospheric effect. As this correction is determined by the Ku and S-band range measurements, corrected for sea-state bias effects, the dual-frequency correction is dependant on the retracking method and care must be taken to use an appropriate correction for the range selected. Also, see §4.3.5 on smoothing the ionospheric correction.

The electron content can also be determined by alternative methods. The CGDR provides corrections based on the ionospheric measurements provided by the DORIS instruments, and also from a global ionospheric model, the Global Ionosphere Maps (GIM). These corrections may be used over non ocean surfaces (ice, land, etc.).

5.5.3 Ocean Waves (sea state bias)

The interaction of the radar pulse with the sea surface is influenced by the local sea-state through several mechanisms. Ocean wave troughs are inherently more likely to contribute to the return radar signal, as they scatter back towards the satellite, whereas wave crests scatter away from the satellite. Hence the return pulse is biased toward the troughs of the waves. This bias, known as the EM bias, means the range tends to be overestimated relative to the mean surface position [RD 37]. The EM-bias is dependant on the wave height and frequency of the radar pulse and should be the same for all instruments operating at the same frequency. Ocean waveforms also tend to be 'peaky' – ie have narrow peaks, and broad, wide troughs, introducing a skewness bias from the assumption that the probability density function of heights is symmetric. Finally, there is a tracker bias, which is a purely instrumental effect, instrument dependant. The sum of EM bias, skewness bias and tracker bias is called 'sea state bias'.

The current estimates of sea state bias are obtained using empirical models derived from analyses of the altimeter data. The sea state bias is computed from a bilinear interpolation of a table of sea state biases versus significant wave height and wind speed, based on empirical fits. For a typical significant wave height (SWH) of 2 m, the sea state bias is about 10 cm, and the error (bias) in the sea state bias correction is approximately 1-2 cm. The noise of the sea state bias estimates depends mainly on the noise on the significant wave height estimates. The relationship between SWH, wind speed and sea state bias will not necessarily be the same for coastal regions as for open ocean. In addition, the relationship will be different for different trackers. However, the analysis requires large volumes of data, which have not previously been available in the coastal areas, and has not yet been carried out using the alternative retrackers used in COASTALT, and so the open ocean relationship is the best currently available.



5.6 Rain Flag

Liquid water along the pulse's path reduces the energy returned to the altimeter, mainly at Ku-band. In heavy rain, there are competing effects from attenuation and surface changes. The effect is more pronounced on the Ku-band return than on the S-band. The small-scale nature of rain cells tends to produce rapid changes in the strength of the echo as the altimeter crosses rain cells. Both effects degrade the performance of the altimeter. Data contaminated by rain should be ignored.

The rain flag on the CGDR is set if the expected Ku/S-band rain-free relationship, minus the uncorrected Ku ocean backscattering coefficient, and if the MWR liquid water content, interpolated to RA-2 time, are both larger than certain thresholds. This flag may be unreliable in coastal regions, where the MWR measurements are not available. It may be possible to use the Ku-band rain attenuation correction (`ku_rai_corr`) [RD 42] to determine if there is rain in the footprint. This value uses the difference between the Ku-band σ_0 measurement and a predicted Ku-band value, determined using the S-band σ_0 and the normal relationship between S-band and Ku-band σ_0 values.

5.7 Tides

Tides are a significant contributor to the observed sea surface height [RD 26]. While they are of interest in themselves, they have more variation than all other time-varying ocean signals and they must be removed to study ocean circulation effects. The Envisat orbit is not ideal for studying tides, as the key diurnal and semidiurnal tides are aliased to low frequencies (or infinity) by the sun-synchronous orbit.

There are several contributions to the tidal effect: the ocean tide, the load tide, the solid earth tide and the pole tide. The ocean tide, load tide and solid earth tide are all related to luni-solar forcing of the earth, either directly as is the case of the ocean and solid earth tide, or indirectly as is the case with the load tide since it is forced by the ocean tide. The pole tide is due to variations in the earth's rotation axis and is unrelated to luni-solar forcing.

CGDRs do not explicitly provide values for the pure ocean tide, but instead provide values for a quantity referred to as the geocentric ocean tide, which is the sum total of the ocean tide and the load tide. Values of the load tide that were used to compute the geocentric ocean tide are also explicitly provided, so the pure ocean tide can be determined by subtracting the load tide value from the geocentric ocean tide value. Note that the permanent tide is not included in either the geocentric ocean tide or solid earth tide corrections that are provided on the CGDRs. Hence the sea surface heights calculated will be in the mean-tide reference frame, which should be considered when combining with external geodetic heights, which might use a zero-tide or tide-free reference frame.

5.7.1 Geocentric Ocean Tide

As mentioned above, the geocentric ocean tide refers to the sum total of the ocean tide and the load tide. The CGDR provides two choices for the geocentric ocean tide, `tot_geocen_ocn_tide_ht_sol1` and `tot_geocen_ocn_tide_ht_sol2`, each of which is computed as the sum total of the diurnal and semidiurnal ocean and load tides as predicted by a particular model, and an equilibrium representation of the long-period ocean tides at all periods except for the zero frequency (constant) term. The two load tide values provided on the GDR,

tidal_load_ht_sol1 and tidal_load_ht_sol2, provide the respective load tide values that for the total geocentric tide solutions.

5.7.2 Long period Ocean Tide

The long-period ocean tides are a subject of continuing investigation. To first order, they can be approximated by an equilibrium representation. However, the true long-period ocean tide response is thought to have departures from an equilibrium response that increase with decreasing period. The two principal long-period ocean tide components, Mf and Mm, with fortnightly and monthly periods respectively, are known to have departures from an equilibrium response with magnitudes less than 1-2 cm.

The CGDR explicitly provides a value for an equilibrium representation of the long-period ocean tide that includes all long-period tidal components excluding the permanent tide (zero frequency) component (see parameter long_period_ocn_tide_ht). Note that both geocentric ocean tide values on the CGDR already include the equilibrium long-period ocean tide and should therefore not be used simultaneously.

5.7.3 Solid Earth Tide

The solid Earth also responds to external gravitational forces. The response of the Earth is fast enough that it can be considered to be in equilibrium with the tide generating forces. Then, the surface is parallel with the equipotential surface, and the tide height is proportional to the potential. The two proportionality constants are the so-called Love numbers. It should be noted that the Love numbers are largely frequency independent, an exception occurs near a frequency corresponding to the K1 tide constituents due to a resonance in the liquid core [RD 43 and RD 39].

The CGDR computes the solid earth tide, or body tide, as a purely radial elastic response of the solid Earth to the tidal potential (see parameter solid_earth_tide_ht). The adopted tidal potential is the Cartwright [RD 8] tidal potential extrapolated to the 2000 era, and includes degree 2 and 3 coefficients of the tidal potential. The permanent tide (zero frequency) term is excluded from the tidal potential that is used to compute the solid earth tide parameter.

5.7.4 Pole Tide

The pole tide is a tide-like motion of the ocean surface that is a response of both the solid Earth and the oceans to the centrifugal potential that is generated by small perturbations to the Earth's rotation axis. These perturbations primarily occur at periods of 433 days (called the Chandler wobble) and annual. These periods are long enough for the pole tide displacement to be considered to be in equilibrium with the forcing centrifugal potential. The CGDR provides a single field for the radial geocentric pole tide displacement of the ocean surface (see geocen_pole_tide_ht parameter), and includes the radial pole tide displacement of the solid Earth and the oceans.

The pole tide is easily computed as described in [RD 43]. Modelling the pole tide requires knowledge of proportionality constants, the so-called Love numbers, and a time series of perturbations to the Earth's rotation axis, a quantity that is now measured routinely with space techniques. Note that the pole tide on the IGDR and GDR may differ, since the pole tide on the GDR is computed with a more accurate time series of the Earth's rotation axis.



5.8 Inverse Barometer Effect

5.8.1 Inverted Barometer Correction

As atmospheric pressure increases and decreases, the sea surface tends to respond hydrostatically, falling or rising respectively. Generally, a 1-mbar increase in atmospheric pressure depresses the sea surface by about 1 cm. This effect is referred to as the inverse barometer (IB) effect.

The instantaneous IB effect on sea surface height in millimeters is computed from the surface atmospheric pressure (`mod_surf_atm_pres`), P_{atm} in mbar:

$$\text{inv_barom_corr} = -9.948 * (P_{atm} - P)$$

where P is the time varying mean of the global surface atmospheric pressure over the oceans.

The scale factor 9.948 is based on the empirical value [RD 44] of the IB response at mid latitudes. Some researchers use other values. Note that the surface atmospheric pressure is also proportional to the dry tropospheric correction, and so the parameter `inv_barom_corr` changes by approximately 4 to 5 mm as `mod_dry_tropo_corr` changes by 1 mm (assuming a constant mean global surface pressure). The uncertainty of the ECMWF atmospheric pressure products is somewhat dependent on location. Typical errors vary from 1 mbar in the northern Atlantic Ocean to a few mbars in the southern Pacific Ocean. A 1 mbar error in pressure translates into a 10 mm error in the computation of the IB effect.

5.8.2 Barotropic/Baroclinic Response to Atmospheric Forcing

The High Frequency Wind and Pressure Response correction, `dib_hf`, complements the Inverted Barometer (IB) correction. Like both tides and IB, the ocean response to wind and pressure (after removing the IB part) has energy at periods shorter than the 70 day implied by the 35day repeat cycle of Envisat. This correction can be thought of as a departure from the IB response to pressure, although strictly it is the difference between the response to wind and pressure minus the IB. This response is calculated using a barotropic model. The parameter `dib_hf` is a correction to the inverse barometer correction `inv_barom_corr`.

5.9 Sigma 0

The backscatter coefficients, `sigma-0` Ku and S-band values (see parameters `ku_ocean_bscat_coeff` and `s_ocean_bscat_coeff`), reported on the CGDR are corrected for atmospheric attenuation using `ku_atm_atten_corr` and `s_atm_atten_corr`.

5.10 Wind Speed

The model functions developed to date for altimeter wind speed have all been purely empirical. The model function establishes a relation between the wind speed, and the sea surface backscatter coefficient and significant wave height. A wind speed is calculated through a mathematical relationship with the Ku-band backscatter coefficient and the significant wave height (see `ra2_wind_sp`) using the algorithm proposed by Abdalla [RD 1]. The wind speed model function is evaluated for 10 m above the sea surface.

A 10 m (above surface) wind vector (in east-west and north-south directions) is also provided on the CGDR (see parameters `mod_wind_sp_u` and `mod_wind_sp_v`). This wind speed vector is determined from an interpolation of the ECMWF model. The best accuracy for the wind vector varies from about 2 ms^{-1} in magnitude and 20 degrees in direction in the northern Atlantic Ocean, to more than 5 ms^{-1} and 40 degrees in the southern Pacific Ocean.

5.11 Bathymetry Information

The CGDR provides a parameter bathymetry that gives the ocean depth or land elevation of the data point. Ocean depths have negative values, and land elevations have positive values. This parameter is given to allow users to make their own "cut" for ocean depth.



6 Coastal Case Studies

6.1 Western Iberia: Applying Quality Control to Sea Surface Heights

In this case study, we present a method for applying quality control (QC) to coastal altimetry data. For QC retracked heights the following quantity was considered:

$$\text{retracked height} = \text{altitude} - (\text{range} + \text{USO})$$

where:

altitude is the satellite ellipsoidal height; range is the ku-band range from the COASTALT mixed retracker; USO is the USO correction.

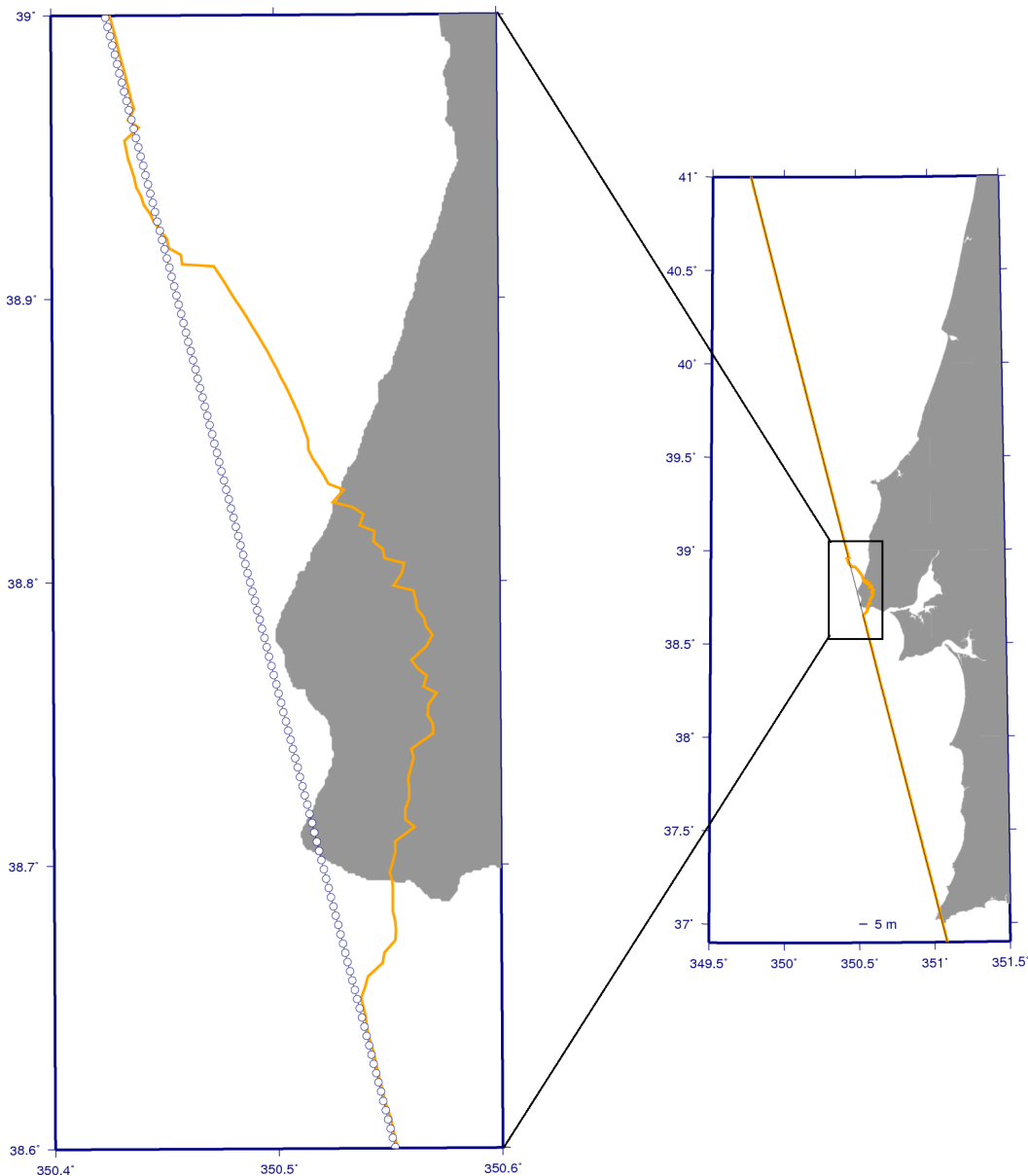

Figure 7: retracked heights (—) plotted as along-track anomalies for identification of anomalous along-track measurements (○) close to the coast.

The inspection of maps of retracked heights plotted as along-track anomalies allows an assessment of the validity of retracked heights close to the coast, as illustrated in Figure 7 for pass 001 along the west Iberia margin (cycle 10).

Time series of sea-level anomalies can be derived from stacked altimetry measurements as

$$SLA = [\text{altitude} - (\text{range} + \text{corrections})] - \text{mssh}$$

Where

mssh is the mean sea surface height

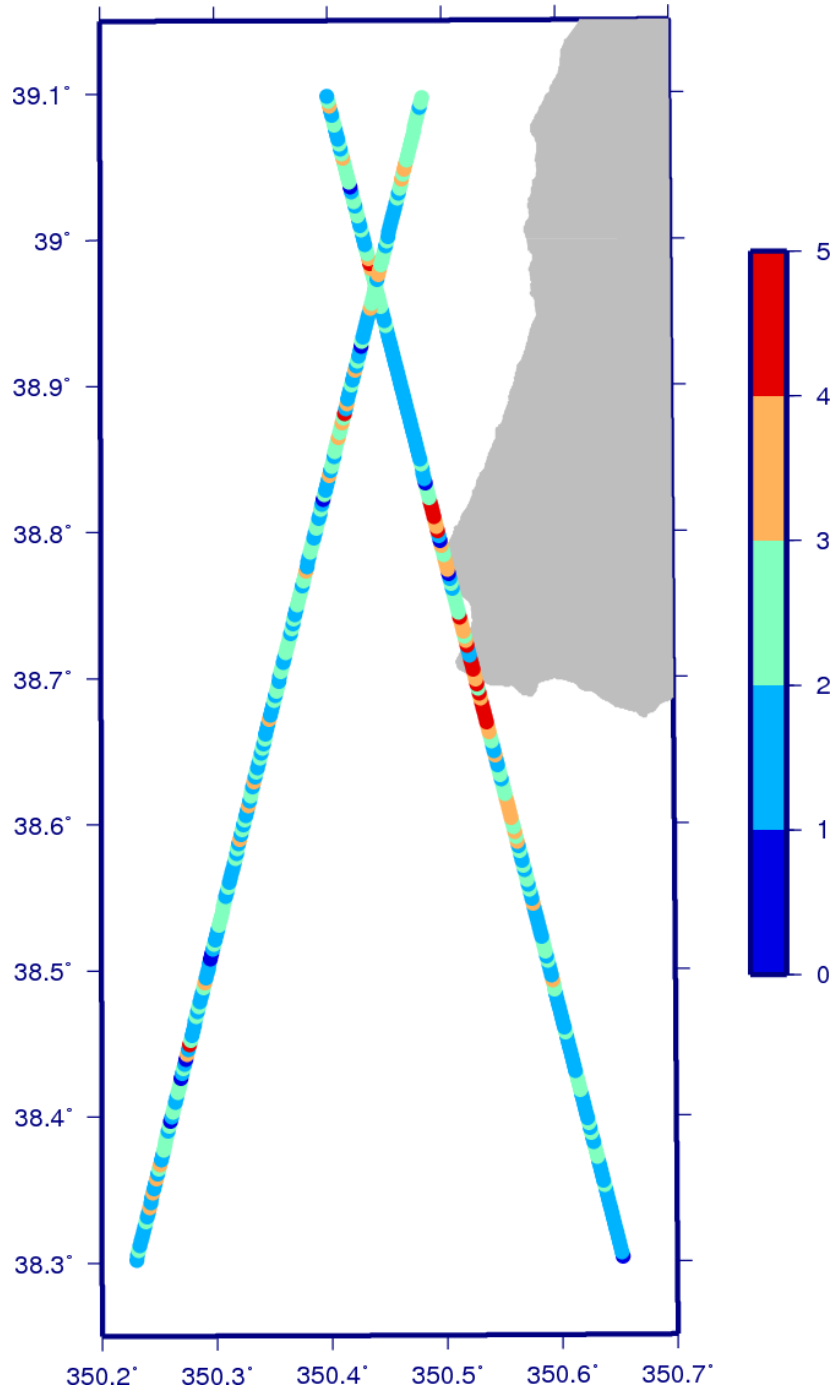

Figure 8: Map of the number of cycles identified as having outlying values



Each time series (at a given along-track location) is inspected for potential outlying values, set as anomalies exceeding 2.5 times the standard deviation of the series over the whole period. Figure 8 shows the number of values identified as outliers for a region around the Cascais tide gauge, west Iberia coast. At most along-track locations less than 3 cycles were identified as having outlying values, with that number increasing up to 5 very close to the coast. The corresponding cycle numbers are displayed in Figure 9, which shows that for the whole set of along-track points, cycles 39 and 66 were the cycles most often identified as outliers.

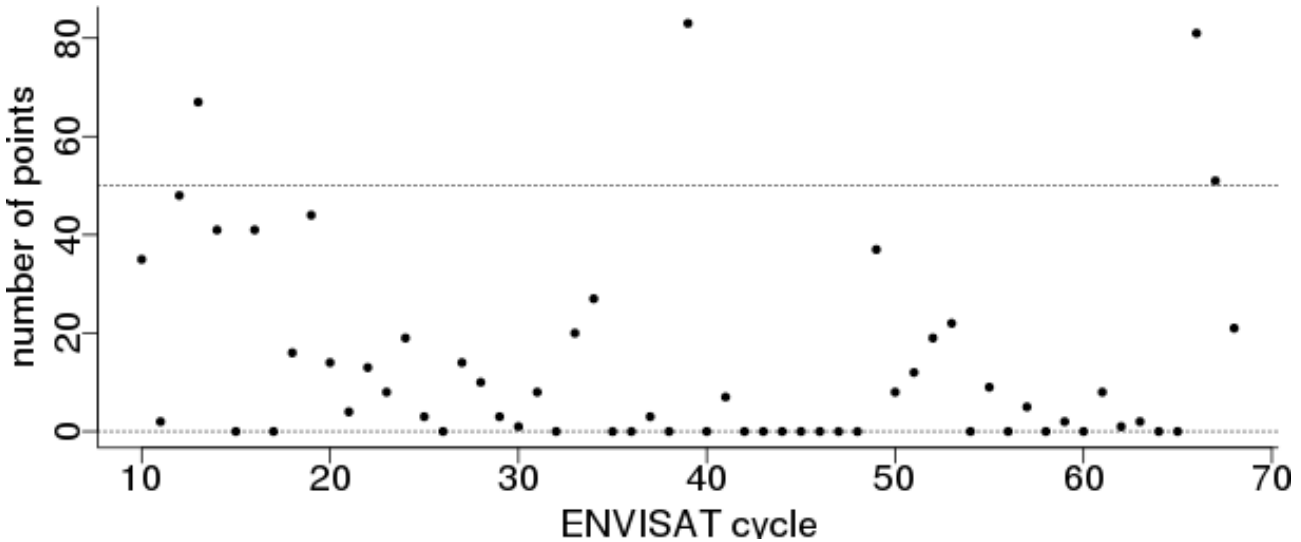

Figure 9: Number of the along-track points (in Figure 8) for which each ENVISAT cycle was identified as outlying (exceeding 2.5 the standard deviation of the SLA series)

6.2 Iberian Peninsula: Evaluation of Wet Tropospheric Corrections

In this case study, we present an example of evaluation of the new wet tropospheric corrections available on the CGDR for a specific region, by comparison of resulting anomalies with tide gauge data. The wet tropospheric correction (WTC) accounts for the highly variable water vapour content in the troposphere. Due to the large footprint of microwave radiometers, the radiometer-derived wet tropospheric delays are problematic near the coast. Three approaches are considered for the wet tropospheric correction:

WTC from the Dynamically Linked Model (DLM)

WTC from the ECMWF model

WTC from a GNSS-based method (GPD)

In order to assess the effect of the three types of WTC correction on COASTALT data, the resulting time series of sea-level anomalies (computed using the same formula as in §6.1) are compared with tide gauge (TG) observations, linearly interpolated to the satellite overpass time. Time series of differences are obtained by subtracting the tide gauge observations from the corresponding altimetry data. The standard deviation of the differences between COASTALT and Cascais tide gauge data are summarised in Figure 10, which shows very similar results for the three corrections, though the GNSS-based wet troposphere correction (GPD) yields slightly less variable and smaller differences to the in-situ tide gauge values.

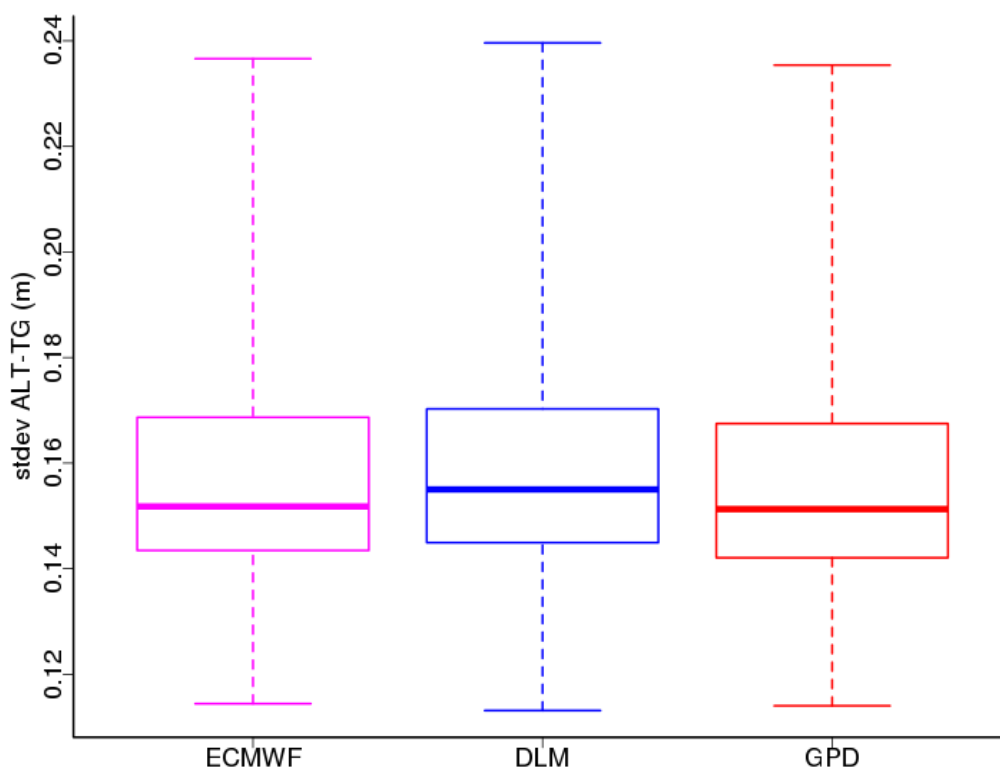

Figure 10: Standard deviation of differences between COASTALT and tide gauge values at the Cascais tide gauge for the three wet troposphere corrections

6.3 Gulf of Cadiz: Validating Significant Wave Height Data

In this work we analyzed the accuracy of ENVISAT RA-2 wave measurements in the Gulf of Cadiz, addressing the problem of satellite altimetry data improvement near the shoreline. The Gulf of Cadiz is a wide basin located in the southwestern of the Iberian Peninsula connecting the Atlantic Ocean and the Mediterranean Sea through the Strait of Gibraltar (Figure 11). The continental shelf from the east of Cape Santa Maria to the west of the Bay of Cadiz is quite broad (~ 50km). The coast is predominated by marshes, beaches and estuarine zones, and receives significant fluvial inputs associated with the discharge of major rivers such as the Guadiana and the Guadalquivir [RD 17]. This crucial environment has undergone substantial rapid agricultural, fisheries, and anthropogenic development, particularly in recent decades.



Figure 11: Location of the study area showing ENVISAT track 223 and the AWAC (A) and Gulf of Cadiz (G) coastal buoys. Ground tracks are depicted with yellow dots indicating the position of the 1 Hz measurements (Google Earth copyright).

An eight-year data set (2002-2009; cycles 11 through 84) along ENVISAT pass 223 was selected, that crosses the continental shelf of the Gulf of Cadiz in front of the Guadalquivir River mouth (Figure 11). The dataset includes the 1 Hz (approx. 7.5 km along track spacing) SWH (Significant Wave Height) from the SGDR Brown fit (`ku_sig_wv_ht`) and the 18 Hz (350 m along-track spacing) SWH from the COASTALT Brown retracker (`brown_swh_ku`). In a first step, the COASTALT 18 Hz SWH data were reduced to 1 Hz (by averaging twenty points) and inter-compared with the SGDR sourced data. To remove remaining spurious records, data were rejected if the land flag was set (`altim_landocean_flag=1`), the peakiness value was over 20 (`ku_peak>1.8`), any SWH value was reported as zero or default value and if the number of valid 18 Hz SWH measurements was less than 18 (`num_18hz_ku_ocean_swh<18` for the SGDR data). The time series were further processed with the removal of all the observations for which $SWH > 15$ m or $SWH < 0.15$ m. In a second step, we validated the SWH data against ground-truth data available in the study area.

These data have been compared to *in situ* data from two Wave Buoys (AWAC - A and Gulf of Cadiz - G). The results of regression analysis of the buoy in an exposed location (G) showed very high correlation for both datasets: SGDR (N=797) and COASTALT (N=787), and were statistically significant at the 95% level, with most regression line slope close to, but slightly more than 1.0. The closest 1 Hz track point to the buoy (20 km) offered the best fit in both data streams: 0.17 m rms, 0.006 m bias and R=0.97 (SGDR) and 0.15 m rms, 0.007 m bias and R=0.96 (COASTALT), presenting consistent altimeter products typical of more offshore locations.

The outcomes of the sheltered water moored AWAC located in the estuarine zone of the Guadalquivir River (10 km from the coast), a very dynamic area, are presented in Figure 12. The regression analysis gives high correlation for both datasets and good agreement is inferred for the track points located 10-15 km away from the shore-line. The rms (m), bias (m) and R values along-track for each altimeter point and for the two data streams are displayed with respect to distance to coast and the separation from the in-situ station. Due to near-shore ground-truth data availability the number of observation is lower than for the offshore station, with N=161. The SGDR data show a bias, overestimating SWH with respect to the buoy measurements over the entire segment of along-track analyzed, especially in the first two points. The bias slightly increases with distance from the buoy. Figure 12 also indicates that variability increases monotonically with satellite/buoy distance. The best fit corresponds to the minimum along-track point's distance to the buoy (~11 km in point 4). Figure 13 presents the scatter of SWH from ground-based observations against altimeter GDR retrieval for track point 4 (dots), showing that the total collocations are situated above the 1:1 line with a positive bias in the satellite data. Average scatter about the regression line amounts to 0.36 m rms, 0.28 m bias, and with a correlation coefficient R=0.78. It is known that in coastal systems the background energy may significantly vary within the region and affect the wave spectra differently [RD 19]. Firstly, the effects associated with the remaining dispersion are interpreted due to local variations in wave climate because of the proximity to land. Secondly, the low correlation of two track points 1 and 2 (1.5 and 9 km distance from coast, respectively) demonstrated that, in addition to the coastal processes, the effects of land contamination in the altimeter footprint might distort the retrieval of SWH.

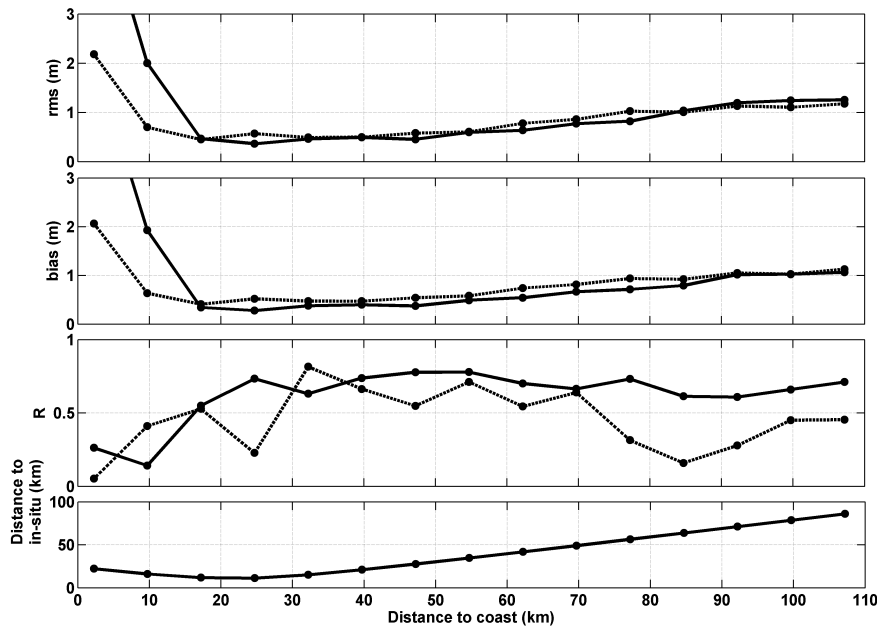

Figure 12: Statistics (rms, bias and R) resulting from the comparisons of significant wave height from the altimeter products against in-situ observations from the AWAC coastal buoy with respect to the distance to coast. Continues lines correspond to SGDR datasets and dashed lines to COASTALT CGDR. The distance to in-situ emplacement of each track point in the bottom of the plot.

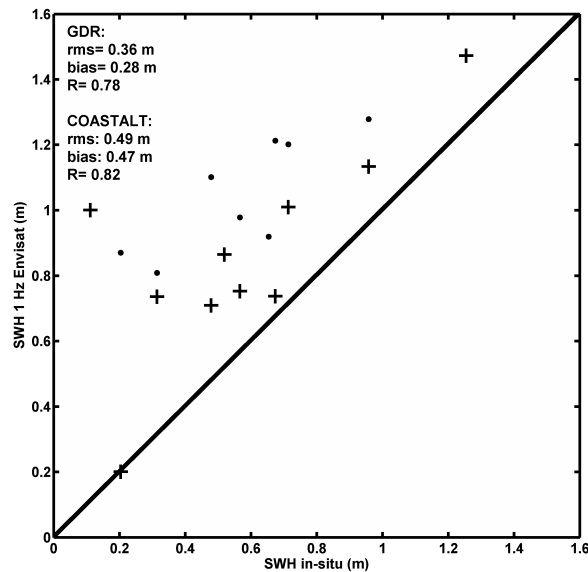

Figure 13: Comparison of significant wave height records from the AWAC coastal buoy versus altimeter 1 Hz of track point 4 from the SGDR data (dots) and of track point 5 from COASTALT measurements (crosses).

The COASTALT records show quite a good correspondence with the in-situ data, similar to the SGDR data, with a total of 120 collocations (Figure 12). Overall, there is a positive bias in the CGDR data (higher nearshore). This agrees well with previous work and with the SGDR comparisons, suggesting that altimeter systematically overestimates SWH with respect to ground-truth observations. The differences decrease as we approach the buoy location (as for the SGDR data) and, accordingly, the best fit appeared is at track point number 5, at 20 km from the buoy, with a correlation factor of 0.82, 0.49 m rms and 0.47 m bias. The scatter at

point 5 can be observed in Figure 13 (crosses), representing an overestimation of the satellite data (regression line slope greater than 1).

In general, the rms between the two respective data streams was found to be similar, with the exception of the two closest points to coast, where there were lower differences for the COASTALT data. In fact, the second 1 Hz point (COASTALT) has rms and bias values of the same order of magnitude as the offshore points.

Apart from the discrepancy for the two points nearest to shore, the comparative statistics of both analyses are very similar, with both the COASTALT and SGDR records persistently overestimating wave conditions with respect to the in-situ observations. In general, the results demonstrate extremely good agreement between the buoy and the altimeter SGDR and COASTALT measurements. The altimeter estimates of SWH are characterized by stable performance, indicating that the spatial and temporal variability of the wave field is well reproduced in this coastal region. The results from the two points closest to shore clearly demonstrate the influence of land contamination on SWH retrieval, from both SGDR (more intensely) and COASTALT retracker, providing a limit of approx. 15 km from shore for reliable use of the altimetry SWH data in this region. However, the retracker used in COASTALT seems to retrieve marginally less noisy SWH.

Full details of this work can be found in [RD 5].



7 Data description

The CGDR products are primarily sourced from the SGDR products. A limited number of auxiliary files have been used in generating the current version of the CGDR products. The auxiliary files used are detailed in the global attributes of the product and include the configuration data file, the characterization data file and the USO correction data file. Other parameters regarding waveform fitting have been derived from ESA documentation.

7.1 Data format

Envisat CGDR products contain both “1Hz” and “18 Hz” values in netCDF format. The 1 Hz values are held in 1 dimensional variables, whilst the 18 Hz data are held in 2 dimensional variables: the first dimension corresponds to the 1 Hz data dimension, and the second dimension is 20, the number of samples used in each 1Hz average value.

The COASTALT CGDR data product uses the netCDF (network Common Data Form) data format. NetCDF is a set of software libraries and machine-independent data formats that support the creation, access, and sharing of array-oriented scientific data. The format was chosen as it is extremely flexible, self-describing, platform independent and has been adopted as a de-facto standard for many operational oceanography systems. Although the latest version of netCDF (v 4) has advantages in terms of data compression, CGDR files are produced in netCDF v 3 format, to retain maximum compatibility with existing software and for simplicity of installation, as it does not require the additional HDF 5 and compression libraries. The v3 files are compatible with v4 libraries and software.

In addition, the data and metadata within the files follow the Climate and Forecast netCDF conventions CF-1.4 wherever applicable, in order to take advantage of generic software and tools developed to read and manipulate data files that conform to these standards.

7.1.1 The NetCDF Data Model

A netCDF file contains **dimensions**, **variables**, and **attributes**, which all have a name by which they are identified. Each of these components has corresponding characteristics, which define what it holds and how it can be used. These components can be used together to capture the meaning of data and relations among data fields in an array-oriented data set.

7.1.1.1 Dimensions

A dimension may be used to represent a real physical dimension, for example, time, latitude, longitude or height. Variables may share common dimensions, relating them to the same grid. A dimension might also be an index for other quantities (waveform index for example).

The following dimensions are used in the CGDR product files:

Table 7-1 Dimensions used in the CGDR data sets

Dimension Name	Value
time	Number of 1 Hz measurements in the file
samples	20 (number of elementary 18 Hz measurements within each 1 Hz average)

7.1.1.2 Variables

Variables are used to store the bulk of the data in a netCDF file. A variable represents an array of values of the same type. A scalar value is treated as a 0-dimensional array. A variable has a name, a data type, and a shape described by its list of dimensions specified when the variable is created. A variable may also have associated attributes, which may be added, deleted or changed after the variable is created.

A variable data type is one of a small set of netCDF types. In this document the variable types will be represented as follows:

Table 7-2 netCDF variable types

Variable type	Description
char	characters
byte	8-bit data signed
short	16-bit signed integer
int	32-bit signed integer
float	IEEE single precision floating point (32 bits)
double	IEEE double precision floating point (64 bits)



Table 7-3 Variables included in the CGDR products. Variables calculated or mapped to two dimensions by the COASTALT processor are shown in *italics*.

Variable	Variable type	Dimension
Coordinate and Auxiliary Coordinate Variables		
<i>time</i>	double	time
<i>samples</i>	short	samples
mdsr_time	double	time
<i>hz18_time</i>	double	time, samples
lat	int	time
lon	int	time
<i>hz18_lat</i>	int	time, samples
<i>hz18_lon</i>	int	time, samples
hz18_diff_1hz_lat	short	time, samples
hz18_diff_1hz_lon	short	time, samples
hz18_lat_diff	short	time, samples
hz18_lon_diff	short	time, samples
src_pack_cnt	int	time
<i>crs</i>	int	
Confidence Flags		
inst_mode_id_flags	int	time
meas_conf_data_flags	int	time
Orbit Information		
alt_cog_ellip	int	time
<i>hz18_alt_cog_ellip</i>	int	time, samples
hz18_diff_1hz_alt	short	time, samples
instant_alt_rate	short	time
Range Information		
hz18_ku_trk_cog	int	time, samples
hz18_s_trk_cog	int	time, samples
<i>map_18hz_ku_trk</i>	short	time, samples
ku_band_ocean_range	int	time
s_band_ocean_range	int	time
hz18_ku_band_ocean	int	time, samples
hz18_s_band_ocean	int	time, samples
sd_18hz_ku_ocean	short	time
sd_18hz_s_ocean	short	time
num_18hz_ku_ocean	short	time
num_18hz_s_ocean	short	time
<i>map_18hz_ku_ocean_flags</i>	short	time, samples
<i>map_18hz_s_ocean_flags</i>	short	time, samples

Variable	Variable type	Dimension
Range Correction Information		
hz18_ku_instr_corr	short	time, samples
hz18_s_instr_corr	short	time, samples
hz18_ku_dopp_corr	short	time, samples
hz18_s_dopp_corr	short	time, samples
hz18_ku_dopp_slp_corr	short	time, samples
hz18_s_dopp_slp_corr	short	time, samples
mod_dry_tropo_corr	short	time
inv_barom_corr	short	time
mod_wet_tropo_corr	short	time
mwr_wet_tropo_corr	short	time
ra2_ion_corr_ku	short	time
ra2_ion_corr_s	short	time
ion_corr_doris_ku	short	time
ion_corr_doris_s	short	time
ion_corr_mod_ku	short	time
ion_corr_mod_s	short	time
sea_bias_ku	short	time
sea_bias_s	short	time
dib_hf	short	time
Significant Wave Height Information		
ku_sig_wv_ht	short	time
s_sig_wv_ht	short	time
square_ku_sig_wv_ht	int	time
square_s_sig_wv_ht	int	time
sd_18hz_ku_swh	short	time
sd_18hz_s_swh	short	time
num_18hz_ku_ocean_swh	short	time
num_18hz_s_ocean_swh	short	time
<i>slp_mod_flags</i>	short	time, samples
elev_echo_pt	int	time
hz18_diff_mean_ech_pt	short	time, samples
Backscatter Information		
ku_ocean_bscat_coeff	short	time
s_ocean_bscat_coeff	short	time
sd_18hz_ku_ocean_bscat	short	time
sd_18hz_s_ocean_bscat	short	time
num_18hz_ku_ocean_bscat	short	time
num_18hz_s_ocean_bscat	short	time



Variable	Variable type	Dimension
hz18_k_cal_ku	short	time, samples
hz18_k_cal_s	short	time, samples
<i>map_18hz_k_cal_ku_flags</i>	int	time, samples
Backscatter Correction Information		
ku_net_instr_corr_agc	short	time
s_net_instr_corr_agc	short	time
ku_atm_atten_corr	short	time
s_atm_atten_corr	short	time
ku_rai_corr	int	time
Off-nadir Angle Information		
off_nad_ang_platf	short	time
off_nad_ang_wvform	short	time
Geophysical Information		
m_sea_surf_ht	int	time
geoid_ht	int	time
ocean_depland_elev	int	time
tot_geocen_ocn_tide_ht_sol1	short	time
tot_geocen_ocn_tide_ht_sol2	short	time
long_period_ocn_tide_ht	short	time
tidal_load_ht_sol1	short	time
tidal_load_ht_sol2	short	time
solid_earth_tide_ht	short	time
geocen_pole_tide_ht	short	time
mod_surf_atm_pres	short	time
mwr_wvapour_cont	short	time
mwr_liq_vapour_cont	short	time
ra2_elec_cont	short	time
ra2_wind_sp	short	time
mod_wind_sp_u	short	time
mod_wind_sp_v	short	time
MWR Information		
interpole_238_temp_mwr	short	time
interpole_365_temp_mwr	short	time
interpole_sd_238_temp_mwr	short	time
interpole_sd_365_temp_mwr	short	time
Flags and other Quality Information		
ave_ku_chirp	short	time
<i>ku_chirp_id_flags</i>	short	time, samples
<i>error_flag_chirp_id_flags</i>	int	time

Variable	Variable type	Dimension
<i>instr_flags</i>	int	time
<i>instr_id_data_level_flags</i>	short	time, samples
<i>num_meas_ku_calibr</i>	short	time
<i>num_meas_s_calibr</i>	short	time
<i>mwr_instr_flag</i>	short	time
<i>ku_ocean_retrk_qua_flags</i>	short	time, samples
<i>s_ocean_retrk_qua_flags</i>	short	time, samples
<i>ku_peak</i>	short	time
<i>s_peak</i>	short	time
<i>altim_landocean_flag</i>	short	time
<i>radio_landocean_flag</i>	short	time
<i>mwr_qua_interp_flag</i>	short	time
<i>rain_flag</i>	short	time
<i>interpole_flag</i>	short	time
New Brown Model Tracker Outputs		
<i>brown_range_ku</i>	double	time, samples
<i>brown_swh_ku</i>	double	time, samples
<i>brown_sigma0_ku</i>	double	time, samples
<i>brown_t0_ku</i>	double	time, samples
<i>brown_noise_ku</i>	double	time, samples
<i>gof_brown_ku</i>	double	time, samples
<i>brown_range_s</i>	double	time, samples
<i>brown_swh_s</i>	double	time, samples
<i>brown_sigma0_s</i>	double	time, samples
<i>brown_t0_s</i>	double	time, samples
<i>brown_noise_s</i>	double	time, samples
<i>gof_brown_s</i>	double	time, samples
Specular Tracker Outputs		
<i>spec_range_ku</i>	double	time, samples
<i>specular_beta4_ku</i>	double	time, samples
<i>specular_beta2_ku</i>	double	time, samples
<i>specular_beta3_ku</i>	double	time, samples
<i>specular_beta5_ku</i>	double	time, samples
<i>specular_beta1_ku</i>	double	time, samples
<i>gof_spec_ku</i>	double	time, samples
<i>spec_range_s</i>	double	time, samples
<i>specular_beta4_s</i>	double	time, samples
<i>specular_beta2_s</i>	double	time, samples
<i>specular_beta3_s</i>	double	time, samples



Variable	Variable type	Dimension
<i>specular_beta5_s</i>	double	time, samples
<i>specular_beta1_s</i>	double	time, samples
<i>gof_spec_s</i>	double	time, samples
Mixed Tracker Outputs		
<i>mixed_range_ku</i>	double	time, samples
<i>mixed_swh_ku</i>	double	time, samples
<i>mixed_sigma0_ku</i>	double	time, samples
<i>mixed_t0_ku</i>	double	time, samples
<i>mixed_beta4_ku</i>	double	time, samples
<i>mixed_beta2_ku</i>	double	time, samples
<i>mixed_beta3_ku</i>	double	time, samples
<i>mixed_beta5_ku</i>	double	time, samples
<i>mixed_noise_ku</i>	double	time, samples
<i>gof_mixed_ku</i>	double	time, samples
<i>mixed_range_s</i>	double	time, samples
<i>mixed_swh_s</i>	double	time, samples
<i>mixed_sigma0_s</i>	double	time, samples
<i>mixed_t0_s</i>	double	time, samples
<i>mixed_beta4_s</i>	double	time, samples
<i>mixed_beta2_s</i>	double	time, samples
<i>mixed_beta3_s</i>	double	time, samples
<i>mixed_beta5_s</i>	double	time, samples
<i>mixed_noise_s</i>	double	time, samples
<i>gof_mixed_s</i>	double	time, samples
New range corrections		
<i>uso_clock_correction</i>	int	time, samples
<i>hz18_dry_trop_mod</i>	short	time, samples
<i>hz18_inv_barom_corr</i>	short	time, samples
<i>HZ18_mod_wet_tropo_corr</i>	short	time, samples
<i>hz18_mwr_wet_trop</i>	short	time, samples
<i>hz18_ra2_iono_corr_ku</i>	short	time, samples
<i>hz18_ra2_iono_corr_s</i>	short	time, samples
<i>hz18_iono_corr_doris_ku</i>	short	time, samples
<i>hz18_iono_corr_doris_s</i>	short	time, samples
<i>hz18_iono_corr_mod_ku</i>	short	time, samples
<i>hz18_iono_corr_mod_s</i>	Short	time, samples
<i>iono_corr_brown_ku</i>	short	time, samples
<i>iono_corr_spec_ku</i>	short	time, samples
<i>iono_corr_mixed_ku</i>	short	time, samples

Variable	Variable type	Dimension
<i>hz18_sea_bias_ku</i>	short	time, samples
<i>hz18_sea_bias_s</i>	short	time, samples
<i>hz18_dib_hf</i>	short	time, samples
New geophysical corrections		
<i>hz18_m_sea_surf_ht</i>	int	time, samples
<i>hz18_geoid_ht</i>	int	time, samples
<i>hz18_ocean_depland_elev</i>	int	time, samples
<i>hz18_tot_geocen_ocn_tide_ht_sol1</i>	short	time, samples
<i>hz18_tot_geocen_ocn_tide_ht_sol2</i>	short	time, samples
<i>hz18_long_period_ocn_tide_ht</i>	short	time, samples
<i>hz18_tidal_load_ht_sol1</i>	short	time, samples
<i>hz18_tidal_load_ht_sol2</i>	short	time, samples
<i>hz18_solid_earth_tide_ht</i>	short	time, samples
<i>hz18_geocen_pole_tide_ht</i>	short	time, samples
New flags and quality indicators		
<i>coastalt_mask_flag</i>	short	time, samples
<i>distance_from_coast</i>	short	time, samples
<i>mwr_wet_trop_interp_flag</i>	short	time, samples

Table 7-4 Additional variables included in some limited region enhanced CGDR products.

Variable	Variable type	Dimension
<i>hz18_GPD_wet_tropo_corr</i>	double	time, samples
<i>hz18_GPD_interp_flag</i>	short	time, samples
<i>hz18_GPD_formal_error</i>	double	time, samples
<i>hz18_GPD_signal_variance</i>	double	time, samples

7.1.1.3 Coordinate variables and auxiliary coordinate variables

A variable with the same name as a dimension is called a **coordinate variable**. It typically defines a physical coordinate corresponding to that dimension. In accordance with the Climate and Forecast conventions, a coordinate variable is declared for each dimension. Missing values are not allowed in coordinate variables and they must be strictly monotonic. The two coordinate variables in the CGDR products are **time** and **samples**.

An **auxiliary coordinate variable** is a netCDF variable that contains coordinates data but is not a coordinate variable as defined above. Unlike coordinate variables, there is no relationship between the name of an auxiliary coordinate variable and the name(s) of its dimension(s). Typical auxiliary coordinate variables are latitude and longitude



7.1.1.4 Attributes

NetCDF attributes are used to store data about the data (ancillary data or metadata), similar in many ways to the information stored in data dictionaries and schema in conventional database systems. Most attributes provide information about a specific variable. These are identified by the name of that variable, together with the name of the attribute.

Some attributes provide information about the data set as a whole. They are called **global attributes** and contain similar information to that found in product headers for the Envisat level 2 format files. These attributes are defined in accordance with the CF-conventions (see §7.1.3).

The following table shows the variable attributes used in the CGDR product. There are no mandatory attributes and only attributes appropriate to each variable are assigned.

Table 7-5: Variable attributes

Attribute	Description
_FillValue	A value used to represent undefined or missing data
ancillary_variables	Identifies a variable that contains closely associated data, e.g., the measurement uncertainties of instrument data.
add_offset	If present, this number is to be added to the data after they are read by an application. If both scale_factor and add_offset attributes are present, the data are first scaled before the offset is added.
comment	Miscellaneous information about the data or the methods used to produce it
coordinates	Identified auxiliary coordinate variables.
flag_masks	Describe a number of independent Boolean conditions using bit field notation by setting unique bits in each flag_masks value. The flag_masks attribute is the same type as the variable to which it is attached, and contains a list of values matching unique bit fields. A flagged condition is identified by performing a bitwise AND of the variable value and each flag_masks value; a non-zero result indicates a true condition. Used in conjunction with flag_meanings.
flag_meanings	Use in conjunction with flag_values or flag_meanings to provide descriptive words or phrase for each flag value.
flag_values	Provide a list of the flag values. The flag_values attribute is the same type as the variable to which it is attached. Used in conjunction with flag_meanings.
institution	Institution which provides the data
long_name	A descriptive name that indicates a variable's content. This name is not standardized.
quality_flag	Name of the variable(s) (quality flag) representing the quality of the current variable
references	References that describe the data or methods used to produce it.
scale_factor	If present, the data are to be multiplied by this factor after the data are read by an application. See also add_offset attribute.
source	Data source (model features, or observation)
standard_name	A standard name that references a description of a variable's content in the CF standard name table.

7.1.2 The Common Data Language

The Common Data Language (CDL) is used to describe the content of a data set.

CDL is a human readable notation of the netCDF format. The netCDF utility **ncdump** converts netCDF binary objects to CDL text. The netCDF utility **ncgen** can create netCDF binary file from a CDL text file.

A CDL description of a NetCDF data set takes the form:

```
netcdf name {  
    dimension: ...  
    variables: ...  
    data: ...  
}
```

where the *name* is used only as a default in constructing file names by the ncgen utility. The value of name reported by ncdump is the filename of the netCDF binary source file. The CDL description consists of three optional parts, introduced by the keywords “dimensions”, “variables” and “data”. NetCDF dimension declarations appear after the dimensions keyword, netCDF variables and attributes are defined after the variables keyword and variable data assignments appear after the data keyword. CDL statements are terminated by a semicolon. Spaces, tabs and newlines can be used freely for readability. Comments in CDL follow the characters ‘//’ on any line.

Example:

```
netcdf example {  
    dimensions: // dimensions are declared first  
    time = 1000;
```

variables:

```
double time(time); // variable <type> <name>(<dimension>)  
    time:long_name = "time" ; // variable attributes  
    time:units = "seconds since 2000-01-01 00:00:00.0" ; //time is a coordinate variable.
```

```
int lon(time);  
    lon:long_name = "longitude" ;  
    lon:standard_name = "longitude" ;  
    lon:units = "degrees_east" ;  
    lon:scale_factor = 1.0e-06; //lon is an auxiliary coordinate variable
```

```
short altim_landocean_flag (time);  
    altim_landocean_flag:long_name = "Altimeter surface type flag" ;  
    altim_landocean_flag:FillValue = 127s;  
    altim_landocean_flag:flag_values = 0s, 1s, 2s, 3s;  
    altim_landocean_flag:flag_meanings = "ocean enclosed_seas_lakes continental_ice
```

land" ;

```
    altim_landocean_flag:coordinates = "lon lat" ;  
//altim_landocean_flag is a flag fully described by the flag_meanings and flag_values  
attributes:
```



```
//altim_landocean_flag = 0 -> ocean
//altim_landocean_flag = 1 -> enclosed seas or lakes
//altim_landocean_flag = 2 -> continental ice
//altim_landocean_flag = 3 -> land
//If altim_landocean_flag is not computed, it will take the value 127 (_FillValue attribute).
```

int alt_cog_ellip(time);

```
alt_cog_ellip:long_name = "Altitude of CoG above reference ellipsoid" ;
alt_cog_ellip:_FillValue = 2147483647 ;
alt_cog_ellip:units = "m" ;
alt_cog_ellip:add_offset = 8.0e+05;
alt_cog_ellip:scale_factor = 0.001;
alt_cog_ellip:coordinates = "lon lat" ;
```

//alt_cog_ellip is packed. The data are stored in 32-bit (long) integers. The value of the altitude of the satellite can be recovered using:

```
//alt_cog_ellip = (alt_cog_ellip(long) * scale_factor) + add_offset
```

7.1.3 CF convention

The Climate Forecast Conventions for netCDF are a set of ‘rules’ for describing climate related variables. They represent an agreed set of descriptions in terms of attributes and values that should be used to describe specific geophysical parameters. Variables names are not prescribed in the CF-conventions, however, the names of attributes and the values that some attributes can take, is defined.

7.2 Global attributes

Global attributes (the equivalent of Main Product Header and Specific Product Header parameters for SGDR products) may be displayed from a COASTALT CGDR data file using “**ncdump -h**” command.

A list (not necessarily exhaustive) of the global attributes available in the COASTALT CGDR is given below (attribute name and description).

Table 7-6 Global Attributes used in CGDR files

Attribute Name	Description
Conventions	netCDF convention followed. This attribute should be set to “CF-1.4” to indicate that the file is compliant with the Climate and Forecast netCDF convention
title	COASTALT : Envisat Coastal dataset
institution	Institution carrying out processing, e.g. NOCS
history	Creation: <date of creation> of COASTALT product
source	radar altimeter RA-2
product	COASTALT Product Name: Following the Envisat product naming convention from level 2 source data file
Processing Information	
Product_spec	Version of product specification document applicable to product

Attribute Name	Description
Product_ref	Reference documents for Product processing and handbook
Software_version	Version of L2 SGDR Software used to generate product
Proc_time	UTC time of L2 SGDR product generation
Product_revision	Version of COASTALT processor used to generate product
Data time and orbit information	
Sensing_start	UTC start time of data sensing for this pass
Sensing_stop	UTC stop time of data sensing for this pass
Phase	Phase letter
Cycle	Cycle number
Relative_orbit	Relative orbit number
Absolute_orbit	Absolute orbit number
Pass_number	Pass number from pole to pole
State_vector_time	UTC time of Envisat state vector
Delta_ut1	DUT1=UT1-UTC (s)
X_position	X Position in Earth-fixed reference (m)
Y_position	Y Position in Earth-fixed reference (m)
Z_position	Z Position in Earth-fixed reference (m)
X_velocity	X velocity in Earth-fixed reference ($m s^{-1}$)
Y_velocity	Y velocity in Earth-fixed reference ($m s^{-1}$)
Z_velocity	Z velocity in Earth-fixed reference ($m s^{-1}$)
Vector_source	Source of orbit vectors
Envisat_source	Source Envisat Level 2 product SPH Descriptor (RA2_MWR_SGDR)
Envisat_source_ref	Reference documents for Envisat L2 product Source
RA2_first_record_time	UTC Time of first record in this product
RA2_last_record_time	UTC Time of first record in this product
RA2_first_lat	Geodetic Latitude of the first record in this product (degrees N)
RA2_first_lon	Geodetic Longitude of the first record in this product (degrees E)
RA2_last_lat	Geodetic Latitude of the last record in this product (degrees N)
RA2_last_lon	Geodetic Longitude of the last record in this product (degrees E)
SBT to UTC Conversion Information	
UTC_SBT_time	UTC corresponding to SBT (currently defined to be given at the time of the ascending node state vector)
Sat_binary_time	Satellite binary time (SBT) 32 bit integer time of satellite clock
Clock_step	Clock step size (pico s)
Leap second information	
Leap_utc	UTC time of the occurrence of the leap second
Leap_sign	Leap second sign: +001 is positive, -001 if negative
Leap_err	Leap second error, 1 if leap second occurs within processing segment, 0 otherwise



Attribute Name	Description
Instrument Status Information	
RA2_flag_manoeuvre	Orbit manoeuvre indicator
RA2_MANOEUVRE_START_UTC	UTC of start of manoeuvre
RA2_MANOEUVRE_STOP_UTC	UTC of end of manoeuvre
RA2_RV_RFSS_DEF	Hardware configuration for RF subsystem (A or B)
RA2_RV_HPA_DEF	Hardware configuration for HPA subsystem (A or B)
RA-2 Processing Information	
RA2_TIME_SHIFT_MIDFRAME	Offset to apply to time tag to derive datation of the first waveform in a source packet <10-6s>
RA2_TIME_INTERVAL	Time interval between two waveforms <10-6s>
RA2_IF_MASK_SEL	IF Mask selection flag
RA2_IF_MASK_PROC	IF shape compensation processing mode
RA2_USO_SEL	USO selection flag
RA2_USO_PROC	USO compensation processing mode
RA2_CONFIGURATION_DATA	RA-2 Level 1B Configuration File
RA2_CHARACTERISATION_DATA	RA-2 Level 1B Characterisation Data File
USO_CORRECTION_DATA	USO Correction Data File
AVERAGE_GLOBAL_PRESSURE	Average of the global pressure over the ocean computed from the meteo field, the closest time to the first measurement. This field must be set to all zeros. <10Pa>
SOLAR_ACTIVITY_INDEX	Interpolated value for the solar activity index used for the first measurement
Reference Model Information	
METEO_MODEL_VERSION	Version of the meteorological model
DORIS_IONOSPHERIC_MODEL_VERSION	Version of the ionospheric model
Coastal_mask_version	Name of coastal mask file applied

7.3 Data Sets

The complete set of variables and attributes supplied in the CGDR files are specified in the current Product Specification Document [AD 7].

A complete list of variables and their attributes for any given CGDR file can be obtained using the “**ncdump -h**” command. This generates a CDL listing of the dimensions and variables, but not the data section of the netCDF file.

7.4 Software

This section lists some software that may be used to browse and use data from CGDR products.

7.4.1 Software provided with netCDF: “ncdump”

« ncdump » converts netCDF files to ASCII form (CDL)

See <http://www.unidata.ucar.edu/software/netcdf/docs/ncdump-man-1.html>.

The main options are:

- h Show only the header information in the output, that is the declarations of dimensions, variables, and attributes but no data values for any variables
 - c Show the values of coordinate variables (variables that are also dimensions) as well as the declarations of all dimensions, variables, and attribute values
 - v var1,...,varn The output will include data values for the specified variables, in addition to the declarations of all dimensions, variables, and attributes
 - x var1,...,varn Output XML (NcML) instead of CDL. The NcML does not include data values
-

7.4.2 netCDF Utilities

7.4.2.1 ncbrowse

ncBrowse is a Java application that provides flexible, interactive graphical displays of data and attributes from a wide range of netCDF data file conventions.

See <http://www.epic.noaa.gov/java/ncBrowse/>

7.4.2.2 netCDF Operator (NCO)

The netCDF Operators, or “NCO”, are a suite of programs known as **operators**. Each operator is a standalone, command line program which is executed at the UNIX shell-level, like, e.g., ls or mkdir. The operators take netCDF files as input, then perform a set of operations (e.g., deriving new data, averaging, hyperslabbing, or metadata manipulation) and produce a netCDF file as output. The operators are primarily designed to aid manipulation and analysis of gridded scientific data. The single command style of NCO allows users to manipulate and analyze files interactively and with simple scripts, avoiding the overhead (and some of the power) of a higher level programming environment.

See <http://nco.sourceforge.net/>

7.4.3 Specialist Altimetry Software : BRAT

The Basic Radar Altimetry Toolbox, BRAT, is a tool designed to use radar altimetry data. It is able:

- to read all altimetry data from official data centres, from ERS-1 and 2, Topex/Poseidon, Geosat Follow-on, Jason-1, Envisat, Jason-2 and Cryosat, from Sensor Geophysical Data Record to gridded merged data, including the COASTALT CGDR products
- to do some processing and computations
- to visualise the results

The Basic Radar Altimetry Toolbox can be divided in four main components:

- Data reading (also called "ingestion")
- Processing routine functions



-
- Visualisation functions
 - Graphic User Interface (GUI)

Alongside BRAT is a Radar Altimeter Tutorial (RAT), which provides an introduction and use cases for radar altimetry.

See http://www.altimetry.info/html/data/toolbox_en.html

Annexe A References

Applicable Documents

- AD 1 RA-2/MWR Product Handbook, Issue 2.2, 27 Feb 2007:
<http://envisat.esa.int/dataproducts/>
- AD 2 ENVISAT RA-2/MWR Level 2 User Manual, v1 rev.2, 20/06/2006
- AD 3 EnviSat-1 Product Specifications, ANNEX A: PRODUCT DATA CONVENTIONS PO-RS-MDA-GS-2009, Is.: 3, Rev.: D, Date: 05/05/2004
- AD 4 EnviSat-1 Product Specifications, Volume 5: RA-2 Product Structure PO-RS-MDA-GS-2009, Is.: 3, Rev.: D, Date: 22/11/2007
- AD 5 EnviSat-1 Product Specifications, Volume 14: RA-2 Product Specifications PO-RS-MDA-GS-2009, Is.: 4, Rev.: C, Date: 30/01/2009
- AD 6 COASTAL Waveform Retracker Software Technical Specifications. COASTALT STS001 v1.2, 28 July 2009.
- AD 7 COASTALT Product Specification v2.0 rev 3 12 July 2011.
- AD 8 Envisat RA2/MWR ocean data validation and cross-calibration activities. Yearly report 2009. CLS.DOS/NT/10.018 Issue 1 rev 1, June 30 2010.
- AD 9 [Envisat Altimetry Data Set Version 2.0] Level 1B and Level 2 processing upgrades. IDEAS-VEG-IPF-TSP-0543, Issue 1.1 2 Feb 2010.
- AD 10 COASTALT WP2 Technical Note Improvement of Corrections in Coastal Areas, NOCS report, 11 September 2008, 34pp.
- AD 11 COASTALT WP3.1 Technical Note Coastal waveform retracking: definition development and prototyping, U. Cádiz, 27pp.
- AD 12 Impact of the Envisat Mission Extension on SAR data, ESA Technical Note, revision 1.0, 12 October 2010
(http://earth.esa.int/pub/ESA_DOC/ENVISAT/Impact_of_Envisat_Mission_Extension_on_SAR_data_-_1_01.pdf)
- AD 13 Technical Note on Wet Tropospheric Corrections in Coastal Areas, COASTALT Deliverable 2.1b, v 1.2, 30 Jun 2009
- AD 14 Global assessment of GNSS-derived tropospheric corrections, COASTALT2 Deliverable 2.1a, COASTALT2-D21a-11, v 1.1, 26/07/2010
- AD 15 GPD output for CGDR for European coasts, COASTALT2 Deliverable 2.1b, COASTALT2-D21b-11, v 1.2, 08/02/2011.
- AD 16 COASTALT EWP1 – Deliverable D1.2a. Processor Improvements: Technical Note, , Version 1 25 July 2011.
- AD 17 COASTALT EWP1 – Deliverable D1.2b. Processor: Plug and Play User Guide COASTALT Processor – version 2.0 revision 3, Version 1 25 July 2011.
- AD 18 COASTALT Coastal Mask Tool – User Manual Version 1, ESA/ESRIN Contract No. 21201/08/I-LG Contract report



Reference Documents

- RD 1 Abdalla, S (2006). A wind retrieval algorithm for satellite radar altimeters. *ECMWF Technical Memorandum*.
- RD 2 Abramowitz, M and I M Stegun (1968). Handbook of mathematical functions with formulas, graphs, and mathematical tables. *Dover, N.Y.*, 1046pp.
- RD 3 Brenner, A C, C J Koblinsky and B D Beckley (1990). A Preliminary Estimate of Geoid-Induced Variations in Repeat Orbit Satellite Altimeter Observations. *Journal of Geophysical Research*, **95**(C3): 3033-3040.
- RD 4 Callahan, P S (1984). Ionospheric Variations affecting Altimeter Measurements: A brief synopsis. *Marine Geodesy*, **8**: 249-263.
- RD 5 Caballero, I, J Gómez-Enri, G Navarro and P Villares (2011). Towards a validation of ENVISAT RA-2 high rate significant wave height in coastal systems: case study of the Gulf of Cadiz. *5th EARSeL Workshop on Remote Sensing of the Coastal Zone, Prague, Czech Republic*, 1st – 3rd June, 2011
- RD 6 Carrère, L (2003). Etude et modélisation de la réponse haute fréquence de l’océan global aux forçage météorologiques. **PhD**.
Carrère, L and F Lyard (2003). Modelling the barotropic response of the global ocean to atmospheric wind and pressure forcing – comparisons with observations. *Geophysical Research Letters*, **30**(6): 1275.
- RD 7 Cartwright, D E, R D Ray and B V Sanchez (1991). Oceanic tide maps and spherical harmonic coefficients from Geosat altimetry. Goddard Space Flight Center. *NASA Tech. Memorandum*. **104544**: 74.
- RD 8 Cartwright, D E and R J Tayler (1971). New computations of the tide-generating potential. *Geophysical Journal of the Royal Astronomical Society*, **23**: 45-74.
Cartwright, D E and A C Edden (1973). Corrected tables of tidal harmonics. *Geophysical Journal of the Royal Astronomical Society*. **33**: 253-264.
- RD 9 Chambers, D P, B D Tapley and R H Stewart (1998). Reduction of geoid gradient error in ocean variability from satellite altimetry. *Marine Geodesy*, **21**: 25-40.
- RD 10 Chelton, D B, J C Ries, B J Haines, L-L Fu and P S Callahan (2001). Satellite Altimetry. In: *Satellite Altimetry and Earth Sciences*. L-L Fu and A Cazenave (Eds): 1-131.
- RD 11 CLS (2006). Design and assessment of a method to correct the Envisat RA-2 USO anomaly, *Contract rep. re contract ESA/Esrin 19049/05/I-OL*.
- RD 12 Deng, X and W E Featherstone (2006). A coastal retracking system for satellite radar altimeter waveforms: Application to ERS-2 around Australia. *Journal of Geophysical Research*, **111**(C06012), doi:10.1029/2005JC003039.
- RD 13 Defrenne, D and J Benveniste (2004). A global land elevation and ocean bathymetry model from radar altimetry. *QWG meeting minutes*.
- RD 14 Dumont, J P, V Rosmorduc, N Picot, S Desai, H Bonekamp, J Figa, J Lillibridge and R Scharroo (2009). OSTM/Jason-2 Products Handbook; Issue: 1 rev 4. *CNES Rep No. SALP-MU-M-OP-15815-CN*, August 3, 2009
- RD 15 Fernandes, M. J., C. Lázaro, A. L. Nunes, N. Pires, L. Bastos, V. B. Mendes, GNSS-derived Path Delay: an approach to compute the wet tropospheric correction for coastal altimetry, *IEEE Geosci. Rem. Sens Lett.*, vol. 7, no. 3, pp. 596–600. July 2010

- RD 16 Francis, O and P Mazzega (1990). Global charts of ocean tide loading effects. *Journal of Geophysical Research*, **95**: 11,411-11,424.
- RD 17 García Lafuente J and J Ruiz (2007). The Gulf of Cádiz pelagic ecosystem: A review. *Progress in Oceanography*, **74**(2-3): 228-251.
- RD 18 Gaspar, P and J P Florens (1998). Estimation of the sea state bias in radar altimeter measurements of sea level: Results from a new non parametric method. *Journal of Geophysical Research*, **103**: 15803-15814.
- Gaspar, P, S Labroue, F Ogor, G Lafitte, L Marchal and M Rafanel (2002). Improving non parametric estimates of the sea state bias in radar altimeter measurements of sea level. *Journal of Atmospheric and Oceanic Technology*, **19**: 1690-1707.
- RD 19 Gille S T & C W Hughes (2001). Aliasing of high-frequency variability by altimetry: Evaluation from bottom pressure recorders. *Geophysical Research Letters*, **28 (9)**: 1755-1758.
- RD 20 Gómez-Enri, J, C P Gommenginger, M A Srokosz, P G Challenor and J Benveniste (2007). Measuring global ocean wave skewness by retracking RA-2 ENVISAT waveforms. *Journal of Atmospheric and Oceanic Technology*, **24**: 1102 - 1116.
- RD 21 Hayne, O S (1980). Radar Altimeter Mean Return Waveforms from Near-Normal-Incidence Ocean Surface Scattering. *IEEE Transactions: Antennae and Propagation*, **AP-28**(5): 687-692.
- RD 22 Hernandez, F and P Schaeffer (2000). Altimetric Mean Sea Surfaces and Gravity Anomaly maps inter-comparisons. *CLS. AVI-NT-011-5242-CLS*: 48.
- Hernandez, F and P Schaeffer (2001). The CLS01 Mean Sea Surface: A validation with the GSFC00.1 surface. Secondary The CLS01 Mean Sea Surface: A validation with the GSFC00.1 surface. *Technical Report, CLS Ramonville St Agnes*: 14pp.
- RD 23 Imel, D (1994). Evaluation of the Topex/Poseidon dual-frequency ionosphere correction, *Journal of Geophysical Research*, **99**(24): 895-906, 1994
- RD 24 Labroue, S. and E. Obligis (2003). Neural network retrieval algorithm for the EnviSat/MWR. *CLS. ESA contract report (contract n° 13681/99/NL/GD). CLS/DOS/NT/03.848.*
- Labroue, S (2005). RA-2 Ocean and MWR measurement long term monitoring. *2005 report for WP3, Task2 SSB estimate for RA-2 altimeter. CLS_DOS-NT-05-200.*
- RD 25 Lefèvre, F, F H Lyard, C Le Provost and E J O Schrama (2002). FES99: a global tide finite element solution assimilating tide gauge and altimetric information. *Journal of Atmospheric and Oceanic Technology*, **19**: 1345-1356.
- Lefèvre, F (2002). Modélisation de la marée océanique à l'échelle globale par la méthode des éléments finis avec assimilation de données altimétriques. *CLS. SALP-RP-MA-E2-21060-CLS*: 87.
- Letellier, T, F Lyard and F Lefèvre (2004). The new global tidal solution: FES2004. *Ocean Surface Topography Science Team Meeting*, St. Petersburg, Florida.
- RD 26 Le Provost, C (2001). Ocean Tides. Satellite Altimetry and Earth Sciences. In: *Satellite Altimetry and Earth Sciences*. L-L Fu and A Cazenave (Eds): 267-303.
- RD 27 Le Provost, C, M . Genco, F Lyard, P Vincent and P Canceil (1995). Spectroscopy of the world ocean tides from a finite element hydrodynamic model. *Journal of Geophysical Research*, **99**: 24777-24797.



- RD 28 Lemoine, F G, S C Kenyon, K Factor, R G Trimmer, N K Pavlis, D S Chinn, C M Cox, S M Klosko, S B Luthcke, M H Torrence, Y M Wang, R G Williamson, R H Rapp and T R Olson (1998). The Development of the joint NASA GSFC and NIMA Geopotential Model EGM96. *NASA Goddard Space Flight Center. NASA/TP-1998-206861*.
- RD 29 Martini, A, P Feminias, G Alberti and M P Milagro-Perez (2005). RA-2 S-Band Anomaly: Detection and waveform reconstruction. *Proc. of 2004 Envisat & ERS Symposium, Salzburg, Austria. 6-10 September 2004 (ESA SP-572)*.
- RD 30 Pavlis, N and R H Rapp (1990). The development of an isostatic gravitational model to degree 360 and its use in global gravity modeling. *Geophysical Journal International*, **100**: 369-378.
- RD 31 Rapp, R H, R S Nerem, C K Shum, S M Klosko and R G Williamson (1991). Consideration of Permanent Tidal Deformation in the Orbit Determination and Data Analysis for the TOPEX/POSEIDON Mission. *Goddard Space Flight Center. NASA Tech. Memorandum. 100775*.
- RD 32 Rapp, R H, Y M Wang and N K Pavlis (1991). The Ohio State 1991 Geopotential and Sea Surface Topography Harmonic Coefficient Models. *Dept. of Geodetic Science and Surveying, The Ohio State University. 410*.
- RD 33 Ray, R D (1999). A global ocean tide model from TOPEX/POSEIDON altimetry: GOT99.2. Goddard Space Flight Center. *NASA Tech. Memorandum. 1999-209478*.
- RD 34 Ray, R D and B V Sanchez (1989). Radial deformation of the Earth by oceanic tidal loading. *Goddard Space Flight Center. NASA Tech. Memorandum. 100743*.
- RD 35 Rio, M-H and F.Hernandez (2004). A mean dynamic topography computed over the world ocean from altimetry, in situ measurements, and a geoid model. *Journal of Geophysical Research*, **109**(C12032).
- Rio, M-H, P Schaeffer, J-M Lemoine, and F Hernandez (2005). Estimation of the ocean Mean Dynamic Topography through the combination of altimetric data, in-situ measurements and GRACE geoid: From global to regional studies. *GOCINA international workshop, Luxembourg*.
- RD 36 Roblou L, F Lyard, . Le Hénaff and C Maraldi (2007): X-TRACK, A new processing tool for altimetry in coastal oceans. *Proc. ENVISAT Symposium, Montreux, Switzerland*.
- RD 37 Rodriguez, E, Y Kim and J M Martin (1992). The effect of small-wave modulation on the electromagnetic bias. *Journal of Geophysical Research*, **97**(C2): 2379-2389.
- RD 38 Smith, W H F and D T Sandwell (1994). Bathymetric prediction from dense satellite altimetry and sparse shipboard bathymetry. *Journal of Geophysical Research*, **99**: 21803-21824.
- RD 39 Stacey, F D (1977). *Physics of the Earth*. J. Wiley.
- RD 40 Stammer, D, C Wunsch and R m Ponte (2000). De-aliasing of global high frequency barotropic motions in altimeter observations. *Geophysical Research Letters*, **27**: 1175-1178.
- RD 41 Tierney, C, J Wahr, F Bryan and V Zlotnicki (2000). Short-period oceanic circulation: implications for satellite altimetry. *Geophysical Research Letters*, **27**: 1255-1258.
- RD 42 Tournadre, J and J C Morland (1998). The effects of rain on TOPEX/POSEIDON Altimeter data. *IEEE Trans. Geosci. Remote Sensing*, **35**: 1117-1135.
- RD 43 Wahr, J M (1985). Deformation Induced by Polar Motion. *Journal of Geophysical Research-Solid Earth and Planets*, **90**(B11): 9363-9368.

- RD 44 Wessel, P and W H F Smith (1996). A Global Self-consistent, Hierarchical, High-resolution Shoreline Database, *Journal of Geophysical Research*, **101**(B4): 8741-8743.
- RD 45 Witter, D L and D B Chelton (1991). A Geosat altimeter wind speed algorithm and a method for altimeter wind speed algorithm development. *Journal of Geophysical Research*, **96**: 8853-8860.
- RD 46 Wunsch, C (1972). Bermuda sea level in relation to tides, weather and baroclinic fluctuations. *Reviews Geophysics Space Physics*, **10**: 1-49.
- RD 47 Yi, Y (1995). Determination of Gridded Mean Sea Surface from TOPEX, ERS-1 and GEOSAT Altimeter Data. *Dept. of Geodetic Science and Surveying, The Ohio State University*. **434**: 9363-9368.



Annexe B List of acronyms

AATSR	Advanced Along Track Scanning Radiometer
AD	Applicable Document
AGC	Automatic Gain Control
ASAR	Advanced Synthetic Aperture Radar
ATSR	Along Track Scanning Radiometer
AVISO	Archivage, Validation et Interprétation des données des Satellites Océanographiques
BRAT	Basic Radar Altimetry Toolbox
CGDR	Coastal Geophysical Data Record
CLS	Collecte Localisation Satellites
COASTALT	ESA development of Coastal Altimetry
DORIS	Détermination d'Orbite et Radiopositionnement Intégrés par Satellite
DLM	Dynamically Linked Model
DTM	Digital Terrain Model
ECMWF	European Center for Medium range Weather Forecasting
EGM	Earth Gravity Model
EM	ElectroMagnetic
Envisat	Environmental Satellite
ESA	European Space Agency
FES	Finite Element Solution
GDR	Geophysical Data Records
GIM	Global Ionosphere Maps
GOMOS	Global Ozone Monitoring by Occultation of Stars
GNSS	Global Navigation Satellite System
GPD	GNSS-derived Path Delay
HF	High Frequency
IB	Inverse Barometer
IGDR	Interim Geophysical Data Records
LRR	Laser Retroreflector
JPL	Jet Propulsion Laboratory
MDT	Mean Dynamic Topography
MIPAS	Michelson Interferometer for Passive Atmospheric Sounding
MSS	Mean Sea Surface
NASA	National Aeronautics and Space Administration
NetCDF	Network Common Data Form
NOAA	National Oceanic and Atmospheric Administration
NOC	National Oceanography Centre
NOC-S	National Oceanography Centre, Southampton
NRT	Near Real Time
OSTST	Ocean Surface Topography Science Team



POD	Precision Orbit Determination
RA-2	Radar Altimeter-2
RD	Reference Document
RMS	Root Mean Square
SAR	Synthetic Aperture Radar
SCIAMACHY	SCanning Imaging Absorption SpectroMeter for Atmospheric Cartography
SGDR	Sensor Geophysical Data Record
SLA	Sea Level Anomaly
SLR	Satellite Laser Ranging
SSB	Sea State Bias
SSH	Sea Surface Height
SSHA	Sea Surface Height Anomaly
SWH	Significant Wave Height
TEC	Total Electron Content
USO	Ultra Stable Oscillator
UTC	Coordinated Universal Time



Annexe C Envisat 35-day Repeat Phase Pass Definitions

The tables in this Annexe provide the definitions of the passes within the Envisat 35-day repeat cycle phase (phase 2) in terms of their equator crossing longitude and equator crossing time (relative to the start of the cycle). The two tables provide the same information, but in the first instance the definitions are ordered by pass number (equivalent to time order) whilst in the second table, the passes are ordered by equator crossing longitude.

Table A-1 Equator Crossing Longitude and Time (in order of Pass Number)
(the longitudes are the average values for cycles 10 – 79)
(RO = Relative Orbit, P = Pass, D = Day Shift)

RO	Ascending Passes				Descending Passes				RO	Ascending Passes				Descending Passes			
	P	Long.	D	UTC	P	Long.	D	UTC		P	Long.	D	UTC	P	Long.	D	UTC
1	1	0.13	0	21:59:29	2	167.57	0	22:49:47	252	503	167.56	18	10:49:47	504	335.00	18	11:40:05
2	3	334.98	0	23:40:05	4	142.42	1	0:30:23	253	505	142.41	18	12:30:23	506	309.85	18	13:20:41
3	5	309.83	1	1:20:41	6	117.27	1	2:10:59	254	507	117.26	18	14:10:59	508	284.70	18	15:01:17
4	7	284.68	1	3:01:17	8	92.12	1	3:51:35	255	509	92.11	18	15:51:35	510	259.55	18	16:41:53
5	9	259.53	1	4:41:53	10	66.97	1	5:32:11	256	511	66.96	18	17:32:11	512	234.40	18	18:22:29
6	11	234.38	1	6:22:29	12	41.82	1	7:12:47	257	513	41.81	18	19:12:47	514	209.25	18	20:03:05
7	13	209.23	1	8:03:05	14	16.67	1	8:53:23	258	515	16.66	18	20:53:23	516	184.10	18	21:43:40
8	15	184.08	1	9:43:40	16	351.52	1	10:33:58	259	517	351.51	18	22:33:58	518	158.95	18	23:24:16
9	17	158.93	1	11:24:16	18	326.37	1	12:14:34	260	519	326.36	19	0:14:34	520	133.80	19	1:04:52
10	19	133.78	1	13:04:52	20	301.22	1	13:55:10	261	521	301.21	19	1:55:10	522	108.65	19	2:45:28
11	21	108.63	1	14:45:28	22	276.07	1	15:35:46	262	523	276.06	19	3:35:46	524	83.50	19	4:26:04
12	23	83.48	1	16:26:04	24	250.92	1	17:16:22	263	525	250.91	19	5:16:22	526	58.35	19	6:06:40
13	25	58.33	1	18:06:40	26	225.77	1	18:56:58	264	527	225.76	19	6:56:58	528	33.20	19	7:47:16
14	27	33.18	1	19:47:16	28	200.62	1	20:37:34	265	529	200.61	19	8:37:34	530	8.05	19	9:27:52
15	29	8.04	1	21:27:52	30	175.47	1	22:18:10	266	531	175.46	19	10:18:10	532	342.90	19	11:08:28
16	31	342.89	1	23:08:28	32	150.32	1	23:58:46	267	533	150.31	19	11:58:46	534	317.75	19	12:49:04
17	33	317.74	2	0:49:04	34	125.17	2	1:39:22	268	535	125.16	19	13:39:22	536	292.60	19	14:29:40
18	35	292.59	2	2:29:40	36	100.03	2	3:19:58	269	537	100.01	19	15:19:58	538	267.45	19	16:10:16
19	37	267.44	2	4:10:16	38	74.88	2	5:00:34	270	539	74.86	19	17:00:34	540	242.30	19	17:50:52
20	39	242.29	2	5:50:52	40	49.73	2	6:41:10	271	541	49.71	19	18:41:10	542	217.15	19	19:31:28
21	41	217.14	2	7:31:28	42	24.58	2	8:21:46	272	543	24.56	19	20:21:46	544	192.00	19	21:12:03
22	43	191.99	2	9:12:03	44	359.43	2	10:02:21	273	545	359.41	19	22:02:21	546	166.85	19	22:52:39
23	45	166.84	2	10:52:39	46	334.28	2	11:42:57	274	547	334.26	19	23:42:57	548	141.70	20	0:33:15
24	47	141.69	2	12:33:15	48	309.13	2	13:23:33	275	549	309.11	20	1:23:33	550	116.55	20	2:13:51
25	49	116.54	2	14:13:51	50	283.98	2	15:04:09	276	551	283.96	20	3:04:09	552	91.40	20	3:54:27
26	51	91.39	2	15:54:27	52	258.83	2	16:44:45	277	553	258.82	20	4:44:45	554	66.25	20	5:35:03
27	53	66.24	2	17:35:03	54	233.68	2	18:25:21	278	555	233.67	20	6:25:21	556	41.10	20	7:15:39
28	55	41.09	2	19:15:39	56	208.53	2	20:05:57	279	557	208.52	20	8:05:57	558	15.95	20	8:56:15
29	57	15.94	2	20:56:15	58	183.38	2	21:46:33	280	559	183.37	20	9:46:33	560	350.80	20	10:36:51
30	59	350.79	2	22:36:51	60	158.23	2	23:27:09	281	561	158.22	20	11:27:09	562	325.66	20	12:17:27
31	61	325.64	3	0:17:27	62	133.08	3	1:07:45	282	563	133.07	20	13:07:45	564	300.51	20	13:58:03
32	63	300.49	3	1:58:03	64	107.93	3	2:48:21	283	565	107.92	20	14:48:21	566	275.36	20	15:38:39
33	65	275.34	3	3:38:39	66	82.78	3	4:28:57	284	567	82.77	20	16:28:57	568	250.21	20	17:19:15
34	67	250.19	3	5:19:15	68	57.63	3	6:09:33	285	569	57.62	20	18:09:33	570	225.06	20	18:59:51
35	69	225.04	3	6:59:51	70	32.48	3	7:50:09	286	571	32.47	20	19:50:09	572	199.91	20	20:40:26
36	71	199.89	3	8:40:26	72	7.33	3	9:30:44	287	573	7.32	20	21:30:44	574	174.76	20	22:21:02
37	73	174.74	3	10:21:02	74	342.18	3	11:11:20	288	575	342.17	20	23:11:20	576	149.61	21	0:01:38
38	75	149.59	3	12:01:38	76	317.03	3	12:51:56	289	577	317.02	21	0:51:56	578	124.46	21	1:42:14
39	77	124.44	3	13:42:14	78	291.88	3	14:32:32	290	579	291.87	21	2:32:32	580	99.31	21	3:22:50
40	79	99.29	3	15:22:50	80	266.73	3	16:13:08	291	581	266.72	21	4:13:08	582	74.16	21	5:03:26
41	81	74.14	3	17:03:26	82	241.58	3	17:53:44	292	583	241.57	21	5:53:44	584	49.01	21	6:44:02
42	83	48.99	3	18:44:02	84	216.43	3	19:34:20	293	585	216.42	21	7:34:20	586	23.86	21	8:24:38
43	85	23.84	3	20:24:38	86	191.28	3	21:14:56	294	587	191.27	21	9:14:56	588	358.71	21	10:05:14
44	87	358.69	3	22:05:14	88	166.13	3	22:55:32	295	589	166.12	21	10:55:32	590	333.56	21	11:45:50
45	89	333.55	3	23:45:50	90	140.98	4	0:36:08	296	591	140.97	21	12:36:08	592	308.41	21	13:26:26
46	91	308.40	4	1:26:26	92	115.83	4	2:16:44	297	593	115.82	21	14:16:44	594	283.26	21	15:07:02
47	93	283.25	4	3:07:02	94	90.69	4	3:57:20	298	595	90.67	21	15:57:20	596	258.11	21	16:47:38
48	95	258.10	4	4:47:38	96	65.54	4	5:37:56	299	597	65.52	21	17:37:56	598	232.96	21	18:28:14
49	97	232.95	4	6:28:14	98	40.39	4	7:18:32	300	599	40.37	21	19:18:32	600	207.81	21	20:08:49
50	99	207.80	4	8:08:49	100	15.24	4	8:59:07	301	601	15.22	21	20:59:07	602	182.66	21	21:49:25
51	101	182.65	4	9:49:25	102	350.09	4	10:39:43	302	603	350.07	21	22:39:43	604	157.51	21	23:30:01
52	103	157.50	4	11:30:01	104	324.94	4	12:20:19	303	605	324.92	22	0:20:19	606	132.36	22	1:10:37
53	105	132.35	4	13:10:37	106	299.79	4	14:00:55	304	607	299.77	22	2:00:55	608	107.21	22	2:51:13
54	107	107.20	4	14:51:13	108	274.64	4	15:41:31	305	609	274.62	22	3:41:31	610	82.06	22	4:31:49
55	109	82.05	4	16:31:49	110	249.49	4	17:22:07	306	611	249.47	22	5:22:07	612	56.91	22	6:12:25
56	111	56.90	4	18:12:25	112	224.34	4	19:02:43	307	613	224.32	22	7:02:43	614	31.76	22	7:53:01
57	113	31.75	4	19:53:01	114	199.19	4	20:43:19	308	615	199.17	22	8:43:19	616	6.61	22	9:33:37
58	115	6.60	4	21:33:37	116	174.04	4	22:23:55	309	617	174.02	22	10:23:55	618	341.46	22	11:14:13
59	117	341.45	4	23:14:13	118	148.89	5	0:04:31	310	619	148.87	22	12:04:31	620	316.31	22	12:54:49
60	119	316.30	5	0:54:49	120	123.74	5	1:45:07	311	621	123.72	22	13:45:07	622	291.16	22	14:35:25



RO	Ascending Passes				Descending Passes				RO	Ascending Passes				Descending Passes			
	P	Long.	D	UTC	P	Long.	D	UTC		P	Long.	D	UTC	P	Long.	D	UTC
61	121	291.15	5	2:35:25	122	98.59	5	3:25:43	312	623	98.57	22	15:25:43	624	266.01	22	16:16:01
62	123	266.00	5	4:16:01	124	73.44	5	5:06:19	313	625	73.42	22	17:06:19	626	240.86	22	17:56:37
63	125	240.85	5	5:56:37	126	48.29	5	6:46:55	314	627	48.27	22	18:46:55	628	215.71	22	19:37:12
64	127	215.70	5	7:37:12	128	23.14	5	8:27:30	315	629	23.12	22	20:27:30	630	190.56	22	21:17:48
65	129	190.55	5	9:17:48	130	357.99	5	10:08:06	316	631	357.98	22	22:08:06	632	165.42	22	22:58:24
66	131	165.40	5	10:58:24	132	332.84	5	11:48:42	317	633	332.83	22	23:48:42	634	140.27	23	0:39:00
67	133	140.25	5	12:39:00	134	307.69	5	13:29:18	318	635	307.68	23	1:29:18	636	115.12	23	2:19:36
68	135	115.10	5	14:19:36	136	282.54	5	15:09:54	319	637	282.53	23	3:09:54	638	89.97	23	4:00:12
69	137	89.95	5	16:00:12	138	257.39	5	16:50:30	320	639	257.38	23	4:50:30	640	64.82	23	5:40:48
70	139	64.80	5	17:40:48	140	232.24	5	18:31:06	321	641	232.23	23	6:31:06	642	39.67	23	7:21:24
71	141	39.65	5	19:21:24	142	207.09	5	20:11:42	322	643	207.08	23	8:11:42	644	14.52	23	9:02:00
72	143	14.50	5	21:02:00	144	181.94	5	21:52:18	323	645	181.93	23	9:52:18	646	349.37	23	10:42:36
73	145	349.35	5	22:42:36	146	156.79	5	23:32:54	324	647	156.78	23	11:32:54	648	324.22	23	12:23:12
74	147	324.20	6	0:23:12	148	131.64	6	1:13:30	325	649	131.63	23	13:13:30	650	299.07	23	14:03:48
75	149	299.05	6	2:03:48	150	106.49	6	2:54:06	326	651	106.48	23	14:54:06	652	273.92	23	15:44:24
76	151	273.90	6	3:44:24	152	81.34	6	4:34:42	327	653	81.33	23	16:34:42	654	248.77	23	17:25:00
77	153	248.76	6	5:25:00	154	56.19	6	6:15:18	328	655	56.18	23	18:15:18	656	223.62	23	19:05:35
78	155	223.61	6	7:05:35	156	31.04	6	7:55:53	329	657	31.03	23	19:55:53	658	198.47	23	20:46:11
79	157	198.46	6	8:46:11	158	5.89	6	9:36:29	330	659	5.88	23	21:36:29	660	173.32	23	22:26:47
80	159	173.31	6	10:26:47	160	340.74	6	11:17:05	331	661	340.73	23	23:17:05	662	148.17	24	0:07:23
81	161	148.16	6	12:07:23	162	315.60	6	12:57:41	332	663	315.58	24	0:57:41	664	123.02	24	1:47:59
82	163	123.01	6	13:47:59	164	290.45	6	14:38:17	333	665	290.43	24	2:38:17	666	97.87	24	3:28:35
83	165	97.86	6	15:28:35	166	265.30	6	16:18:53	334	667	265.28	24	4:18:53	668	72.72	24	5:09:11
84	167	72.71	6	17:09:11	168	240.15	6	17:59:29	335	669	240.13	24	5:59:29	670	47.57	24	6:49:47
85	169	47.56	6	18:49:47	170	215.00	6	19:40:05	336	671	214.98	24	7:40:05	672	22.42	24	8:30:23
86	171	22.41	6	20:30:23	172	189.85	6	21:20:41	337	673	189.83	24	9:20:41	674	357.27	24	10:10:59
87	173	357.26	6	22:10:59	174	164.70	6	23:01:17	338	675	164.68	24	11:01:17	676	332.12	24	11:51:35
88	175	332.11	6	23:51:35	176	139.55	7	0:41:53	339	677	139.53	24	12:41:53	678	306.97	24	13:32:11
89	177	306.96	7	1:32:11	178	114.40	7	2:22:29	340	679	114.38	24	14:22:29	680	281.82	24	15:12:47
90	179	281.81	7	3:12:47	180	89.25	7	4:03:05	341	681	89.23	24	16:03:05	682	256.67	24	16:53:23
91	181	256.66	7	4:53:23	182	64.10	7	5:43:40	342	683	64.08	24	17:43:40	684	231.52	24	18:33:58
92	183	231.51	7	6:33:58	184	38.95	7	7:24:16	343	685	38.93	24	19:24:16	686	206.37	24	20:14:34
93	185	206.36	7	8:14:34	186	13.80	7	9:04:52	344	687	13.78	24	21:04:52	688	181.22	24	21:55:10
94	187	181.21	7	9:55:10	188	348.65	7	10:45:28	345	689	348.63	24	22:45:28	690	156.07	24	23:35:46
95	189	156.06	7	11:35:46	190	323.50	7	12:26:04	346	691	323.49	25	0:26:04	692	130.92	25	1:16:22
96	191	130.91	7	13:16:22	192	298.35	7	14:06:40	347	693	298.34	25	2:06:40	694	105.77	25	2:56:58
97	193	105.76	7	14:56:58	194	273.20	7	15:47:16	348	695	273.19	25	3:47:16	696	80.63	25	4:37:34
98	195	80.61	7	16:37:34	196	248.05	7	17:27:52	349	697	248.04	25	5:27:52	698	55.48	25	6:18:10
99	197	55.46	7	18:18:10	198	222.90	7	19:08:28	350	699	222.89	25	7:08:28	700	30.33	25	7:58:46
100	199	30.31	7	19:58:46	200	197.75	7	20:49:04	351	701	197.74	25	8:49:04	702	5.18	25	9:39:22
101	201	5.16	7	21:39:22	202	172.60	7	22:29:40	352	703	172.59	25	10:29:40	704	340.03	25	11:19:58
102	203	340.01	7	23:19:58	204	147.45	8	0:10:16	353	705	147.44	25	12:10:16	706	314.88	25	13:00:34
103	205	314.86	8	1:00:34	206	122.30	8	1:50:52	354	707	122.29	25	13:50:52	708	289.73	25	14:41:10
104	207	289.71	8	2:41:10	208	97.15	8	3:31:28	355	709	97.14	25	15:31:28	710	264.58	25	16:21:46
105	209	264.56	8	4:21:46	210	72.00	8	5:12:03	356	711	71.99	25	17:12:03	712	239.43	25	18:02:21
106	211	239.41	8	6:02:21	212	46.85	8	6:52:39	357	713	46.84	25	18:52:39	714	214.28	25	19:42:57
107	213	214.26	8	7:42:57	214	21.70	8	8:33:15	358	715	21.69	25	20:33:15	716	189.13	25	21:23:33
108	215	189.11	8	9:23:33	216	356.55	8	10:13:51	359	717	356.54	25	22:13:51	718	163.98	25	23:04:09
109	217	163.96	8	11:04:09	218	331.40	8	11:54:27	360	719	331.39	25	23:54:27	720	138.83	26	0:44:45
110	219	138.81	8	12:44:45	220	306.25	8	13:35:03	361	721	306.24	26	1:35:03	722	113.68	26	2:25:21
111	221	113.66	8	14:25:21	222	281.10	8	15:15:39	362	723	281.09	26	3:15:39	724	88.53	26	4:05:57
112	223	88.51	8	16:05:57	224	255.95	8	16:56:15	363	725	255.94	26	4:56:15	726	63.38	26	5:46:33
113	225	63.36	8	17:46:33	226	230.80	8	18:36:51	364	727	230.79	26	6:36:51	728	38.23	26	7:27:09
114	227	38.21	8	19:27:09	228	205.65	8	20:17:27	365	729	205.64	26	8:17:27	730	13.08	26	9:07:45
115	229	13.07	8	21:07:45	230	180.50	8	21:58:03	366	731	180.49	26	9:58:03	732	347.93	26	10:48:21
116	231	347.92	8	22:48:21	232	155.36	8	23:38:39	367	733	155.34	26	11:38:39	734	322.78	26	12:28:57
117	233	322.77	9	0:28:57	234	130.21	9	1:19:15	368	735	130.19	26	13:19:15	736	297.63	26	14:09:33
118	235	297.62	9	2:09:33	236	105.06	9	2:59:51	369	737	105.04	26	14:59:51	738	272.48	26	15:50:09
119	237	272.47	9	3:50:09	238	79.91	9	4:40:26	370	739	79.89	26	16:40:26	740	247.33	26	17:30:44
120	239	247.32	9	5:30:44	240	54.76	9	6:21:02	371	741	54.74	26	18:21:02	742	222.18	26	19:11:20
121	241	222.17	9	7:11:20	242	29.61	9	8:01:38	372	743	29.59	26	20:01:38	744	197.03	26	20:51:56
122	243	197.02	9	8:51:56	244	4.46	9	9:42:14	373	745	4.44	26	21:42:14	746	171.88	26	22:32:32
123	245	171.87	9	10:32:32	246	339.31	9	11:22:50	374	747	339.29	26	23:22:50	748	146.73	27	0:13:08
124	247	146.72	9	12:13:08	248	314.16	9	13:03:26	375	749	314.14	27	1:03:26	750	121.58	27	1:53:44



RO	Ascending Passes				Descending Passes				RO	Ascending Passes				Descending Passes			
	P	Long.	D	UTC	P	Long.	D	UTC		P	Long.	D	UTC	P	Long.	D	UTC
125	249	121.57	9	13:53:44	250	289.01	9	14:44:02	376	751	288.99	27	2:44:02	752	96.43	27	3:34:20
126	251	96.42	9	15:34:20	252	263.86	9	16:24:38	377	753	263.85	27	4:24:38	754	71.28	27	5:14:56
127	253	71.27	9	17:14:56	254	238.71	9	18:05:14	378	755	238.70	27	6:05:14	756	46.13	27	6:55:32
128	255	46.12	9	18:55:32	256	213.56	9	19:45:50	379	757	213.55	27	7:45:50	758	20.98	27	8:36:08
129	257	20.97	9	20:36:08	258	188.41	9	21:26:26	380	759	188.40	27	9:26:26	760	355.83	27	10:16:44
130	259	355.82	9	22:16:44	260	163.26	9	23:07:02	381	761	163.25	27	11:07:02	762	330.69	27	11:57:20
131	261	330.67	9	23:57:20	262	138.11	10	0:47:38	382	763	138.10	27	12:47:38	764	305.54	27	13:37:56
132	263	305.52	10	1:37:56	264	112.96	10	2:28:14	383	765	112.95	27	14:28:14	766	280.39	27	15:18:32
133	265	280.37	10	3:18:32	266	87.81	10	4:08:49	384	767	87.80	27	16:08:49	768	255.24	27	16:59:07
134	267	255.22	10	4:59:07	268	62.66	10	5:49:25	385	769	62.65	27	17:49:25	770	230.09	27	18:39:43
135	269	230.07	10	6:39:43	270	37.51	10	7:30:01	386	771	37.50	27	19:30:01	772	204.94	27	20:20:19
136	271	204.92	10	8:20:19	272	12.36	10	9:10:37	387	773	12.35	27	21:10:37	774	179.79	27	22:00:55
137	273	179.77	10	10:00:55	274	347.21	10	10:51:13	388	775	347.20	27	22:51:13	776	154.64	27	23:41:31
138	275	154.62	10	11:41:31	276	322.06	10	12:31:49	389	777	322.05	28	0:31:49	778	129.49	28	1:22:07
139	277	129.47	10	13:22:07	278	296.91	10	14:12:25	390	779	296.90	28	2:12:25	780	104.34	28	3:02:43
140	279	104.32	10	15:02:43	280	271.76	10	15:53:01	391	781	271.75	28	3:53:01	782	79.19	28	4:43:19
141	281	79.17	10	16:43:19	282	246.61	10	17:33:37	392	783	246.60	28	5:33:37	784	54.04	28	6:23:55
142	283	54.02	10	18:23:55	284	221.46	10	19:14:13	393	785	221.45	28	7:14:13	786	28.89	28	8:04:31
143	285	28.87	10	20:04:31	286	196.31	10	20:54:49	394	787	196.30	28	8:54:49	788	3.74	28	9:45:07
144	287	3.72	10	21:45:07	288	171.16	10	22:35:25	395	789	171.15	28	10:35:25	790	338.59	28	11:25:43
145	289	338.58	10	23:25:43	290	146.01	11	0:16:01	396	791	146.00	28	12:16:01	792	313.44	28	13:06:19
146	291	313.43	11	1:06:19	292	120.86	11	1:56:37	397	793	120.85	28	13:56:37	794	288.29	28	14:46:55
147	293	288.28	11	2:46:55	294	95.72	11	3:37:12	398	795	95.70	28	15:37:12	796	263.14	28	16:27:30
148	295	263.13	11	4:27:30	296	70.57	11	5:17:48	399	797	70.55	28	17:17:48	798	237.99	28	18:08:06
149	297	237.98	11	6:08:06	298	45.42	11	6:58:24	400	799	45.40	28	18:58:24	800	212.84	28	19:48:42
150	299	212.83	11	7:48:42	300	20.27	11	8:39:00	401	801	20.25	28	20:39:00	802	187.69	28	21:29:18
151	301	187.68	11	9:29:18	302	355.12	11	10:19:36	402	803	355.10	28	22:19:36	804	162.54	28	23:09:54
152	303	162.53	11	11:09:54	304	329.97	11	12:00:12	403	805	329.95	29	0:00:12	806	137.39	29	0:50:30
153	305	137.38	11	12:50:30	306	304.82	11	13:40:48	404	807	304.80	29	1:40:48	808	112.24	29	2:31:06
154	307	112.23	11	14:31:06	308	279.67	11	15:21:24	405	809	279.65	29	3:21:24	810	87.09	29	4:11:42
155	309	87.08	11	16:11:42	310	254.52	11	17:02:00	406	811	254.50	29	5:02:00	812	61.94	29	5:52:18
156	311	61.93	11	17:52:18	312	229.37	11	18:42:36	407	813	229.35	29	6:42:36	814	36.79	29	7:32:54
157	313	36.78	11	19:32:54	314	204.22	11	20:23:12	408	815	204.20	29	8:23:12	816	11.64	29	9:13:30
158	315	11.63	11	21:13:30	316	179.07	11	22:03:48	409	817	179.05	29	10:03:48	818	346.49	29	10:54:06
159	317	346.48	11	22:54:06	318	153.92	11	23:44:24	410	819	153.90	29	11:44:24	820	321.34	29	12:34:42
160	319	321.33	12	0:34:42	320	128.77	12	1:25:00	411	821	128.75	29	13:25:00	822	296.19	29	14:15:18
161	321	296.18	12	2:15:18	322	103.62	12	3:05:35	412	823	103.60	29	15:05:35	824	271.04	29	15:55:53
162	323	271.03	12	3:55:53	324	78.47	12	4:46:11	413	825	78.45	29	16:46:11	826	245.89	29	17:36:29
163	325	245.88	12	5:36:29	326	53.32	12	6:26:47	414	827	53.30	29	18:26:47	828	220.74	29	19:17:05
164	327	220.73	12	7:17:05	328	28.17	12	8:07:23	415	829	28.15	29	20:07:23	830	195.59	29	20:57:41
165	329	195.58	12	8:57:41	330	3.02	12	9:47:59	416	831	3.01	29	21:47:59	832	170.45	29	22:38:17
166	331	170.43	12	10:38:17	332	337.87	12	11:28:35	417	833	337.86	29	23:28:35	834	145.30	30	0:18:53
167	333	145.28	12	12:18:53	334	312.72	12	13:09:11	418	835	312.71	30	1:09:11	836	120.15	30	1:59:29
168	335	120.13	12	13:59:29	336	287.57	12	14:49:47	419	837	287.56	30	2:49:47	838	95.00	30	3:40:05
169	337	94.98	12	15:40:05	338	262.42	12	16:30:23	420	839	262.41	30	4:30:23	840	69.85	30	5:20:41
170	339	69.83	12	17:20:41	340	237.27	12	18:10:59	421	841	237.26	30	6:10:59	842	44.70	30	7:01:17
171	341	44.68	12	19:01:17	342	212.12	12	19:51:35	422	843	212.11	30	7:51:35	844	19.55	30	8:41:53
172	343	19.53	12	20:41:53	344	186.97	12	21:32:11	423	845	186.96	30	9:32:11	846	354.40	30	10:22:29
173	345	354.38	12	22:22:29	346	161.82	12	23:12:47	424	847	161.81	30	11:12:47	848	329.25	30	12:03:05
174	347	329.23	13	0:03:05	348	136.67	13	0:53:23	425	849	136.66	30	12:53:23	850	304.10	30	13:43:40
175	349	304.08	13	1:43:40	350	111.52	13	2:33:58	426	851	111.51	30	14:33:58	852	278.95	30	15:24:16
176	351	278.93	13	3:24:16	352	86.37	13	4:14:34	427	853	86.36	30	16:14:34	854	253.80	30	17:04:52
177	353	253.79	13	5:04:52	354	61.22	13	5:55:10	428	855	61.21	30	17:55:10	856	228.65	30	18:45:28
178	355	228.64	13	6:45:28	356	36.07	13	7:35:46	429	857	36.06	30	19:35:46	858	203.50	30	20:26:04
179	357	203.49	13	8:26:04	358	10.92	13	9:16:22	430	859	10.91	30	21:16:22	860	178.35	30	22:06:40
180	359	178.34	13	10:06:40	360	345.77	13	10:56:58	431	861	345.76	30	22:56:58	862	153.20	30	23:47:16
181	361	153.19	13	11:47:16	362	320.62	13	12:37:34	432	863	320.61	31	0:37:34	864	128.05	31	1:27:52
182	363	128.04	13	13:27:52	364	295.48	13	14:18:10	433	865	295.46	31	2:18:10	866	102.90	31	3:08:28
183	365	102.89	13	15:08:28	366	270.33	13	15:58:46	434	867	270.31	31	3:58:46	868	77.75	31	4:49:04
184	367	77.74	13	16:49:04	368	245.17	13	17:39:22	435	869	245.16	31	5:39:22	870	52.60	31	6:29:40
185	369	52.59	13	18:29:40	370	220.02	13	19:19:58	436	871	220.01	31	7:19:58	872	27.45	31	8:10:16
186	371	27.44	13	20:10:16	372	194.88	13	21:00:34	437	873	194.86	31	9:00:34	874	2.30	31	9:50:52
187	373	2.29	13	21:50:52	374	169.73	13	22:41:10	438	875	169.71	31	10:41:10	876	337.15	31	11:31:28
188	375	337.14	13	23:31:28	376	144.58	14	0:21:46	439	877	144.56	31	12:21:46	878	312.00	31	13:12:03



RO	Ascending Passes				Descending Passes				RO	Ascending Passes				Descending Passes			
	P	Long.	D	UTC	P	Long.	D	UTC		P	Long.	D	UTC	P	Long.	D	UTC
189	377	311.99	14	1:12:03	378	119.43	14	2:02:21	440	879	119.41	31	14:02:21	880	286.85	31	14:52:39
190	379	286.84	14	2:52:39	380	94.28	14	3:42:57	441	881	94.26	31	15:42:57	882	261.70	31	16:33:15
191	381	261.69	14	4:33:15	382	69.13	14	5:23:33	442	883	69.11	31	17:23:33	884	236.55	31	18:13:51
192	383	236.54	14	6:13:51	384	43.98	14	7:04:09	443	885	43.96	31	19:04:09	886	211.40	31	19:54:27
193	385	211.39	14	7:54:27	386	18.83	14	8:44:45	444	887	18.81	31	20:44:45	888	186.25	31	21:35:03
194	387	186.24	14	9:35:03	388	353.68	14	10:25:21	445	889	353.66	31	22:25:21	890	161.10	31	23:15:39
195	389	161.09	14	11:15:39	390	328.53	14	12:05:57	446	891	328.52	32	0:05:57	892	135.95	32	0:56:15
196	391	135.94	14	12:56:15	392	303.38	14	13:46:33	447	893	303.37	32	1:46:33	894	110.80	32	2:36:51
197	393	110.79	14	14:36:51	394	278.23	14	15:27:09	448	895	278.22	32	3:27:09	896	85.66	32	4:17:27
198	395	85.64	14	16:17:27	396	253.08	14	17:07:45	449	897	253.07	32	5:07:45	898	60.51	32	5:58:03
199	397	60.49	14	17:58:03	398	227.93	14	18:48:21	450	899	227.92	32	6:48:21	900	35.36	32	7:38:39
200	399	35.34	14	19:38:39	400	202.78	14	20:28:57	451	901	202.77	32	8:28:57	902	10.21	32	9:19:15
201	401	10.19	14	21:19:15	402	177.63	14	22:09:33	452	903	177.62	32	10:09:33	904	345.06	32	10:59:51
202	403	345.04	14	22:59:51	404	152.48	14	23:50:09	453	905	152.47	32	11:50:09	906	319.91	32	12:40:26
203	405	319.89	15	0:40:26	406	127.33	15	1:30:44	454	907	127.32	32	13:30:44	908	294.76	32	14:21:02
204	407	294.74	15	2:21:02	408	102.18	15	3:11:20	455	909	102.17	32	15:11:20	910	269.61	32	16:01:38
205	409	269.59	15	4:01:38	410	77.03	15	4:51:56	456	911	77.02	32	16:51:56	912	244.46	32	17:42:14
206	411	244.44	15	5:42:14	412	51.88	15	6:32:32	457	913	51.87	32	18:32:32	914	219.31	32	19:22:50
207	413	219.29	15	7:22:50	414	26.73	15	8:13:08	458	915	26.72	32	20:13:08	916	194.16	32	21:03:26
208	415	194.14	15	9:03:26	416	1.58	15	9:53:44	459	917	1.57	32	21:53:44	918	169.01	32	22:44:02
209	417	168.99	15	10:44:02	418	336.43	15	11:34:20	460	919	336.42	32	23:34:20	920	143.86	33	0:24:38
210	419	143.84	15	12:24:38	420	311.28	15	13:14:56	461	921	311.27	33	1:14:56	922	118.71	33	2:05:14
211	421	118.70	15	14:05:14	422	286.13	15	14:55:32	462	923	286.12	33	2:55:32	924	93.56	33	3:45:50
212	423	93.54	15	15:45:50	424	260.98	15	16:36:08	463	925	260.97	33	4:36:08	926	68.41	33	5:26:26
213	425	68.39	15	17:26:26	426	235.83	15	18:16:44	464	927	235.82	33	6:16:44	928	43.26	33	7:07:02
214	427	43.24	15	19:07:02	428	210.68	15	19:57:20	465	929	210.67	33	7:57:20	930	18.11	33	8:47:38
215	429	18.09	15	20:47:38	430	185.53	15	21:37:56	466	931	185.52	33	9:37:56	932	352.96	33	10:28:14
216	431	352.95	15	22:28:14	432	160.38	15	23:18:32	467	933	160.37	33	11:18:32	934	327.81	33	12:08:49
217	433	327.80	16	0:08:49	434	135.23	16	0:59:07	468	935	135.22	33	12:59:07	936	302.66	33	13:49:25
218	435	302.65	16	1:49:25	436	110.09	16	2:39:43	469	937	110.07	33	14:39:43	938	277.51	33	15:30:01
219	437	277.50	16	3:30:01	438	84.94	16	4:20:19	470	939	84.92	33	16:20:19	940	252.36	33	17:10:37
220	439	252.35	16	5:10:37	440	59.79	16	6:00:55	471	941	59.77	33	18:00:55	942	227.21	33	18:51:13
221	441	227.20	16	6:51:13	442	34.64	16	7:41:31	472	943	34.62	33	19:41:31	944	202.06	33	20:31:49
222	443	202.05	16	8:31:49	444	9.49	16	9:22:07	473	945	9.47	33	21:22:07	946	176.91	33	22:12:25
223	445	176.90	16	10:12:25	446	344.34	16	11:02:43	474	947	344.32	33	23:02:43	948	151.76	33	23:53:01
224	447	151.75	16	11:53:01	448	319.19	16	12:43:19	475	949	319.17	34	0:43:19	950	126.61	34	1:33:37
225	449	126.60	16	13:33:37	450	294.04	16	14:23:55	476	951	294.02	34	2:23:55	952	101.46	34	3:14:13
226	451	101.45	16	15:14:13	452	268.89	16	16:04:31	477	953	268.87	34	4:04:31	954	76.31	34	4:54:49
227	453	76.30	16	16:54:49	454	243.74	16	17:45:07	478	955	243.73	34	5:45:07	956	51.16	34	6:35:25
228	455	51.15	16	18:35:25	456	218.59	16	19:25:43	479	957	218.58	34	7:25:43	958	26.01	34	8:16:01
229	457	26.00	16	20:16:01	458	193.44	16	21:06:19	480	959	193.43	34	9:06:19	960	0.86	34	9:56:37
230	459	0.85	16	21:56:37	460	168.29	16	22:46:55	481	961	168.28	34	10:46:55	962	335.72	34	11:37:12
231	461	335.70	16	23:37:12	462	143.14	17	0:27:30	482	963	143.13	34	12:27:30	964	310.57	34	13:17:48
232	463	310.55	17	1:17:48	464	117.99	17	2:08:06	483	965	117.98	34	14:08:06	966	285.42	34	14:58:24
233	465	285.40	17	2:58:24	466	92.84	17	3:48:42	484	967	92.83	34	15:48:42	968	260.27	34	16:39:00
234	467	260.25	17	4:39:00	468	67.69	17	5:29:18	485	969	67.68	34	17:29:18	970	235.12	34	18:19:36
235	469	235.10	17	6:19:36	470	42.54	17	7:09:54	486	971	42.53	34	19:09:54	972	209.97	34	20:00:12
236	471	209.95	17	8:00:12	472	17.39	17	8:50:30	487	973	17.38	34	20:50:30	974	184.82	34	21:40:48
237	473	184.80	17	9:40:48	474	352.24	17	10:31:06	488	975	352.23	34	22:31:06	976	159.67	34	23:21:24
238	475	159.65	17	11:21:24	476	327.09	17	12:11:42	489	977	327.08	35	0:11:42	978	134.52	35	1:02:00
239	477	134.50	17	13:02:00	478	301.94	17	13:52:18	490	979	301.93	35	1:52:18	980	109.37	35	2:42:36
240	479	109.35	17	14:42:36	480	276.79	17	15:32:54	491	981	276.78	35	3:32:54	982	84.22	35	4:23:12
241	481	84.20	17	16:23:12	482	251.64	17	17:13:30	492	983	251.63	35	5:13:30	984	59.07	35	6:03:48
242	483	59.05	17	18:03:48	484	226.49	17	18:54:06	493	985	226.48	35	6:54:06	986	33.92	35	7:44:24
243	485	33.90	17	19:44:24	486	201.34	17	20:34:42	494	987	201.33	35	8:34:42	988	8.77	35	9:25:00
244	487	8.75	17	21:25:00	488	176.19	17	22:15:18	495	989	176.18	35	10:15:18	990	343.62	35	11:05:35
245	489	343.61	17	23:05:35	490	151.04	17	23:55:53	496	991	151.03	35	11:55:53	992	318.47	35	12:46:11
246	491	318.46	18	0:46:11	492	125.89	18	1:36:29	497	993	125.88	35	13:36:29	994	293.32	35	14:26:47
247	493	293.31	18	2:26:47	494	100.75	18	3:17:05	498	995	100.73	35	15:17:05	996	268.17	35	16:07:23
248	495	268.16	18	4:07:23	496	75.60	18	4:57:41	499	997	75.58	35	16:57:41	998	243.02	35	17:47:59
249	497	243.01	18	5:47:59	498	50.45	18	6:38:17	500	999	50.43	35	18:38:17	1000	217.87	35	19:28:35
250	499	217.86	18	7:28:35	500	25.30	18	8:18:53	501	1001	25.28	35	20:18:53	1002	192.72	35	21:09:11
251	501	192.71	18	9:09:11	502	0.15	18	9:59:29									

**Table A-2 Equator Crossing Longitude and Time (in order of Longitude)
(the longitudes are the average values for cycles 10 – 79)
(RO = Relative Orbit, P = Pass, D = Day Shift)**

RO	Ascending Passes				Descending Passes				RO	Ascending Passes				Descending Passes			
	P	Long.	D	UTC	P	Long.	D	UTC		P	Long.	D	UTC	P	Long.	D	UTC
1	1	0.13	0	21:59:29	2	167.57	0	22:49:47	366	731	180.49	26	9:58:03	732	347.93	26	10:48:21
230	459	0.85	16	21:56:37	460	168.29	16	22:46:55	94	187	181.21	7	9:55:10	188	348.65	7	10:45:28
459	917	1.57	32	21:53:44	918	169.01	32	22:44:02	323	645	181.93	23	9:52:18	646	349.37	23	10:42:36
187	373	2.29	13	21:50:52	374	169.73	13	22:41:10	51	101	182.65	4	9:49:25	102	350.09	4	10:39:43
416	831	3.01	29	21:47:59	832	170.45	29	22:38:17	280	559	183.37	20	9:46:33	560	350.80	20	10:36:51
144	287	3.72	10	21:45:07	288	171.16	10	22:35:25	8	15	184.08	1	9:43:40	16	351.52	1	10:33:58
373	745	4.44	26	21:42:14	746	171.88	26	22:32:32	237	473	184.80	17	9:40:48	474	352.24	17	10:31:06
101	201	5.16	7	21:39:22	202	172.60	7	22:29:40	466	931	185.52	33	9:37:56	932	352.96	33	10:28:14
330	659	5.88	23	21:36:29	660	173.32	23	22:26:47	194	387	186.24	14	9:35:03	388	353.68	14	10:25:21
58	115	6.60	4	21:33:37	116	174.04	4	22:23:55	423	845	186.96	30	9:32:11	846	354.40	30	10:22:29
287	573	7.32	20	21:30:44	574	174.76	20	22:21:02	151	301	187.68	11	9:29:18	302	355.12	11	10:19:36
15	29	8.04	1	21:27:52	30	175.47	1	22:18:10	380	759	188.40	27	9:26:26	760	355.83	27	10:16:44
244	487	8.75	17	21:25:00	488	176.19	17	22:15:18	108	215	189.11	8	9:23:33	216	356.55	8	10:13:51
473	945	9.47	33	21:22:07	946	176.91	33	22:12:25	337	673	189.83	24	9:20:41	674	357.27	24	10:10:59
201	401	10.19	14	21:19:15	402	177.63	14	22:09:33	65	129	190.55	5	9:17:48	130	357.99	5	10:08:06
430	859	10.91	30	21:16:22	860	178.35	30	22:06:40	294	587	191.27	21	9:14:56	588	358.71	21	10:05:14
158	315	11.63	11	21:13:30	316	179.07	11	22:03:48	22	43	191.99	2	9:12:03	44	359.43	2	10:02:21
387	773	12.35	27	21:10:37	774	179.79	27	22:00:55	251	501	192.71	18	9:09:11	502	0.15	18	9:59:29
115	229	13.07	8	21:07:45	230	180.50	8	21:58:03	480	959	193.43	34	9:06:19	960	0.86	34	9:56:37
344	687	13.78	24	21:04:52	688	181.22	24	21:55:10	208	415	194.14	15	9:03:26	416	1.58	15	9:53:44
72	143	14.50	5	21:02:00	144	181.94	5	21:52:18	437	873	194.86	31	9:00:34	874	2.30	31	9:50:52
301	601	15.22	21	20:59:07	602	182.66	21	21:49:25	165	329	195.58	12	8:57:41	330	3.02	12	9:47:59
29	57	15.94	2	20:56:15	58	183.38	2	21:46:33	394	787	196.30	28	8:54:49	788	3.74	28	9:45:07
258	515	16.66	18	20:53:23	516	184.10	18	21:43:40	122	243	197.02	9	8:51:56	244	4.46	9	9:42:14
487	973	17.38	34	20:50:30	974	184.82	34	21:40:48	351	701	197.74	25	8:49:04	702	5.18	25	9:39:22
215	429	18.09	15	20:47:38	430	185.53	15	21:37:56	79	157	198.46	6	8:46:11	158	5.89	6	9:36:29
444	887	18.81	31	20:44:45	888	186.25	31	21:35:03	308	615	199.17	22	8:43:19	616	6.61	22	9:33:37
172	343	19.53	12	20:41:53	344	186.97	12	21:32:11	36	71	199.89	3	8:40:26	72	7.33	3	9:30:44
401	801	20.25	28	20:39:00	802	187.69	28	21:29:18	265	529	200.61	19	8:37:34	530	8.05	19	9:27:52
129	257	20.97	9	20:36:08	258	188.41	9	21:26:26	494	987	201.33	35	8:34:42	988	8.77	35	9:25:00
358	715	21.69	25	20:33:15	716	189.13	25	21:23:33	222	443	202.05	16	8:31:49	444	9.49	16	9:22:07
86	171	22.41	6	20:30:23	172	189.85	6	21:20:41	451	901	202.77	32	8:28:57	902	10.21	32	9:19:15
315	629	23.12	22	20:27:30	630	190.56	22	21:17:48	179	357	203.49	13	8:26:04	358	10.92	13	9:16:22
43	85	23.84	3	20:24:38	86	191.28	3	21:14:56	408	815	204.20	29	8:23:12	816	11.64	29	9:13:30
272	543	24.56	19	20:21:46	544	192.00	19	21:12:03	136	271	204.92	10	8:20:19	272	12.36	10	9:10:37
501	1001	25.28	35	20:18:53	1002	192.72	35	21:09:11	365	729	205.64	26	8:17:27	730	13.08	26	9:07:45
229	457	26.00	16	20:16:01	458	193.44	16	21:06:19	93	185	206.36	7	8:14:34	186	13.80	7	9:04:52
458	915	26.72	32	20:13:08	916	194.16	32	21:03:26	322	643	207.08	23	8:11:42	644	14.52	23	9:02:00
186	371	27.44	13	20:10:16	372	194.88	13	21:00:34	50	99	207.80	4	8:08:49	100	15.24	4	8:59:07
415	829	28.15	29	20:07:23	830	195.59	29	20:57:41	279	557	208.52	20	8:05:57	558	15.95	20	8:56:15
143	285	28.87	10	20:04:31	286	196.31	10	20:54:49	7	13	209.23	1	8:03:05	14	16.67	1	8:53:23
372	743	29.59	26	20:01:38	744	197.03	26	20:51:56	236	471	209.95	17	8:00:12	472	17.39	17	8:50:30
100	199	30.31	7	19:58:46	200	197.75	7	20:49:04	465	929	210.67	33	7:57:20	930	18.11	33	8:47:38
329	657	31.03	23	19:55:53	658	198.47	23	20:46:11	193	385	211.39	14	7:54:27	386	18.83	14	8:44:45
57	113	31.75	4	19:53:01	114	199.19	4	20:43:19	422	843	212.11	30	7:51:35	844	19.55	30	8:41:53
286	571	32.47	20	19:50:09	572	199.91	20	20:40:26	150	299	212.83	11	7:48:42	300	20.27	11	8:39:00
14	27	33.18	1	19:47:16	28	200.62	1	20:37:34	379	757	213.55	27	7:45:50	758	20.98	27	8:36:08
243	485	33.90	17	19:44:24	486	201.34	17	20:34:42	107	213	214.26	8	7:42:57	214	21.70	8	8:33:15
472	943	34.62	33	19:41:31	944	202.06	33	20:31:49	336	671	214.98	24	7:40:05	672	22.42	24	8:30:23
200	399	35.34	14	19:38:39	400	202.78	14	20:28:57	64	127	215.70	5	7:37:12	128	23.14	5	8:27:30
429	857	36.06	30	19:35:46	858	203.50	30	20:26:04	293	585	216.42	21	7:34:20	586	23.86	21	8:24:38
157	313	36.78	11	19:32:54	314	204.22	11	20:23:12	21	41	217.14	2	7:31:28	42	24.58	2	8:21:46
386	771	37.50	27	19:30:01	772	204.94	27	20:20:19	250	499	217.86	18	7:28:35	500	25.30	18	8:18:53
114	227	38.21	8	19:27:09	228	205.65	8	20:17:27	479	957	218.58	34	7:25:43	958	26.01	34	8:16:01
343	685	38.93	24	19:24:16	686	206.37	24	20:14:34	207	413	219.29	15	7:22:50	414	26.73	15	8:13:08
71	141	39.65	5	19:21:24	142	207.09	5	20:11:42	436	871	220.01	31	7:19:58	872	27.45	31	8:10:16
300	599	40.37	21	19:18:32	600	207.81	21	20:08:49	164	327	220.73	12	7:17:05	328	28.17	12	8:07:23
28	55	41.09	2	19:15:39	56	208.53	2	20:05:57	393	785	221.45	28	7:14:13	786	28.89	28	8:04:31
257	513	41.81	18	19:12:47	514	209.25	18	20:03:05	121	241	222.17	9	7:11:20	242	29.61	9	8:01:38



RO	Ascending Passes				Descending Passes				RO	Ascending Passes				Descending Passes			
	P	Long.	D	UTC	P	Long.	D	UTC		P	Long.	D	UTC	P	Long.	D	UTC
486	971	42.53	34	19:09:54	972	209.97	34	20:00:12	350	699	222.89	25	7:08:28	700	30.33	25	7:58:46
214	427	43.24	15	19:07:02	428	210.68	15	19:57:20	78	155	223.61	6	7:05:35	156	31.04	6	7:55:53
443	885	43.96	31	19:04:09	886	211.40	31	19:54:27	307	613	224.32	22	7:02:43	614	31.76	22	7:53:01
171	341	44.68	12	19:01:17	342	212.12	12	19:51:35	35	69	225.04	3	6:59:51	70	32.48	3	7:50:09
400	799	45.40	28	18:58:24	800	212.84	28	19:48:42	264	527	225.76	19	6:56:58	528	33.20	19	7:47:16
128	255	46.12	9	18:55:32	256	213.56	9	19:45:50	493	985	226.48	35	6:54:06	986	33.92	35	7:44:24
357	713	46.84	25	18:52:39	714	214.28	25	19:42:57	221	441	227.20	16	6:51:13	442	34.64	16	7:41:31
85	169	47.56	6	18:49:47	170	215.00	6	19:40:05	450	899	227.92	32	6:48:21	900	35.36	32	7:38:39
314	627	48.27	22	18:46:55	628	215.71	22	19:37:12	178	355	228.64	13	6:45:28	356	36.07	13	7:35:46
42	83	48.99	3	18:44:02	84	216.43	3	19:34:20	407	813	229.35	29	6:42:36	814	36.79	29	7:32:54
271	541	49.71	19	18:41:10	542	217.15	19	19:31:28	135	269	230.07	10	6:39:43	270	37.51	10	7:30:01
500	999	50.43	35	18:38:17	1000	217.87	35	19:28:35	364	727	230.79	26	6:36:51	728	38.23	26	7:27:09
228	455	51.15	16	18:35:25	456	218.59	16	19:25:43	92	183	231.51	7	6:33:58	184	38.95	7	7:24:16
457	913	51.87	32	18:32:32	914	219.31	32	19:22:50	321	641	232.23	23	6:31:06	642	39.67	23	7:21:24
185	369	52.59	13	18:29:40	370	220.02	13	19:19:58	49	97	232.95	4	6:28:14	98	40.39	4	7:18:32
414	827	53.30	29	18:26:47	828	220.74	29	19:17:05	278	555	233.67	20	6:25:21	556	41.10	20	7:15:39
142	283	54.02	10	18:23:55	284	221.46	10	19:14:13	6	11	234.38	1	6:22:29	12	41.82	1	7:12:47
371	741	54.74	26	18:21:02	742	222.18	26	19:11:20	235	469	235.10	17	6:19:36	470	42.54	17	7:09:54
99	197	55.46	7	18:18:10	198	222.90	7	19:08:28	464	927	235.82	33	6:16:44	928	43.26	33	7:07:02
328	655	56.18	23	18:15:18	656	223.62	23	19:05:35	192	383	236.54	14	6:13:51	384	43.98	14	7:04:09
56	111	56.90	4	18:12:25	112	224.34	4	19:02:43	421	841	237.26	30	6:10:59	842	44.70	30	7:01:17
285	569	57.62	20	18:09:33	570	225.06	20	18:59:51	149	297	237.98	11	6:08:06	298	45.42	11	6:58:24
13	25	58.33	1	18:06:40	26	225.77	1	18:56:58	378	755	238.70	27	6:05:14	756	46.13	27	6:55:32
242	483	59.05	17	18:03:48	484	226.49	17	18:54:06	106	211	239.41	8	6:02:21	212	46.85	8	6:52:39
471	941	59.77	33	18:00:55	942	227.21	33	18:51:13	335	669	240.13	24	5:59:29	670	47.57	24	6:49:47
199	397	60.49	14	17:58:03	398	227.93	14	18:48:21	63	125	240.85	5	5:56:37	126	48.29	5	6:46:55
428	855	61.21	30	17:55:10	856	228.65	30	18:45:28	292	583	241.57	21	5:53:44	584	49.01	21	6:44:02
156	311	61.93	11	17:52:18	312	229.37	11	18:42:36	20	39	242.29	2	5:50:52	40	49.73	2	6:41:10
385	769	62.65	27	17:49:25	770	230.09	27	18:39:43	249	497	243.01	18	5:47:59	498	50.45	18	6:38:17
113	225	63.36	8	17:46:33	226	230.80	8	18:36:51	478	955	243.73	34	5:45:07	956	51.16	34	6:35:25
342	683	64.08	24	17:43:40	684	231.52	24	18:33:58	206	411	244.44	15	5:42:14	412	51.88	15	6:32:32
70	139	64.80	5	17:40:48	140	232.24	5	18:31:06	435	869	245.16	31	5:39:22	870	52.60	31	6:29:40
299	597	65.52	21	17:37:56	598	232.96	21	18:28:14	163	325	245.88	12	5:36:29	326	53.32	12	6:26:47
27	53	66.24	2	17:35:03	54	233.68	2	18:25:21	392	783	246.60	28	5:33:37	784	54.04	28	6:23:55
256	511	66.96	18	17:32:11	512	234.40	18	18:22:29	120	239	247.32	9	5:30:44	240	54.76	9	6:21:02
485	969	67.68	34	17:29:18	970	235.12	34	18:19:36	349	697	248.04	25	5:27:52	698	55.48	25	6:18:10
213	425	68.39	15	17:26:26	426	235.83	15	18:16:44	77	153	248.76	6	5:25:00	154	56.19	6	6:15:18
442	883	69.11	31	17:23:33	884	236.55	31	18:13:51	306	611	249.47	22	5:22:07	612	56.91	22	6:12:25
170	339	69.83	12	17:20:41	340	237.27	12	18:10:59	34	67	250.19	3	5:19:15	68	57.63	3	6:09:33
399	797	70.55	28	17:17:48	798	237.99	28	18:08:06	263	525	250.91	19	5:16:22	526	58.35	19	6:06:40
127	253	71.27	9	17:14:56	254	238.71	9	18:05:14	492	983	251.63	35	5:13:30	984	59.07	35	6:03:48
356	711	71.99	25	17:12:03	712	239.43	25	18:02:21	220	439	252.35	16	5:10:37	440	59.79	16	6:00:55
84	167	72.71	6	17:09:11	168	240.15	6	17:59:29	449	897	253.07	32	5:07:45	898	60.51	32	5:58:03
313	625	73.42	22	17:06:19	626	240.86	22	17:56:37	177	353	253.79	13	5:04:52	354	61.22	13	5:55:10
41	81	74.14	3	17:03:26	82	241.58	3	17:53:44	406	811	254.50	29	5:02:00	812	61.94	29	5:52:18
270	539	74.86	19	17:00:34	540	242.30	19	17:50:52	134	267	255.22	10	4:59:07	268	62.66	10	5:49:25
499	997	75.58	35	16:57:41	998	243.02	35	17:47:59	363	725	255.94	26	4:56:15	726	63.38	26	5:46:33
227	453	76.30	16	16:54:49	454	243.74	16	17:45:07	91	181	256.66	7	4:53:23	182	64.10	7	5:43:40
456	911	77.02	32	16:51:56	912	244.46	32	17:42:14	320	639	257.38	23	4:50:30	640	64.82	23	5:40:48
184	367	77.74	13	16:49:04	368	245.17	13	17:39:22	48	95	258.10	4	4:47:38	96	65.54	4	5:37:56
413	825	78.45	29	16:46:11	826	245.89	29	17:36:29	277	553	258.82	20	4:44:45	554	66.25	20	5:35:03
141	281	79.17	10	16:43:19	282	246.61	10	17:33:37	5	9	259.53	1	4:41:53	10	66.97	1	5:32:11
370	739	79.89	26	16:40:26	740	247.33	26	17:30:44	234	467	260.25	17	4:39:00	468	67.69	17	5:29:18
98	195	80.61	7	16:37:34	196	248.05	7	17:27:52	463	925	260.97	33	4:36:08	926	68.41	33	5:26:26
327	653	81.33	23	16:34:42	654	248.77	23	17:25:00	191	381	261.69	14	4:33:15	382	69.13	14	5:23:33
55	109	82.05	4	16:31:49	110	249.49	4	17:22:07	420	839	262.41	30	4:30:23	840	69.85	30	5:20:41
284	567	82.77	20	16:28:57	568	250.21	20	17:19:15	148	295	263.13	11	4:27:30	296	70.57	11	5:17:48
12	23	83.48	1	16:26:04	24	250.92	1	17:16:22	377	753	263.85	27	4:24:38	754	71.28	27	5:14:56
241	481	84.20	17	16:23:12	482	251.64	17	17:13:30	105	209	264.56	8	4:21:46	210	72.00	8	5:12:03
470	939	84.92	33	16:20:19	940	252.36	33	17:10:37	334	667	265.28	24	4:18:53	668	72.72	24	5:09:11
198	395	85.64	14	16:17:27	396	253.08	14	17:07:45	62	123	266.00	5	4:16:01	124	73.44	5	5:06:19
427	853	86.36	30	16:14:34	854	253.80	30	17:04:52	291	581	266.72	21	4:13:08	582	74.16	21	5:03:26
155	309	87.08	11	16:11:42	310	254.52	11	17:02:00	19	37	267.44	2	4:10:16	38	74.88	2	5:00:34
384	767	87.80	27	16:08:49	768	255.24	27	16:59:07	248	495	268.16	18	4:07:23	496	75.60	18	4:57:41



RO	Ascending Passes				Descending Passes				RO	Ascending Passes				Descending Passes			
	P	Long.	D	UTC	P	Long.	D	UTC		P	Long.	D	UTC	P	Long.	D	UTC
112	223	88.51	8	16:05:57	224	255.95	8	16:56:15	477	953	268.87	34	4:04:31	954	76.31	34	4:54:49
341	681	89.23	24	16:03:05	682	256.67	24	16:53:23	205	409	269.59	15	4:01:38	410	77.03	15	4:51:56
69	137	89.95	5	16:00:12	138	257.39	5	16:50:30	434	867	270.31	31	3:58:46	868	77.75	31	4:49:04
298	595	90.67	21	15:57:20	596	258.11	21	16:47:38	162	323	271.03	12	3:55:53	324	78.47	12	4:46:11
26	51	91.39	2	15:54:27	52	258.83	2	16:44:45	391	781	271.75	28	3:53:01	782	79.19	28	4:43:19
255	509	92.11	18	15:51:35	510	259.55	18	16:41:53	119	237	272.47	9	3:50:09	238	79.91	9	4:40:26
484	967	92.83	34	15:48:42	968	260.27	34	16:39:00	348	695	273.19	25	3:47:16	696	80.63	25	4:37:34
212	423	93.54	15	15:45:50	424	260.98	15	16:36:08	76	151	273.90	6	3:44:24	152	81.34	6	4:34:42
441	881	94.26	31	15:42:57	882	261.70	31	16:33:15	305	609	274.62	22	3:41:31	610	82.06	22	4:31:49
169	337	94.98	12	15:40:05	338	262.42	12	16:30:23	33	65	275.34	3	3:38:39	66	82.78	3	4:28:57
398	795	95.70	28	15:37:12	796	263.14	28	16:27:30	262	523	276.06	19	3:35:46	524	83.50	19	4:26:04
126	251	96.42	9	15:34:20	252	263.86	9	16:24:38	491	981	276.78	35	3:32:54	982	84.22	35	4:23:12
355	709	97.14	25	15:31:28	710	264.58	25	16:21:46	219	437	277.50	16	3:30:01	438	84.94	16	4:20:19
83	165	97.86	6	15:28:35	166	265.30	6	16:18:53	448	895	278.22	32	3:27:09	896	85.66	32	4:17:27
312	623	98.57	22	15:25:43	624	266.01	22	16:16:01	176	351	278.93	13	3:24:16	352	86.37	13	4:14:34
40	79	99.29	3	15:22:50	80	266.73	3	16:13:08	405	809	279.65	29	3:21:24	810	87.09	29	4:11:42
269	537	100.01	19	15:19:58	538	267.45	19	16:10:16	133	265	280.37	10	3:18:32	266	87.81	10	4:08:49
498	995	100.73	35	15:17:05	996	268.17	35	16:07:23	362	723	281.09	26	3:15:39	724	88.53	26	4:05:57
226	451	101.45	16	15:14:13	452	268.89	16	16:04:31	90	179	281.81	7	3:12:47	180	89.25	7	4:03:05
455	909	102.17	32	15:11:20	910	269.61	32	16:01:38	319	637	282.53	23	3:09:54	638	89.97	23	4:00:12
183	365	102.89	13	15:08:28	366	270.33	13	15:58:46	47	93	283.25	4	3:07:02	94	90.69	4	3:57:20
412	823	103.60	29	15:05:35	824	271.04	29	15:55:53	276	551	283.96	20	3:04:09	552	91.40	20	3:54:27
140	279	104.32	10	15:02:43	280	271.76	10	15:53:01	4	7	284.68	1	3:01:17	8	92.12	1	3:51:35
369	737	105.04	26	14:59:51	738	272.48	26	15:50:09	233	465	285.40	17	2:58:24	466	92.84	17	3:48:42
97	193	105.76	7	14:56:58	194	273.20	7	15:47:16	462	923	286.12	33	2:55:32	924	93.56	33	3:45:50
326	651	106.48	23	14:54:06	652	273.92	23	15:44:24	190	379	286.84	14	2:52:39	380	94.28	14	3:42:57
54	107	107.20	4	14:51:13	108	274.64	4	15:41:31	419	837	287.56	30	2:49:47	838	95.00	30	3:40:05
283	565	107.92	20	14:48:21	566	275.36	20	15:38:39	147	293	288.28	11	2:46:55	294	95.72	11	3:37:12
11	21	108.63	1	14:45:28	22	276.07	1	15:35:46	376	751	288.99	27	2:44:02	752	96.43	27	3:34:20
240	479	109.35	17	14:42:36	480	276.79	17	15:32:54	104	207	289.71	8	2:41:10	208	97.15	8	3:31:28
469	937	110.07	33	14:39:43	938	277.51	33	15:30:01	333	665	290.43	24	2:38:17	666	97.87	24	3:28:35
197	393	110.79	14	14:36:51	394	278.23	14	15:27:09	61	121	291.15	5	2:35:25	122	98.59	5	3:25:43
426	851	111.51	30	14:33:58	852	278.95	30	15:24:16	290	579	291.87	21	2:32:32	580	99.31	21	3:22:50
154	307	112.23	11	14:31:06	308	279.67	11	15:21:24	18	35	292.59	2	2:29:40	36	100.03	2	3:19:58
383	765	112.95	27	14:28:14	766	280.39	27	15:18:32	247	493	293.31	18	2:26:47	494	100.75	18	3:17:05
111	221	113.66	8	14:25:21	222	281.10	8	15:15:39	476	951	294.02	34	2:23:55	952	101.46	34	3:14:13
340	679	114.38	24	14:22:29	680	281.82	24	15:12:47	204	407	294.74	15	2:21:02	408	102.18	15	3:11:20
68	135	115.10	5	14:19:36	136	282.54	5	15:09:54	433	865	295.46	31	2:18:10	866	102.90	31	3:08:28
297	593	115.82	21	14:16:44	594	283.26	21	15:07:02	161	321	296.18	12	2:15:18	322	103.62	12	3:05:35
25	49	116.54	2	14:13:51	50	283.98	2	15:04:09	390	779	296.90	28	2:12:25	780	104.34	28	3:02:43
254	507	117.26	18	14:10:59	508	284.70	18	15:01:17	118	235	297.62	9	2:09:33	236	105.06	9	2:59:51
483	965	117.98	34	14:08:06	966	285.42	34	14:58:24	347	693	298.34	25	2:06:40	694	105.77	25	2:56:58
211	421	118.70	15	14:05:14	422	286.13	15	14:55:32	75	149	299.05	6	2:03:48	150	106.49	6	2:54:06
440	879	119.41	31	14:02:21	880	286.85	31	14:52:39	304	607	299.77	22	2:00:55	608	107.21	22	2:51:13
168	335	120.13	12	13:59:29	336	287.57	12	14:49:47	32	63	300.49	3	1:58:03	64	107.93	3	2:48:21
397	793	120.85	28	13:56:37	794	288.29	28	14:46:55	261	521	301.21	19	1:55:10	522	108.65	19	2:45:28
125	249	121.57	9	13:53:44	250	289.01	9	14:44:02	490	979	301.93	35	1:52:18	980	109.37	35	2:42:36
354	707	122.29	25	13:50:52	708	289.73	25	14:41:10	218	435	302.65	16	1:49:25	436	110.09	16	2:39:43
82	163	123.01	6	13:47:59	164	290.45	6	14:38:17	447	893	303.37	32	1:46:33	894	110.80	32	2:36:51
311	621	123.72	22	13:45:07	622	291.16	22	14:35:25	175	349	304.08	13	1:43:40	350	111.52	13	2:33:58
39	77	124.44	3	13:42:14	78	291.88	3	14:32:32	404	807	304.80	29	1:40:48	808	112.24	29	2:31:06
268	535	125.16	19	13:39:22	536	292.60	19	14:29:40	132	263	305.52	10	1:37:56	264	112.96	10	2:28:14
497	993	125.88	35	13:36:29	994	293.32	35	14:26:47	361	721	306.24	26	1:35:03	722	113.68	26	2:25:21
225	449	126.60	16	13:33:37	450	294.04	16	14:23:55	89	177	306.96	7	1:32:11	178	114.40	7	2:22:29
454	907	127.32	32	13:30:44	908	294.76	32	14:21:02	318	635	307.68	23	1:29:18	636	115.12	23	2:19:36
182	363	128.04	13	13:27:52	364	295.48	13	14:18:10	46	91	308.40	4	1:26:26	92	115.83	4	2:16:44
411	821	128.75	29	13:25:00	822	296.19	29	14:15:18	275	549	309.11	20	1:23:33	550	116.55	20	2:13:51
139	277	129.47	10	13:22:07	278	296.91	10	14:12:25	3	5	309.83	1	1:20:41	6	117.27	1	2:10:59
368	735	130.19	26	13:19:15	736	297.63	26	14:09:33	232	463	310.55	17	1:17:48	464	117.99	17	2:08:06
96	191	130.91	7	13:16:22	192	298.35	7	14:06:40	461	921	311.27	33	1:14:56	922	118.71	33	2:05:14
325	649	131.63	23	13:13:30	650	299.07	23	14:03:48	189	377	311.99	14	1:12:03	378	119.43	14	2:02:21
53	105	132.35	4	13:10:37	106	299.79	4	14:00:55	418	835	312.71	30	1:09:11	836	120.15	30	1:59:29
282	563	133.07	20	13:07:45	564	300.51	20	13:58:03	146	291	313.43	11	1:06:19	292	120.86	11	1:56:37
10	19	133.78	1	13:04:52	20	301.22	1	13:55:10	375	749	314.14	27	1:03:26	750	121.58	27	1:53:44



RO	Ascending Passes				Descending Passes				RO	Ascending Passes				Descending Passes			
	P	Long.	D	UTC	P	Long.	D	UTC		P	Long.	D	UTC	P	Long.	D	UTC
239	477	134.50	17	13:02:00	478	301.94	17	13:52:18	103	205	314.86	8	1:00:34	206	122.30	8	1:50:52
468	935	135.22	33	12:59:07	936	302.66	33	13:49:25	332	663	315.58	24	0:57:41	664	123.02	24	1:47:59
196	391	135.94	14	12:56:15	392	303.38	14	13:46:33	60	119	316.30	5	0:54:49	120	123.74	5	1:45:07
425	849	136.66	30	12:53:23	850	304.10	30	13:43:40	289	577	317.02	21	0:51:56	578	124.46	21	1:42:14
153	305	137.38	11	12:50:30	306	304.82	11	13:40:48	17	33	317.74	2	0:49:04	34	125.17	2	1:39:22
382	763	138.10	27	12:47:38	764	305.54	27	13:37:56	246	491	318.46	18	0:46:11	492	125.89	18	1:36:29
110	219	138.81	8	12:44:45	220	306.25	8	13:35:03	475	949	319.17	34	0:43:19	950	126.61	34	1:33:37
339	677	139.53	24	12:41:53	678	306.97	24	13:32:11	203	405	319.89	15	0:40:26	406	127.33	15	1:30:44
67	133	140.25	5	12:39:00	134	307.69	5	13:29:18	432	863	320.61	31	0:37:34	864	128.05	31	1:27:52
296	591	140.97	21	12:36:08	592	308.41	21	13:26:26	160	319	321.33	12	0:34:42	320	128.77	12	1:25:00
24	47	141.69	2	12:33:15	48	309.13	2	13:23:33	389	777	322.05	28	0:31:49	778	129.49	28	1:22:07
253	505	142.41	18	12:30:23	506	309.85	18	13:20:41	117	233	322.77	9	0:28:57	234	130.21	9	1:19:15
482	963	143.13	34	12:27:30	964	310.57	34	13:17:48	346	691	323.49	25	0:26:04	692	130.92	25	1:16:22
210	419	143.84	15	12:24:38	420	311.28	15	13:14:56	74	147	324.20	6	0:23:12	148	131.64	6	1:13:30
439	877	144.56	31	12:21:46	878	312.00	31	13:12:03	303	605	324.92	22	0:20:19	606	132.36	22	1:10:37
167	333	145.28	12	12:18:53	334	312.72	12	13:09:11	31	61	325.64	3	0:17:27	62	133.08	3	1:07:45
396	791	146.00	28	12:16:01	792	313.44	28	13:06:19	260	519	326.36	19	0:14:34	520	133.80	19	1:04:52
124	247	146.72	9	12:13:08	248	314.16	9	13:03:26	489	977	327.08	35	0:11:42	978	134.52	35	1:02:00
353	705	147.44	25	12:10:16	706	314.88	25	13:00:34	217	433	327.80	16	0:08:49	434	135.23	16	0:59:07
81	161	148.16	6	12:07:23	162	315.60	6	12:57:41	446	891	328.52	32	0:05:57	892	135.95	32	0:56:15
310	619	148.87	22	12:04:31	620	316.31	22	12:54:49	174	347	329.23	13	0:03:05	348	136.67	13	0:53:23
38	75	149.59	3	12:01:38	76	317.03	3	12:51:56	403	805	329.95	29	0:00:12	806	137.39	29	0:50:30
267	533	150.31	19	11:58:46	534	317.75	19	12:49:04	131	261	330.67	9	23:57:20	262	138.11	10	0:47:38
496	991	151.03	35	11:55:53	992	318.47	35	12:46:11	360	719	331.39	25	23:54:27	720	138.83	26	0:44:45
224	447	151.75	16	11:53:01	448	319.19	16	12:43:19	88	175	332.11	6	23:51:35	176	139.55	7	0:41:53
453	905	152.47	32	11:50:09	906	319.91	32	12:40:26	317	633	332.83	22	23:48:42	634	140.27	23	0:39:00
181	361	153.19	13	11:47:16	362	320.62	13	12:37:34	45	89	333.55	3	23:45:50	90	140.98	4	0:36:08
410	819	153.90	29	11:44:24	820	321.34	29	12:34:42	274	547	334.26	19	23:42:57	548	141.70	20	0:33:15
138	275	154.62	10	11:41:31	276	322.06	10	12:31:49	2	3	334.98	0	23:40:05	4	142.42	1	0:30:23
367	733	155.34	26	11:38:39	734	322.78	26	12:28:57	231	461	335.70	16	23:37:12	462	143.14	17	0:27:30
95	189	156.06	7	11:35:46	190	323.50	7	12:26:04	460	919	336.42	32	23:34:20	920	143.86	33	0:24:38
324	647	156.78	23	11:32:54	648	324.22	23	12:23:12	188	375	337.14	13	23:31:28	376	144.58	14	0:21:46
52	103	157.50	4	11:30:01	104	324.94	4	12:20:19	417	833	337.86	29	23:28:35	834	145.30	30	0:18:53
281	561	158.22	20	11:27:09	562	325.66	20	12:17:27	145	289	338.58	10	23:25:43	290	146.01	11	0:16:01
9	17	158.93	1	11:24:16	18	326.37	1	12:14:34	374	747	339.29	26	23:22:50	748	146.73	27	0:13:08
238	475	159.65	17	11:21:24	476	327.09	17	12:11:42	102	203	340.01	7	23:19:58	204	147.45	8	0:10:16
467	933	160.37	33	11:18:32	934	327.81	33	12:08:49	331	661	340.73	23	23:17:05	662	148.17	24	0:07:23
195	389	161.09	14	11:15:39	390	328.53	14	12:05:57	59	117	341.45	4	23:14:13	118	148.89	5	0:04:31
424	847	161.81	30	11:12:47	848	329.25	30	12:03:05	288	575	342.17	20	23:11:20	576	149.61	21	0:01:38
152	303	162.53	11	11:09:54	304	329.97	11	12:00:12	16	31	342.89	1	23:08:28	32	150.32	1	23:58:46
381	761	163.25	27	11:07:02	762	330.69	27	11:57:20	245	489	343.61	17	23:05:35	490	151.04	17	23:55:53
109	217	163.96	8	11:04:09	218	331.40	8	11:54:27	474	947	344.32	33	23:02:43	948	151.76	33	23:53:01
338	675	164.68	24	11:01:17	676	332.12	24	11:51:35	202	403	345.04	14	22:59:51	404	152.48	14	23:50:09
66	131	165.40	5	10:58:24	132	332.84	5	11:48:42	431	861	345.76	30	22:56:58	862	153.20	30	23:47:16
295	589	166.12	21	10:55:32	590	333.56	21	11:45:50	159	317	346.48	11	22:54:06	318	153.92	11	23:44:24
23	45	166.84	2	10:52:39	46	334.28	2	11:42:57	388	775	347.20	27	22:51:13	776	154.64	27	23:41:31
252	503	167.56	18	10:49:47	504	335.00	18	11:40:05	116	231	347.92	8	22:48:21	232	155.36	8	23:38:39
481	961	168.28	34	10:46:55	962	335.72	34	11:37:12	345	689	348.63	24	22:45:28	690	156.07	24	23:35:46
209	417	168.99	15	10:44:02	418	336.43	15	11:34:20	73	145	349.35	5	22:42:36	146	156.79	5	23:32:54
438	875	169.71	31	10:41:10	876	337.15	31	11:31:28	302	603	350.07	21	22:39:43	604	157.51	21	23:30:01
166	331	170.43	12	10:38:17	332	337.87	12	11:28:35	30	59	350.79	2	22:36:51	60	158.23	2	23:27:09
395	789	171.15	28	10:35:25	790	338.59	28	11:25:43	259	517	351.51	18	22:33:58	518	158.95	18	23:24:16
123	245	171.87	9	10:32:32	246	339.31	9	11:22:50	488	975	352.23	34	22:31:06	976	159.67	34	23:21:24
352	703	172.59	25	10:29:40	704	340.03	25	11:19:58	216	431	352.95	15	22:28:14	432	160.38	15	23:18:32
80	159	173.31	6	10:26:47	160	340.74	6	11:17:05	445	889	353.66	31	22:25:21	890	161.10	31	23:15:39
309	617	174.02	22	10:23:55	618	341.46	22	11:14:13	173	345	354.38	12	22:22:29	346	161.82	12	23:12:47
37	73	174.74	3	10:21:02	74	342.18	3	11:11:20	402	803	355.10	28	22:19:36	804	162.54	28	23:09:54
266	531	175.46	19	10:18:10	532	342.90	19	11:08:28	130	259	355.82	9	22:16:44	260	163.26	9	23:07:02
495	989	176.18	35	10:15:18	990	343.62	35	11:05:35	359	717	356.54	25	22:13:51	718	163.98	25	23:04:09
223	445	176.90	16	10:12:25	446	344.34	16	11:02:43	87	173	357.26	6	22:10:59	174	164.70	6	23:01:17
452	903	177.62	32	10:09:33	904	345.06	32	10:59:51	316	631	357.98	22	22:08:06	632	165.42	22	22:58:24
180	359	178.34	13	10:06:40	360	345.77	13	10:56:58	44	87	358.69	3	22:05:14	88	166.13	3	22:55:32
409	817	179.05	29	10:03:48	818	346.49	29	10:54:06	273	545	359.41	19	22:02:21	546	166.85	19	22:52:39
137	273	179.77	10	10:00:55	274	347.21	10	10:51:13									

