

Subsea Communications

Dmitriy Kovsh

Senior Director of System Design and Product Management

SubCom



Modern Undersea Systems

- System Topologies, Requirements, Examples

Design Methodology

- SDM: Optimization to lower system cost/bit

“Open Cable”

- Design, Implementation and Acceptance

Enabling Technologies

- High Fiber Count products (C and C+L)
- Enhanced Branching Units (fiber switching)
- Undersea ROADMs

Subsea Communications: Pacific and Indian Oceans

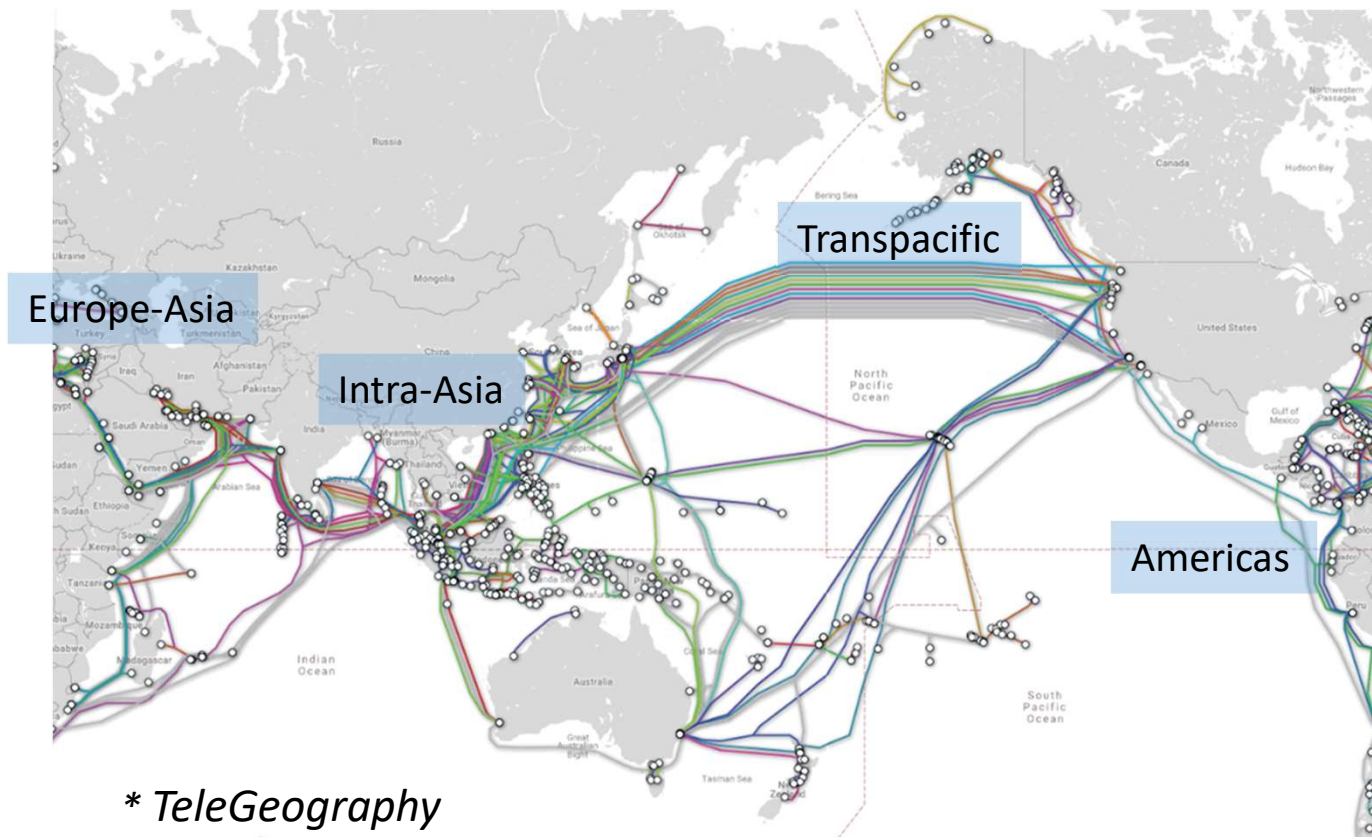

Modern Undersea Systems

- System Topologies, Requirements, Examples

Design Methodology

- SDM: Optimization to lower system cost/bit

“Open Cable”

- Design, Implementation and Acceptance

Enabling Technologies

- High Fiber Count products (C and C+L)
- Enhanced Branching Units (fiber switching)
- Undersea ROADMs

Types of Undersea Communication Systems

- ▶ **Transoceanic (5,000 – 13,000km)**
 - High Capacity Pipes
 - Connections between Continents
- ▶ **Regional/Festoon networks (< 5,000km)**
 - Connecting regional locations, with ROADM nodes
 - Nested branches, perhaps with mesh networks
 - Concatenation of systems via terrestrial bypasses
- ▶ **“Repeaterless” links (<500km)**
 - No electrical power in the undersea cable
 - Systems connecting Islands, or perhaps locations along the coast
- ▶ **Oil & Gas, Scientific networks**
 - Connecting oil platforms or other special assets



Transoceanic Systems

Connectivity

- ▶ A large multi-fiber pair pipe
- ▶ “split” into few branches near shore

Capacity

- ▶ ≥ 6 Fiber Pairs (FPs)
- ▶ ≥ 15 Tbps on each FP
- ▶ Open Cable Design (SLTE Independent)

Terminal Equipment

- ▶ Single SLTE vendor on some FPs
- ▶ Multi-owner Spectrum Sharing on other FPs

Powering

- ▶ Single End Feeding (SEF) is a must (*resilience to shunt faults near one end*)
- ▶ Powering may limit available capacity



Regional/Festoon Networks

Connectivity

- ▶ Trunk and many Branches
- ▶ Nested branches and mesh
- ▶ (existent) Terrestrial Bypasses & Extensions

Capacity

- ▶ ≥ 8 Fiber Pairs (FPs)
- ▶ ≥ 18 Tbps on each FP
- ▶ Capacity/FP drives the design

Terminal Equipment

- ▶ Spectrum Sharing on all FPs
- ▶ Multiple owners

Powering

- ▶ Need configurable powering scheme, so can do repairs w/o taking down entire network

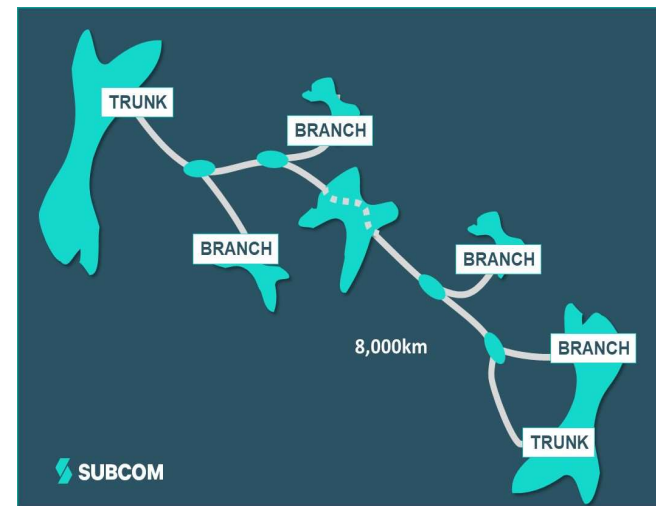

Repeaterless Links

Connectivity

- ▶ Point-to-point links
- ▶ Islands or points on coastline

Capacity

- ▶ A wide range: (from 1x100G to many Tb/s)
- ▶ May have many FPs for future expansion

Terminal Equipment

- ▶ Need experience in high power repeaterless gear (Raman pumps, Boosters, ROPA)
- ▶ Operational challenges with high-power sources

Powering

- ▶ Everything powered from the station
- ▶ No high voltage PFEs to power cables

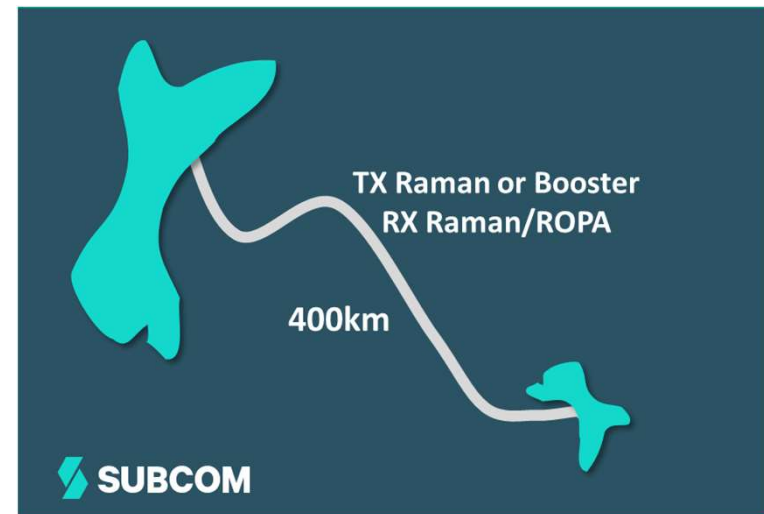

Oil & Gas Networks

Connectivity

- ▶ Trunk w/ connections to many platforms
- ▶ Design should support expansion to future platforms

Capacity

- ▶ Modest capacity for each platform (1x100G or less)

Terminal Equipment

- ▶ High Reliability
- ▶ Small Footprint

Powering

- ▶ Reconfigurable, to keep network active during repairs of some segments

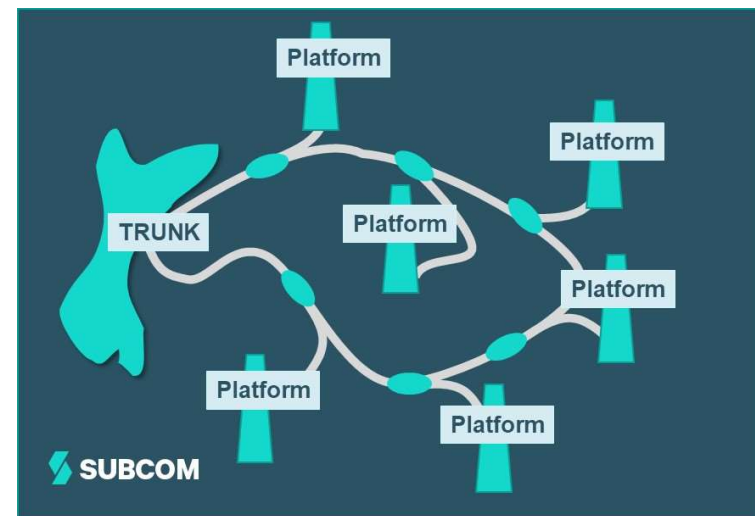

Modern Undersea Systems

- System Topologies, Requirements, Examples

Design Methodology

- SDM: Optimization to lower system cost/bit

“Open Cable”

- Design, Implementation and Acceptance

Enabling Technologies

- High Fiber Count products (C and C+L)
- Enhanced Branching Units (fiber switching)
- Undersea ROADMs

System Design – A Global Optimization Process

System design is complex, with many interacting design decisions

Electrical:

- Cable type and conductivity, repeater powering, PFE.

Optical:

- Fiber characteristics, repeater parameters, span length, number of repeaters.

Architecture:

- Type of branching units, OADM and/or ROADM implementation for network flexibility.

Route:

- Selection of route to facilitate system installation and maintenance, lower risk of repairs.

Economics:

- Performance/Capacity vs. total system cost (SDM).

Including cost/bit metric into system design is the essence of SDM designs (more later).



Cable Powering

Submarine cables are powered through the cable from shore

- **Power Conductors in the Cable**
 - Sized to support the required power level for a given system.
- **Power Switched Branching Units (PSBUs) along the cable**
 - To reconfigurably route power through the networks.
 - To maintain powering in surviving segments during repairs.
- **Power Feed Equipment (PFEs) in the Cable Landing Stations**
 - The required PFE size depends on system length and features such as
 - cable type, (number and type) of repeaters, branching units.
 - Specific customers' requirement on powering in case of faults

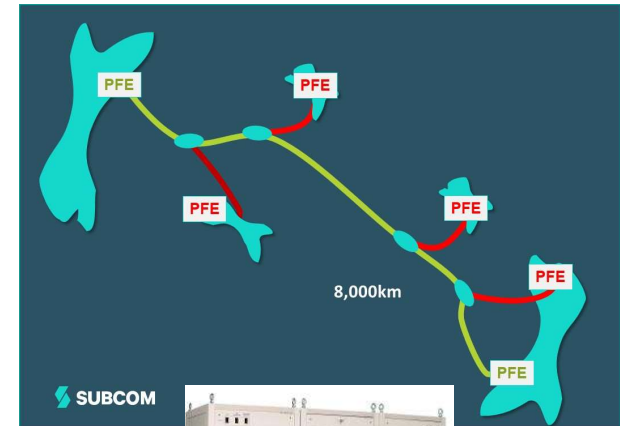

The overall powering scheme is an important aspect of system design optimization.



Changing Submarine Cable Design Goals

- ▶ New submarine systems are designed based on projected capacity needs.
 - Customer capacity requirements are increasing every year (~ 30% growth)
- ▶ But the industry is nearing the practical limits of SMF fiber capacity growth:
 - Pushing fiber pair capacity leads to very expensive and power thirsty wet-plant
- ▶ FP ownership models are also changing:
 - More of individual customers buying multiple FPs
 - Less of multiple owners sharing single Fiber Pairs

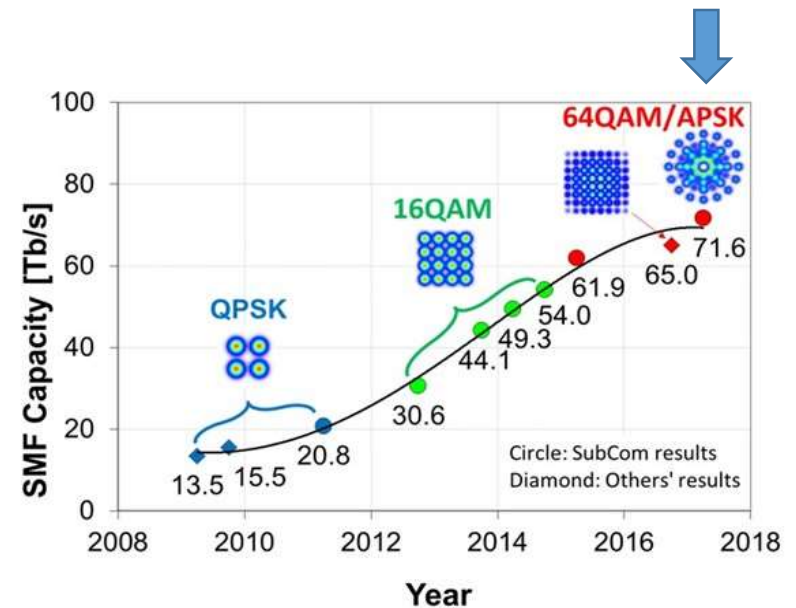

Trade-off between quoted capacity and FP price becomes crucial in selecting the right design.



SDM Fundamentals

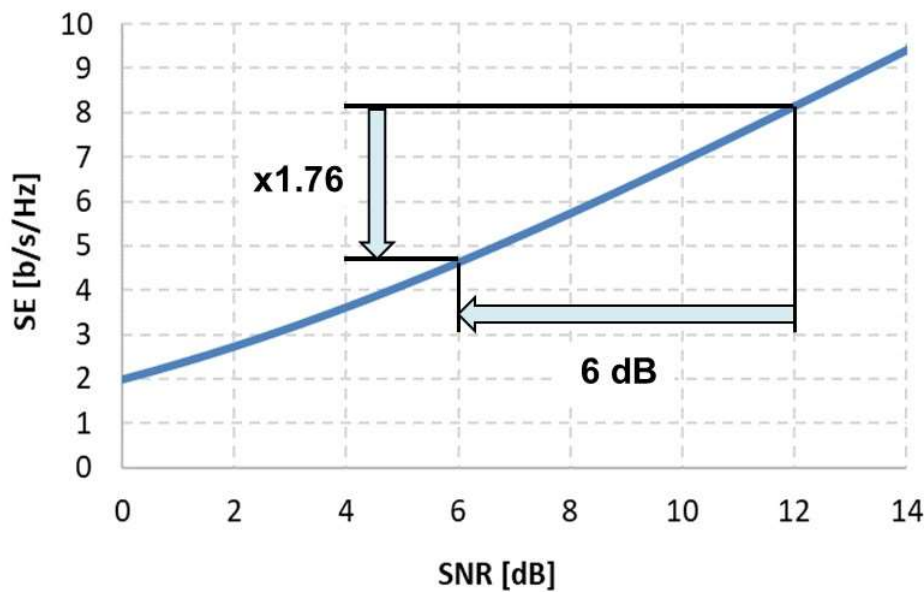

Spectral Efficiency (SE)

$$SE = \frac{\text{Capacity}}{\text{Bandwidth}} = \frac{\text{Data Rate}}{\text{Channel Spacing}}$$

Signal-to-Noise Ratio (SNR)

$$SNR \sim \frac{P_{ch}}{(G \cdot NF - 1)N_{repeaters}}$$

Shannon Limit:

$$SE = 2 \log_2(1 + SNR)$$

Increasing SNR is not power-efficient

Sharing repeater power across parallel paths is a power efficient approach to increased capacity

SDM: Way to Increase Total Cable Capacity



What is SDM? Sharing EDFA pump power among:

- 1. More Fiber Pairs – High Fiber Count (HFC) cables**
 - *Technically, the first system with >1 fiber in the cable was SDM*
- 2. More Bands (C+L)**
 - *PLCN is the first undersea C+L system being installed (by SubCom)*
- 3. Fiber modes or fiber cores**
 - *Intensive research, some examples in short reach applications, not ready for undersea applications*

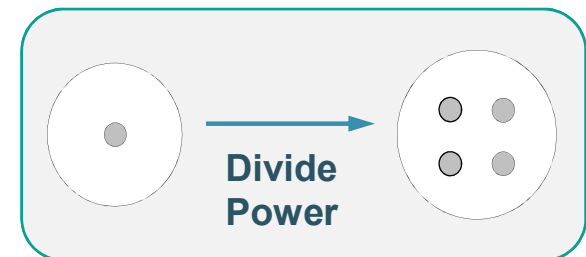
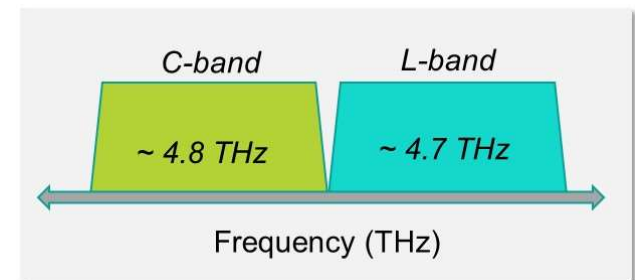

Most practical ways to increase capacity are HFC and C+L technologies

SDM: Ways to improve Power Efficiency

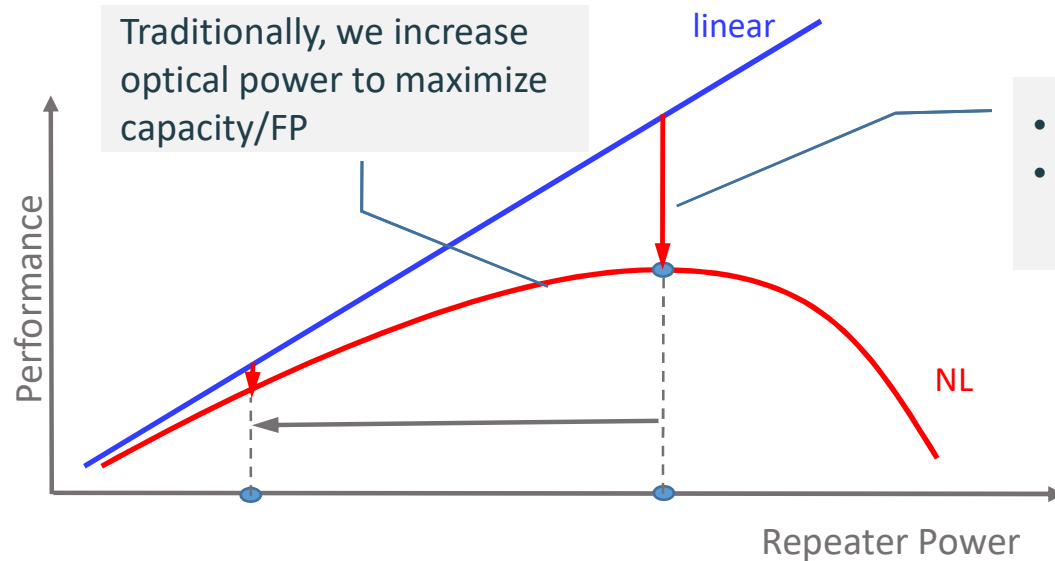

Traditionally, we increase optical power to maximize capacity/FP

- Nonlinearity penalty is ~ 1.7 dB,
- So $\sim 30\%$ of optical power is **wasted** creating nonlinear noise

In the vicinity of the peak channel performance:

- Performance grows slowly compared to Power/OSNR.
- We can operate channels at slightly low optical power levels.
- The saved electrical power can then be used to support additional FPs.

Illustration of SDM Principles

There are many optimization approaches for system design:

- Max Fiber Pair Capacity – top
- Max Power Efficiency (max capacity at fixed power) – middle
- Max Cost Efficiency – bottom

The best Cost Efficiency is always located between Max Capacity and Max Power Efficiency.

The optimal design depends on whether the system is limited by the available electrical power:

Green Trace: Systems that are not limited by the available electrical power tend to have optimal design at ~ 1 dB below the maximum capacity peak.

Orange Trace: Systems that are limited by the available electrical power tend to have more “linear” optimal designs.

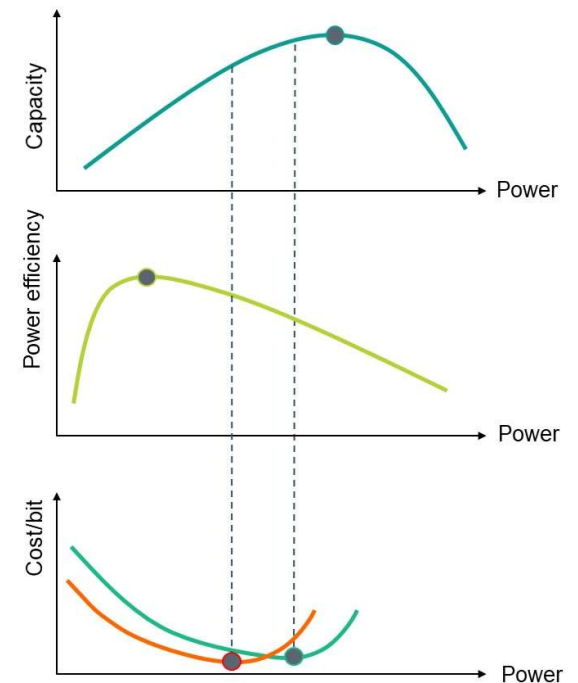

How to “Apply” SDM Principles to System Design?



Optimize system design parameters to target the lowest cost/bit solution:

- *Taking into account fiber pair capacity and electrical power efficiency*

Use modern coherent transponders that allow variable SE to make best use of all spectrum

- *Adjust line rates of individual channels to match available OSNR*

Utilize degrees of freedom offered by SDM:

- *“SDM index” (number of pumps shared by a number of fibers, e.g. 4x8)*
- *Individual Pump Power*
- *Number of FPs in the cable*

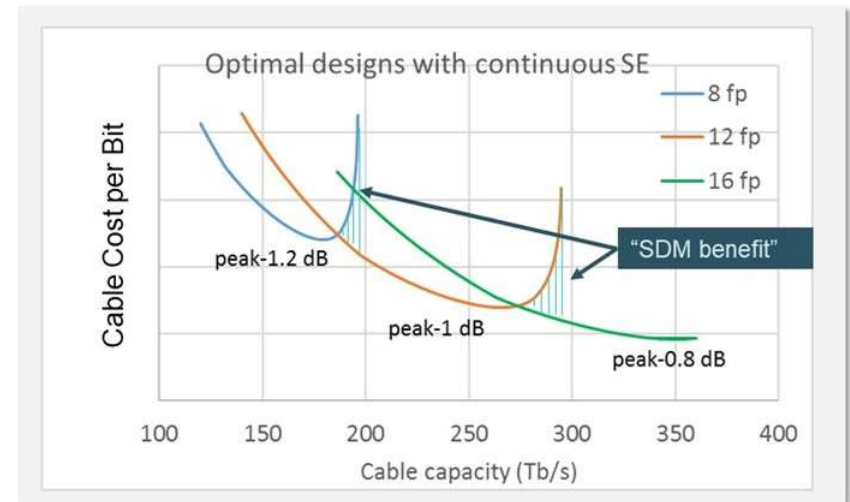

- *For each number of FPs, there is one lowest cost/bit (“optimal”) design and capacity.*
- *Optimal design is below maximum capacity/FP achievable with a given line card by ~1dB*
- *For power-limited systems (very long, many FPs) “optimal” design may be more “linear” to be more power efficient.*

Some Practical Considerations



For a system with a single owner

- Define capacity based on the minimum required for the overall cable.

For a system with multiple owners

- Define minimum required capacity/FP
- Define minimum required number of FPs

Allow cable providers offer optimal solution(s) based on their technology and cost structure.

- Best solution may have higher capacity and larger number of FPs but will be optimized for the lowest cost/bit

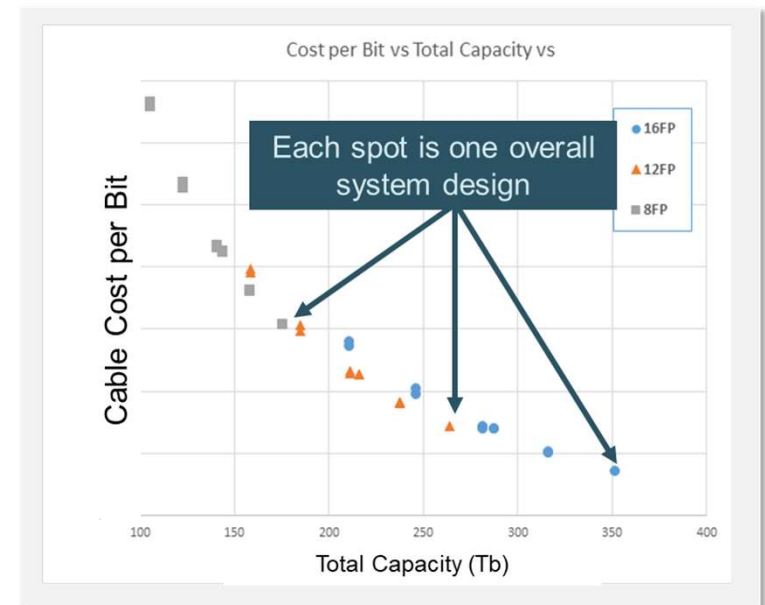

System providers can offer optimal solution(s) based on their technology and cost structures.

Design Optimization

- Same performance and Capacity/FP can be obtained using different fiber types and different repeater parameters
- Same Total Cable Capacity can be obtained with different number of FPs and different values of Capacity/FP
- Same performance/FP design solutions may have different costs.

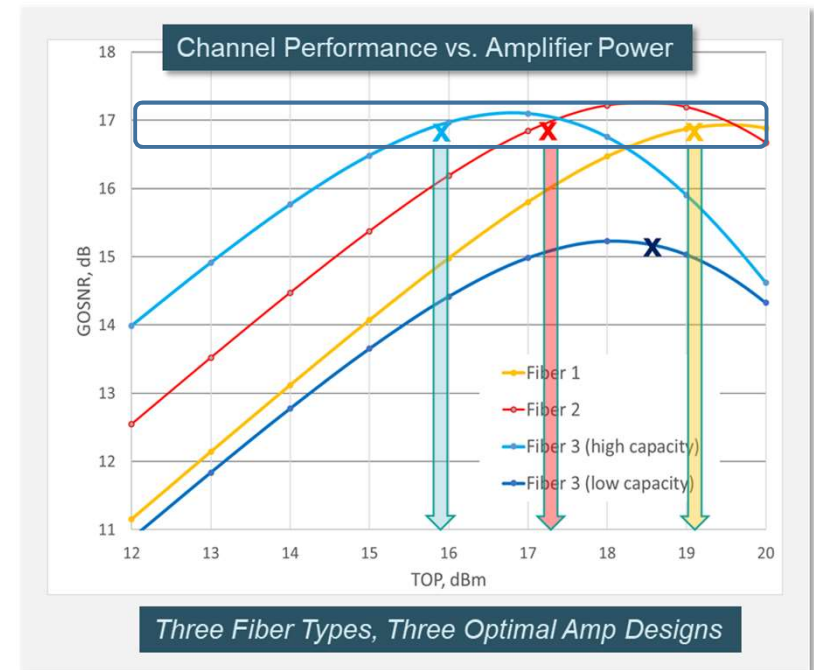

Economics will determine the best solution!

SDM: Takeaways



When requesting a system design, please keep in mind that

- The highest Fiber Pair capacity is not always the best overall solution
- Fiber Pair performance tradeoffs may be compensated by cost/bit reduction
- Same performance may be achieved with different system key parameters

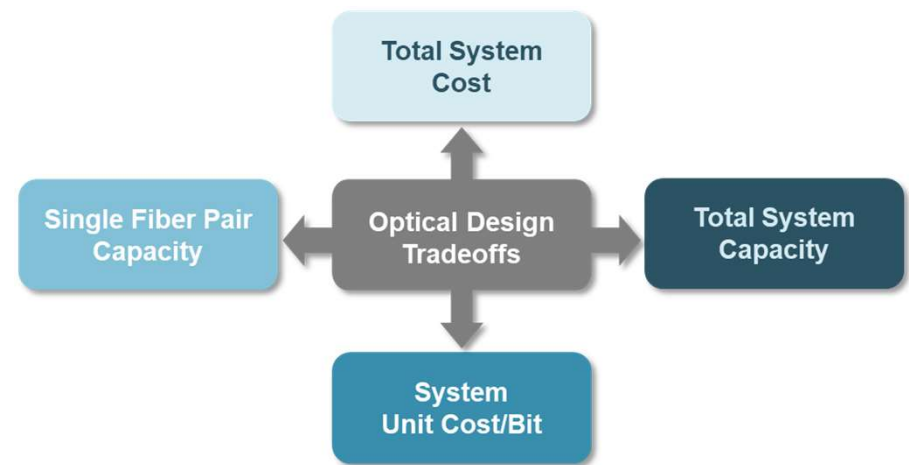

Ask cable supplier for alternative solutions to identify a design “sweet spot”

Modern Undersea Systems

- System Topologies, Requirements, Examples

Design Methodology

- SDM: Optimization to lower system cost/bit

“Open Cable”

- Design, Implementation and Acceptance

Enabling Technologies

- High Fiber Count products (C and C+L)
- Enhanced Branching Units (fiber switching)
- Undersea ROADMs

Undersea Cable System Design

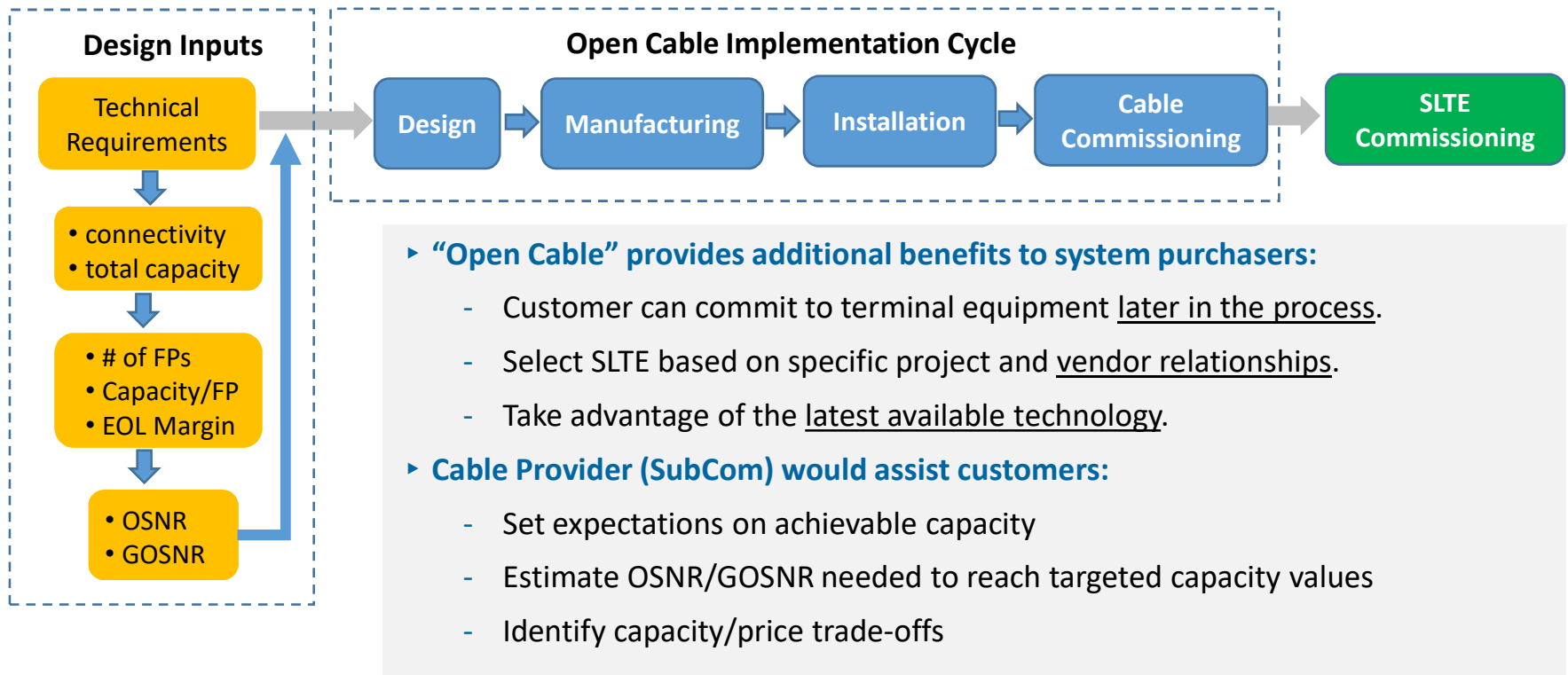

Nominal Key Parameters

DLS Specification	
DLS Length [km]	
Span Length [km]	
Number of Repeaters	
Data Passband [GHz]	
Mean PMD [ps/√km]	
Mean PDL [dB]	
Repeater Specification	
Repeater TOP [dBm]	
Repeater Noise Figure [dB]	
Repeater Gain [dB]	
Fiber Specification	
Fiber Effective Area [μm ²]	
Fiber Dispersion @ 1550nm [ps/nm/km]	
Fiber Loss (Cabled) [dB/km]	
Fiber Dispersion Slope @ 1550nm [ps/nm ² /km]	
Fiber Nonlinear Index [m ² /W]	
Repair & Aging Assumptions (BOL to EOL)	
Total SNR _{ASE} penalty for Repairs & Aging [dB]	

- These parameters are required to calculate nominal OSNR and GOSNR values in Open Cable Budget and Power Budget Tables
- Will be asked by SLTE vendors, so that they can predict performance of their equipment and generate power budgets

Path performance is described by two metrics:

- OSNR, to define the path noise characteristics
- GOSNR is a path performance characteristic that takes into account nonlinear penalty in addition to noise.

$$GOSNR = \frac{P_S}{P_{ASE} + P_{NLI}} = OSNR$$



*P. Poggiolini, "The GN Model of Non-Linear Propagation in Uncompensated Coherent Optical Systems," in *JLT*, vol. 30, no. 24, 2012

GOSNR Measurement Methodology

“Subsea Open Cables: A Practical Perspective on the Guidelines and Gotchas,” SubOptic 2019

$$SNR_{TOT} = B2B^{-1}(Q)$$

$$\frac{1}{SNR_{TOT}} = \frac{1}{GOSNR} + \frac{1}{SNR_{MODEM}}$$

$$GOSNR = GOSNR \frac{\Delta}{12.5GHz}$$

Modulation QPSK
Baud rate ~35 Gbaud
Channel Spacing 37.5 GHz
CDC penalty known
NLC OFF

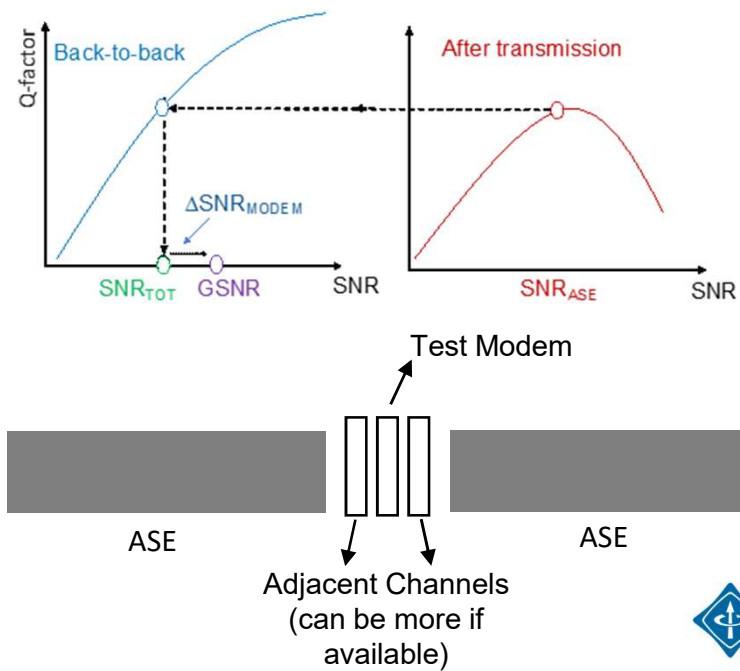

Open Cable Performance Budget Table

Illustrate how Commissioning values for Open Cable were derived (OSNR/GOSNR):

(OSNR & GOSNR units = dB/0.1nm, for 120 carriers)	OSNR	GOSNR
Design (w/o ROADM)	17.7	16.8
Impairment due to ROADM	0.7	
Signal Droop	0.2	
Impairment due to Terrestrial Extension	0.0	
Nominal	16.8	16.0
Guided Acoustic Wave Brillouin Scattering (GAWBS)		0.2
Manufacturing Margin	0.5	
Flat Launch Average Wet Plant	16.3	15.4
Equalization (or Pre-Emphasis) Margin	0.4	
Equalized Average Wet Plant	15.9	15.1
Worst Case	15.2	14.5

← Simple formula

← Simulated Nominal Performance using Key Parameters

← NF, gain equalization, local gain errors

← Residual DLS Gain Errors, Performance Equalization



Power Budget Table (PBT)

Item	Description	Q ² (dB)	E-SNR (dB)
A	BOL OSNR at 2.1 dBm Channel Power	19.64	
B	EOL OSNR at 2.1 dBm Channel Power	19.22	
1	Back-to-back Q ² at BOL OSNR	6.42	
2	Propagation Impairments	0.55	
3	Other impairments		
3.1	Non-optimal optical pre-emphasis	0.00	
3.2	Wavelength tolerance impairment	0.22	
3.3	Mean penalty due to polarization-dependent effects	0.12	
3.4	Supervisory impairment	0.00	
3.5	Manufacturing and Environmental Impairment	0.09	
3.6	Unspecified Impairment	0.00	
4	Margin for Q Time Variations (5 sigma)	0.17	
5	BOL Segment Q	5.26	
6	Repair and Aging Impairments		
6.1	Cable Repair and Aging	0.25	
6.2	TTE Aging	0.14	
7	EOL Segment Q	4.87	
8	FEC Limit	4.87	
9.1	Customer Segment EOL margin	0.00	0.00
9.2	Extra margin	0.00	0.00
10	Commissioning Limit	5.26	

- Defined in ITU-T G.977
- Provided by SLTE suppliers for upgrades
- Can be generated for a current generation modem and next generation modem
- Assumes constant SE across the band

OSNR/GOSNR Allows SLTE providers to predict capacity with any coherent modem



Some Practical Notes

System design is based on required Capacity

- Cable provider will estimate Capacity assuming specifications from a given line card provider
- Ongoing discussion in the industry how to quote Capacity of Coherent transponders (“Open Modem”): “Ultimate Capacity of Open Cable Projects”, SubOptic 2019

Performance requirements can be translated into Open Cable specs (OSNR, GOSNR)

- Customers may do it themselves or Cable provider can offer Open Cable parameters that match desired Capacity (compute OSNR/GOSNR needed to reach the required capacity)

For a given capacity let cable providers suggest the design optimized for the lowest cost/bit.

- Customers may obtain minimum OSNR and GOSNR requirements from a line card provider of choice (based on their knowledge of their equipment)

Open Cable design comparison and acceptance should be based on OSNR/GOSNR and not SLTE performance



Modern Undersea Systems

- System Topologies, Requirements, Examples

Design Methodology

- SDM: Optimization to lower system cost/bit

“Open Cable”

- Design, Implementation and Acceptance

Enabling Technologies

- High Fiber Count products (C and C+L)
- Enhanced Branching Units (fiber switching)
- Undersea ROADMs

Products for High Fiber Count Systems



HFC Cable Product for 12 / 16 / 24FP

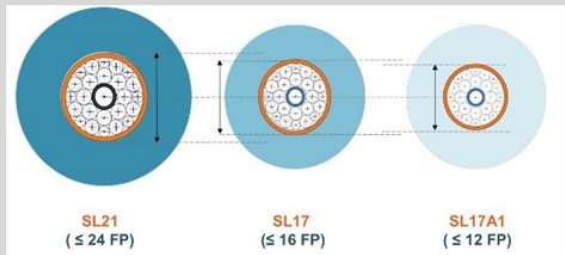

Multiple cable types for up to 24 FP systems

HFC Repeaters with Pump Sharing (16FP / 24FP / C+L)

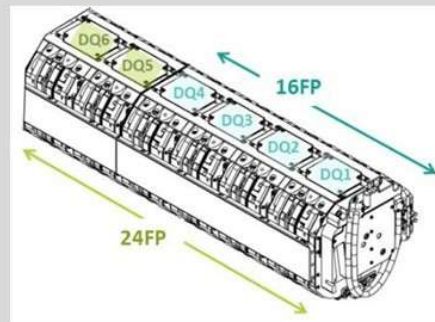

SDM designs with pump sharing

Branching Units & ROADMs



Capacity reconfigurability for HFC systems

A complete product ecosystem enabling High Capacity system designs

High Fiber Count Cable

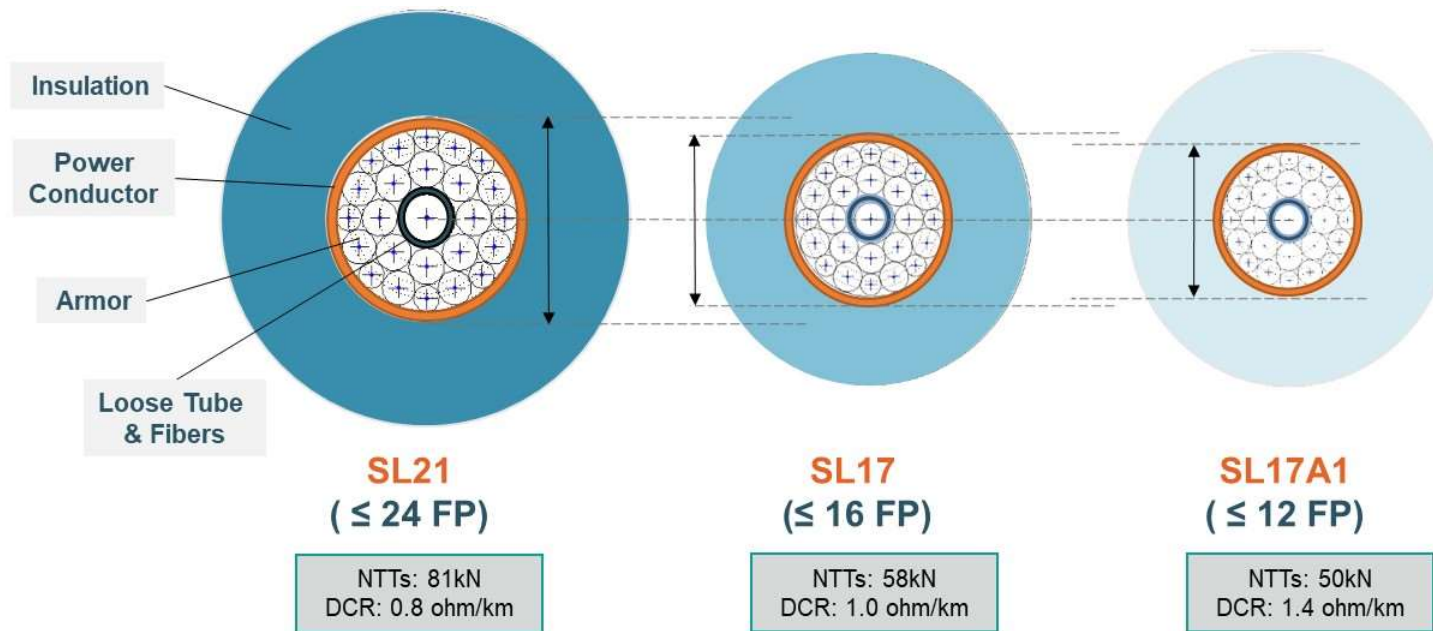

- Maintaining the same overall architecture
- Same dimensions of strength member, armor, conductor, insulator
- Same Steel, Copper, Polyethylene materials
- Same manufacturing process for cable
- New loose tube line for >12FP

A High Fiber Count cable for every application, supporting up to 24FP

HFC Amplifiers: 16FP and 24FP Repeaters

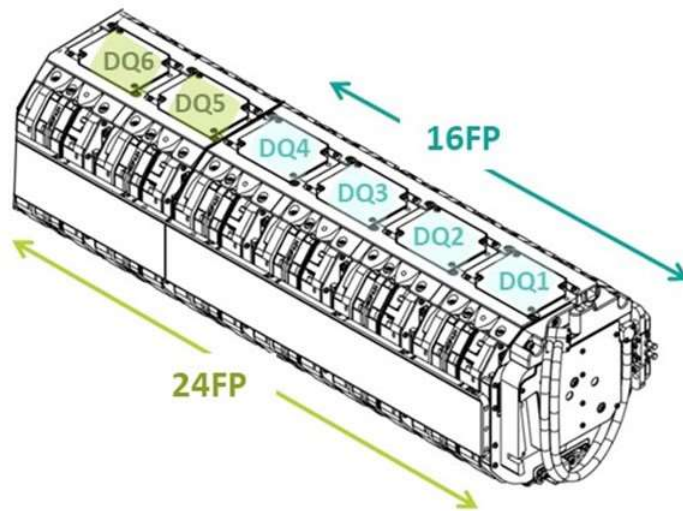

Leverages the SubCom repeater platform

- Modular design based on 4FP “Dual Quad” units
- Pump Sharing and 800mW pumps allow 4 pumps to support twice as many fiber pairs
- Reduced impact of single pump failures

Standard Body:

- Designs available for up to 16FP, or 8FP C+L

Extended Body:

- Designs available for up to 24FP, or 12FP C+L

The SubCom repeater platform has been expanded to support up to 24FP

HFC Amplifiers: Pump Sharing for Efficiency and Reliability

“Standard” 2x2 repeater (~4 FIT per FP)

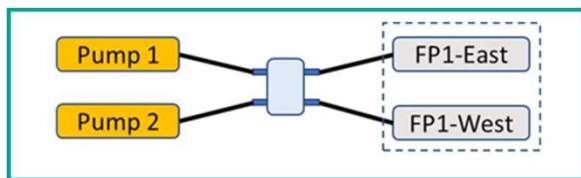

SDM repeaters are implemented with “pump sharing” architectures (pumps are shared across multiple FPs)

- Pump power can be used more efficiently (higher SDM index)
- More Fiber Pairs can be supported per Repeater
- Minimizes impact from any one Pump Failure (higher reliability)

4x4 repeater (0.001 FIT per FP)

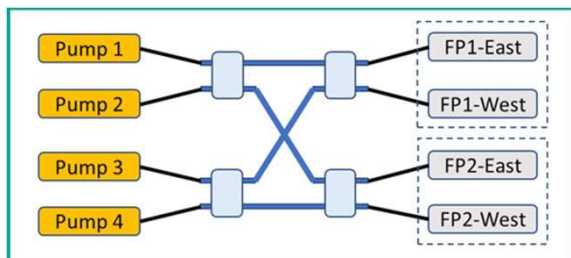

“SDM” 4x8 repeater

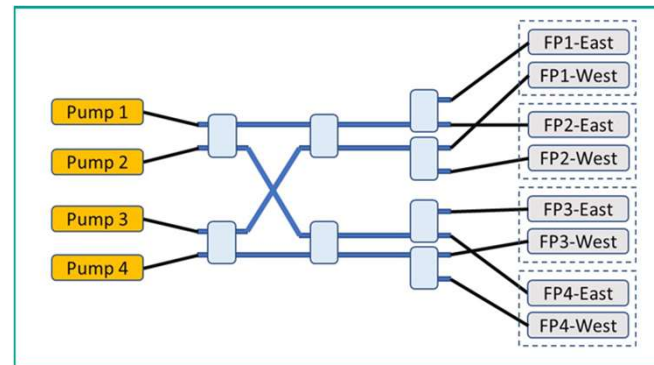

What about C+L?

- C+L offers higher capacity for systems with limited number of FPs
- Small C+L benefit over C for the same cable type (low number of FPs).
- Lower cost of C+L design solution (compared to C-band) mainly due to high cable cost.
- Relative wet-plant cost advantage of C+L compared to C-band stays the same for all distances (until design reaches Powering limitation).
- For shorter DLS lengths the advantage of C+L may be small if expressed in total system cost/bit (small ratio of wet-plant in the total system cost).

C+L repeater is another way to achieve “SDM”

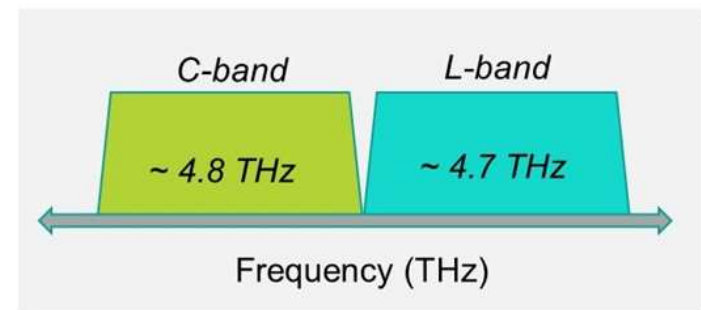

Reconfigurable Networks

Network architectures are increasingly complex

- *Many more Branch sites, with more FPs per site*

Reconfigurability has many benefits for these networks:

- *To support capacity assignment at the time of deployment,*
- *To reassign capacity to busy sites over system life.*
- *To protect and reroute traffic on surviving segments during repairs.*

Two powerful products support true network flexibility:

- *eBU Branching Units with Full Fiber Pair Switching*
- *Undersea WSS-based ROADMs.*

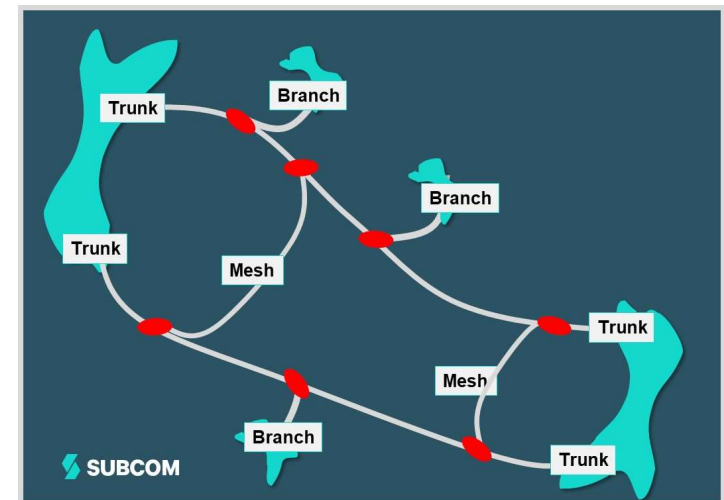

The fiber pair and ROADM complexity of undersea systems is now similar to terrestrial networks



Enhanced Branching Units (eBU) – Power and Fiber Switching

The eBU provides reconfigurable Fiber Pair and Electrical Power routing

- Optical switching to support flexible traffic routing
- Electrical switching to support flexible powering condition (facilitate repairs)

Optical switching supports optimized FP routing throughout system life

- During fault conditions or to add fiber capacity to new sites
- 1x2 Bypass switching on individual Trunk fiber pairs
- 2x2 selection between Trunk FP pairs, to establish new trunk paths.

The eBU platform can be optimized for each undersea network node

- Number of Branch FPs, and selection of 1x2 or 2x2 trunk routing functionality
- Can be deployed alone, or with WSS ROADMs for spectrum routing

SubCom eBU supports optical switching on all FPs (up to 24 trunk FPs)

- Optical switching of all FPs (up to 24 trunk FPs)
- Latched electrical power switching
- Command and response telemetry from the shore

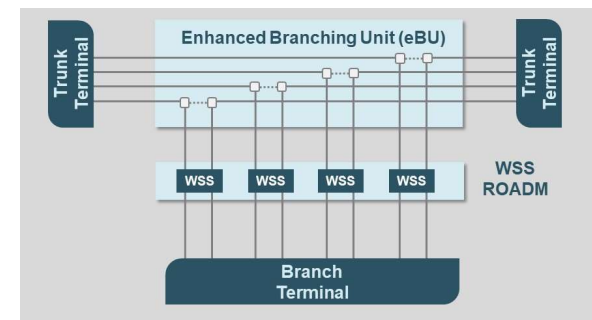

WSS ROADMs – Reconfigurable Capacity Routing

WSS ROADM provides reconfigurable optical spectrum routing

- Spectrum bands that can be adjusted in 6.25 GHz increments
- An SLTE-Vendor Neutral Wet Plant
- eBU + WSS ROADM node provides truly flexible capacity distribution

Spectrum distribution can be adjusted throughout system life

- Based on actual traffic growth

Universal spares

- Each node in the system can be different but spares can be the same

SubCom WSS ROADM

- Supports Up to 4 trunk FPs to minimize the number of required units on each Branch nodes
- Several WSS ROADM units can be concatenated to address customers' installation/maintenance requirements
- WSS ROADM offers range of power pre-emphasis to facilitate gain management and/or repairs

“Bi-directional Branch”

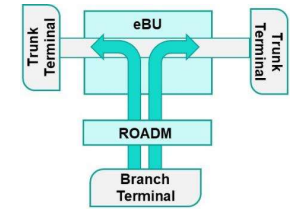

“Uni-directional Branch”

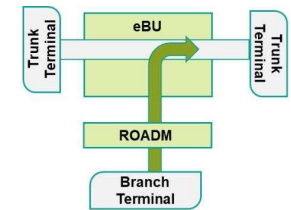

“3D Shared Branch”

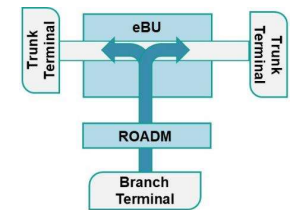

Undersea ROADM units were deployed in 2019

Ocean Control (ReST APIs) and Performance Monitoring

Network Management: Undersea systems are now providing software-defined networking capabilities, to support new management options:

- ▶ Vendor-supplied GUIs
- ▶ Integration into 3rd party Orchestrator products.
- ▶ Directly written management tools

Line Monitoring Equipment (LME): Undersea systems must be monitored from shore

LME-HLLB: In-service High Loss Loopback measurements

- ▶ detection of span loss and amplifier pump power degradation

LME-OSM: In-service Optical Spectrum Monitoring

- ▶ measurement of the TX and RX optical spectra

LME-OTDR: Out-of-service OTDR measurements

- ▶ localization of cable faults within fiber spans

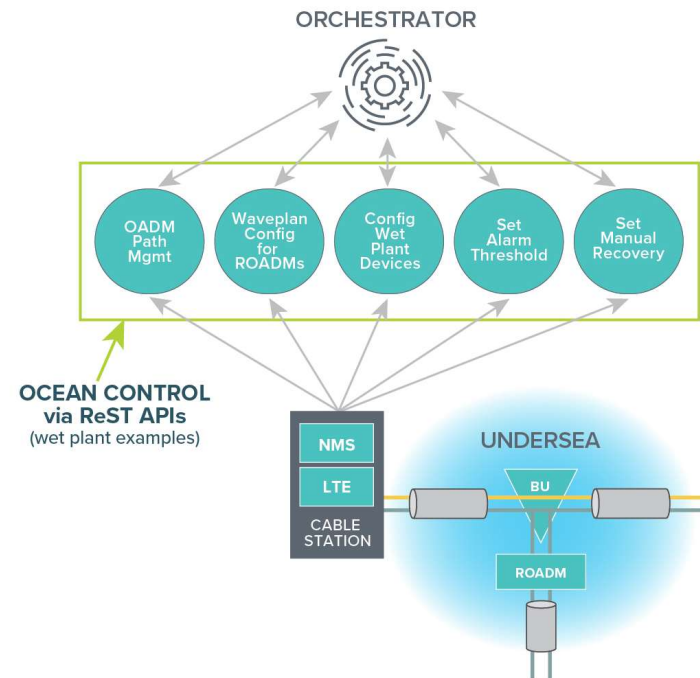

Summary – Undersea Systems are Evolving

- ▶ **“SDM” design philosophy to optimize Cable Capacity & Cost-per-Bit**
- ▶ **Higher Cable Capacity – 250-350 Tb/s per cable, moving towards 1 Petabit cables**
 - High Fiber Count cable/repeater solutions with 12 / 16 / 24 fiber pairs
 - Enhanced bandwidth options (C+L)
- ▶ **New Flexibility in Branching Node Technology**
 - Enhanced Branching Units with multiple options for full fiber switching
 - Advanced Undersea ROADM technology
- ▶ **Ocean Control Rest APIs & Next-Gen Web-based GUIs**
 - Powerful tools to enable network management integration

