

# GABELN FORKS

## SPANNSCHLOSS MIT ZWEI GABELN TURNBUCKLE WITH TWO FORKS

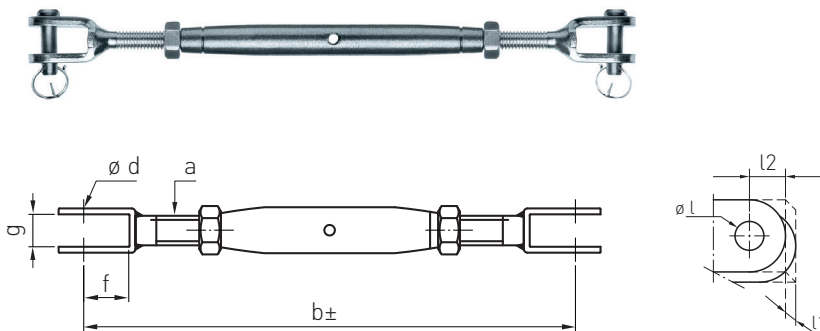

Artikelnummer Part number	a	b	f	g	ø d	Spannweg Adjustment	kN	l1	l2	ø l
8712-060	M6	180	12	7,5	5	+30   -35	11	6	10	5,5
8712-080	M8	214	13	10	6	+30   -40	16	8	10	6,5
8712-100	M10	238	15	11	8	+35   -50	26	9	12	8,5
8712-120	M12	308	25	14	12	+40   -60	31	13	20	12,5
8712-160	M16	388	31	22	14	+50   -70	69	20	23	14,5

**Werkstoff 1.4401 | kN = Bruchkraft**  
Material AISI 316 | kN = breaking load

**Alle Angaben in Millimetern**  
All dimensions in millimeters