

Expanded diffusion of distributed energy systems in Japan

~ Role of integrated DHC and CHP technologies ~

Motohiro Sei

27 May, 2014

The Japan Gas Association

Agenda

- 1. The Outlook for City Gas Business and CHP promotion in Japan**
- 2. Latest Trends in Japanese Energy Policy**
- 3. Cases of Smart Energy Networks**
- 4. Conclusion**

1. The Outlook for City Gas Business and CHP promotion in Japan



Major Tasks in the City Gas Business for the Natural Gas Shift

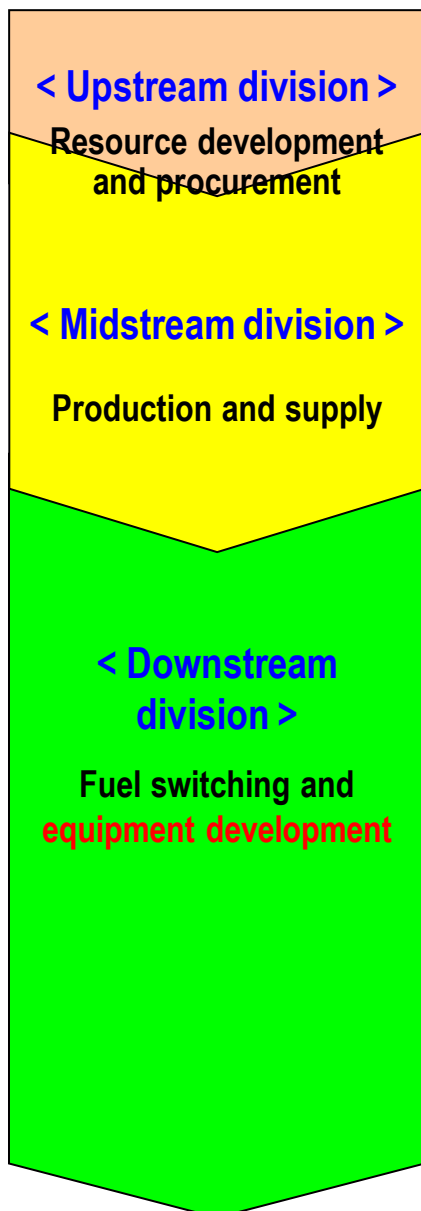

1. LNG (natural gas) cost reduction and stable procurement

- Construction of strategy for resource procurement and development through a coordinated effort by the public and private sectors

2. Construction and reinforcement of the supply infrastructure

- Strengthening of the infrastructure for stable supply of natural gas nationwide

3. Contribution to energy conservation, reduction of carbon emissions, energy security, and economic revival

- **Optimal use of thermal and electrical energy, and expanded diffusion of distributed energy systems**

○ Expanded diffusion of CHP (including fuel cells)

○ Power peak shaving through gas-fueled air conditioning

○ Saving of energy through fuel switching for industrial heat demand

○ Expanded diffusion of trucks and buses fueled with natural gas in the transport sector

○ Construction of smart energy networks

Construction and Reinforcement of the Supply Infrastructure

City gas utilities have been working to construct infrastructural networks for supply in order to promote the natural gas shift and improve security. They are going to continue with this construction based on the principle of infrastructure improvement led by the private sector, but with proper support, in the context of national policy, for infrastructure with socioeconomic worth.

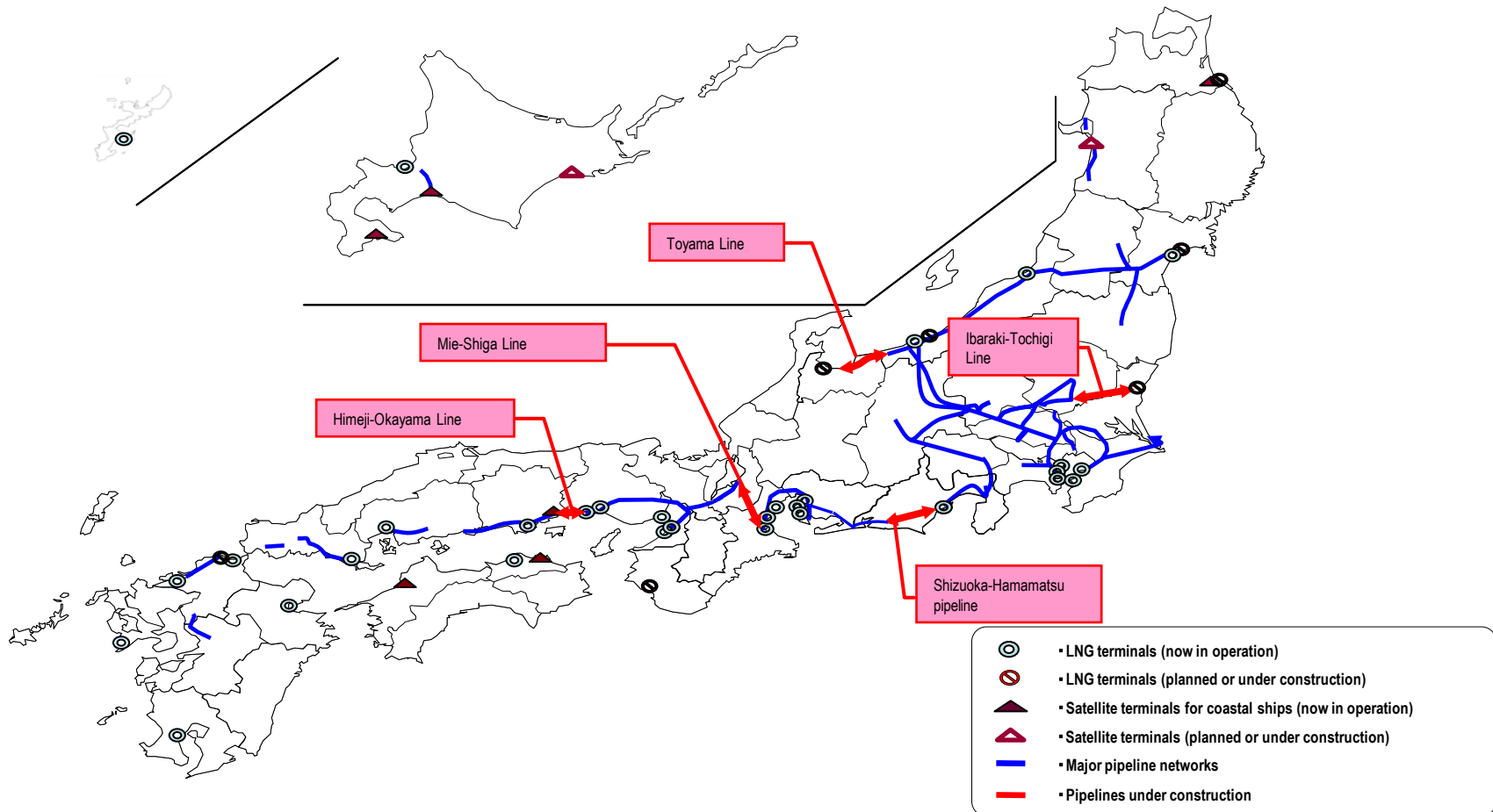

Future task: Expanded diffusion of natural gas to 2030

(announced by the JGA on October, 2011)

Vision for action by the city gas industry, together with the government, to accelerate the natural gas shift

1) CHP

4.6 million kW

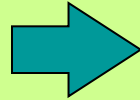

30 million kW

2) Gas-fueled air conditioning

13 million RT

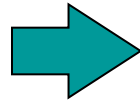

26 million RT

3) Share of the industrial thermal energy demand occupied by natural gas

10.7%

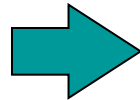

25.0%

4) Residential fuel cells

20,000 units

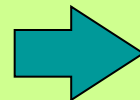

5 million units
(including LPG models)

5) Natural gas vehicles (NGV)

40,000 units

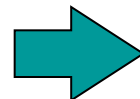

500,000 units

< Anticipated effects
(as compared to the present) >

【Amount of reduction in CO2 emissions】
About 62 million tons-CO2/year

【Power supply-demand stability】

– CHP (and fuel cells)

25 - 30 million kW

(about 15% of the annual domestic demand in terms of electrical energy)

– Power peak shaving through gas-fueled air conditioning

13 million kW

【Expansion of domestic demand (as of 2030)】

– Amount of capital investment in gas systems at left

1.2 - 1.5 trillion yen/year

Roadmap for CHP promotion

-In March 2014, a report was issued on [the results of a study about the diffusion of CHP toward 2030 from various perspectives](#). This study took up the potential for CHP input, the advisable targets of technology development, models for CHP input, utilization of waste heat, and assessment of worth in the BCP context. The Roadmap estimates for level of CHP input are indicated as follows in this report.

-Targets were also indicated for reduction of initial cost (CAPEX) and running cost (OPEX) as well as improvement in equipment efficiency.

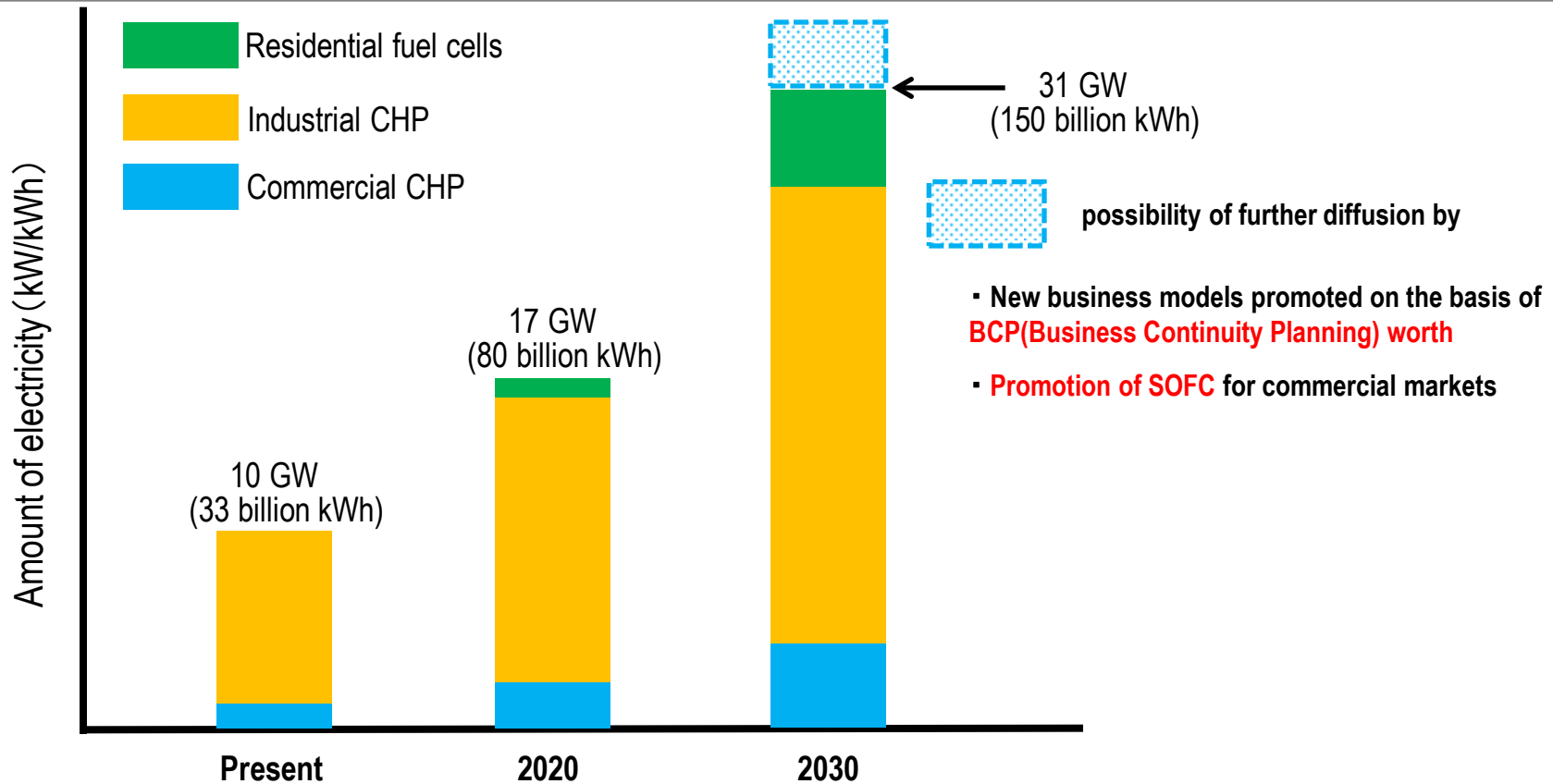

Roadmap for CHP promotion

(Source : Advanced Cogeneration and Energy Utilization Center Japan)

Latest portfolio of CHP

- High-efficient CHP achieving a higher power generation efficiency than central power plants are available.
- CHP will play an important role in all sectors with low-carbon and high energy security.

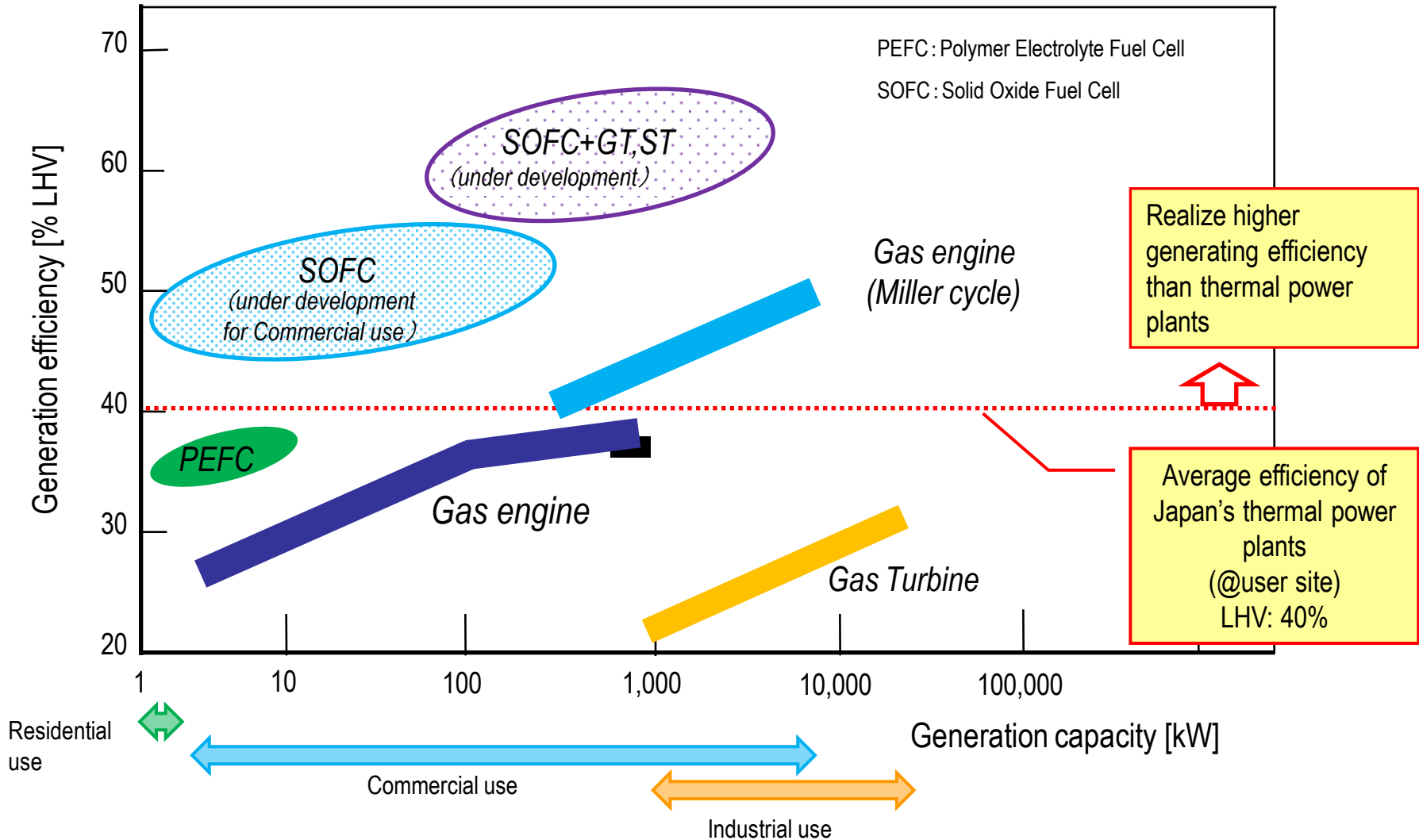

2. Latest Trends in Japanese Energy Policy



Diet Building

Ongoing Energy Policy Trends



- ✓ In the wake of the Great East Japan Earthquake(2011/3/11)
- ✓ Many thermal power plants, as well as nuclear power plant units, were damaged by tsunami
- ✓ At present, no nuclear power stations are in operation
- ✓ National initiatives for response to this situation are currently being implemented.

1. Key Points of Energy Security, Economic Efficiency, etc

➡ Revision of the Basic Energy Policy (2014.4)

2. Growing interest in more resilient energy infrastructure

➡ Formulation of the Basic Plan for Building National Resilience.(2014.5)

3. Greater importance of power conservation and shaving of power peaks

➡ Amended version of the Energy Conservation Act(2013.5)

Revision of the Basic Energy Policy (2014.4)

- Outline of text concerning stand-alone distributed power sources and CHP in the Revision of Basic Energy Policy determined by the Cabinet in April
 - Promotion of use of thermal energy from CHP and renewable energy
 - Need for promotion of the spread of distributed power sources on the local level together with improvement of the natural gas infrastructure
 - Need for expansion of CHP input through promotion of utilization in units of districts (including peripheral areas) alongside use in units of structures, factories, housing, etc.
 - Study to assist actualization by steps such as facilitation of transactions for electricity generated by CHP including fuel cells
- ⇒ There is no indication of specific targets for the power source mix in the composition of power supply. This area has been left for future discussion.

Basic Plan for Building National Resilience (draft) (2014.5)

- Outline of text concerning stand-alone distributed power sources and CHP in the Basic Plan for Building National Resilience (draft) slated for Cabinet determination in May 2014
 - Promotion of input of stand-alone, distributed energy in districts (CHP, fuel cells, renewable energy, hydrogen energy, etc.) and aim for construction of “smart city”

Amended version of the Energy Conservation Act(2013.5)

- Outline of text concerning distributed power sources and CHP in the amended version of the Energy Conservation Act
 - Leveling of the power demand was added to the objective of the Act, which also incorporated the establishment of a system for positive rating of efforts made by energy consumers to reduce their use of power from utility grids during peak demand hours.

System of Enhanced Governmental Support for CHP

- Establishment of the “Cogeneration Promotion Office” in the METI (Agency for Natural Resources and Energy) (Aug. 2012)
- Assignment of personnel to CHP in each regional bureau of the METI (Aug. 2012)

- The JGA instituted the following conference with city gas utilities to discuss expanded diffusion of CHP with the METI

- CHP Promotion Meeting

Members: METI, JGA, major city gas utilities

- Regional CHP Conference

Members: regional METI bureaus, local governments, JGA, and city gas utilities in areas under bureau jurisdiction

3. Cases of Smart Energy Networks

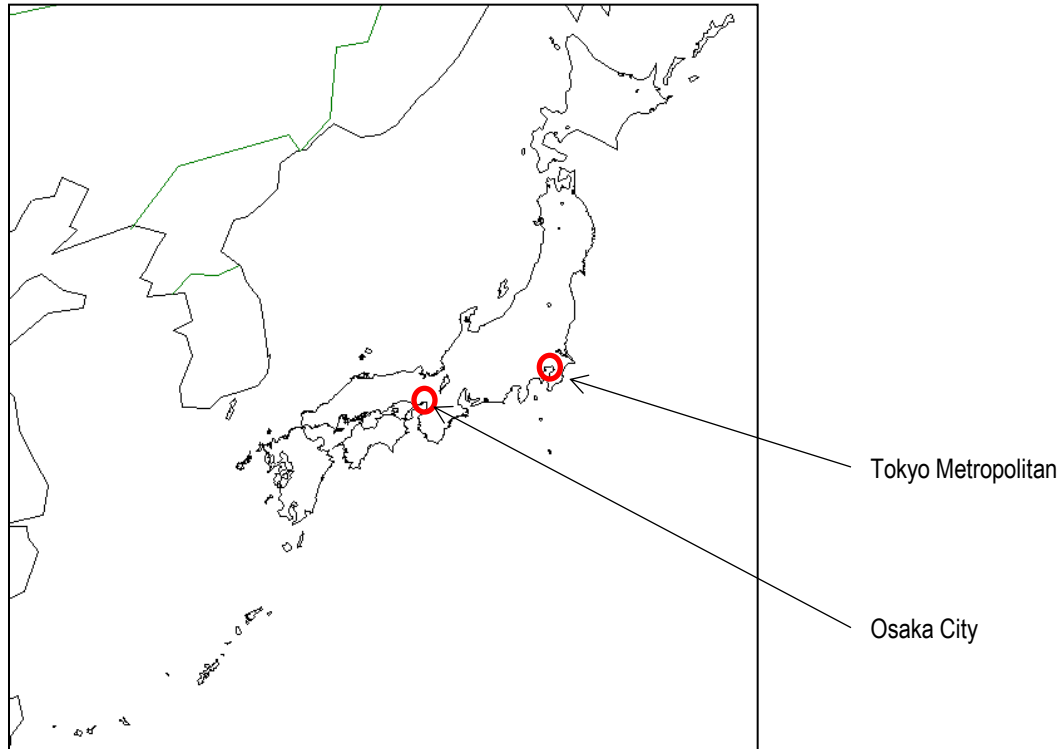

Case-1: Smart Energy Network in the Iwasaki Area (Osaka City)

Case-2: Tamachi Smart Energy Network (Tokyo Metropolitan)

Osaka City



OSAKA STATION CITY(Open 2011.5)
(Source : OBAYASI Co. HP)



KYOCERA DOME OSAKA
Smart energy network in the IWASAKI area



外観<昼景>

ABENO HARUKASU(Open 2014.3)
Highest building in Japan(300 m)
(Source : Takenaka Co. HP)

Case1: Smart Energy Network in the Iwasaki Area

- The area is redeveloping as a shopping mall and a commercial zone (Open 2013).
- In this area, a smart energy network has been incorporated into the energy system.

Heat grid

- CHP ●Solar heat collector ●Geothermal energy
- Waste heat from incineration plants

Power grid

- CHP ●PV ●Storage battery
- Demand response

Energy security

- CHP for power supply at the time of blackout
- GHP EXCEL+
- Certified gas pipelines for emergency

Total floor space (DHC supply) : 410,000m²
(DOME/160,000m², Commercial/80,000m²,etc)

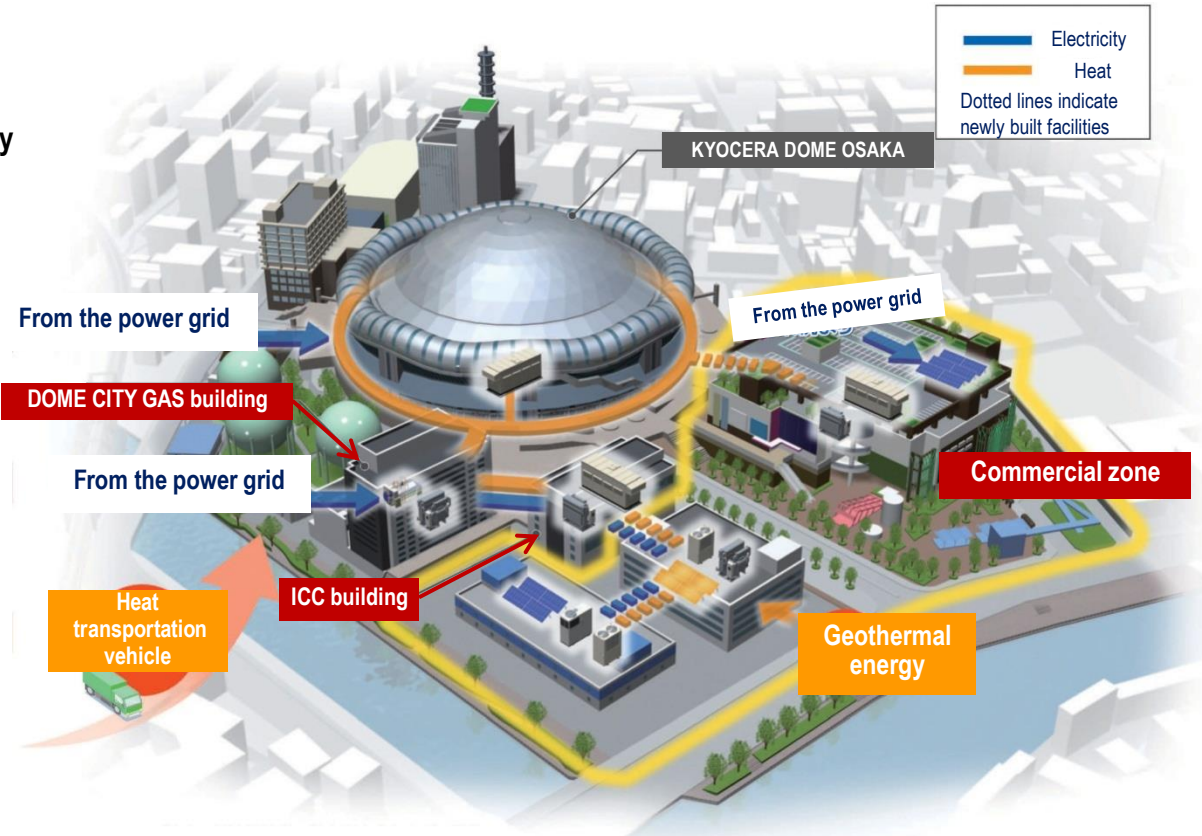

- GHP EXCEL+: a GHP type air conditioner. Air conditioning and power generation with gas are available at the time of power outage.
- Certified gas pipe lines for emergency use: gas pipelines certified by the Japan Engine Generator Association. Continuously supplying power at the time of disaster or other emergencies, free from damages.

(Source : Osaka Gas Co.)

Specially designed power supply business in the Iwasaki Area

-In this specially designed power supply business, 30-minute power balancing control is necessary for use of electric power supplied by wheeling.

-Demand response is implemented for customer CHP and batteries in accordance with supply/demand balance in the area.

Specially designed power supply business in the South-Iwasaki area (launched in July 2013)

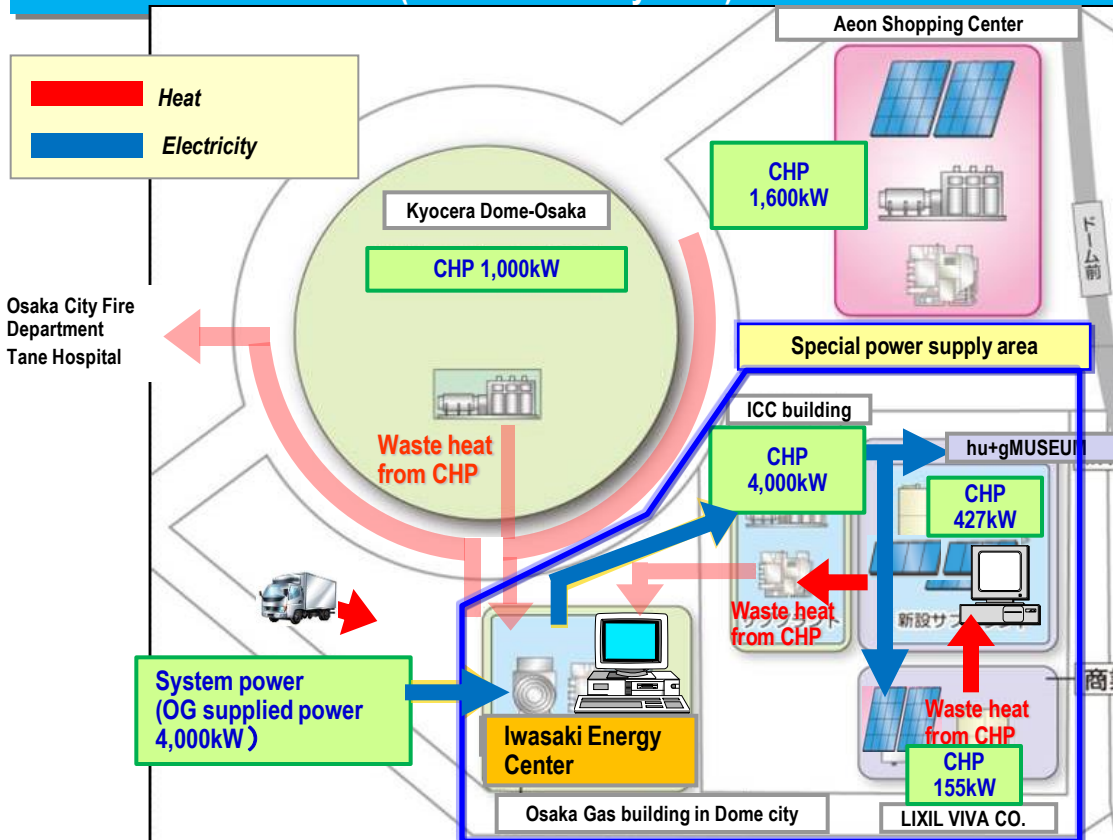

DR by system interconnection

Iwasaki Energy Center: supply/demand control system

- Real-time monitoring of demand, wheeling capacity and generation capacity within the whole South-Iwasaki area.
- Sending of a control order to the hu+gMUSEUM BEMS and CHP to achieve 30-minutes power balancing control.

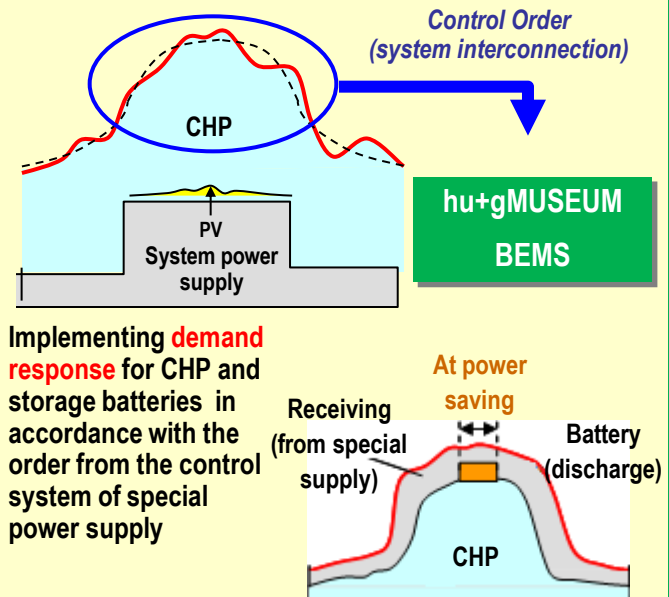

- Implementing demand response for CHP and storage batteries in accordance with the order from the control system of special power supply

(Source : Osaka Gas Co.)

Tokyo Metropolitan

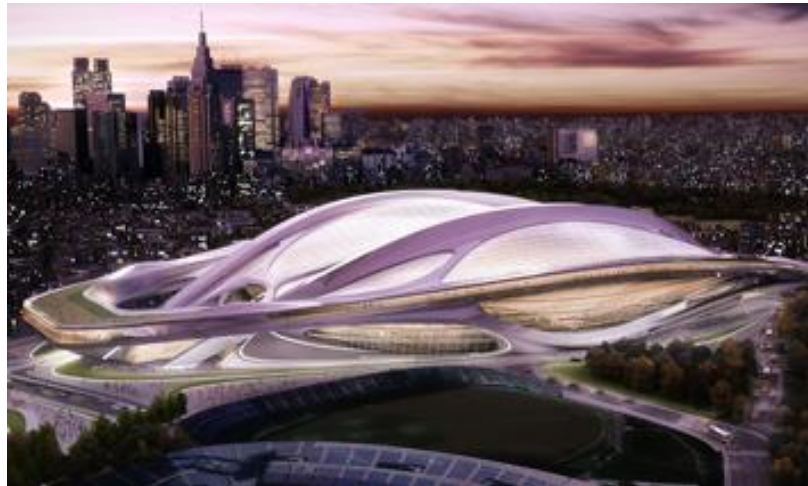

NEW NATIONAL STADIUM JAPAN (designed by competition 2013)
Reconstruction to be completed 2019.3
(Source : Japan Sport Council HP)



TOKYO SKYTREE(Open 2012.5)
The world's tallest broadcasting tower(634m)



The Olympic Village (Under planning)
(Source : TOKYO 2020 HP)

Cases of Smart Energy Network Expansion

-Cases of community development through smart energy networks continue to expand in various places in and around the Tokyo metropolitan area.

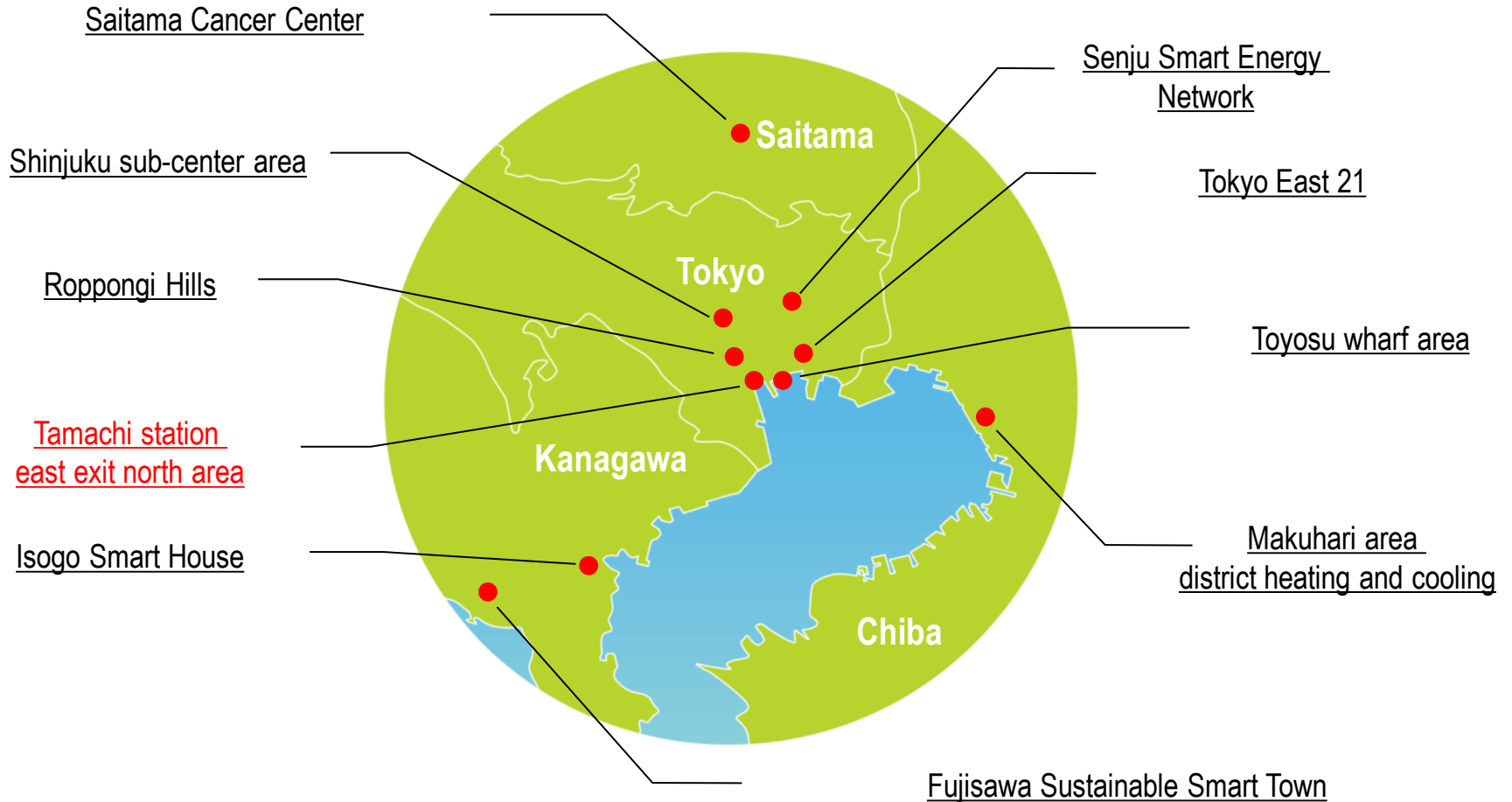

(Source : Tokyo Gas Co.)

Case2: Tamachi Smart Energy Network

-The development in front of the eastern exit of Tamachi Station is being promoted by Minato Ward and Aiiiku Hospital, which own buildings in the zone that has already been developed, as well as a private developer in the adjacent zone to be developed from now on and the DHC operator managing energy supply in the whole district. These parties are working together to **construct a smart energy network with a view to reducing carbon emissions in the district and making it more resilient to disaster.**

-A further aim is to make the energy system even more efficient through coordination between the No. 1 and No. 2 plants.

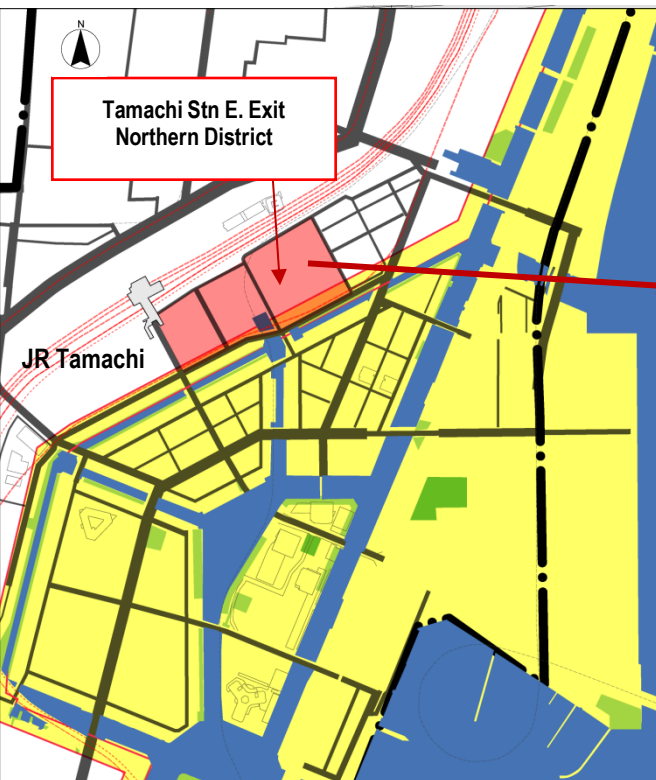

From "Guidelines on Urban Development around Shinagawa and Tamachi Stations" (Tokyo Metropolitan Government)

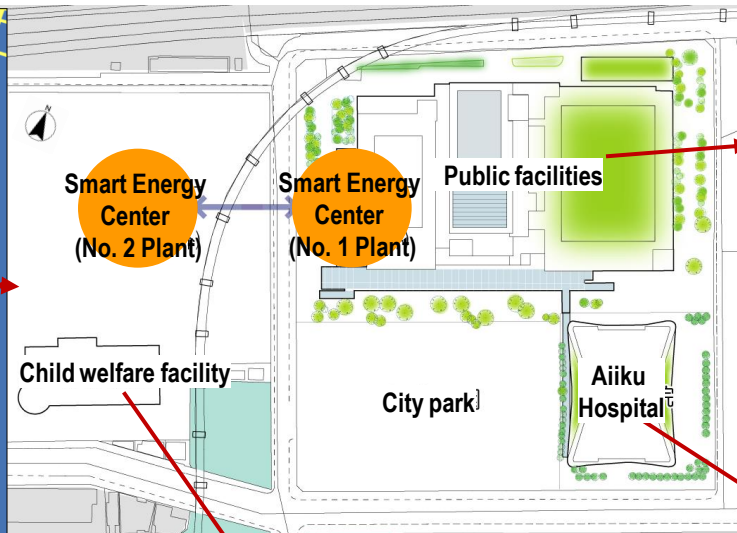

Public facilities: first phase to be completed in Oct. 2014 (Total floor space:51,000m2)



Aiiiku Hospital: to be completed in Oct. 2014 (Total floor space:18,000m2) (Source : Tokyo Gas Co.)



Child welfare facility: renovation to be completed in 2015 (presently Minato Ward Sports Center Swimming Pool) (Total floor space:7,000m2)

Energy system flow of Tamachi Smart Energy Network

- Use of high-efficiency gas engine CHP, fuel cells, and system consisting of the best mix of efficient heat sources
- Maximum adoption and effective use of solar thermal energy (STE), underground tunnel water, and other renewable and untapped energy sources
- The continuous (partial) supply of power and thermal energy even during grid power outages will enhance energy security.

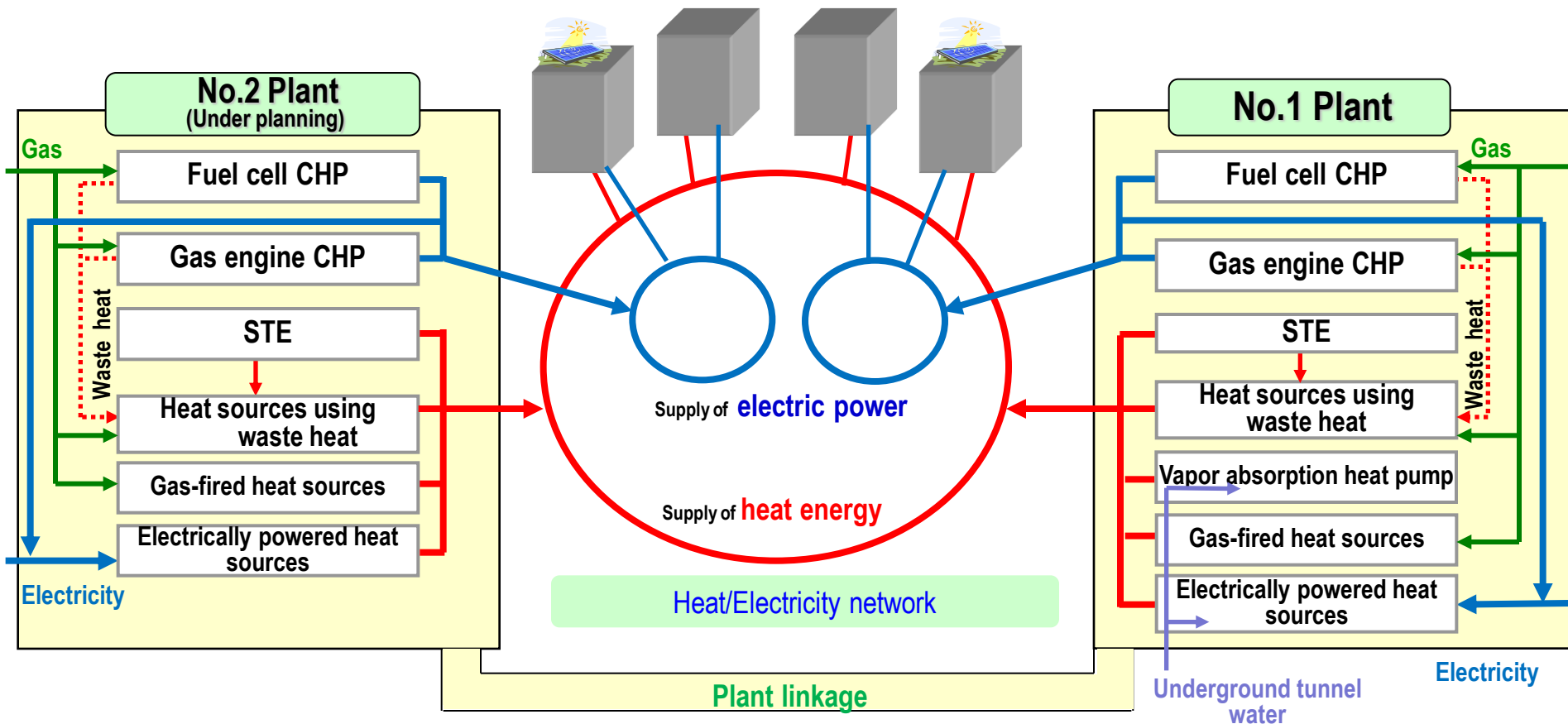

(Source : Tokyo Gas Co.)

Evolution into Next-generation DHC Systems

- The Tamachi Smart Energy Network rests on closer coordination between consumers as energy users and the Smart Energy Center based on extensive ICT application, in order to improve energy efficiency in the area as a whole and increase ability to cope with disasters.
- The DHC operator is expected to expand and provide services other than energy supply.

Conventional DHC systems

Improved consumer efficiency
Improved DHC efficiency

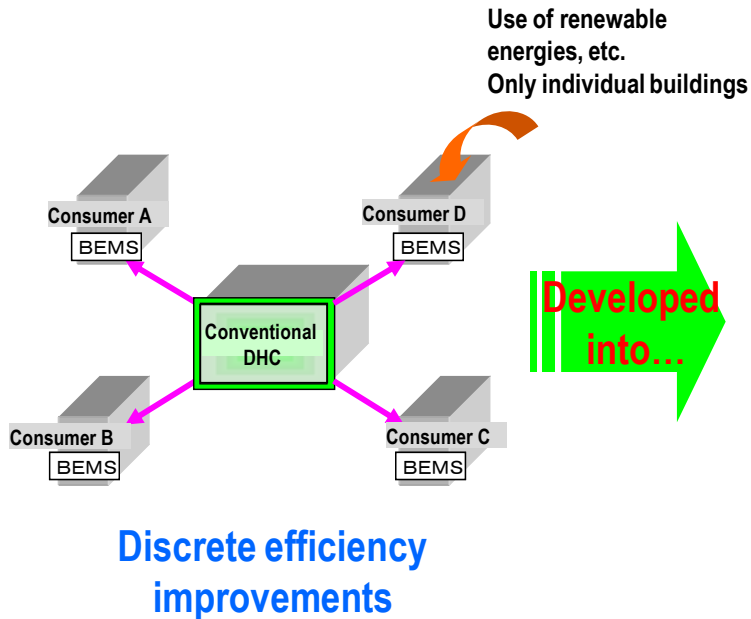

Next-generation DHC systems (smart energy network)

Optimized supply + demand = improved area efficiency

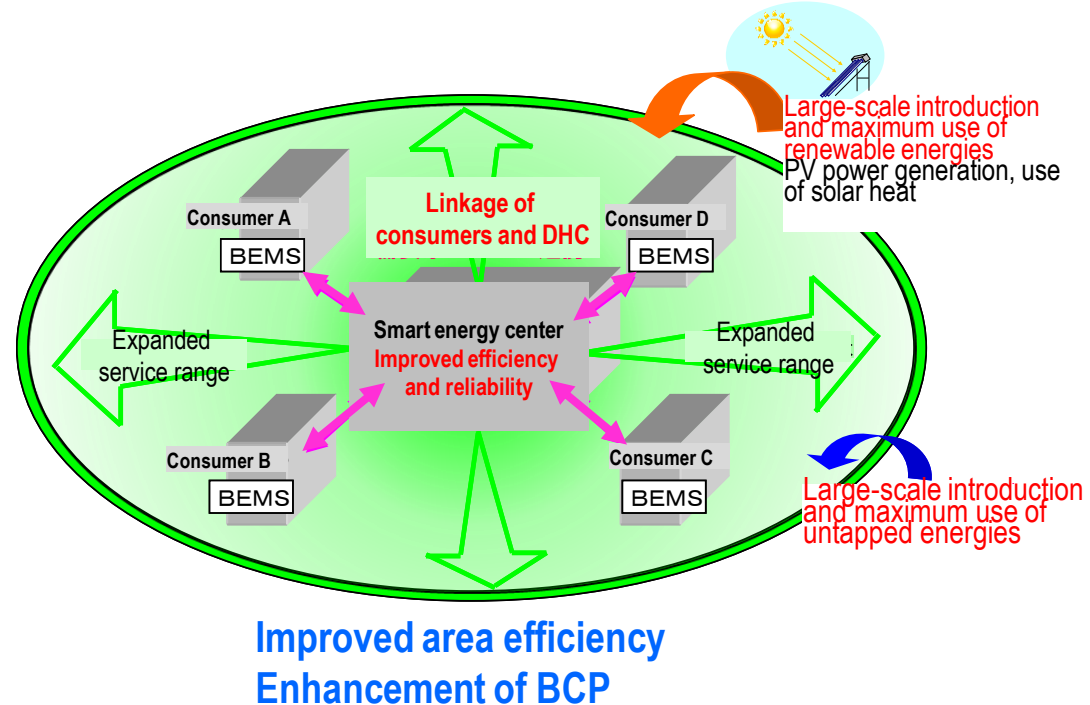

(Source : Tokyo Gas Co.)

4. Conclusion

- In Japan, there are rising expectations for a shift to natural gas in various fields of energy use. The promotion of CHP utilization was indicated in the revised version of the Basic Energy Plan, and the Basic Plan for Building National Resilience (draft) advises the input of stand-alone, distributed energy systems on local levels. Activity for the expanded diffusion of CHP and other distributed energy systems is consequently anticipated to quicken.
- Specific estimates were made of the level of CHP input to 2030 in each field. Attainment of the Roadmap targets requires further reduction in the initial cost (CAPEX) and running cost (OPEX). This calls for continued efforts on this front including policy-based incentives.
- For expanded diffusion of CHP from now on, it is vital to find new value apart from economic merit (cost savings) and environmental merit (reduction in energy consumption and CO2 emissions). With a focus on the value of the district and buildings, studies should be made on the CHP role and degree of social contribution also taking account of times of emergency (grid power outages) as well as normal times.
- A description was made of cases of construction of smart energy networks in the context of urban development, which are increasing in number in Japan. Adoption of smart energy networks can be induced by having the energy operator participate in community development right from the planning stage and giving all stakeholders a good understanding of the benefits of the networks, including their added value.

Thank you for your kind attention.