

europhysicsnews

The rainbow
Rotating Bose-Einstein condensates
Metrology: time for a new look...
Blue skies, blue seas
A conversation with Sir Peter Mansfield

37/1

2006

Volume 37 • number 1
Institutional subscription price:
99 euros per year



European Physical Society



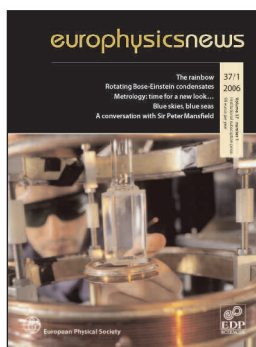

europhysicsnews

2006 • Volume 37 • number 1

cover picture: © CNRS Photothèque - MEDARD Laurence
 Laboratoire Aimé Cotton (LAC) • Orsay
 Experimental set up to obtain a cesium atom vapor Bose-Einstein condensate. Detail of the vacuum vessel and of magnetic coil traps.



▲ PAGE 12

Rotating Bose-Einstein Condensates



▲ PAGE 26

A conversation with Sir Peter Mansfield

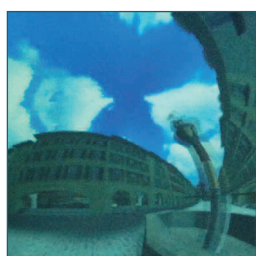

▲ PAGE 31

Museum review

EDITORIAL

- 05 About Europhysics Letters
 Denis Jérôme

NEWS

- 06 Position Paper on Physics Education
- 07 Nordic Network for Women in Physics
- 08 UNESCO Niels Bohr Gold Medal
- 08 2005: Hamilton's year (1805-1865)
- 09 Plasma Physics Division Conference and Hannes Alfvén Prize
- 09 Max Auwärter award 2006
- 10 The 18th IYPT in Winterthur (CH)
- 11 EPS in EC Partnerships: A new CD ROM and Web portal
- 11 Call for Individual Members
- 11 Letter

FEATURES

- 12 Rotating Bose-Einstein condensates
 F. Chevy and J. Dalibard
- 16 Blue skies, blue seas
 L.F.J (Jo) Hermans
- 17 The rainbow
 Owen Davies, Jeff Wannell, and John Inglesfield,
- 22 Metrology: time for a new look at the physics of traceable measurement?
 L.R. Pendrill

INTERVIEW

- 26 A conversation with Sir Peter Mansfield

MUSEUM REVIEW

- 31 Exhibition in Bern: "Meeting Einstein - Understanding physics"

BOOK REVIEW

- 32 Minding the Heavens, The Story of Our Discovery of the Milky Way
- 33 Capillarity and Wetting Phenomena: Drops, Bubbles, Pearls, Waves
- 33 Liquid Crystal Elastomers

euromphysicnews

euromphysicnews is the magazine of the European physics community. It is owned by the European Physical Society and produced in cooperation with EDP Sciences. The staff of EDP Sciences are involved in the production of the magazine and are not responsible for editorial content. Most contributors to euromphysicnews are volunteers and their work is greatly appreciated by the Editor and the Editorial Advisory Board. euromphysicnews is also available online at: www.euromphysicnews.com

37/1

2006

Volume 37 • number 1
Institutional subscription price:
99 euros per Year

Editor	Claude Sébenne EMAIL: Claude.Sebenne@impmc.jussieu.fr
Science Editor	George Morrison EMAIL: g.c.morrison@bham.ac.uk
Executive Editor	David Lee EMAIL: d.lee@eps.org
Graphic Designer	Xavier de Araujo EMAIL: designer@euromphysnet.org
Publication Director	Jean-Marc Quilbé , EDP Sciences

© European Physical Society and EDP Sciences

Schedule

Six issues will be published in 2006. The magazine is distributed at the end of January, March, May, July, September, November. A directory issue with listings of all EPS officials is published once a year.

Editorial Advisory Board

Chairman George Morrison

Members Alexis Baratoff, Giorgio Benedek, Marc Besançon, Carlos Fiolhais, Bill Gellely, Frank Israel, Thomas Jung, Karl-Heinz Meiwes-Broer, Jens Olaf Pepke Pedersen, Jerzy Prochorow, Jean-Marc Quilbé, Christophe Rossel, Claude Sébenne, Wolfram von Oertzen

Advertising Manager

Isaline Boulven EMAIL: boulven@edpsciences.org

Production Manager

Agnès Henri EMAIL: henri@edpsciences.org

Address EDP Sciences

17 avenue du Hoggar, BP 112,

PA de Courtabœuf,

F-91944 Les Ulis Cedex A • France

Tel +33 169 18 75 75 • **Fax** +33 169 28 84 91

Web www.edpsciences.org

Printer Printer RotoFrance • Lognes, France

Dépôt légal: Janvier 2006

Subscriptions

Individual Ordinary Members of the European Physical Society receive euromphysicnews free of charge. Members of EPS National Member Societies receive Euromphysic News through their society, except members of the Institute of Physics in the United Kingdom and the German Physical Society who receive a bimonthly bulletin. The following are subscription prices available through EDP Sciences. **Institutions** 99 euros (VAT included, European Union countries); 99 euros (the rest of the world). **Individuals** 58 euros (VAT included, European Union countries); 58 euros (the rest of the world). Contact subscribers@edpsciences.com or visit www.edpsciences.org

ISSN 0531-7479

ISSN 1432-1092 (electronic edition)

EPS Executive Committee

President Ove Poulsen, Aarhus

Vice-President Martin C.E. Huber, Villigen

Secretary Peter Melville, London

Treasurer Maria Allegrini, Pisa

Members Gerardo Delgado Barrio, Madrid

Berndt Feuerbacher, Cologne

Paul Hoyer, Helsinki

Hennie Kelder, Eindhoven

Maciej Kolwas, Warsaw

Anne-Marie Levy, Copenhagen

Zenonas Rudzikas, Vilnius

EPS Secretariat

Secretary General David Lee

Administrative Secretary Sylvie Loskill

Accountant Pascaline Padovani

EPS Conferences Patricia Helfenstein

Ophélie Fornari

Computer Engineer Ahmed Ouarab

Graphic Designer Xavier de Araujo

Europhysics Letters Yoanne Sobieski

Frédéric Burre

Alexandre Berthereau

Address EPS • 6 rue des Frères Lumière

BP 2136 • F-68060 Mulhouse Cedex • France

Tel +33 389 32 94 40 • **Fax** +33 389 32 94 49

Web www.eps.org

The Secretariat is open 08.00–17.00 CET except weekends and French public holidays.

EDP Sciences

Managing Director Jean-Marc Quilbé

Address EDP Sciences

17 avenue du Hoggar, BP 112,

PA de Courtabœuf,

F-91944 Les Ulis Cedex A • France

Tel +33 169 18 75 75 • **Fax** +33 169 28 84 91

Web www.edpsciences.org

EDITORIAL:

About Europhysics Letters

Denis Jérôme, Europhysics Letters Editor in Chief



This year, Europhysics Letters (EPL) will be celebrating its 20th anniversary. Historically, EPL is the result of a merger between two learned Society's letters journals (Journal de Physique Lettres and Lettere al Nuovo Cimento belonging respectively to the French and the Italian Physical Societies). It was supported by several National Physical Society members of the European Physical Society (EPS).

The aim of this merger was to launch a strong European-based journal for the publication of short and important communications in all domains of physics with a minimum of delay under the supervision and the scientific control of the EPS.

Twenty years after the creation of the journal, it is illuminating to recall the motivation which prevailed at the creation of EPL as expressed by G.H. Stafford, (the president of EPS in 1985): "Europhysics Letters marks an important milestone in the progress towards the greater unity in Europe which began with creation of the European Physical Society in 1968".

After 20 years of existence, the outcome of EPL is rather satisfying. 2005 was a good year. The number of submissions kept on increasing and the number of published papers reached 590 comprising over 4000 pages.

The visibility of the journal is large as it is distributed in all major science libraries over the world. It has also been greatly improved with the Web facilities. We can confidently claim that EPL has attained worldwide visibility.

The Editorial Board which is the essential core devoted to the evaluation of letters submitted presently comprises 32 highlevel scientists called the Co-Editors who are chosen for their recognised competence in their field of expertise and distributed over a large number of countries. Improvements will be made in 2006 adding Co-Editors from India and South America. Therefore,

EPL is proud to be present worldwide in all domains of physics. Let us hope that we have fulfilled the initial target fixed by N. Kurti, the first Editor in Chief of EPL: "Scientific publishing... is one of those matters at which it is desirable to handle on an international level".

Major progress has been achieved in order to increase the visibility of the articles namely, services offered to the authors and the subscribers such as the E-first publication in which the articles are published on the Web in final form citable by their DOI after acceptance (as soon as eventual corrections have been made by the authors on the PDF proofs). According to the 2004 statistics one third of the articles to EPL have been made visible on the Web through the E-first service in less than 14 weeks including the articles which have required serious revisions by their authors. The Latest-articles service which provides a free access to the full online version of the last two issues of EPL offers even more visibility to the journal. Last but not least, the visibility of the outstanding papers published by EPL will be boosted by the possibility offered by the journal of the European Physical Society, Europhysics News (EPN), with its circulation of nearly 25000 copies every two months to start a new section called "Highlights in European Journals". This operation should bring those papers to the attention of the community of physicists at large with the publication in EPN of a self-explanatory summary understandable by most of the readers of EPN. The journal is also cross-linked to other leading journals in the world through the Cross-Ref consortium.

But the year 2006 is more than an anniversary year. Indeed, this year, the different partners will be working on the new publication scheme for 2007 which will make EPL the only physics letters journal in Europe under the control of learned Societies.

The Institute of Physics through its publishing company (IOPP) will become an active partner in the publication of EPL, contributing to sales, distribution, marketing and also to editorial developments

representing EPL at major physics events with the help of an Executive Editor.

At the editorial level, several improvements are foreseen in the near future: the digitization of the EPL archives and of the precursor journals, a common portal website and the development of an on-line submission system improving the already existing possibility offered to the authors to submit their contribution through the HAL preprint server linked to arXiv (<http://hal.ccsd.cnrs.fr>).

Given the scientific and technical efforts made by the EPL Editorial Board and the expected improvements in the distribution scheme, we hope EPL follows the right track to become a leading vector for the European publication platform in Physics which was already anticipated by the EPS in 1985 (vide supra) and which is crucial for the development of Physics in the world.

We wish you a very happy and fruitful year 2006 and ask you once again to think of "EPL" for your best forthcoming letters. We are ready to help you! ■

Editor's desk

The Editorial team of Europhysics News wishes all its readers a **Happy New Year**. We would be delighted to receive your letters, opinions and comments about the content as well as the presentation of the journal. Those of general interest may be published, with the agreement of the author(s), within a 250 words limit.

Email to the Editor:

Claude.Sebenne@impmc.jussieu.fr, copy to g.c.morrison@bham.ac.uk, and to designer@europhysnet.org

Postal address:

The Editor,
Europhysics News, EPS, 6 rue des Frères
Lumières, 68200 Mulhouse, France

Position Paper on Physics Education

Ove Poulsen the EPS President has placed physics education at the top of his list of priorities. In February 2005, the Executive Committee held its 3rd *Journée de Réflexion* around this theme, with presentations from experts around Europe on analytical and statistical studies in attitudes towards science and technology, didactics, teaching methods and European initiatives. At Council in July 2005, delegates participated in a debate on EPS policy concerning issues in physics education. O. Poulsen with input from the Executive Committee and the Physics Education Division drafted a position paper on the importance of a solid physics education for all students, and outlined an action plan for the EPS in this field. A copy of the position paper as adopted by the Executive Committee at its meeting of 22 November 2005 is presented below. Other EPS position papers can be found at www.eps.org/papers_position/paper_index.html.

Position Paper on Physics Education

The European Physical Society emphasises the important role that Physics Education plays in today's society, and contributes to the promotion of physics education and a physics education system in Europe based on best practice and supported by appropriate physics education research.

A prerequisite for a sound industrial base in Europe and for the promotion and development of new technologies is inspiring and effective teaching of science in general, and physics in particular, at all levels in the educational system.

Science in general and physics in particular is one of the basic elements in our culture that sustain our communities. It is also a prerequisite for basic job skills and in many of our daily functions. Science and physics are also the foundation for the high technology revolution seen in our societies and the way such technologies influence other societal challenges such as the environment, energy supply, and communication and production technologies.

This requires a physics educational system with two important dimensions, one capable of delivering science and physics to all in elementary schools and especially in secondary schools (preuniversity), the

other a tertiary research-based educational system capable of training the next generation of scientists in ever increasing numbers, both for advancing science and for the needs of industry.

In the preuniversity educational system appropriate teacher training and in-service support are the most important factors. Didactics and curriculum development are central issues, both depending on advanced educational research. Science and physics teaching involves complex factors ranging from cognitive-, pedagogical-, didactics- to curriculum development. An important factor in sustaining student numbers is an improvement in the gender balance in physics studies at secondary school level.

The European Physical Society notes that it is crucial to:

- maintain and improve the quality of physics teaching and educational research at all levels across Europe,
- ensure rapid deployment of the results and best practices of educational research and experimentation, with regular contacts between educational researchers and the physics teaching community.

EPS calls on the national physics communities, on physics departments in universities and other institutes of higher education, as well as on national and European policy makers, to promote active research in physics education, in particular pilot projects for developing novel contents and methods, which should include the judicious use of new media. Associated with these research efforts there should be initiatives for improved training of specialists in physics education, including doctoral programmes and opportunities for further academic qualifications.

Tertiary level physics education, primarily taking place in universities, is an integral part of the European Higher Education Area (EHEA), the analogue of the European Research Area (ERA). The aim of EHEA is a harmonisation of the higher education systems in Europe, facilitating better utilization of available resources, better opportunities for students to study abroad and to connect the European educational area more strongly to employment. The Bologna process prescribes the development of EHEA.

The European Physical Society:

- welcomes the Bologna process and the creation of EHEA, that provides scope for greater European cooperation and development in higher education, to the benefit of both European and foreign students
- warns against overregulation of degrees and their component parts, and stress the need only for a general framework – “light touch regulation”
- recommends expression of learning outcomes and competencies in general terms without over prescribing each learning module
- stresses that physics learning is cumulative and that it cannot be broken down into modules to be chosen completely free. In particular the early years of a physics degree will contain many compulsory modules, which are necessary prerequisites for later work.

The Bologna declaration describes a three-level educational system, at bachelor, master, and doctoral level.

The European Physical Society recommends that:

- Bachelor degrees in physics should have a large common content to facilitate student mobility between universities and countries, both during and after the bachelor programme
- Masters degrees need to be more varied and involve specialisation in particular areas of physics or combinations of physics with related disciplines
- Doctoral degrees should not be modularized or expressed in specific learning outcomes/competencies, except possibly for some minor components.

To support these recommendations EPS will:

- inform physics professors, lecturers and teachers of what is happening across Europe,
- promote the establishment of a Euro Bachelor label in physics as a quality mark for bachelor degrees to assure national or European regulators about the degree quality,
- promote the dissemination of educational pilot projects in physics to further best-practice,
- endeavour to avoid inappropriate competition between funds for physics research and physics education research. ■

Nordic Network for Women in Physics

Cathrine Fox Maule,

PhD student, chairperson of Women in Physics in Denmark • Niels Bohr Institute, Juliane Maries vej 30 • 2100 Copenhagen Oe.

On August 10th more than 100 primarily female physicists from the Nordic countries founded a Nordic Network for Women in Physics (NorWiP). This occurred at the 1st Nordic Workshop for Women in Physics, which was sponsored by NordForsk. The purpose of NorWiP is to create contacts between female physicists for exchanging information and knowledge. The network will work to increase the visibility of female physicists, and to identify and remove gender barriers for women pursuing a career in physics.

NorWiP will act as an umbrella organization for the national networks of female physicists in the Nordic countries. Denmark and Sweden have very active networks, whereas the Norwegian network has been inactive in past years. However, after the 1st Nordic Workshop for Women in Physics held in Bergen August 8-10th, the Norwegian network is being re-established and a Finnish network is being started. NorWiP is going to act as a coordinating forum where the national networks can exchange ideas and strategies for obtaining their common goals.

The number of female physicists with permanent positions at the Nordic universities is so low that it is very difficult for

young women to find female role models within their own discipline in their own country. By increasing the local networks of female physicists to a Nordic network, the pool of potential role models will be increased. To facilitate contacts NorWiP is generating a data base of female physicists from or working in the Nordic countries. The data base contains brief biographical information about the scientists and can be used to find female physicists within specific disciplines of physics either for collaboration, for invited speakers, or to sit in advisory committees, etc. The web site will also contain additional information of relevance, as e.g. a notice board of available positions and stipends and links to conferences regarding women in science (gender-related conferences).

Besides the web site and the data base, the ambition for NorWiP is to hold a conference for all members every two or three years depending on funding. These meetings will, like the 1st Nordic Workshop for Women in Physics, have a scientific program, but also include talks on gender issues and workshops of relevance especially for the young scientists concerning, for example, proposal writing or how to give good talks.

The president of the European Physical Society (EPS), Ove Poulsen, is happy about the new network. "The European Physical Society (EPS) welcomes NorWiP. The ROSE investigation shows that student involvement in science education is weak. One of the more distinct findings is the weak interest of girls and young women in science-related issues. This is not an acceptable situation, neither from a democratic nor from a professional point of view. The formation of NorWiP is a most welcome initiative as it highlights these issues and supports the further development of physics. Physics is changing rapidly these years, not only professionally, but also sociologically due to the high average age of staff physicists. In the coming years it is important to focus on a diverse recruitment to physics. NorWiP supports this development by emphasising the importance of persuading talented women to enter physics, and equally importantly, to stay in physics," says Ove Poulsen.

The first board of NorWiP consists of Dorte N. Madsen (Norway), Karin N. Andersen (Denmark), Elisabeth Rachlew (Sweden) and Katri Huitu (Finland). NorWiP is funded by the Danish Natural Research Council. For more information about NorWiP visit www.norwip.dk. ■

UNESCO Niels Bohr Gold Medal

The attribution of the UNESCO-Niels Bohr Gold Medal is a very occasional event in physics. It was thought that it should occur in 2005, the World Year of Physics. Under the initiative of the Danish UNESCO National Commission, chaired by H.S. Gaardhoeje (right in the picture), it was awarded to three outstanding international Scientists. They received their Certificates, signed by Koichiro Matsuura, Director General of UNESCO, during a ceremony at the Danish Academy of Science on the 15th of November 2005 from the Danish Minister of Science Helge Sander (left). They are:

- Professor Herwig Schopper (second from the right) from CERN (Switzerland), in recognition of his outstanding contributions to the development of accelerator-based particle and high energy nuclear physics and to the strengthening of international cooperation in basic physics

research through CERN and SESAME. Prof. H. Schopper is President of the SESAME Council and former Director General of CERN. He has been President of the German Physical Society and of the European Physical Society.

- Professor Peter Zoller (third from the

left), University of Innsbruck, a specialist in Quantum Information and Quantum Mechanics.

- Professor Sir Martin Rees (second from the left), University of Cambridge, astrophysicist and cosmologist making research about Space, its beginning and future. ■



© Hasse Ferrolid

2005: Hamilton's year (1805-1865)

Luke Drury,
Dublin Institute for Advance Studies

At midnight between the third and fourth of August 1805 in Dominick Street, Dublin, the wife of a minor lawyer and land agent, Archibald Hamilton, gave birth to a boy. His mother, Sarah Hutton, was of Huguenot extraction and came from a well-known Dublin family of coach builders. His father was a close friend (and possibly the natural son) of the patriot Archibald Hamilton Rowan after whom the boy was named William Rowan Hamilton. Today, two hundred years on, the year 2005 has been declared to be the "Hamilton Year celebrating Irish Science" to mark the bicentenary of his birth and a special 10 € commemorative coin has been issued by the Irish central bank. But who was Hamilton and what did he do to be commemorated in this way? The answer is simple. Hamilton was certainly the greatest mathematician, and arguably the greatest scientist, that Ireland has produced to date.

Hamilton first came to fame while still an undergraduate at Trinity College Dublin with a remarkable paper on "Systems of Rays". He also won virtually all available prizes and distinctions and on the basis of his evident ability and promise was appointed Professor of Astronomy in 1827 even before graduating! Although he did his best, at least initially, to fulfill the observational duties attached to the post Hamilton was an indifferent astronomer and his claim to fame rests solely on his contributions to mathematics and theoretical physics. Here however his reputation is secure and rests in particular on two major advances in totally unrelated fields, dynamical systems and pure algebra.

The first grew out of his early work on optics. In his "System of Rays" and subsequent papers Hamilton developed a general mathematical description of all possible systems described by geometrical optics, starting from Fermat's variational principle of least time. Basically what Hamilton showed was the very remarkable result, that the entire optical system and all solutions for paths of light rays through the system could be completely described by one characteristic function. Actually calculating this function for a real system can be very difficult, but the mere existence of such a function, and the fact that it satisfies certain equations, allows one to state many general results about all optical systems. It also led

Hamilton to deduce the existence of a totally new optical phenomenon, conical refraction. This was the first prediction of a new physical effect on the sole basis of the mathematical structure of a theory and immediately established Hamilton's international reputation.

Hamilton developed his general theory in the context of geometrical optics, but as he was well aware it could also be applied to mechanics, where again the classical dynamics of very general systems can be shown to obey a variational principle. In his two great papers on his "General method in dynamics" he develops this idea, first establishing the proper form of the variational principle in terms of what we now call the classical action, then showing that all such systems can be written in a particularly simple canonical (or Hamiltonian) form and finally demonstrating the existence of a principal function from which all the solutions of the dynamical equations can be derived. This work formed the basis for all subsequent work in theoretical mechanics and, remarkably, was found to be precisely the tool needed in the early days of quantum mechanics.

Hamilton's second great achievement was in the area of abstract algebra. Unlike most of his contemporaries he believed passionately that mathematics, and indeed all science, had to have a philosophical foundation which in his case he found in the works of Kant and Coleridge. In particular he convinced himself that just as geometry, in Kant's philosophy, derived from our innate perception of space and was the science of pure space, so algebra should be the science of pure time. Whatever the merits of this idea (and even Hamilton was eventually forced to admit that it did not really work) it did enable him to contemplate the possibility of an algebra where multiplication was non-commutative. This was the crucial element needed for his discovery of quaternions, the inspiration for which famously came to him while walking along the banks of the royal canal on his way into Dublin from Dunsink. He immediately scratched the fundamental formulae of quaternion mul-

tiplication onto the stone of Broome Bridge and, although his original act of vandalism is long decayed away, a plaque now marks the spot and is the scene of an annual pilgrimage by mathematicians. His discovery opened peoples' minds to the possibility of more general algebraic structures and led within a decade to an explosion of new and important ideas. The modern vector calculus, used by every physicist and engineer, also derives directly from quaternions (the very terms vector and scalar were invented by Hamilton).

It was a mark of the international respect that Hamilton enjoyed during his own lifetime that when the American National Academy of Sciences was established and proceeded to elect its first foreign associates the very first person elected, on 9 January 1865, and therefore by implication the person the American academy considered to be the then greatest living non-American scientist, was Hamilton. Hamilton received the news of this honour shortly before his death in Dunsink on 2 September 1865.

About the author

Luke Drury is Senior Professor in the Dublin Institute for Advance Studies, and (honorary) Andrews' Professor of Astronomy in Trinity College Dublin. He coordinated the Hamilton Year activities under the auspices of the Royal Irish Academy. ■



▲ Fig. 1: the special 10 € commemorative coin.

Plasma Physics Division Conference and Hannes Alfvén Prize

The 32nd Annual Conference of the Plasma Physics Division of the European Physical Society was held from 27 June to 1 July 2005 at Tarragona (Spain) and organised for the division by CIEMAT and the Universitat Rovira i Virgili of Tarragona. During the conference opening session, the Hannes Alfvén Prize was awarded to Malcolm Haines, Tom Sanford and Valentin Smirnov *“for their major contributions to the development of the multi-wire array in Z-pinch pulse-power physics; the X-ray yield was rapidly increased to the level of 2 Megajoule starting with pioneering work on the “Angara” facilities in Russia, through the “Saturn” project in the Sandia Laboratories to the present “Z” device also in Sandia, strongly supported by the rapid evolution of the underlying theory of cylindrical wire-array liner compression”*

Laudation for Malcolm Haines, Thomas Sanford and Valentin Smirnov

Malcolm Haines, Tom Sanford and Valentin Smirnov have individually contributed to one of the fastest developments in Plasma Physics during the last decades. The quest for stabilising a Z-pinch implosion had led to the idea of using a cylindrical foil rather than a simple plasma column. Under Academician Valentin Panteleimonovich Smirnov, the Angara-5-1 pulsed power Z-pinch was built in 1984 at the Troitsk Institute for Innovation and Fusion Research. They developed a novel two-shell liner in which the outer shell transferred its imploding energy to the inner shell when they collided, leading to a high re-radiation

towards an inner target. During the period 1989-1992, the X-ray emission reached 40kJ in a pulse of 4 nanoseconds, opening up studies of materials with extremely high energy densities. The success of these experiments surprised visiting American scientists in 1993. The ideas of concentric wire arrays then originated in Troitsk. Professor Malcolm Haines subsequently worked on modelling the implosion of concentric liners and of wire arrays, searching for an understanding of the improved stability, shorter pulses and higher implosion yields, in conjunction with experiments at the MAGPIE facility at Imperial College. This work led to increasingly detailed parametric models of these configurations and to new ideas on the design of these wire arrays. The « Saturn » facility and then the larger « Z » facility were constructed in Sandia Laboratories, and there was a standing-room-only presentation in a remote room at the EPS conference in Prague in 1998 where the European scientists were able to appreciate the new results from this team, in which Dr. Tom Sandford was the driving force. The 20 Mega-ampère « Z » facility has now reached radiation energies of nearly 2MJ during short pulses of 6 nsec, providing world record radiated power of over 200TW, with exciting potential for inertial fusion research. The success of these three scientists has led to new concepts for single- and double-ended hohlraum illumination, novel methods of imploder design and astonishing electrical to radiated energy conversion efficiencies of 15%. The award of the Hannes Alfvén Prize in 2005 to these three scientists

underlines the unusually rapid development and transfer of knowledge and understanding in our field of Plasma Physics.

At the same conference, the PhD Research Award was introduced for the first time. An international committee selected two Prize Winners for 2005, Bruno Gonçalves (IST, Portugal) and cited *“... and notes his interaction with several research teams during his work and his involvement in a commendable number of publications and conference contributions...”* and Pavel Popovich (CRPP, Switzerland) citing *“... and commends his authoritative discussion of both the physics involved and the computational aspects...”*.

Jo Lister

Chairman Plasma Physics Division

Max Auwärter award 2006

The Max Auwärter Foundation in Balzers, Principality of Liechtenstein offers bi-annually the Max Auwärter Award for students and young scientists at universities, vocational colleges and other research institutions, who have published *as single author* relevant work in the fields of *surface physics, surface chemistry and organic or inorganic thin films*. The award includes a citation and a prize-money of € 10,000 (ten thousand euro) and may be split between several candidates.

Applications or proposals for the Max Auwärter award 2006 should be submitted with four copies of the publication to be considered and the curriculum vitae of the proposed recipient(s) describing his/her/their previous scientific activities by May 15, 2006 at the latest to Prof. Hannspeter Winter, Institut für Allgemeine Physik, Technische Universität Wien A-1040 Wien, Wiedner Hauptstrasse 8-10/134 • Fax: +43 1 58801 - 13499 • e-mail: winter@iap.tuwien.ac.at. A jury appointed by the foundation Council will decide finally and indisputably about the awarding of the prize.

▼ Fig. 1: (photo of the Hannes Alfvén Prize Winners, courtesy CIEMAT)

Left to right. Malcolm Haines, Tom Sanford, Valentin Smirnov



The 18th IYPT in Winterthur (CH)

Gunnar Tibell,
President of the IYPT International Organising Committee

IYPT, the International Young Physicists' Tournament, organised its 18th event in Winterthur, Switzerland, July 14 – 21, 2005, financially supported by the European Union, the City of Winterthur and several other private and public sponsors. The 25 teams in competition came from 23 different countries. The five members of each team have normally just finished the final year of upper secondary school, i.e., they enter university or other tertiary education in the following autumn.

The 17 problems to be discussed in the tournament were published last year, about a month after the previous event which was held in Brisbane, Australia. Some examples of problems are the following:

2. Two balls placed in contact on a tilted groove sometimes do not roll down. Explain the phenomenon and find the conditions, under which it occurs.

4. When a smooth column of water hits a horizontal plane, it flows out radially. At some radius, its height suddenly rises. Investigate the nature of the phenomenon. What happens if a liquid more viscous than water is used?

12. Spin can be used to alter the flight path of balls in sport. Investigate the motion of a spinning ball, for example a table-tennis or tennis ball, in order to determine the effect of the relevant parameters.

14. When you apply a vertical magnetic field to a metallic cylinder suspended by a

string it begins to rotate. Study this phenomenon.

16. Granular material is flowing out of a vessel through a funnel. Investigate if it is possible to increase the outflow by putting an obstacle above the outlet pipe.

17. A transparent vessel is half-filled with saturated salt water solution and then fresh water is added with caution. A distinct boundary between these liquids is formed. Investigate its behaviour if the lower liquid is heated.

It is evident that the problems are of the "open" type, with no unique answers. Instead the advantages and disadvantages of solutions presented can be discussed between the participating teams. They also require both theoretical and experimental work during the months that the teams prepare for their appearance in an IYPT event.

Five qualifying rounds, or "selective fights", are set up according to the regulations of the Tournament, each containing three teams rotating through the roles of reporter, opponent and reviewer in each fight. The opponent challenges the reporting team for one of the 17 problems. The reporter can refuse to accept the challenge, but after three such refusals the grade for the performance will be reduced. A selective fight takes about three hours.

With 25 teams competing in Winterthur it was necessary to have four teams in certain

fights; in such a case, according to the regulations, the teams rotate through an additional passive role. Even so, all teams assumed the rôles of reporter, opponent and reviewer altogether five times during the four days of selective fights. An international jury judged each performance of the teams, on a scale from 0 to 10. After summing the points achieved, the conclusion of the jury members turned out to be that the teams from Germany, Belarus and U.S.A. would be competing in the final.

In the final, held at the University of Zürich Irchel, the three teams could choose which of the 17 problems to present. After a very even and intense final round the German team scored the best, very closely followed by the team from Belarus. The U.S.A. team came in third. The teams had chosen problems 12, 4, and 16, respectively. More details can be found on links from the IYPT home page: www.iypt.org

In accordance with the regulations of the IYPT there were also some cultural events arranged by the Local Organising Committee, whose chairman Wolfgang Pils is a teacher at the competition venue, Kantonsschule Im Lee. One excursion gave us a chance to see the magnificent Technorama in the outskirts of Winterthur. This house also served as the venue for the opening ceremony. A full day was devoted to a climb in the neighbouring mountains. The day after the final ceremony the International Organizing Committee was invited to the Swiss National Accelerator Centre, PSI in Villigen. In addition to seeing the installations for physics and medical research we were also reminded of the Einstein centenary by a small exhibit. It should be emphasized that by placing IYPT in Switzerland in 2005 we all felt part of the World Year of Physics. What happened in this country 100 years ago, when Einstein published his miraculous papers, was actually the whole reason for celebrating. In the IYPT community we are grateful to our hosts for the generous invitation.

In 2006 the IYPT competition will be held in Bratislava, Slovakia, and the problems to be discussed there have been published on the home page. ■



◀ Fig. 1: An atmosphere of concentration during the competition at the "International Young Physicists' Tournament".

© Samuel Byland

EPS in EC Partnerships:

A new CD ROM and Web portal

Members of the European Physical Society will - or certainly should - know of the Society's considerable and fruitful involvement in several physics education and public awareness projects within the EC's Framework Programmes. A number of these successful ventures have been in collaboration with the double Pirelli Award-winning team, based at the National Institute for the Physics of Matter (now CNR-INFM) in the University of Parma, Italy.

A five-language interactive CD-ROM and its linked web portal have just been created, which deals with wide-ranging aspects of energy and semiconductor physics. The very new, exciting and extensive interactive programme includes "Man's Conquest of Energy", dealing with our use of energy down the ages and the current dilemmas faced by all of us with regard to the production and use of energy in a sustainable manner. The programme is objective and scientific in its approach.

WESPA is the EC acronym for "A Web Portal for Energy and Semiconductor Pub-

lic Awareness". The languages in which the CD ROMs and website are available are Italian, English, Spanish, German and French.

As with their other much praised productions, the Parma team have made these available on a not-for-profit basis.

Copies of the CD-ROM versions will automatically be received by those people who so kindly evaluated and commented upon the trial versions. For the possible availability of a limited number of free copies of the CD-ROM, the supply of which will be prioritised first for schools and universities and groups or organisations concerned with bringing awareness of science and its issues to the general public, please contact Professor Roberto Fieschi on fieschi@fis.unipr.it

To access the material on-line, please go to <http://informando.infm.it/wespa>.

Further information regarding the English-language version may be obtained from: brian.davies@sciencewords.demon.co.uk ■

Roberto Fieschi

Call for Individual Members

John Beeby,

(IOM representative on Council, 2002 – 2005)

Individual Members (IMs) of the European Physical Society, formerly called Individual Ordinary Members (IOMs), are an important part of the EPS community. Three components make EPS, one is made of National Societies, the second of Associated Members and the third of IMs. Although members of national societies affiliated to the EPS belong automatically to the EPS, joining as an IM is a way of showing directly individual concern and support for the ideals and aims of the EPS. It is also the way to participate directly into the activities of, and even to lead, one of the various committees, divisions, groups, etc. which justify the existence of EPS. It is among IMs that EPS Fellows are distinguished (see *Europhysics News* 36/2, p.68, 2005)

It is not expensive to be an IM, especially since the cost was reduced last year to 15 €.

So this presents a good opportunity for physicists to join and to encourage their colleagues to do the same. One advantage is that in some regions, for example Germany, the UK and Ireland, only IMs receive *Europhysics News*. More importantly, as an IM you are now represented on Council by five elected members, currently M. Benedict, Hungary (benedict@physx.u-szeged.hu), V. Malka, France (victor.malka@ensta.fr), R. Menzel, Germany (menzel@rz.uni-postdam.de), F. Schwabl, Germany (schwabl@ph.tum.de) and F. Vedel, France (fernande.vedel@up.univ-mrs.fr) and through them can have an influence on Council decisions. They are always pleased to hear from IMs about proposals and issues affecting them which, if appropriate, they can raise or comment on directly at Council. Application forms for IMs are available at www.eps.org. ■

Letter

From André Martin (CERN) about the pentaquark, some historical precisions:

Dear Editors,

After reading the article on the pentaquark by K. Goeke, H.C. Kim, M. Prasalowicz in *Europhysics News* 36 n°5, 151 (2005)... let me try to put some historical details back as they are.

1) The SU3 (flavor) group with the Baryon-Meson Octets was proposed by Gell-Mann in 1961, and also by Ne'e-man. Zweig had **nothing to do** with that.

2) The prediction of the Ω^- particle was made by Gell-Mann on the basis of the symmetry breaking of an SU3 decuplet, at the Geneva conference in 1962, during the discussion session after the review of Baryon spectroscopy by George Snow (I was present!).

3) Many distinguished theoreticians were sceptical about the prediction of Gell-Mann, especially concerning the MASS of the Ω^- particle. However in January 1964 Nick Samios and his friends discovered the Ω^- particle at exactly the right mass within experimental errors.

4) The quark model was proposed in 1964 on both sides of the Atlantic (Gell-mann was in Caltech and Zweig was at CERN). Gell-Mann also acknowledges a conversation on that subject with R.Serber in March 1963.

It is true that the remarkable equal spacing of the baryon decuplet is now best understood in terms of a model with constituent quarks interacting through a flavor independent central potential, plus spin dependent contributions. See for instance J-M.Richard, *Physics Reports*, 212, 1 (1992). ■

letters, opinions and comments?

Write to the Editor:

Claude.Sebenne@impmc.jussieu.fr, copy to g.c.morrison@bham.ac.uk, and to designer@europhysnet.org

Postal address: The Editor, *Europhysics News*, EPS, 6 rue des Frères Lumières, 68200 Mulhouse, France

Rotating Bose-Einstein condensates

F. Chevy and J. Dalibard,

Laboratoire Kastler Brossel, Département de Physique de l'École Normale Supérieure, 24 rue Lhomond • 75005 Paris • France

At low temperature Quantum Physics can manifest itself at the macroscopic scale in many spectacular ways. Some of its most remarkable features occur when a fluid is stirred. Indeed, as a consequence of the existence of a macroscopic wave-function describing the system, a quantum fluid cannot sustain rigid body rotation by contrast with a classical fluid. Rather, the stirring generates quantized vortices. The recent observation of novel quantum fluids formed by ultra-cold atomic gases allows us to revisit the properties of vortex systems, and to address pending questions of condensed matter physics.

Quantum physics tells us that particles can be classified into two families called respectively bosons and fermions. The fermions like the electrons have a half-integer spin and obey the Pauli Principle, according to which no two identical fermions can occupy the same quantum state. By contrast, bosons have an integer spin and they can occupy the same state. Following the work of S.N. Bose on blackbody radiation, A. Einstein showed in 1924 that this gregarious bosonic trend leads at low temperature to a phase transition for a gas of independent particles, the Bose-Einstein condensation. The condensation threshold is reached when the quantum statistics effects start to be prominent, i.e. when the interatomic distance is of the order of the coherence length of the matter waves. The Bose-Einstein condensate which forms below a critical temperature contains a macroscopic number of particles, all occupying the same quantum state. These particles are thus described by the same macroscopic wave function and the system constitutes a so-called *quantum fluid*. Quantitatively the Bose Einstein condensation in an ideal gas occurs when the temperature T and the atomic density ρ satisfy the relation

$$\rho \Lambda_{dB}^3 \simeq 2.6 \quad (1)$$

where $\Lambda_{dB} = \hbar \sqrt{2\pi} / \sqrt{mk_B T}$ is the thermal wavelength, \hbar and k_B are the Planck and Boltzmann constants, and m is the mass of a particle.

Einstein's prediction for a phase transition in a non interacting gas was first considered dubious by some physicists, and it remained unproved experimentally for more than ten years. Finally in 1938, Kapitza, Allen and Misener showed that the viscosity of liquid helium vanishes suddenly below 2.17 K. London immediately related this superfluid behaviour with Einstein's prediction. This discovery constitutes a milestone in the history of statistical physics. It marked the beginning of a fruitful research, in which many of the greatest physicists of the middle of the 20th century, such as L. Landau or R.P. Feynman, were involved. Despite some major successes, the theoretical understanding of superfluid helium remained however severely hindered by the strength of the atomic interactions in a liquid phase. The physics of liquid helium is indeed very far from the ideal gas situation considered by Einstein, which makes any *ab initio* prediction very difficult.

Gaseous Bose-Einstein Condensates.

A recent breakthrough in the history of quantum fluids was the observation in 1995 of the first gaseous Bose-Einstein condensates [1,2]. This major finding was achieved by the groups of E. Cornell and C. Wieman at Boulder, and a few months later by W. Ketterle at MIT, using rubidium and sodium atoms, respectively. These three physicists were awarded the 2001 Nobel Prize in physics for this discovery. With these systems it became possible to study Einstein's prediction in a regime of low density, thus very close to the situation addressed in the 1924 article [3-5].

These experiments have now been reproduced using several other atomic species. A few different recipes to achieve quantum degeneracy exist, but they are all based on the same basic tool called *evaporative cooling*. The atoms are trapped in a potential well, created either by a magnetic field or a focused laser beam, that one deliberately truncates at energy U_i . Consider an elastic collision between two trapped atoms: if the final energy of one of the two partners is larger than U_i , it can escape from the trap. Thanks to the repetition of such processes, the energy of the remaining particles decreases and the gas thermalizes at a temperature of the order of a fraction of U_i / k_B . The sample is cooled even further by decreasing slowly the value of U_i . When the elastic collision rate between trapped atoms is large enough, the ratio T/U_i stays constant as U_i decreases, and the condensation threshold can be reached.

In the experiments described below, we start with a rubidium vapour at room temperature. Using standard laser trapping techniques, we confine and cool 10^9 atoms in

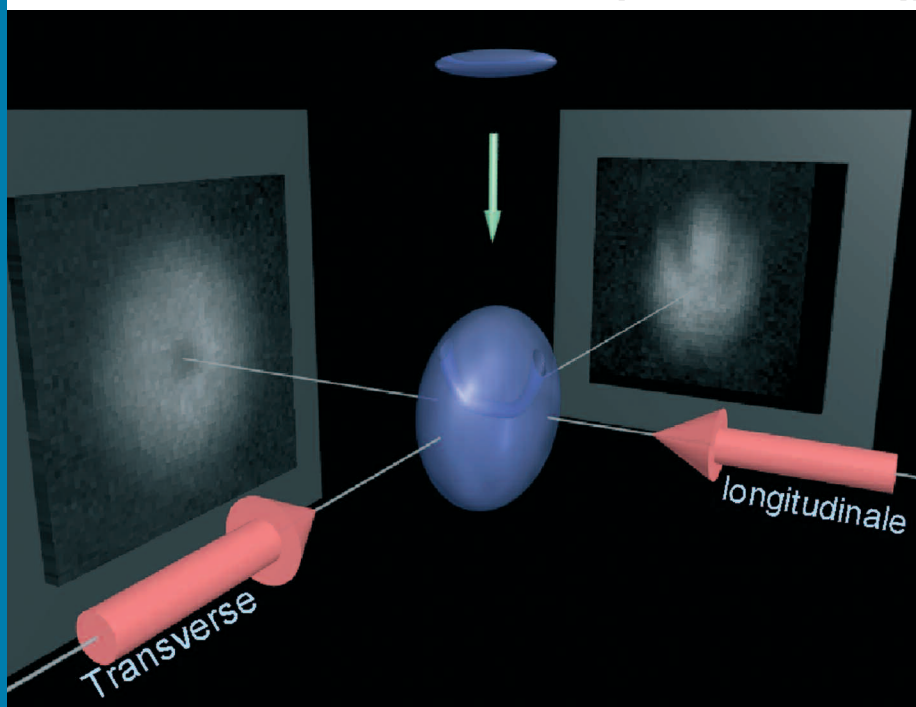

◀ **Fig. 1:** Absorption imaging scheme. The trapping potential is switched off abruptly, letting the cloud fall and expand. We measure the absorption of two beams propagating in directions parallel and perpendicular to the symmetry axis of the trap. The laser beams are resonant with the atomic resonance transition and the density profile of the cloud is obtained from the absorption of light by the atoms.

► **Fig. 2:** Principle of the atom spoon. We shine two laser beams (red) on the trapped atoms (yellow cigar sitting at the center of the white and blue coils that create the magnetic trapping potential). The combination of the two beams creates an optical potential whose axes rotate along the z axis at an angular velocity Ω_0 .

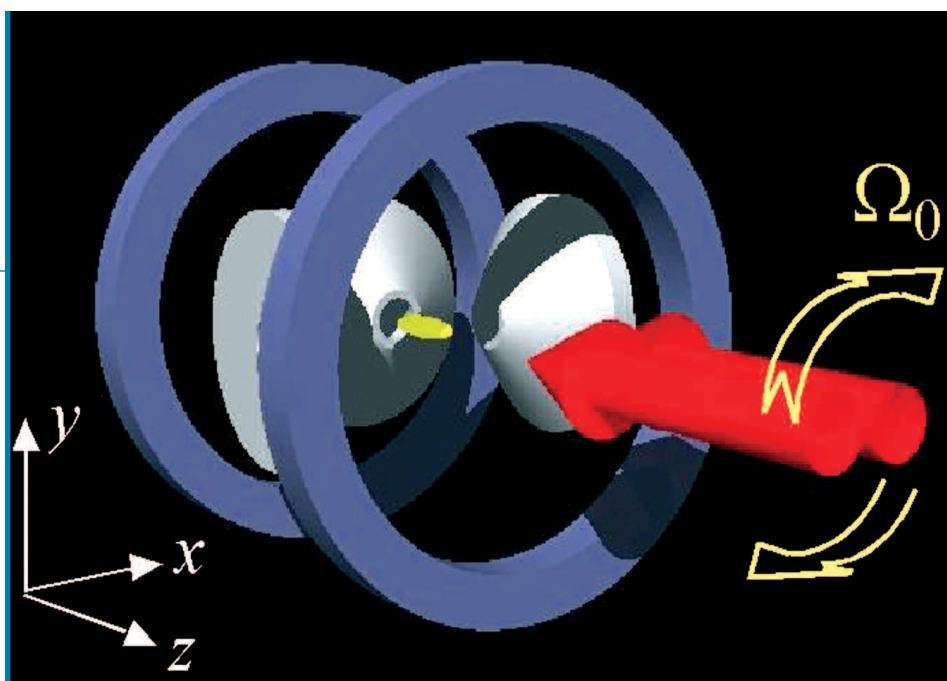

a magneto-optical trap, and we transfer them in an elongated, cylindrically symmetric magnetic trap. The longitudinal and transverse frequencies of the trap are typically $\nu_{\parallel} = 10$ Hz and $\nu_{\perp} = 100$ Hz, and the initial temperature of the atom cloud is 200 microkelvins, corresponding to a phase space density $\rho\Lambda^3_{dB}$ of 10^{-6} . After a 20 second evaporation phase, we reach the threshold (1) of Bose-Einstein condensation at a temperature $T_c \sim 500$ nK. By pushing the evaporation a bit further, we produce

a quasi-pure condensate with $N_c \sim 3 \cdot 10^5$ atoms. The cloud is cigar shaped, with a $100 \mu\text{m}$ length and a $10 \mu\text{m}$ diameter. The atoms are observed by measuring the absorption of a resonant probe laser beam: we image the shadow imprinted by the atoms on this probe beam onto a CCD camera. In order to obtain a good spatial resolution, we switch off the trap abruptly and let the cloud expand freely for 25 ms before shining it with the probe laser. During this free fall, the transverse dimensions of the cloud are scaled by a factor 15, while the longitudinal dimension changes only weakly¹. Using two orthogonal probe beams we have access to the column density of the atom gas both in the longitudinal and transverse directions (Fig. 1).

Quantized vortices

One of the most spectacular manifestations of the existence of a macroscopic wave function describing a Bose-Einstein condensate is the nucleation of quantized vortices when the system is set into rotation [6,7]. To understand why these vortices emerge, we write the condensate wave-function as $\psi(\mathbf{r}) = \sqrt{\rho(\mathbf{r})} e^{i\theta(\mathbf{r})}$. The quantity $\rho(\mathbf{r}) = |\psi(\mathbf{r})|^2$ is the particle density in the condensate and the phase θ is defined everywhere that the density is non zero. The “conservation of probability” yields the following relationship between the phase and the macroscopic velocity field \mathbf{v}

$$\mathbf{v} = \frac{\hbar}{m} \nabla \theta. \quad (2)$$

This equation leads to a paradox when one tries to predict the behaviour of a superfluid that is set into rotation at an angular velocity Ω_0 , for instance when the fluid is kept in a rotating bucket. In the case of a classical fluid, the viscous drag between the walls of the vessel and the fluid generates a velocity field analogous to the one of a rotating solid, that is $\mathbf{v} = \Omega_0 \times \mathbf{r}$. The vorticity $\boldsymbol{\Omega} = \text{curl}(\mathbf{v})/2$ is uniform and equal to Ω_0 . A well known effect of this rotation is the characteristic parabolic shape of the free surface of the liquid. However, this scenario is incompatible with equation (2) that yields a curl free velocity field. Therefore, one could expect naively that a

rotating bucket experiment performed on a superfluid should leave its free surface undisturbed. This prediction is however contradictory with experimental observations that show without any doubt that the free surface of a superfluid held in a fast rotating vessel is close to a parabola!

This non-intuitive result was explained by Onsager and Feynman, who showed that equation (2) allows the vorticity to enter a Bose-Einstein condensate along phase singularity lines. Noting that the phase of a wave function is defined within 2π only, equation (2) implies that the circulation of the velocity field along a closed contour must be quantified in units of h/m , that is

$$\Gamma = \oint \mathbf{v} \cdot d\mathbf{l} = p \frac{h}{m}. \quad (3)$$

p is an integer number called the *topological charge* of the flow, and it corresponds to the winding number of the phase along the contour. In order to get a non-zero circulation, it is necessary that the contour winds around a line of zero density, along which the phase, and hence the velocity field, is no longer defined. Otherwise, Stokes theorem implies the cancellation of Γ . These zero density lines carry the vorticity of the flow and are called *quantized vortices*.

The nucleation of such quantized vortices is an experimental proof of the existence of the macroscopic wave function characterizing a Bose-Einstein condensate. Their observation was quite difficult in the case of superfluid liquid helium due to the smallness of the size of the vortex core. As shown by L. Pitaevskii in 1961, this size is of the order of the so called *healing length*

$$\xi = \frac{\hbar}{mc} \quad (4)$$

where c is the sound velocity in the fluid. In the case of helium 4, this length is of the order of a few angstroms. Vortices were observed in this system by Packard and his group in 1979. They were visualized by means of electrons trapped in the vortex cores and accelerated on a phosphorescent screen. By contrast the quantization of the circulation was demonstrated as soon as 1958 by Vinen, who studied the vibration modes of a quartz wire immersed in rotating superfluid helium. Let us also mention the experiment performed in 1985 by Avenel and Varoquaux, which proved the 2π phase slip between two superfluid helium buckets coupled by a capillary tube, when a vortex crosses the tube.

¹ This inversion of the ellipticity is a consequence of the repulsive interactions between rubidium atoms. The transverse directions being the most compressed explode faster when the trap is switched off.

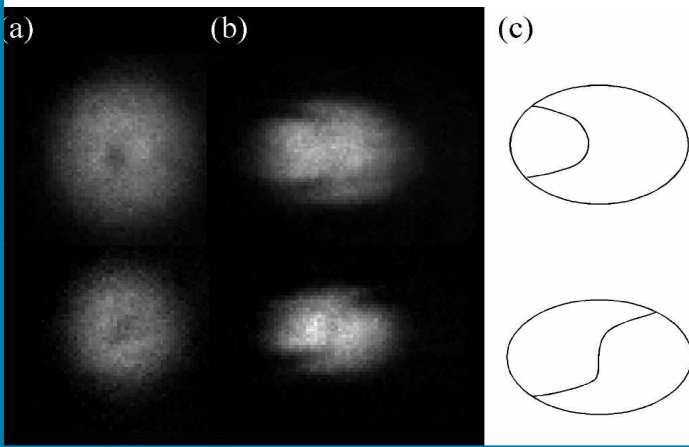

▲ **Fig. 3:** Density profile of the vortex line. a) Longitudinal imaging. The vortex core is identified by the density dip at the center of the cloud. b) Transverse imaging. The vortex line (darker line in the density profile) is bent, which explains the contrast reduction in longitudinal imaging. c) Sketch of images b).

A spoon for an atomic gas

In the case of a gaseous Bose-Einstein condensate, the sound velocity is of the order of a few cm/s (to be compared with hundreds of m/s in helium), yielding a healing length in the micrometer range. The vortices are then directly detectable by optical means and were actively sought as soon as the first alkali Bose-Einstein condensates were obtained. Two strategies have been developed. The first one is based on a direct imprinting of the 2π phase shift on the macroscopic wave function and was successfully implemented by the group of E. Cornell in Boulder [8]. The second method that we developed in Laboratoire Kastler Brossel, in collaboration with V. Bretin, K.W. Madison, P. Rosenbusch and S. Stock [9] is an adaptation of the rotating bucket experiment to a gas of trapped bosons. We confine the atoms in the magnetic trap described above, and we superimpose in the transverse plane an anisotropic potential created by two laser beams propagating along the axis of the trap (Fig. 2). The axes of the anisotropic potential rotate at an angular velocity Ω_0 , and this potential acts like a spoon in a cup of coffee. This stirring

method has been used later at MIT (W. Ketterle's group [10]), Oxford (C. Foot's group [11]) and Boulder (E. Cornell's group [12]).

Above a certain critical angular velocity of the spoon, a first vortex is nucleated and is detected as a depression in the density profile (Fig. 3). The contrast of the density dip is however not 100%. This can be understood when looking at the transverse density profiles which clearly reveal that the vortex line is bent. This bending is a spontaneous symmetry breaking of the system; it originates from the atom interactions, which introduce a non-linear term in the Schrödinger equation satisfied by the macroscopic wave function $\psi(\mathbf{r})$.

Vortex lattices and semi-classical approximation

When one increases the rotation frequency above the threshold for the appearance of the first vortex, new vortices enter the condensate and form a regular lattice known as the Abrikosov lattice in the physics of superconductors (see figure 4). The equilibrium shape of this lattice results from the competition between trapping and Magnus forces. The role of the trapping force is to attract the vortices to the center of the magnetic trap (see for example figure 3 for the case of a single vortex). The Magnus force, which is well known in classical hydrodynamics, induces a repulsion between two co-rotating vortices.

When the number of vortices is large compared to unity, the parameters of the vortex lattice can be deduced from the correspondence principle, as first explained by Feynman. The vortices arrange themselves to form a lattice with a uniform surface density n_v , so that the coarse-grain average of the velocity field mimics the rigid body rotation for an angular frequency Ω . More precisely, although the local velocity field remains highly singular at the core of a vortex, the average velocity field has a uniform vorticity equal to 2Ω . Since each vortex corresponds to a single quantum of circulation h/m , one can deduce the relation between Ω and n_v :

$$2\Omega = \frac{h}{m} n_v \quad (5)$$

This relation is nicely confirmed by experimental observations.

In the regime where many vortices are present inside the trapped condensate, the analogue of the parabolic profile of the free surface of a rotating liquid is the increase of the transverse diameter of the cloud. The centrifugal force reduces the transverse

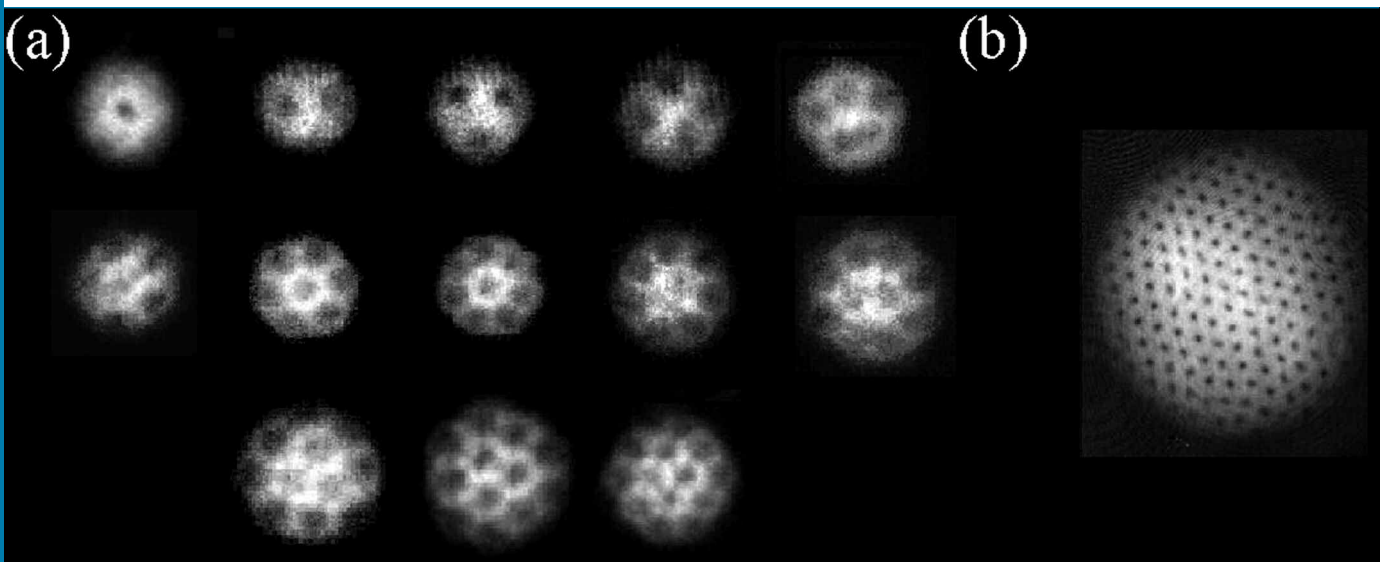

▲ **Fig. 4:** Abrikosov lattice in a fast rotating Bose-Einstein condensate. The formation of this regular triangular pattern is a consequence of the repulsive Magnus force between vortices. a) Vortex lattices (with 1 to 13 vortices) obtained at ENS. b) Giant vortex lattice observed at MIT [10].

confinement of the cloud which occupies a larger volume than when it is at rest.

The regime of fast rotations

When the rotation frequency Ω is increased to a value close to the transverse trapping frequency ω_{\perp} , the transverse size of the condensate tends to infinity since the quadratic confinement potential is nearly balanced by the centrifugal potential, which is also quadratic. The atom density ρ drops down and the healing length (which varies as $\xi \propto \rho^{-1/2}$) can become arbitrarily large. Since the vortex density increases with the rotation speed, there exists a rotation frequency for which the size of a vortex core becomes comparable to the vortex spacing. Above this rotation frequency, the vortex lattice is tightly packed and the size of a vortex core is not anymore related to the healing length. It saturates to a value comparable with the distance between two adjacent vortices, which is of the order of $a_0 = \sqrt{\hbar/(m\omega_{\perp})}$.

In this fast rotation regime, the physics of a rotating Bose-Einstein condensate is very reminiscent of that of a charged particle in a magnetic field. Indeed the transverse force exerted on a single atom located in $\vec{r} = (x, y)$ in the rotating frame is the sum of the trapping, centrifugal and Coriolis terms:

$$\vec{F} = -m\omega_{\perp}^2 \vec{r} + m\Omega^2 \vec{r} + 2m\vec{\Omega} \times \vec{v}.$$

For $\Omega = \omega_{\perp}$, we are left only with the Coriolis term $2m\vec{\Omega} \times \vec{v}$, which is formally equivalent to the Lorentz force exerted by a uniform magnetic field on a charged particle (the cyclotron frequency being equal to $2\omega_{\perp}$). In quantum terms, the energy eigenstates of a particle evolving in a uniform magnetic field are known as Landau levels. The regime of fast rotation, in which the vortex core size saturates to a_0 , corresponds to a situation where interactions and temperature are so low that only the lowest Landau level (LLL) is populated.

The experimental investigation of this fast rotation regime is not an easy task. The stirring method described above fails when $\Omega \simeq \omega_{\perp}$ because of a parametric instability of the center of mass of the gas when it is stirred at a frequency close to the trapping frequency. To circumvent this problem two ways have been explored. At ENS, we have added an extra confinement potential, described by a small quartic term, which eliminates the center of mass instability. We could thus explore the region of fast rotations up to $\Omega = 1.05 \omega_{\perp}$ and investigate the structure of the vortex lattice in this quadratic+quartic potential [13]. The Boulder group has kept a purely harmonic potential and implemented an “evaporative spin up” technique: the atoms with less angular momentum than average are evaporated so that the remaining atoms thermalize at a faster rotation speed. The Boulder group could then reach rotation speeds up to $\Omega \sim 0.99 \omega_{\perp}$ and confirm the predictions made for the size of the vortex core (figure 5 and ref. [14]).

The regime of fast rotation in a harmonically trapped gas is very different from what is expected from an incompressible superfluid in a rigid container, or from what is known for a type II supercon-

ductor placed in a large magnetic field. In the latter case, the regime of overlapping vortices corresponds to a loss of superconductivity, whereas the harmonically trapped Bose gas simply expands over a large transverse area while keeping its coherence properties (at least as long as the number of vortices remains smaller than the number of atoms).

Perspectives

We have presented in this paper only a few illustrations of the fascinating physics of rotating Bose Einstein condensates. The experiments that we did not present include in particular the interferometric detection of the phase slip of the wave function around the vortex core, or the full elucidation of the vortex nucleation mechanism.

Very recently, the group of W. Ketterle (MIT) has observed a vortex lattice in a rotating *fermionic* cloud [15]. This finding might seem surprising at first sight. Indeed, as stated in the beginning of this paper, fermions cannot occupy the same quantum state, hence they should not be able to condense and form a vortex lattice. This paradox is solved by considering the attractive van der Waals interactions existing between atoms. It leads to the formation of pairs of fermions, which can themselves condense in a macroscopic quantum state. This state is very much akin to the many-body quantum state introduced by Bardeen, Cooper and Schrieffer in the 1950’s to explain the superconducting behaviour of electrons in metals at low temperature. The observations of vortices in a cloud of fermions constitute a dramatic demonstration of the coherent nature of this assembly of ultra cold gases of atom pairs.

For the future, one of the most promising perspectives of this field of research deals with the regime of extremely fast rotations, where the number of vortices becomes comparable with the number of atoms. It corresponds to rotation frequencies Ω even larger than those required for reaching the lowest Landau level regime. Several theoretical studies have been performed recently on these systems, but no experimental result is yet available. In this ultra-fast rotation regime, one leaves the domain of simple Bose-Einstein condensation, where all atoms share the same macroscopic wave function. The system is expected to reach a strongly correlated state, similar to those appearing in the description of the fractional quantum Hall effect.

To summarize, the rotations of ultracold bosonic and fermionic gases have already been the subject of several studies, with topics of interest that go much beyond the simple illustration of macroscopic quantum mechanics. In particular it is quite remarkable that the investigation of vortex lattices can now be used as a tool to

► **Fig. 5:** Fractional core area as a function of the LLL parameter. The fractional core area is the ratio of the square of the core size (measured using a Gaussian fit of the density dip at the vortex locations) and the area of the unit cell of the vortex lattice. The LLL parameter is the ratio of the energy splitting between two Landau levels ($2\hbar\omega_{\perp}$) and the interaction energy characterized by the chemical potential μ . The entrance in the LLL occurs for an LLL parameter of order unity. The broken line is the prediction obtained assuming that the vortex core is proportional to the healing length ξ . The dotted line corresponds to the expected limit for the LLL (figure obtained by the group of E. Cornell at Boulder [14]).

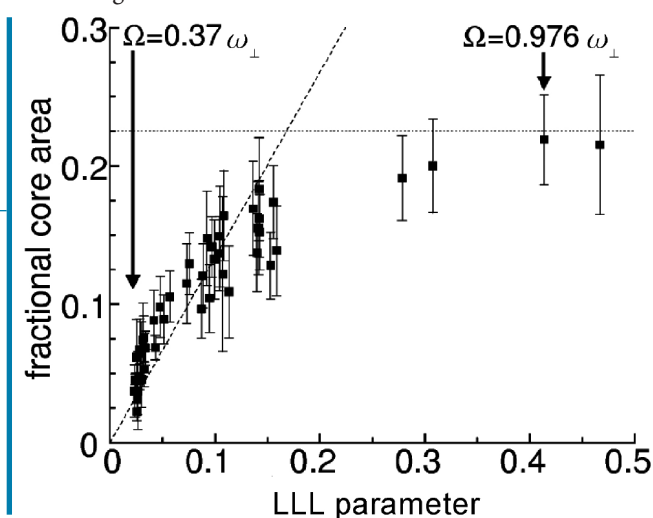

investigate pending outstanding questions of condensed matter physics, either for strongly correlated fermions or bosonic fractional Quantum Hall systems. ■

About the authors

Frédéric Chevy after studying rotating Bose-Einstein condensates during his PhD, spent two years at Collège de France working on surface hydrodynamics of classical fluids. He is now part of the cold atom group at École Normale Supérieure where he works on ultra cold fermions and teaches quantum mechanics and laser physics.

Jean Dalibard has been working in the field of quantum optics and cold atoms since 1982. He is now involved in research on quantum gases and Bose-Einstein condensates. He teaches quantum physics at École Polytechnique and École Normale Supérieure.

References

- [1] M.H. Anderson, J.R. Ensher, M.R. Matthews, C.E. Wieman and E. A. Cornell, *Science* **269**, 198 (1995).
- [2] K.B. Davis, M.O. Mewes, M.R. Andrews, N.J. Van Druten, D.S. Durfee, D.M. Stamper-Kurn et W. Ketterle, *Phys. Rev. Lett.* **75**, 3969 (1995).
- [3] E.A. Cornell et C. Wieman, The Bose-Einstein condensate, Scientific American, March 1998, p. 40.
- [4] C. Pethick and H. Smith, *Bose-Einstein condensation in dilute Bose gases*, Cambridge University Press (Cambridge, England, 2002).
- [5] L. Pitaevskii and S. Stringari, *Bose-Einstein condensation*, Clarendon Press (2003).
- [6] P. Nozières and D. Pines, *The Theory of Quantum Liquids, vol. 1 and vol. 2*, (Redwood City: Addison-Wesley, USA, 1990).
- [7] R.J. Donnelly, *Quantized Vortices in Helium II*, Cambridge University Press (Cambridge, England, 1991).
- [8] M.R. Matthews, B.P. Anderson, P.C. Haljan, D.S. Hall, C.E. Wieman and E.A. Cornell, *Phys. Rev. Lett.* **83**, 2498 (1999).
- [9] K. W. Madison, F. Chevy, W. Wohlleben and J. Dalibard, *Phys. Rev. Lett.* **84**, 806 (2000).
- [10] J.R. Abo-Shaer, C. Raman, J.M. Vogels and W. Ketterle, *Science* **292**, 476 (2001).
- [11] E. Hodby, G. Hechenblaikner, S. A. Hopkins, O. M. Maragò, and C. J. Foot, *Phys. Rev. Lett.* **88**, 010405 (2002).
- [12] P. C. Haljan, I. Coddington, P. Engels, and E. A. Cornell, *Phys. Rev. Lett.* **87**, 210403 (2001).
- [13] V. Bretin, S. Stock, Y. Seurin, and J. Dalibard, *Phys. Rev. Lett.* **92**, 050403 (2004)
- [14] V. Schweikhard, I. Coddington, P. Engels, V. P. Mogendorff, and E. A. Cornell, *Phys. Rev. Lett.* **92**, 040404 (2004).
- [15] M. W. Zwierlein, J. R. Abo-Shaer, A. Schirotzek, C. H. Schunck and W. Ketterle, *Nature* **435**, 1047 (2005).

Blue skies, blue seas

L.J.F.(Jo) Hermans,
Leiden University • The Netherlands

For the sky, it's simple. Most physicists know that the blue colour of the sky is due to the $1/\lambda^4$ dependence of Rayleigh scattering. But what about the blue of the sea? Could it be simply reflection of the blue skies by the water surface? That certainly cannot be the main story: even if the sky is cloudy, clear water from mountain lakes and seas can look distinctly blue. Moreover: those of us who like to dive and explore life under water will have noticed that, a few meters under the surface, bluish colours tend to dominate. Indeed, if we use an underwater camera and take pictures of those colourful fish, we notice that the nice red colours have almost completely disappeared. And – unlike our eyes – cameras don't lie. We need a flash to bring out the beautiful colours of underwater life. In other words: absorption is the key: sunlight loses much of its reddish components if it has to travel through several meters of water. Or ice, for that matter: remember the bluish light from ice caves or tunnels in glaciers. And even the light scattered back from deep holes in fresh snow is primarily blue.

What causes the selective absorption of visible light by water? Spectroscopists know that the fundamental vibrational bands of H-atoms bound to a heavier atom, such as in H_2O , are typically around $3\ \mu\text{m}$. This is way too long to play a role in the visible region. But wait: because of the large dipole moment of H_2O also overtone and combination bands give an appreciable absorption. And they happen to cover part of the visible spectrum, up from about 600 nm, as seen in the figure. The strong rise near 700 nm is due to a combination of symmetric and asymmetric stretch ($3\nu_1 + \nu_3$), slightly red shifted due to hydrogen bonding (see, e.g., C.L. Braun and S.N. Smirnov, *J. Chem. Edu.*, 1993, **70**(8), 612). We notice

that the absorption coefficient in the red is appreciable: it rises to about $1\ \text{m}^{-1}$ around 700 nm, an attenuation of a factor of e at 1 m. It is no wonder that our underwater pictures turn out so bluish.

It is interesting to note: the spectrum of D_2O is red shifted by about a factor 1.4, since the larger mass of the deuterons makes for much more slow vibrations. It is therefore shifted out of the visible region.

But that is not the whole story about the 'deep blue sea'. For the water to look blue from above, we need backscattering. For shallow water, this may be from a sand bottom or from white rock. In this case the absorption length is twice the depth. For an infinitely deep ocean, however, we have to rely on scattering by the water itself and by possible contaminants. This even enhances the blue color by Rayleigh scattering, as long as the contaminants are small. If the water gets really dirty, things obviously become more complex. Scattering from green algae and other suspended matter may shift the spectrum towards green, or even brown.

But clear water is blue. Unless it's heavy water, of course... ■

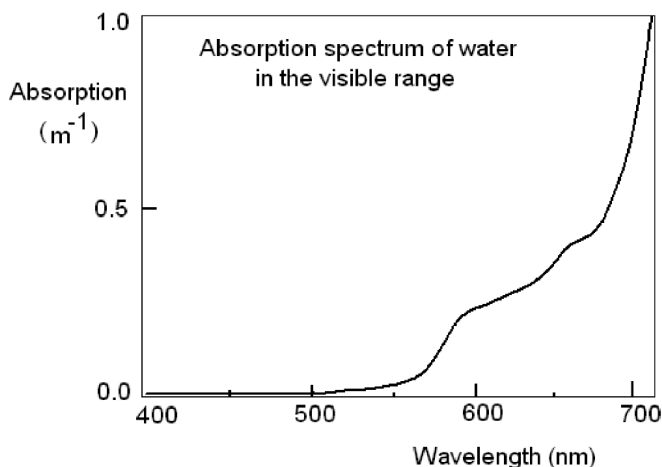

The rainbow

Owen Davies, Jeff Wannell, and John Inglesfield,
School of Physics and Astronomy, Cardiff University, 5 The Parade, Cardiff • CF24 3YB • UK.

The rainbow, with its arc spanning the sky, is a glorious sight which never ceases to amaze. Rainbows have always been a source of wonder [1], sometimes as a symbol of the gods, sometimes as an evil omen, and have inspired artists (who often get it wrong) and poets such as the Lakes poet, Wordsworth [2]:

“My heart leaps up when I behold
A rainbow in the sky...”

For physicists, part of the wonder of rainbows is the way that they literally illustrate so many aspects of the nature of light: most obviously, breaking up white light into the spectrum of colours. They also combine ray aspects of light, determining the angular size of the primary and secondary rainbows, and the wave nature of light which produces weak “supernumerary” bows, often visible inside the main primary. Some of the properties which we shall discuss in this article are apparent in the rainbow shown figure 1, in which we can just see the weaker secondary, some supernumeraries, and the property that the sky is light inside the rainbow and dark outside.

Rays of light

We all know of Newton’s experiment with a prism, breaking up a beam of light into the spectrum of colours, and indeed it was Newton who explained the way that the wavelength-dependence of the refractive index of the raindrop produces the colours of the rainbow. But what is startling about the rainbow is the sheer intensity of the spectrum, a result of the way that the raindrop concentrates the different colours in different directions. And to understand this we must go back to Descartes [1], who in 1637 described the paths of rays of light through the raindrop, using the sine law for refraction which we know today as Snell’s law. (It is not clear whether Descartes knew of the work of Snell; Newton incorrectly credited de Dominis with the explanation of the rainbow, and was rather casual about Descartes’ real explanation [1].)

Rays of light are refracted as they enter the drop, and are then reflected inside the drop at the air-water interface – once in the formation of the intense primary rainbow, twice for the much weaker secondary bow – and refracted a second time as they leave the drop (figure 2). Further reflections are possible, but as we shall see, higher order rainbows are rather theoretical. Concentrating on the single reflection, figure 3 shows the paths of different rays incident on the drop: ray 1, incident towards the centre of the drop, is reflected back along its own path, but rays hitting higher up the drop are reflected with increasing angles between the incident and reflected rays. This continues up to a maximum angle of about 42° reached by ray 7, determined by simple geometry from the refractive index of water. Beyond this ray, appropriately called the Descartes ray, the angle decreases. We have a maximum – the rays near the Descartes ray emerge in almost the same direction – and the raindrop scatters most light at an angle of 42° to the incident light. Taking into account the variation of the refractive index n with wavelength – the dispersion – gives a rainbow angle of 42.2° for red light with $n = 1.332$ and 40.6° for violet with $n = 1.343$ (the refractive indices are taken from a very useful web site, [4]). For two reflections (figure 2), we have a minimum angle between the incident and scattered ray giving the secondary bow with an angular size of about 51° . Because the rays of light bend round on themselves, as we see from figure 2, red is on the inside of the secondary rainbow, with violet on the outside.

From this geometry, the primary and secondary bows appear as arcs making angles of 42° and 51° around the extension of a line from the sun and passing through the observer’s head (figure 4). As a consequence, when the sun is high in the sky the rainbow may appear against the ground. All rainbows have the same angular size, whether they are due to a shower several miles away, or the spray from the garden hose above the lawn. We may ask where we see the rainbow – do we see it at the drops, perhaps? From figure 3 it seems that our eyes focus the rays contributing to the rainbow at infinity, and the rainbow has only a direction rather than a position. There is another point of view (literally), which also suggests that if the rainbow has a location, this is at infinity – if we, as observers, move, the rainbow moves with us. This means that a stereoscopic view of the rainbow, with our two eyes, or the rangefinder of an old-fashioned camera, will place the rainbow at infinity [1].

The ray theory of the rainbow can be neatly represented as polar plots of the scattered intensity in different directions after one, two, or more reflections. To calculate these, we combine Fresnel’s formulae for the intensity of reflected and transmitted light [5] with simple ray geometry for different angles of scattering. We obtain the results shown in figure 5 for the scattered intensity for the two polarizations of light. In these figures, we have light coming horizontally from the left-hand side, incident on a raindrop at the centre; the left-hand diagram corresponds to light polarized with its electric field perpendicular to the plane of the diagram (*s*-polarisation), and on the right the electric field is in the plane (*p*-polarisation). The large lobe to the right of the drop in both figures represents light passing through the drop, refracted but without any reflection. The primary bow corresponds to the singularity in the scattering after one reflection at $\pm 42^\circ$ with respect to the incident light, showing up very strongly in *s*-polarisation, but much weaker in *p*-polarisation: the rainbow is *strongly polarised*. The figure shows very clearly how light undergoing one reflection

▼ **Fig. 1:** Rainbow above the Lake District fells: the much weaker secondary bow is just visible, with reversed colours. Several supernumerary bows, with alternating green and violet, can be seen inside the brilliant primary. The sky is distinctly darker outside the primary.



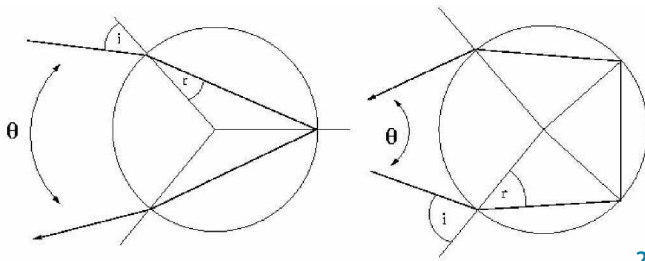

2

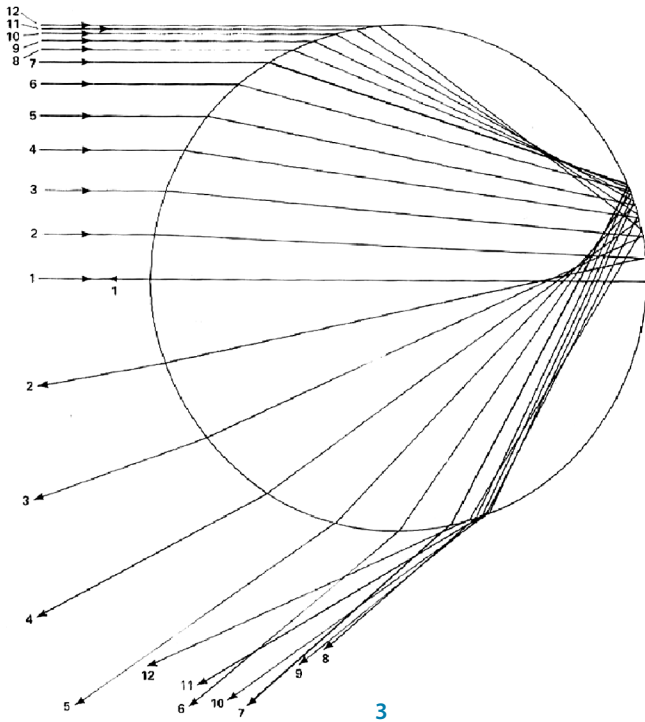

3

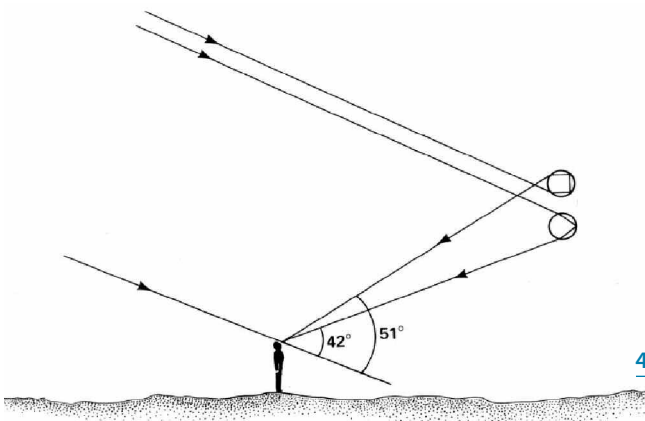

4

▲ **Fig. 2:** Rays of sunlight refracted and reflected inside a raindrop: the left-hand figure, with one reflection, shows the paths which lead to the primary, and the right-hand figure, with two reflections, the secondary.

▲ **Fig. 3:** Parallel rays of light incident on the raindrop, with one reflection. Ray 7, the Descartes ray, emerges at the greatest angle, and rays pile up in this direction. (Figure from [3].)

▲ **Fig. 4:** Drops at an angle of 42° to the line from the sun, passing through the observer's head, scatter sunlight to form the primary bow. Those drops at an angle of 51° scatter sunlight to give the secondary. The diagram should be rotated about this line to form the complete bows. (Figure from [3].)

is back-scattered up to this maximum angle, and beyond $\pm 42^\circ$ no light is scattered. At $\pm 51^\circ$ there is a singularity for scattering after two reflections – the secondary bow – again strongly polarised. This singularity is the opposite way round from the primary bow singularity, with two reflections scattering some light beyond $\pm 51^\circ$, though this does not show up on the scale of the plots.

These singularities in the scattering intensity I as a function of angle ϑ have the form $I \propto |\vartheta - \vartheta_0|^{-1/2}$, where ϑ_0 is the rainbow angle [7]. To derive this we must be clear what we mean by I – as usual in treating scattering, $I(\vartheta)d\vartheta$ is the intensity of light scattered into a small range of angles $d\vartheta$ (this is strictly speaking in two dimensions, and in three dimensions there is an extra factor of $\sin\vartheta$). It follows that together with the various reflection and transmission coefficients, I contains the term $|dy/d\vartheta|$, where y is the “impact parameter” of the ray of light incident on the raindrop, the height above ray 1 in figure 3. As $\vartheta(y)$ is parabolic at the maximum corresponding to the Descartes ray, $|dy/d\vartheta|$ varies like $|\vartheta - \vartheta_0|^{-1/2}$, hence the singularity in the scattering. Except for the primary rainbow in s-polarisation, the singularity is too narrow to be apparent in figure 5. We shall see shortly what happens to this singularity when the wave nature of light is considered.

The light scattered up to $\pm 42^\circ$ produces a bright sky inside the primary, the brightness increasing as the rainbow is approached. This can be seen quite clearly in figure 1. As no light is scattered for one or two reflections between $\pm 42^\circ$ and $\pm 51^\circ$, the sky appears dark in this range of angles – this phenomenon goes under the name Alexander's band, perhaps reminiscent of some dance band from the 1920's, but in fact named for the Greek philosopher Alexander of Aphrodisias (the names get more and more unlikely) [1]. Are there higher order rainbows, corresponding to three, four and more reflections? From figure 5 we see that three reflections produce weak singularities at $\pm 42^\circ$ in the forward direction (for $n = 1.332$), and though it is not clear, four reflections produce still weaker singularities at $\pm 43^\circ$, almost on top of the three reflections peak. In principle these correspond to higher order rainbows around the sun, but the fact that the singularities are extremely weak and lie inside the large forward scattering lobe means that they must be practically invisible. Bernoulli thought that the sharp-eyed lynx or eagle might discern these higher order bows [1] – alas, it seems very unlikely [3]. Quite frequently we have been told about “rainbows” visible around the sun – these are invariably ice crystal halos, and on such occasions we refer our friends to Greenler's “Rainbows, Halos, and Glories” [3]. Very higher order bows can in fact be measured in laser experiments [6].

Close to the singularity, the scattering in the primary bow is 96% s-polarised, and in the secondary 90%. This polarisation results from the fact that the angle at which the light is reflected inside the drops is close to the Brewster angle, at which the reflection coefficient for p-polarised light is zero [5]. Taking the refractive index for water for green light as $n = 1.335$, the Brewster angle is 37° , and the angle of reflection of the Descartes ray for the primary bow is 40° . At this angle the ratio of the p to s reflectivities is 0.03. For the secondary bow the angle of reflection is 45° , giving a ratio of the reflectivities of 0.26 at each of the two reflections. The s-polarisation of the rainbow corresponds to the electric field vector being tangential to the bow, and consequently it is interesting to view the bow through Polaroid. The segment of the rainbow which is tangential to the plane of polarisation of the Polaroid appears relatively brighter compared with the background sky, quite a striking effect [8].

The scattering intensity for single reflection in p-polarisation displays a curious angular variation within the primary rainbow singularity (figure 5). This is a consequence of the fact for a range

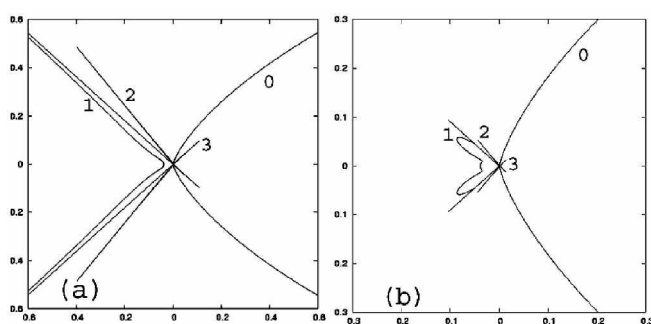

▲ **Fig. 5:** Polar diagram of scattering of light incident horizontally from the left on a raindrop at the centre of the figures. (a) *s*-polarisation (electric field perpendicular to plane of figure); (b) *p*-polarisation (electric field in plane). The numbers indicate the number of reflections. The refractive index is taken as $n = 1.332$ (corresponding to red light).

of angles inside the rainbow angle, there are two rays which contribute to the intensity at each ϑ ($15^\circ < \vartheta < 42^\circ$), each with its variation in reflectivity as the Brewster angle is approached. We doubt whether this scattering has been seen, as these lobes are very weak compared with the *s*-polarisation rainbow. We should note here that a scattering angle of 15° , the minimum angle for which two rays contribute, corresponds to the incident ray which grazes the raindrop, the only ray for which total internal reflection occurs.

Wave-fronts and waves

Rainbows produced by raindrops about 1mm in diameter or smaller often show several extra bands of colour, typically alternating green and violet [8], inside the primary (figure 6) – these are the supernumerary bows, produced by interference of the light waves [3]. The two rays which leave the drop for a range of directions inside the rainbow angle have different path-lengths, and interfere with one another. To obtain quantitative results, we first construct the geometrical wave-front, a surface perpendicular to the classical rays, on which the phase of the waves is constant. In the Huygens-Fresnel semi-classical approach, each point on the wave-front is considered as a source of spherical waves, which interfere with each other – this is not a full solution of the wave equations, but is a good approximation when the wavelength is small compared with the dimensions of the object scattering the light [5].

Geometrical wave-fronts corresponding to light leaving the raindrop are shown in figure 7, the different curves corresponding to different phases of the waves, or different path-lengths the waves travel. The fronts which intersect the drop are, in fact, *virtual*, formed by extending the actual wave-fronts backwards through air rather than through the drop. They correspond to the rays leaving the drop extended backwards as straight lines. What we immediately notice are the cusps in the wave-fronts, which lie on the Descartes ray (except close to the drop), and trace out a caustic. (The bright patterns on the surface of the breakfast cup of tea reflected from the kitchen spotlight are a familiar example of caustics.) It is the interference between the wave-fronts on either side of the cusps which give rise to the supernumeraries.

The next step is to use one of the wave-fronts as a source of waves, to find the intensity as a function of scattering angle. This calculation was first performed by Airy, described in a classic paper

▶ **Fig. 6:** Rainbow above Penyghent, North Yorkshire, with several supernumerary bows inside the primary. The secondary bow is barely visible.

published in 1838 [9], following Young's realization in 1804 that interference causes the supernumeraries [10]. A wave-front which we may use is the right-hand one in figure 7 and we use the axes shown on the diagram, with the *y*-axis in the direction of the Descartes ray. Then the Fresnel formula tells us that the amplitude of the diffracted ray at a large distance from the drop, at angle ϑ to the Descartes ray, is proportional to the integral along the wave-front, $\int \psi \exp[i2\pi(x\sin\vartheta + y(x)\cos\vartheta)/\lambda] \sqrt{1+(dy/dx)^2} dx$. Here, λ is the wavelength of the light, and ψ is the amplitude of the electromagnetic field over the wave-front, whose equation is $y(x)$ [5]. The exponential gives the phase of the contribution over the wave-front, and the square root gives the length of the element of the wave-front; positive ϑ corresponds to scattering outside the Descartes ray. Why do we choose this particular wave-front for the Fresnel integral? We want to avoid the singularity of the later wave-fronts with cusps, and the wave-front where the cusp just finishes has a large amplitude right at the end, a point through which many classical rays pass. Moreover, this virtual wave-front has a simple analytic form in the region which mainly contributes to the integral, $y \approx \alpha x^3$ – a result which Airy used to evaluate the integral in terms of his famous function.

In evaluating the diffraction integral, Airy assumed that the amplitude ψ was constant over the wave-front; neglecting the square root for the length of wave-front, the diffraction amplitude for small angle ϑ is given by the Airy integral

$$\Psi(\vartheta) \propto \int_0^{\infty} \cos[2\pi(x\vartheta + \alpha x^3)/\lambda] dx.$$

This may be expressed in terms of the Airy function Ai , $\Psi(\vartheta) \propto \text{Ai}(\vartheta/y)$, with $y = (3\alpha[\frac{\lambda}{2\pi}]^2)^{1/3}$ – Airy evaluated his function by hand, but it is now immediately available in computer packages. The cubic coefficient α depends on the refractive index, and for $n = 1.335$ it is given by $\alpha = 1.62/R^3$, where R is the radius of the raindrop [11]. The resulting diffraction intensity is shown in figure 8, for light of wavelength $\lambda = 500$ nm scattered by a drop of radius 0.5 mm, plotted as a function of angle from the Descartes ray. We see that the singularity in ray theory is replaced by a finite peak, the primary bow in diffraction theory, with a maximum at about $1/4^\circ$ inside the Descartes ray. The subsequent peaks constitute the supernumerary bows.

The integrand in the Airy integral oscillates very rapidly as x varies over the wave-front, when angle ϑ is negative, except where the wave-front is perpendicular to the direction in which the amplitude is evaluated. For a range of angles inside the Descartes ray there are two points at which the wave-front is perpendicular, corresponding to two classical rays travelling in this direction. Rays AA' and BB' in figure 7 are two such rays, travelling at $\vartheta \approx -5^\circ$ from the Descartes ray, and at the points of intersection with the wave-front a' and b' the front is perpendicular. Around these two points,



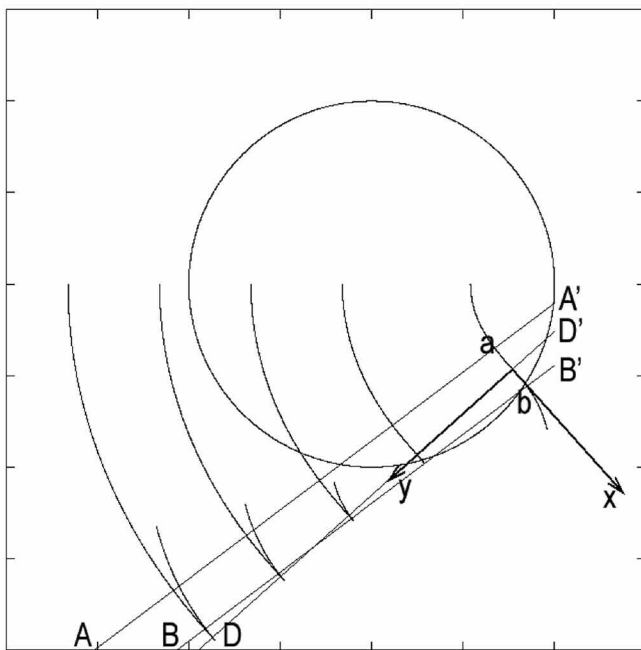

◀ **Fig. 7:** Wave-fronts of rays leaving the raindrop, $n = 1.335$, with rays incident on the drop as in figure 3. The wave-fronts intersecting the drop are “virtual”, extended backwards through air. DD’ is the Descartes ray leaving the drop, and AA’, BB’ are the two rays leaving the drop at a scattering angle inside the rainbow angle, which can interfere. All these rays are extended backwards through air. Local axes x and y are for the Fresnel integration over the wave-front.

the phase in the cosine integrand varies very little, and this dominates the integral. The method of stationary phase shows how the integral may be determined in terms of the contributions from these two regions [12], and the result is that the amplitude is given approximately by $\Psi(\vartheta) \approx \cos[\pi/4 - \frac{2}{3}(|\vartheta|/y)^{3/2}]/[\sqrt{\pi}(|\vartheta|/y)^{1/4}]$, ϑ

negative. The corresponding intensity is shown by the dark blue line in figure 8, and we see that apart from a very small range of angles as we approach the Descartes ray, this approximation is amazingly accurate. The method of stationary phase gives the interference pattern from the two rays travelling in direction ϑ , producing supernumeraries. Something surprising, which does not come out of a straightforward interference picture, is the phase shift of $\pi/4$ found in the stationary phase result given above, shifting the first maximum and the supernumeraries. Such phase shifts, and the general study of wave forms near ray caustics and singularities, are a very active topic of current research, and there are many papers by Berry and co-workers in this area [10].

For positive angles, the method of steepest descents [12] may be used to obtain an approximation to the Airy integral (this method is the same as stationary phase if we go into the complex plane), giving $\Psi(\vartheta) \approx \exp[-\frac{2}{3}(\vartheta/y)^{3/2}]/[2\sqrt{\pi}(|\vartheta|/y)^{1/4}]$, ϑ positive.

This gives the intensity shown by the green line in figure 8, again remarkably accurate beyond $\vartheta \approx +1/4^\circ$. The Airy function crops up

▼ **Fig. 8:** Intensity of light, wavelength 500 nm, scattered by a raindrop of radius 0.5 mm. Angles are measured from the Descartes ray. Red line: Airy theory; blue line, stationary phase approximation for negative angles; green line, steepest descents approximation for positive angles.

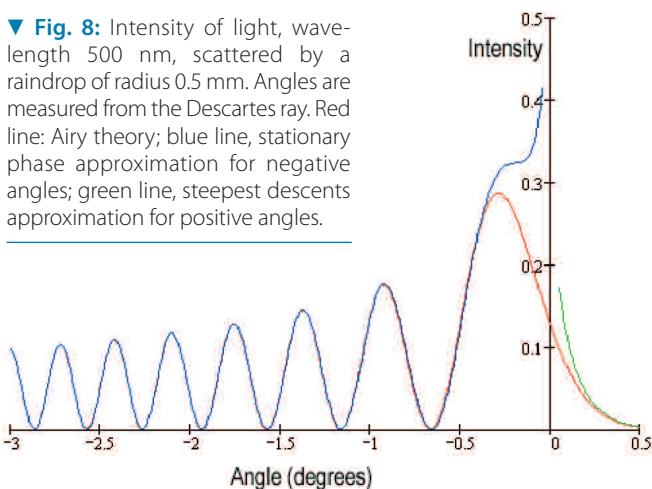

again and again in physics, in particular as the solution of the Schrödinger equation in a linear potential, and these approximate expressions for the Airy function (actually the first terms in an asymptotic expansion) are important in the mathematical analysis of this equation [12].

From supernumeraries to fog-bows

It is remarkable that interference fringes show up as supernumeraries in the rainbow, when we consider that the light waves are being scattered by raindrops 1000 times larger – we are used to interference effects in scattering over length scales comparable with the wave-length of light. Supernumeraries are even more remarkable when we consider that this effect of light waves appears in a large-scale phenomenon, traversing the sky! The appearance of these supernumeraries depends on the size of the raindrops scattering the light, and we can explore this using the theory described above.

The intensity of light scattered by the raindrop at varying angles in the primary bow is shown in figures 9a and 9b, for raindrops of radius 0.3 mm and 0.05 mm respectively. On each figure, the three curves correspond to red, green and blue light. For raindrops of radius 0.3 mm (figure 9a) we see that red and green give good strong principal peaks, with the first supernumerary of red overlapping with the first peak of blue – these constitute the primary bow, with the overlapping red and blue enhancing the violet. Inside the primary we see supernumeraries, which are initially alternating green and red + blue. It is a little dangerous to go from this figure directly to the actual appearance of the rainbow; for this we should consider the scattering of the whole spectrum of visible light, and then use the trichromatic nature of colour vision to work out the appearance of the rainbow [1]. But figure 9a, taken at face value, is consistent with the supernumeraries described by Minnaert in his classic book [8], as alternating “violet-pink” and green (the violet-pink comes from the superposition of the red and blue peaks). We can make out several supernumeraries just inside the primary bow in figure 6, and at least on the original photograph these are seen to be alternating violet and green. In nature, only a few supernumeraries are ever visible – for one thing, raindrops are unlikely to have a uniform size, and this varies the phase and wavelength of the oscillations. Moreover, the sun has an angular diameter of about $1/2^\circ$, again smearing out the supernumeraries. The supernumeraries will be less apparent with bigger drops, for which they are more closely spaced, and hence more likely to be lost.

With very small drops of radius 0.05mm, mist rather than rain, the principal peaks broaden and overlap completely (figure 9b). The colours of the primary bow are completely smeared out – we observe in this case a white rainbow, or fog-bow, the figure suggesting that the supernumeraries should be quite strong. Some photographs in the literature [1] and on the web do show supernumeraries with fog-bows, but the only time that one of us observed a complete white rainbow, only the principal bow was visible, and this rather faint (figure 10). As there is no mist or fog (the visibility of the snow-covered Helvellyn ridge is excellent), this must be a cloud-bow, formed by droplets in the clouds.

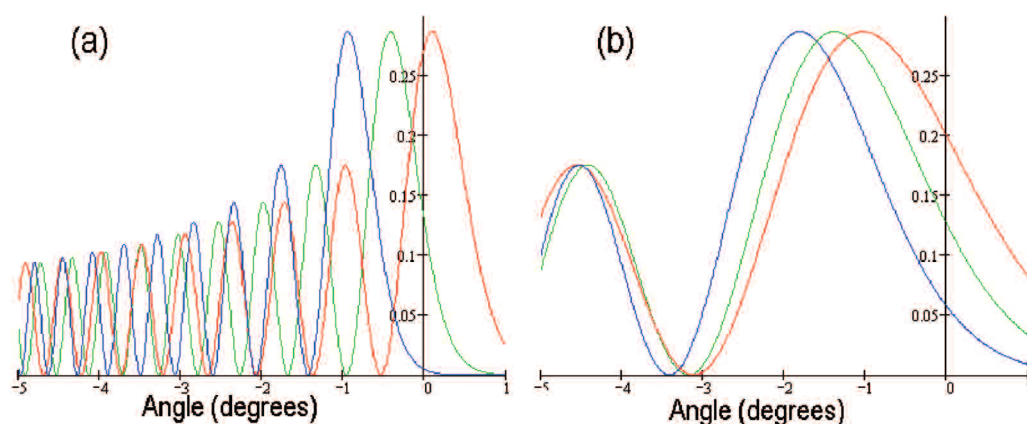

◀ **Fig. 9:** Intensity of light scattered by raindrops of (a) radius 0.3 mm and (b) 0.05 mm. The different curves correspond to red, green and blue light, and angles are measured from the Descartes ray for green light.

Beyond the rainbow

The theory of the rainbow which we have described explains everything in terms of classical rays of light, even Airy theory boiling down to interference between two rays of light travelling in the same direction. However, these theories are not the whole story of light scattering by water droplets, and they cannot begin to explain another phenomenon involving light scattering from mist – the glory, and the Brocken spectre [3,8]. The full scattering theory of light by a dielectric sphere – Mie theory – is needed to understand the glory, and computer programs are available on the web to explore this [4]. The beauty of the physics of rainbows is that so much can be understood in terms of rays and simple wave theory: rainbows open our eyes to some of the fundamental properties of light. ■

Acknowledgements

The photographs in this article were taken by Whin Inglesfield, to whom we are very grateful.

About the authors

Owen Davies and Jeff Wannell both obtained the MPhys Degree in Cardiff in 2001, and this article is based on their final year project dissertation, supervised by John Inglesfield. Jeff has since become a banker. Owen obtained a PhD in Cardiff in 2005, on the theory of DNA, and now works in the City of London.

John Inglesfield received his PhD in 1970 from Cambridge, and is a professor of physics in Cardiff. His research interests are the theory of surface electronic structure, and most recently DNA and photonics.

References

- [1] R.L. Lee, Jr. and A.B. Fraser, *The Rainbow Bridge: Rainbows in Art, Myth, and Science* (Pennsylvania State University Press, University Park, PA) (2001).
- [2] W. Wordsworth, “*My heart leaps up*” (March 1802).
- [3] R. Greenler, *Rainbows, Halos, and Glories* (Cambridge University Press) (1980), now available from www.blueskyassociates.com/books.html.
- [4] www.philiplaven.com
- [5] M. Born and E. Wolf, *Principles of Optics* (Cambridge University Press) (1999).
- [6] Jearl D. Walker, *Am. J. Phys.* **44**, 421 (1976).
- [7] M.V. Berry and S. Klein, *Eur. J. Phys.* **18**, 303 (1997).
- [8] M.G.J. Minnaert, *Light and Color in the Outdoors* (Springer-Verlag, Berlin) (1993).
- [9] G.B. Airy, *Trans. Camb. Phil. Soc.* **6**, 379 (1838).
- [10] M.V. Berry, *Phil. Trans. Roy. Soc. Lond. A* **360**, 1023 (2002).
- [11] H.C. van de Hulst, *Light Scattering by Small Particles* (John Wiley, New York) (1957).
- [12] H. Jeffreys and B.S. Jeffreys, *Methods of Mathematical Physics* (Cambridge University Press) (1972).

▼ **Fig. 10:** Cloud-bow on a winter's day above the Grasmere fells, Lake District. As an aid to the eye (the bow is faint), it appears as an almost complete semicircle, spanning the double photograph.



Metrology: time for a new look at the physics of traceable measurement?

L.R. Pendrill,

SP Swedish National Testing & Research Institute, Measurement Technology, Box 857 • S-501 15 BORÅS • Sweden

How do advances in physics contribute to the international system of measurement units, the SI, and to better measurements in all parts of society? Can collaboration between academic physicists and the national metrology institutes be more co-ordinated than today's occasionally ad hoc in order to better meet future demands for traceability?

The International System of Units referred to as the SI, covering the base units (metre, kilogram, second, kelvin, candela, ampere, mole) and the derived units, provides a basis for ensuring that reliable measurements give the same answer wherever they are made in modern society. This system is based on and, in turn, supports continual and long-term research in fundamental science and technology. There are many and distinguished examples where fundamental physics has contributed to the development of the SI and traceable measurements, involving several Nobel prizes in Physics.

There are ever increasing demands for traceable measurement – enabling reliable measurements that give the same answer wherever they are made - not only in traditional areas such as manufacturing and process industries but increasingly in wider areas:

- The emergence of new areas of science and technology such as nanotechnology and biotechnology
- The need to support traditional areas of physical metrology in which research is often becoming more complex
- Increased recognition of the value of Metrology in existing areas (clinical medicine, food safety, the environment etc)

In fact, demands are increasing so much that primary metrology, as provided by the national metrology institutes, is facing a dilemma of increasing consequence, since resources are limited. To solve this dilemma, European metrologists and others with a vested interest in traceable measurement are at present formulating plans for a new European-wide coordination of national metrology research programmes. In particular, a European ERA-NET programme iMERA [1], with the support of the European Commission, “*Implementing Metrology in the European research Area*”, is at present laying the foundations of a co-ordinated approach to meet these metrology needs in Europe. The most recent plans for the EU's 7th framework programme in fact mentions metrology as one of only four proposed candidates for an Article 169 coordination action.

Primary standard of length – SI metre - a dynamic evolution

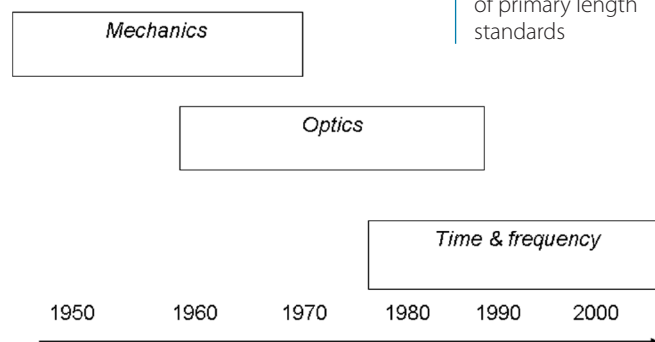

◀ Fig. 1: The dynamic evolution of primary length standards

The European metrology infrastructure is underpinned by the National Metrology Institutes (NMIs) in Europe. The NMIs provide the primary measurement capability to the calibration community and to industrial, regulatory and scientific customers. To ensure that this capability remains at the cutting edge many of the NMIs undertake significant research and development (R&D). This leading edge capability in turn provides the tools that enable world class R&D in wider fields.

Physics and the SI

Accurate measurement:

Is it the domain of the Engineer or the Physicist?

“The number of electrical measuring instruments recently devised is very great. The practical man is not satisfied with the delicate instruments of the physicist, whilst the latter, of course, cannot be satisfied with the results of the measuring instruments arranged by engineers and technical electricians, however satisfactory for industrial purposes” (*The Telegraphic Journal* 1884, quoted in [2])

Measurement accuracy is an elusive concept, often with different meanings for different people as illustrated by the above quote from over 120 years ago.

A good description may be found in recent international standardisation where accuracy is defined in terms of both precision (amount of scatter in repeated measurement data) and trueness (size of systematic error).

A broad generalisation would be to assign the task of achieving good precision to the measurement engineer, whereas it is the task of the physicist to provide best estimates of the true value of a physical quantity. Here “truth” refers not simply to a freedom from error, but to something rather more absolute, as we discuss below.

Absolute accuracy and physics

The “delicate” instruments of the physicist, referred to in 1884, were not only used merely to make precise measurements (such as of the small electric currents in earlier telegraphy). The physicists’ instruments also provided above all an “absolute” accuracy, in other words a “trueness”, by which electrical quantities could be derived from the units of length, mass and time, the fundamental “base” units of the Metric system at that time. The universality and trueness of the latter were based on the ultimate physical reference of the era, namely the size and period of rotation of the Earth in true revolutionary universality “A tous temps: A tous peuples”. It took many years and was not until the electron was discovered at the turn of the century before direct electrical measurements, with the voltmeter and ammeter, became to be raised in dignity and gain recognition as part of fundamental physics [3].

The same holds today in metrology: it is important to make precise measurements, in terms of low scatter or small uncertainty, as may be achieved by engineering a better measurement instrument. But perhaps arguably the main realm of the physicist in metrology is to provide for measurements which are traceable to absolute measures (ultimately, the universal fundamental constants). This enables the results of measurement to be related, not only of a particular quantity made by different people at different times and places (so important for trade and industry) but also to express dif-

Needs	Science/strategic	Manufacturing	Trade	Nano-technology	Regulation	Food
Ressources						
Mass		X		X		X
Lenght		X				
Time	X				X	
Electricity				X		
Amount of substance			X			

ferent – apparently unrelated – quantities to each other in a more global sense. This latter universality of fundamental metrology relies on our understanding of the structure of the universe – spanning the realms of cosmology to elementary particle physics [4].

Examples of the Physics behind the SI

The symbiotic development of metrology and physics can be well illustrated by the development of the SI definition of the unit of length – the metre.

At the end of the 19th century, Michelson in pioneering work at the BIPM performed optical interferometric length measurement, linked the optical wavelength of an atomic discharge lamp to the metre as realised at that time with prototype bars. These bars were a practical realisation of the standard of length based on the circumference of the Earth since the days of the French Revolution. Building in part on Michelson's early research, during the first half of the 20th century, the wavelength of discharge lamps (such as krypton) provided a suitable definition of the metre of the Metric System. With the advent of the laser in the late 1950's (Nobel prize in Physics 1964 [5]), optical interferometric length measurement advanced where the increased coherence of laser light compared with conventional light sources enabled measurement over greater distances and with better accuracy. At the same time this coherence was also exploited in controlling the absolute wavelength of the novel lasers which became a de facto length standard when actively stabilised to a stable spectral reference, such as an atomic or molecular resonance, based on advances in laser spectroscopy (Nobel prize in Physics 1981 [6]). By the time it was judged appropriate to re-define the metre of the SI, the field had advanced sufficiently that the new definition of the metre is now expressed in terms of the distance travelled by light in a certain time interval [7]. This definition implies a fixed value of the speed of light and reflects the higher accuracy of time/frequency measurement compared with interferometric length measurement and, most recently with the technique of optical frequency comb which enables the comparison of optical and microwave frequencies with essentially unlimited accuracy (Nobel prize in Physics 2005 [8]) way beyond the limits set in optical interferometry.

Much of the research lying behind this example of the dynamic evolution of the SI metre, and similar developments for the other measurement quantities (Table 1), has been performed not only at the national metrology institutes but also at many of the leading university and research institutes. Fundamental metrology has benefited from scientific “spin-off”, in some cases in an *ad hoc* manner, in others, in symbiosis, with the development of fundamental physics and applied technological research.

▲ Fig. 2: Matching needs and resources in metrological traceability

Future challenges for accurate and efficient measurement

As a link between fundamental science and the needs of society, metrological traceability forms an essential technological infrastructure for modern society [9].

The continual increase in demand for accurate and efficient measurement in science, technology and international trade lead to the need to develop improved measurement standards and techniques. These developments need to be carried out well in advance of their application in science and industry, and can only take place on the basis of a solid foundation of long-term metrological research closely linked to advances in science

Particular challenges in the development of metrological traceability which can be met by intensified research are [10]:

A. Implementation of measurement systems

- Extended measurement areas and measurement quality
- Extended scales (pico, (10^{-12}) to tera (10^{12}))
- On-line, dynamic measurements
- Several simultaneous parameters

B. Development of measurement systems

- Sensor development
- Fundamental science (nanophysics, microwave photonics, surface chemistry, etc)
- Networking of measurement sensors

C. Measurement knowledge transfer

- Industrial metrology training
- Industrial measurement needs and applications
- University measurement education
- Mobility of national metrologists

The spectacular development of novel sensors, based on many principles such as nanotechnology and MEMS, optoelectronics, etc, can be regarded as the modern day equivalent of the instrument makers of Victorian times. Sensors lead to better quality, economy and efficiency by:

- playing a decisive role in modern process industry and manufacturing industry for automatic measurement and process control
- integration in many modern products for measurement, monitoring and control throughout the whole product lifecycle
- use as an interface between information networks and “reality” for the exchange of information signals in an extended IT-society [10]

The emphasis in much sensor development is on precision – obtaining measurements, perhaps in harsh environments, of a variety of quantities. These are perhaps not only individual physical

quantities, but also “new” quantities – like smell – which do not easily fit into fundamental physics but are nevertheless essential.

Another multidisciplinary aspect of metrology is illustrated in Fig. 2. Such a matrix emphasises that metrological traceability in one sector—say the food industry—may place demands not only on obvious ‘chemical’ quantities such as the amount of substance, but also at the same time on traditional physical quantities such as mass or electrical quantities. Similarly, the development of measurement science in relation to one particular quantity may also have bearing on the corresponding development of metrological traceability of another quantity. There are indeed many similarities between metrology in chemistry and physics and this facilitates in the widest sense comparison of the measurement of different quantities [5].

Planning the European Metrology Research Area with the help of the Physicist

Considering the development to date of the SI, which has gone hand in hand with the progress of physics, it is natural to contemplate the ways physicists may collaborate with metrologists in the future and suggests a more co-ordinated approach as one way of solving the dilemma facing international metrology.

Physics and Metrology in the European Research Area

The European Commission in planning its vision of the European Research Area as one of the main elements of the current 6th framework programme of research in the European Union [11], has sought European added value, where:

- ‘critical mass’ of a particular research project (financial and human resources) exceeds means of single country
- complementary national skills are combined, particularly in interdisciplinary situations
- Cross-border nature of problems (e.g. environment, etc)

In physics, as in metrology, some experiments in research demand truly international facilities – such as CERN. In most cases, however, fundamental metrology research can still be performed on a “table top”. Examples of current European projects:

- **JAWS** – development of a new Josephson Arbitrary Waveform Synthesizer (JAWS) for calibrations of low frequency, low voltage signals of arbitrary waveforms and their root-mean-square values (AC/DC standards) [12]
- **Watt balance** – under the co-ordination of the French NMI with the aim of replacing the present definition of the SI kilogram, and where amongst others Sweden contributes with its competence in nanometric surface analysis [13]
- **Optical frequency comb** – a new project inspired within the CCL network, and aimed at developing an optical waveform synthesiser with applications in microwave photonics, arbitrary waveform synthesis in electrical metrology as well as a possible future re-definition of the SI second through linking microwave and optical frequency metrology [14].

“Federated excellence” – ensuring the multi-disciplinarity of metrology

Metrology is multi-disciplinary in essence. In formation, metrology draws on potentially all realms of physics: In application, metrology enables measurements of potentially all quantities to be related to one another in a true and absolute sense – that is the key of metrology.

In planning for a European metrology research area, it is natural therefore to arrange for research environments where as many measurement quantities are maintained and developed in synergy. It may not be necessary to have primary metrological facilities in all areas, but secondary metrology in house in one measurement quantity leads to improved primary metrology in another measurement quantity.

We have also seen how, in the dynamic development of the SI, the physical emphasis behind each measurement unit evolves

▼ **Table 1:** Some of the SI units [7] and related physics research

Measurement unit	Definition	Realisation/reproduction	Related physics research	Research organisation
second, <i>s</i>	The second is the duration of 9 192 631 770 periods of the radiation corresponding to the transition between the two hyperfine levels of the ground state of the caesium 133 atom.	Primary frequency standards that produce electromagnetic oscillations at a frequency whose relationship to the transition frequency of the atom of caesium 133. Uncertainty of 2 parts in 10 ¹⁵	Atomic precision spectroscopy (Nobel Prize 1989) Laser cooling of atoms (Nobel Prize 1997)	Ramsey, Dehmelt, Paul (Harvard, Univ. Washington, Univ. Bonn) Chu, Cohen-Tannoudji, Phillips (Stanford, ENS, NIST)
ampere, <i>A</i>	The ampere is that constant current which, if maintained in two straight parallel conductors of infinite length, of negligible circular cross-section, and placed 1 metre apart in vacuum, would produce between these conductors a force equal to 2 x 10 ⁻⁷ newton per metre of length.	Volt and the ohm based upon the Josephson and quantum-Hall effects stability better than a few parts in 10 ⁷ . Conventional values for the Josephson constant <i>K_J</i> and the von Klitzing constant <i>R_K</i> .	(BCS) Theory of superconductivity (Nobel Prize 1972) Tunnelling phenomena in solids (Nobel Prize 1973) Quantised Hall effect (Nobel Prize 1985)	Bardeen, Cooper, Schrieffer (Harvard, Princeton) Esaki, Giaever, Josephson (Univ. Cambridge) von Klitzing (Univ. Würzburg)
metre, <i>m</i>	The metre is the length of the path travelled by light in vacuum during a time interval of 1/299 792 458 of a second.	Frequency-stabilised lasers locked to atomic or molecular resonances.	Laser spectroscopy (Nobel Prize 1981) Optical frequency comb (Nobel Prize 2005)	Bloembergen, Schawlow (Univ. Toronto, Bell Labs); Hänsch (Max-Planck Institute for Quantum Optics, Garching); Hall (JILA, Boulder)

from one physical discipline to another – from mechanics, through optics to time & frequency, for the SI metre for instance (Fig. 1). It would therefore be a mistake to give sole rights of maintaining a certain primary physical quantity to just one institute that happens today to have the right competence – tomorrow, physics may lead to a completely new realm.

Arenas for cooperation in Physics and Metrology

Primary metrological research is not, and in the future will not necessarily be, only the reserve of the larger European countries. As long as an individual (even a small) country feels it needs and can afford to perform fundamental physics research on its own terms (albeit often in international collaboration), then it should also be allowed to choose to maintain national metrology competence in its own way. Referring countries to the services of the national metrology institutes of other (usually larger) countries can be a poor substitute to maintaining their own competence in metrology, both for domestic knowledge transfer and international cooperation in accurate measurement, as has been expressed in responses to a recent survey of European stakeholders in Metrology [15].

Metrology benefits from as many independent realisations as possible of a particular measurement – the “more the merrier” – in the identification and elimination of systematic errors. Note that this covers not only several laboratories each using the same realisation, but also independent realisations where completely different roots to a measurement quantity are compared and contrasted. Metrological redundancy is not a luxury but rather a necessity for the future development of accurate measurement.

Examples of existing arenas for collaboration between physicists and metrologists include the CGPM (Conférence Générale des Poids et Mesures) and its various consultative committees; CODATA's working group on Fundamental Constants; and the International Union of Pure and Applied Physics Commission 2: SUNAMCO “Standards, units and nomenclature, atomic masses and fundamental constants” which has a mandate:

“To promote the exchange of information and views among the members of the international scientific community in the general field of Fundamental Constants including:

- physical measurements;
- pure and applied metrology;
- nomenclature and symbols for physical quantities and units;
- encouragement of work contributing towards improved recommended values of atomic masses and fundamental physical constants and facilitation of their universal adoption.”

Perhaps one of the more essential ingredients in improving innovation is the efficient transfer of measurement knowledge, where metrologists act as intermediaries between advances in measurement science and the innovative company [16]. Alongside traditional training courses, there should be increasing attention paid to the educational and knowledge transfer opportunities in collaborations between universities and national metrology institutes.

The ERA-NET iMERA [1] has in fact several tasks addressing stakeholder interaction and knowledge transfer (KT). This gives ample opportunity for spreading awareness and obtaining feedback, and encouraging active participation, from various societal groups not immediately in the measurement research sphere. An initial task has been to organise a European workshop at the end of 2005 which has identified opportunities for the practitioners to improve national KT activities (Task 1.4 in project iMERA [1]).

Conclusion

In meeting challenges to the future of fundamental metrology, it is clear that cooperation between physicists – both pure and applied – and metrologists should be strengthened. ■

About the author

Leslie Pendrill is head of research at the Swedish National Metrology Institute at SP; adjunct professor at the University of Uppsala and the newly elected Chair of the International Union of Pure and Applied Physics Commission 2: SUNAMCO “Standards, units and nomenclature, atomic masses and fundamental constants”.

e-mail: leslie.pendrill@sp.se

web: www.iupap.org/commissions/c2/

References

- [1] iMERA 2005 “*Implementing Metrology in the European Research Area*” www.euromet.org/projects/imera/
- [2] G. Gooday, “The values of precision”, ed. M. Norton Wise, Princeton University Press.
- [3] L.R. Pendrill, *Journal for Quality, Reliability and Comparability in Chemical Measurement*, **10**, 133 - 9 (2005)
- [4] J. Barrow “*From alpha to omega*”, John Cape Publishing, London, (2002)
- [5] <http://nobelprize.org/physics/laureates/1964/>
- [6] <http://nobelprize.org/physics/laureates/1981/>
- [7] BIPM 2005 “*SI Brochure*” www.bipm.org/en/si/si_brochure/
- [8] <http://nobelprize.org/physics/laureates/2005/>
- [9] T. Quinn and J. Kovalevsky, *Phil. Trans. R. Soc. A* **363**, 2307 – 27 (2005)
- [10] L.R. Pendrill, SP Report 2000:12 (2000), www.sp.se/metrology/eurosens/SP-report%202000_12.pdf
- [11] EC 2002 “*The European Research Area – An internal knowledge market*”, European Commission ISBN 92-894-3517-8
- [12] Josephson Arbitrary Waveform Synthesizer: www.jaws-project.nl
- [13] The Watt balance project, BNM-INM, www.cnam.fr/instituts/inm/english/inm.htm
- [14] BIPM CCL 2003 Recommendation CCL-3 (2003) www.bipm.org/en/committees/cc/ccl/
- [15] L.R. Pendrill, SP Report 2003:13, (2003) www.sp.se/metrology/eng/documents/MERA_WP6_SP_Report2003_13.PDF
- [16] DTI, DTI Innovation Report (UK) December 2003 www.npl.co.uk/met/dti_steer/innovation-report-full.pdf

Erratum - Europhysics news 36/6 - page 206

In the Andrea Rapisarda and Alessandro Pluchino article about “Nonextensive thermodynamics and glassy behaviour”, the conclusion has been truncated. You should have read: Summarizing the HMF model and its generalization, the α -XY model, provide a perfect benchmark for studying complex dynamics in Hamiltonian long-range systems. It is true that several questions remain still open and need to be further studied with more detail in the future. However the actual state of the art favours the application of Tsallis thermostatics to explain most of the anomalies observed in the QSS regime. The latter seems to have also very interesting links to glassy dynamics.

A conversation with Sir Peter Mansfield



Following the award of the 2003 Nobel prize for Medicine to Sir Peter Mansfield, Europhysics News arranged an interview with him in the summer of 2004

which took place in the splendid new building in the University Park of the University of Nottingham that houses the MRI instruments and is the centre of his research. The subjects of the interview ranged over his current research and hopes for the future and his thoughts and reflections on a rich and productive life in the application of physics in medicine and as an academic physicist.

The interview was conducted by George Morrison and Jose Marques, a graduate student with Sir Peter.

Magnetic Resonance Imaging is still very much a topic of research in universities while Computerised Tomography moved quickly to industry. How have physics departments managed to keep an important share of the development of MRI?

I believe it all goes back to the nature of X-radiography. You have a hundred years of using X-rays in hospitals internationally and therefore there are years of training and expertise at understanding x-ray images. CT was a development in X-ray imaging and therefore would find more immediate application in a hospital where medical staff are used to looking at X-ray images. With MRI it wasn't just a matter of looking at the different types of image. It was also a matter of understanding the physics behind the images. Many of the radiologists, particularly in this country, did not and indeed still do not understand how MRI works, whereas in America there was a much more ready acceptance of the new imaging modality. There are young radiologists in the United States who are actually helping to push the topic forward, not just through their medical work but because of specialised applications which they are implementing themselves. Typically in Britain doctors don't, generally speaking, study for a PhD. In America they do, so most of their MRI radiologists, medically qualified radiologists, actually have PhDs. I think that's the reason things took a while to catch on here; it was partly the radiologists themselves who held it back. And the reason it stayed in university institutions is

because university graduates in physics and in some cases medical graduates and PhDs have taken over the topic and kept the research side running. The topic expanded very much and got into practical use in America before it entered into use in this country. Although it was invented here we were rather slow. I should say it was partly invented here; Paul Lauterbur did his work but of course it wasn't terribly well received in the very early days, I think he was more or less dismissed as was the technique...

He's gone back to his chemistry now, hasn't he?

Yes, and why he's done that I don't know. I suppose he feels that the topic has gone as far as it's going to go in medicine and there isn't much he can add to it, and perhaps he's right. Perhaps we should all be getting back to other things. I shouldn't say that in front of one of our students...

Oh, no! And just to conclude this matter, what are your own ambitions at present for further developments and improvements in the use of MRI. You have said that in the States a lot of applications and improvements are coming from the actual practitioners...

Well, I've turned into a safety man at the moment. I've always had concerns about the safety of MRI. Those concerns initially were about the use of high static magnetic fields, but there are other concerns; one of the major concerns is the effect of induced currents in the body. When you do high speed imaging the magnetic field gradient is switched on and off very quickly. This passes through the body inducing currents, circulating currents through the body which can actually interfere with the patient's cardiac function...

Pacemakers and things like that?

Well we exclude patients with pacemakers completely; anyone with a pacemaker should not go near a magnet... But with regard to the static magnetic field I was very concerned initially because we just didn't know what the effect of the magnetic fields would be. In the early days the NRPB at Harwell took an interest in this new imaging modality and they set up a committee to lay down guidelines for the use of MRI basically for patients but also for operators of the machine. They set limits for the static magnetic field at about 2.5 Tesla. This was the maximum field permitted. And as far as I know that hasn't changed.

Here we have a 3T magnet and we are expecting a 7T magnet shortly. I am not seriously worried because I don't think I'm ever going to go near that but there is a concern. With these very high fields, because of the flow of blood through the magnetic field, there is a magneto-hydrodynamic effect. You've got a conductive material, blood, which is passing through a magnetic field. Therefore there will be a potential EMF induced across the aorta if you are positioned in the magnet correctly. This potential could interfere with the cardiac function in some way. We know that that actually happens and has been measured. The effect on the ECG has been measured, recorded and published for monkeys, at very high magnetic fields. When I say very high I'm talking about 7 or 8T. We're getting a 7T machine for humans. A monkey is a fraction of the size, so if you start to go to very high fields and you're dealing with large people, then you could have a problem.

That is one effect. The other effect is the effect of the magnetic gradients themselves. If a gradient field is switched very quickly, and we're actually reversing a magnetic gradient field, people have noticed strange sensations in the thorax and the shoulders and so on...

You don't want to be a hypochondriac if you go into one of these things then...

Well you don't want to be that. I've been in the machine and I survived. I've been in a 0.5T machine as well, the one just down the hall. But what I'm saying is that there is a genuine concern about safety but of course you can be overly concerned about these things and worry about them too much...

Its not proven, but the only trouble with such things is, it's the same with mobile phones and living in proximity to transmitters and power lines, it's probably going to be a while before harmful effects show up and are correlated...

Well what I'm saying is that there may not be any effect but it's as well for someone at least to be worried about it.

But can you do anything about it? Is your worry being translated into action?

Yes it is. Not to stop further developments but to do something about the problem. That is what I'm currently concerned about. Actually there are two concerns; first of all there are the electric fields that accompany the magnetic fields and the

electric field component is the one that causes the circulating currents in the body. That is number one concern. But there is something that can be done about it and we've recently published a paper and filed a patent on this. It's all relatively new.

The other concern that I started work on after I took early retirement, so it has been on the go for a bit longer, is the gradient coil acoustic effect. Acoustic effects are really quite serious and can be dangerous. We've managed to reduce the acoustic noise level in a demonstration model by about 50 decibels, which is very good when judged by the standards of other noise reduction techniques...

Is that bringing it down from about 130 to 80 decibels, with 80 being the maximum recommended...?

Yes. But it's very difficult in general to reduce the noise by that much. Many of the techniques which others are pursuing can result in 20 or 30 decibels reduction. No one has been able to achieve 50 decibels reduction. So we think we're on to something worth pursuing. But it's a matter of trying to convince the companies that they should be looking more seriously at our work. At the moment they haven't really taken up the challenge, partly I believe that is because they've got their own research teams. Some companies may have twenty people working on this problem. And I can imagine the senior people in the company saying, "Well, we've got twenty people, what the hell are they doing? This guy Mansfield's come up with one solution to the problem but, why can't we do better?"

Do you still have post-doctoral researchers or graduate students, or are you doing this basically on your own?

I have one student my son in law, Brett Haywood, (now Dr Haywood) so he can't help but work for me.

So these concerns are obviously keeping you very active and very busy!

Can I stop the MRI questions there and move on to more general questions addressed to you as a senior university physicist and one who has obviously, from all we've talked about, wide links with industry. So my first asks how you see the links between university physics and industry in the light of your own experience, and despite some of the frustrations.

I think links between particular research groups and industry are important if they've got something that is going to be of commercial importance but I don't think

that all topics in physics, or indeed in chemistry or whatever have the same level of industrial importance. They may become important with time but one shouldn't be breathing down the necks of our colleagues and saying "You should be working with a

company so that the university can get more money in on the back of your work". I think in the end that's going to be a negative way of looking at things.

There is a tendency to do that, but I think that for those people that are work-

A brief history of MRI

In the early 1970's a new branch of Nuclear Magnetic Resonance was founded with the invention of nuclear magnetic resonance imaging. In the imaging community the term "nuclear" was eventually dropped, mainly due to public relations concerns and the technique is now known as magnetic resonance imaging (MRI). In the early 1970's, it was already obvious that different tissues had different characteristic NMR parameters, but how to transform the information carried by a wave with a wavelength of the order of metres into something that is spatially localised on a much smaller length scale was an unsolved problem.

The first 2D MR images, or proton spin density maps, were produced and published in 1973 by Lauterbur using gradients applied in different radial directions to obtain in the Fourier domain several 1D profiles [1]. The reconstruction was analogous to that developed for Computerised Tomography (CT), proposed in 1963 by Cormack. This methodology was baptized Zeugmatography. The concept was demonstrated with an image of two sample tubes. In the same year Mansfield, coming from a different perspective, introduced the mathematical basis of k-space (also based on gradient encoding), inspired by work on optical diffraction. The experiments were carried out using three separated camphor boards, whose profile was made observable in frequency space by the application of a magnetic field gradient [2].

In 1974 Garroway, Grannell and Mansfield noticed that magnetic field gradients combined with the known frequency selectivity of RF pulses could be used for slice selection [3].

Until 1976 only test tubes and vegetables were imaged using MRI. The first in vivo image acquired was of a student's finger and was published by Mansfield and Maudsley. [4]

In 1977 Mansfield proposed a method where all k-space (used to construct an image) could be sampled in one go, reducing significantly the acquisition times, and it was christened Echo Planar Imaging (EPI) [5]. This technique, due to its large demands on hardware, remained out of the commercial market until the early 90's. One of its advantages has to do with its ability to perform functional studies.

In 1986 Mansfield introduced active magnetic screening of gradients [6], that significantly reduced eddy currents in the body of the magnet, reducing image artefacts and allowing the gradients to be switched faster, which ultimately enabled faster imaging. With the implementation of fast techniques such as EPI and Echo Volumar Imaging, EVI [7] during the last 15 years, which require fast switching of the magnetic field gradients, the noise in the scanners became one of the main dangers related to MRI. Some of the most recent work has been towards studying the origin of acoustic noise and how best to reduce it. [8]

Although MRI has been commonly available in hospitals for the past two decades, only in 2003 were the inventors, Lauterbur and Mansfield, distinguished with the Nobel Prize for Medicine and Physiology.

References

- [1] P. Lauterbur, *Nature*, **242**, 190-191, (1973)
- [2] P. Mansfield and P.K. Grannell, *J. Phys. C: Solid State Phys.*, **6**, L422, (1973)
- [3] A.N. Garroway, P.K. Grannell, P. Mansfield, *J. Phys. C*, **7**, L457 (1974)
- [4] P. Mansfield, A.A. Maudsley, T. Baines, *J. Phys. C*, **9**(4), 271-278, (1976)
- [5] P. Mansfield, *J. Phys. C*, **10**, L55, (1977)
- [6] P. Mansfield, B. Chapman, *J. Magn. Reson.*, **66**, 573-576, (1986).
- [7] P. Mansfield, A.M. Howseman and M. Ordidge, *J. Phys. E. Sci. Instrum.*, **22**, 324-330, (1989).
- [8] P. Mansfield, P. Glover, R. Bowtell, *Meas. Sci. Technology*, **5**, 1021-1025, (1994)

ing with something that has potential in industry right now it's not a bad idea to forge industrial links. It brings in some money for them, it brings in some money for the university and that's all very fine. But if one isn't careful it can also have the effect of creating first and second class citizens within our various departments. People who have grants and additional funding coming in from royalties might be treated differently from those that don't and I do not believe that's a good idea because one never knows. Doctor X down the corridor who has no particular support could come up with some outstanding results. That's my view even though we're in the category that has had support, has patents and has royalty income. The university has done very well out of us and because of that we have this building to which some of that money has contributed. We have been very lucky...

I think it's absolutely essential that universities carry on pure research per se. It would be an absolute travesty of the meaning of Universities if those people that worked quietly in the corner were completely ignored. That would be unfortunate.

To continue on with university links with industry... The Research Councils put money into universities both for pure and applied research so my question is, do you think the balance of funding between the pure and applied in the UK is about right or should industry make more of a contribution to research funding in universities?

I think this idea of trying to squeeze more money from industry as some sort of tax is wrong. Industry is already making a substantial contribution to the total tax take and I believe the only consideration should be whether the work that they are asked to fund is of direct relevance to them, which

goes back to what we said a little bit earlier. I can't see that it would be right and proper to keep using industry as a source of infinite funds that the government themselves can't supply, unless it's something of direct relevance. And I suspect the root cause of the problem is that we have too many universities and as a result the limited funding that is available from the Research Councils such as EPSRC, MRC or whatever, or the charities even, is just not enough to serve the requirements that are there. We have too many takers of the funding. I honestly believe that the move to

turn polytechnics into universities exacerbated the problem very considerably and was a mistake. Whoever was responsible for it was wrong in my view. We wouldn't have half the problem that we have today in creating or obtaining funds for research if we halved the number of universities and called them polytechnics again.

Of course you have the American example where practically everybody goes to university but to some extent, apart from the best universities' undergraduate courses, they are somewhat akin to our sixth form colleges. But that is an aside.

Can I move on then to another problem. There is, I think mainly in the developed world, a widespread suspicion and mistrust of science and the scientist by the general public, of everything the scientist does. It's not just nuclear energy or GM crops, it's so many things, to some extent in ignorance, that the public comes out against. It seems that there is a general suspicion and mistrust of science and the scientist. Do you agree with my statement and if so do you have any ideas for addressing this problem?

I think there is a mistrust of science because there are a number of examples where the scientists have got it wrong or if they haven't got it wrong the politicians interpreting the scientists have got it wrong. One of the examples I can readily recall is the BSE crisis where I think the government of the day were so wrong in what they said. It's that sort of thing that's created the mistrust. I mean if you can get something that wrong...

But was it the scientific advice they were getting...? The government was acting on scientific advice presumably...

Well yes, but they can take advice from a whole range of people. Maybe the people that were giving them advice at the time got the whole thing cock-eyed and therefore major, major errors were made. I think that's one area, BSE. Another one, is AIDS, where they've got that wrong, I mean if they had taken a different approach to AIDS instead of a laissez faire approach then maybe we wouldn't have the problem we've got today. But again this is all political correctness and you mustn't criticise anyone that the government decrees shall not be criticised. It is considered *infra dig* to say anything about AIDS in any public way. There are a number of important issues like our approach to AIDS that are not talked about.

Another problem in medicine that is not directly related to that sort of illness is



◀ **Fig. 1:** Sir Peter Mansfield receiving his Nobel Prize from His Majesty the King at the Stockholm Concert Hall.
© Hans Mehlin, Nobelprize.org

asbestosis. There is such a long history of company neglect back in the 1930's I believe and hundreds, even thousands of people have now got problems with breathing and so on related to asbestos which could have been completely prevented by action at the time.

Was the link known at the time?

Yes. There was a relationship established between cancer of the lung and asbestos particles. It was mainly blue asbestos that was the problem. This was all known and has been documented but was suppressed, not only by the companies that knew about it but by the government also. So that's another area, and I can think of other industrial illnesses. Take the coal miners for example. They are still, even today, 10, 15 years after their coal mines have been closed, still fighting to get compensation for the industry-related health problems that they suffer from. I don't know if that answers your question but these are all highly contentious areas I believe.

Some of what you're saying is that there is scientific evidence but it has been overlooked. We don't know the real truth of GM crops but there are very strong militant groups who are against. Do you think it would help if there were more initiatives to further public understanding of science. The public, to a large extent, doesn't know what to believe and so some of the mistrust is there because as you say there are these terrible outcomes that are blamed on the scientists...

I don't think that it's the scientists all the time. I think the government of the day has a very important role; it's their job to disseminate information that affects public health and variously they have chosen not to do this.

So the scientists are getting the blame that in a way it leads to this mistrust...

Well, it's either government or it's the big business organisations; it's most often not the scientists who are working on the bench, but the people above them who decide if they will use or ignore results. We've seen examples in the coal industry, the asbestos industry and we could for all I know be seeing it now in the telecommunications industry where they're saying generally speaking that microwave radiation is not a problem... And they're desperate to do this because it's such a big money spinner. But then, if it is a problem who's going to pay?

So I don't blame the scientists so much as the politicians or the administrators of

companies who see it as a major threat to their business if information is leaked out, because it could close down a particular interest that they have.

You've been a FRS for some quite considerable time. Do you think the Royal Society could do more to give its views and to take a more proactive, visible role in educating the public or are they just going to be damned with "They would say that, wouldn't they"?

I believe they are trying to take a more proactive role in informing the public about scientific affairs, to give them credit. They are actually trying to do this at the moment. Take their deliberations on GM crops for example. I think their advice right now is that one out of three of the particular examples that they consider is okay. The others require us to be careful in the sense that the jury is still out.

The Society is certainly taking a more proactive role than say five, ten years ago and to some extent this may be due to their current President who is a very pro-active individual. Do you get much involved in the morality of science questions?

Not really. I've not been asked and I'm not volunteering.

Another problem for science, perhaps tied in with the public perception that we have been discussing, is the fall in student numbers entering physics, chemistry and the engineering sciences. This is occurring across Europe. Should we attempt to understand and arrest the fall or should we just leave the take-up of university places to market forces? Eventually if there is a need for such trained individuals and there's only a few of them then presumably they will be paid more money and students will then go back into these subjects again?

I can really only speak about Britain on this matter, but it does seem to me that the reason why people are losing interest in entering science as a career is because it doesn't receive the right remuneration. I mean you can do almost anything else but science and end up with a better salary and a better standard of living in Britain. So it might be simply to do with remuneration levels and the reticence of companies to pay scientists because there are too many scientists around...

And this impinges on to the grand proposal of the Government in this country to have half of our school leavers go on to university. That's going to make matters worse not better. So you'll end up with a situation where refuse collectors will be on a better

salary than graduates. It's a situation that's been allowed to build up and perhaps it's done for a purpose; to keep these people down because they are, or can be, a very vocal group and may be a thorn in the side of the powers that be.

To reverse it is clearly very hard because the new universities, the 'poly universities', obviously have a vested interest in continuing to be universities and putting on university courses. It's a very strange development since what is needed you might say are more artisans but then nobody wants to become lower in the British class system...

Well I think the only solution to the problem is to accept the new universities as universities in name, but to rename, think of another word, for the old universities. Call everything else a university and then come up with a new name for a select number. I don't know what that name would be. Perhaps the Omniversities.

Can we move on to a couple of last questions? I'm sure you've heard it said, perhaps most often from your biological friends, that the last century was one of physics and

Vitae

Peter Mansfield was appointed Professor of Physics at the University of Nottingham in 1979, having been a physics faculty member since 1964. He became an Emeritus Professor on his formal retirement in 1994, although this was a retirement in name only, one that relieved him of his teaching responsibilities and allowed him to concentrate full-time on his MRI research interest. During the course of a long and distinguished career in the development and application of MRI, Sir Peter has been the recipient of numerous Honours and Awards. He is the recipient of Honorary Doctorates from the Universities of Strasbourg (1995), Kent (1996), the Jagellonian University, Krakow (2000) and Nottingham (2004). He was elected Fellow or the Royal Society in 1987 and was knighted in the New Year's Honours for 1993. In 2003 he received the ultimate accolade, the joint award with Professor Paul Lauterbur of the Nobel Prize for Medicine for their discoveries concerning Magnetic Resonance Imaging.

A detailed curriculum vitae and autobiography may be found at:
<http://nobelprize.org/medicine/laureates>

that the present one will be the century of biology. Do you agree or may the distinction become less clear-cut with life scientists requiring a background in physics and vice versa? You, yourself have a foot in both camps...

I believe the interdisciplinary move will continue, although I think that it will still be a good idea to keep the basic physics, chemistry, mathematics and biology separate in the training stages. But in the actual operation of research the interdisciplinary trend has already started. We've been doing it for years now, working with medics and biologists, and it will continue. An interdisciplinary approach is actually a very good one because it brings completely different basic training skills to a problem and has resulted in major advances in science, including DNA. Crick, I believe, was a physicist and Watson was a zoologist. So it started that long ago, maybe earlier. So I think that the interdisciplinary approach is one that should be encouraged. But I'm a little bit concerned about the way that funding for research may go. We've been very fortunate over the years in getting, as physicists in a physics department, medical research funding. But it may be a lot harder as time goes on for people to do that. Because there have been funding shortages and so on in the MRC. There has been perhaps a pulling in of horns so that MRC is looking now to fund more medical research by medics instead of taking an interdisciplinary approach, and I think that's unfortunate. What we need in this country is for there to be, maybe as a start, a certain fraction of MRC funding, a fraction of physics funding, a fraction of chemistry funding going together into some new funding agency which specifically deals with interdisciplinary research. That doesn't exist at the moment but it could be a way forward. Certainly not abandon funding of individual areas, but see how it goes with an additional funding agency.

Of course at the undergraduate level, in an effort to attract students into physics, there are many more sorts of interdisciplinary physics courses on offer such as physics with medical physics, physics with biological sciences, physics with chemistry, etc than there were when you and I did physics. Then it was physics and that was it. And this is leading to a more interdisciplinary approach even at an early stage...

But my concern at the moment is that for all these people with these mixed degrees, with a core in physics and something else

tagged on, there isn't any way that they, as professionals, can go and ask for money to do their interdisciplinary research.

My last question concerns your award of the Nobel Prize. It's still a comparatively short time since this was awarded which, if you'll forgive me for saying, you seem to be taking in your stride. But I, and I am sure people reading this interview, would be interested to know what has it meant personally to you?

I'm going to give you an accurate and proper reply to this. I could be flippant and say not a lot. I think it's been, and this is a purely personal thing, it's been a triumph from my point of view over the detractors, and there were many in the past. I'm not talking of the detractors who were saying "Oh, you'll never get a Nobel Prize" but the detractors in the MRI field and elsewhere, who were commenting in the early days on what we were doing and saying "Oh, it'll never work" and when we showed them an image "Oh, well it works on a finger but of course it won't work on a head" and then you produce a head image and "Oh, well that's fine but you'll never be able to look at the heart". We've had to put up with such comments all these years. So I think receiving the ultimate accolade puts everything right so far as I'm concerned. All the irritation that we've had to suffer over the years, it's all behind us and that gives me a lot of personal satisfaction.

Would you also say that it's given you more work?

Well it has, yes, that's the down side of getting such an award...

You get stupid people wanting to interview you?

No, it isn't so much that, that's a relatively minor thing, but I'm now fair game to be asked to do all sorts of things, and quite a bit of travelling abroad is called for and that's a problem. I've been invited to go virtually all over the world and I can't do that because I'm not 100 per cent medically fit. There was a time when I was travelling all over the world and I remember spending forty-five - fifty days in one year out of the country. But I couldn't do that today. It's a pity that I can't go and spread the word and help on that side. I can do it to a limited extent, and going to Europe is no big problem, but going for any distance like Japan would be. I couldn't go to a big conference in Japan recently. The organisers made a big effort and put on a big show for Paul Lauterbur and me. I'm not sure of all that they arranged because I wasn't there, but

I've been told that they had movies running all the time, in the corridor and in the main room, where everyone was taking coffee breaks. And they did that because Paul didn't go and there was no way I could go. So they put all this on for our benefit and we are obviously very grateful that they did this. But they must have got sick of the sight of us after a while!

The additional work it brings seems to be a common experience. In a previous interview for EPN that we had with Professor de Gennes, he said that winning the Nobel Prize had resulted in 7-10 hours work a week. It is a huge responsibility. You may find this hard to believe but I didn't know I was going to get the Nobel Prize. There was talk in certain articles and journals 10 years ago that we might get it and in one of them, I forget which journal it was now, there was speculation on who might get it. There was a list of people mentioned and I was one of them. But I think after that article, and particularly after hearing the sort of stories that you've just mentioned concerning de Gennes, I felt myself that I was probably better off without it than with it. It was daunting when I heard the news. You can refuse it of course, but I didn't! And that's the thing at the end of the day; I could have said, "No thanks, I don't want it." However I didn't turn it down I accepted it...

Well it represents a great deal, the perseverance, the breakthroughs, the co-workers, the whole history of forty, fifty years of research... But then at the end of the day I'm left with the problem of handling this because everyone else here isn't under the same pressure that I'm under. Interviews apart, I'm getting invitations to go here, there and everywhere and it may sound fine to some of our PhD students that you're being invited to go to this, that and the next place, but at the end of the day you have to be fit to do that... So I'm beginning to feel the strain. However, I have said that after one year I would be very circumspect about accepting invitations to do anything, and I am trying to be so.

Well I am afraid that our visit has brought you some additional work....

This has only been a couple of hours and it's been a pleasurable experience for me to meet and talk with you so I don't think you should feel that it's added anything to my load. I've got much more onerous tasks to consider.

Well from our point of view it really has been most interesting and stimulating, so thank you very much indeed. ■

Exhibition in Bern:

"Meeting Einstein - Understanding physics"

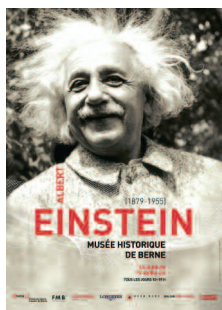

In the frame of the International Year of Physics and to celebrate the Centenary of Albert Einstein's Relativity Theory, formulated in 1905, the Historisches Museum in Bern has organized one of the most lavish cultural exhibitions ever held in Switzerland. Open on 16 June 2005 the Einstein Exhibition has encountered such an extraordinary success - over 140'000 visitors in five months - that it has been prolonged now until 15 October 2006 instead of the originally planned date of 17 April 2006. With its special programme of events, with an outdoor Physics Theme Park and a special Energy Show the Historisches Museum has attracted a broad public from Switzerland and abroad. 'The interest of schools of all grades has been unusually high: by the end of September, some 650 school classes have visited the exhibition' say the museum's organizers and its Director Peter Jezler. Even the participants to EPS13, the general conference of the EPS, could appreciate during a special visit on 11 July 2005 the quality of this scientific exhibition. A range of original objects, documents and installations, displayed over 2,500 m² of exhibition space, present the life and work of Albert Einstein. This well recognized genius was a citizen of the world of Jewish origins with Swabian roots and a Swiss passport. In the historical part of the exhibition it is possible to follow Einstein's life and career in the context of world history. In the second part, devoted to physics, Einstein's revolutionary theories are presented in a vivid and easy-to-grasp way.

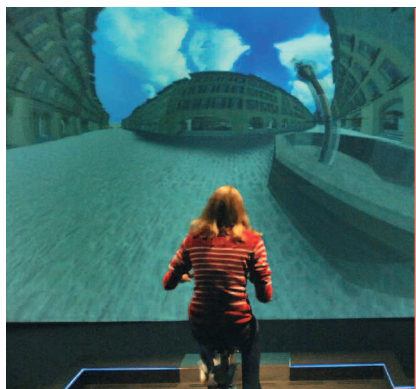

A large part of modern technology, from laser techniques to the use of atomic power and accurate navigation through GPS, rests on Einstein's theories. The highpoints of the event include a virtual bicycle ride through Bern at up to 99 % the speed of light, and a cosmological theatre that takes the visitor on a journey from the earth through space and time right back to the Big Bang.

In the Physics Theme Park around the museum building, some of the most important discoveries and inventions of mankind from the Stone Age to the scientific breakthroughs of the *annus mirabilis* 1905 are displayed in a literally tangible and easily comprehensible way. All the models and tools are presented with a 'hands on' approach: visitors are invited to try them out for themselves - an intriguing field of activity with astonishing experiences and discoveries for young and old alike. For a whole week in August the Museum staged an Energy Show in an arena with 1500 spectators in front of the museum building. This fascinating review astonished the public with breath-taking effects and magical images, mixing physics and the performing arts.

The Exhibition originated as a co-production with the City of Ulm, where the 125th anniversary of Einstein's birth was commemorated with an exhibition in 2004. Cooperative work on the physics part of the Exhibition has already been underway for several years under the direction of Prof. Hans Ruder of the Institute for Theoretical Astrophysics at the University of Tübingen. The archival film footage on the history of the period was prepared by the Berlin documentary filmmaker Irmgard von zur Mühlen. Exhibition design is the expert work of set-designer Raphael Barbier.

During my several visits to the museum I was really amazed and overwhelmed by the numerous pictures, films, letters, documents, manuscripts, and of course the description of Einstein's theories accessible to a general public, presented in very modern and appealing way. All exhibition texts are in German, French and English. It is also possible to rent an audioguide with

◀ **Fig. 1:** Experiencing light velocity through a virtual bikeride across the city of Bern. One of the interactive installations in the exhibition. Picture: Historisches Museum Bern / Franziska Scheidegger

seven languages to help you across the museum or to follow a public guided tour. The Historisches Museum is open daily from 10:00 to 19:00. The physics Theme Park will be closed during winter time and reopen on 15 April 2006. ■

Christophe Rossel,
IBM Research GmbH • Zurich Research
Laboratory • CH-8803 Rüschlikon

Further information and how to get there can be found in the webpage: www.bhm.ch

Science Exhibitions and Museums Review

The EPN will open this year a new rubric under this label. It is no secret to all of us that one major vector of public outreach is provided by science museums and focussed exhibitions. Who has not once in his life experienced the charm and magic of a live performance such as 'physics on stage' or enjoyed the excitement of an interactive experiment on physics, chemistry or other natural sciences in a museum? At a time when technology has deeply invaded our lives and keeps modifying our behaviour, the need for information on the side of the public and young children is in constant increase. This enthusiasm is well demonstrated by the positive responses that were triggered by the many actions and events organized worldwide during the International Year of Physics.

It is our wish to create within EPN a platform to exchange information on public outreach activities in Europe. If you hear or read about an interesting exhibition, museum, or events in your country, you are welcome to send us a short description with your personal comments. In addition try to provide the Internet links of the concerned organisation with practical information that cannot be published in EPN, such as detailed program, opening days and hours, price, etc. An appropriate search engine is for ex. www.google.com where you can type the keywords of your request.

Send your information or comments to the Europhysics news Editor:
Claude.Sebenne@impmc.jussieu.fr

Minding the Heavens,

The Story of Our Discovery of the Milky Way

To those of us living in light-polluted large cities, the spectacle of the glowing Milky Way is, sadly enough, usually absent from our nighttime experiences. For the people of earlier ages, in contrast, it must have been one of the most prominent features and puzzles in the sky. The story of how we revealed the architecture of the universe at large scales, notably how we discovered that we inhabited a (disk) galaxy outlined by the “kiklos Galaxias” of the Greeks, is masterfully told in Leila Belkora’s book *Minding the Heavens*.

The composition of this book is highly unusual: it is centered upon seven biographical essays of individual astronomers who contributed most to our understanding of the Milky Way and the universe of galaxies, from the mystical philosopher Thomas Wright in the XVIII century to the modern observer Edwin Hubble in the twentieth. Some of these are rather well-known, at least in scientific circles, such as Hubble, Shapley, or Herschell; other far less so, in particular William Huggins and the forefather of that remarkable astronomical dynasty, Willhelm Struve. The presentation is somewhat uneven, since although most of the book reads like a serious monograph on the history of astronomy, there are parts (especially in the introductory chapters, preceding the profiles), which are written on a much less advanced level as though having an entirely different audience (high-school pupils, say) in mind. The core of the book, however, performs its task splendidly enough. Research and teaching experience of the author enabled her to give a wonderfully detailed cross-section of the most important pieces of the puzzle of the structure of our stellar system: why does the Milky Way look planar in the sky, and yet nearby stars show an almost homogeneous spatial distribution? Can we use star counts to reveal the structure of our stellar system? Is our Sun located near the center or on the periphery of that system? And, finally: is our stellar system a unique celestial object, or just one of billions of similar “island universes”? All these (and many other) secrets are uncovered in the course of approximately two centuries of astronomical and astrophysical development chronicled in Belkora’s book through the lives of Wright, Herschell, Struve, Huggins, Kapteyn, Shapley, and Hubble.

In addition, there is a lot of background material, which makes an interesting, and at moments, quite amusing reading. We learn with surprise and pleasure of Thomas Wright’s arduous travels across Britain by foot, William Huggins’ sexist attitude toward women in science, or Edwin Hubble’s surprisingly modern-sounding political activism (he even argued for a world-wide police force on moral and humanitarian grounds).

This story Belkora tells is also valuable for its epistemological lessons. It is sobering to re-learn in a case study how often have experienced astronomers “observed what they wanted to observe”, giving false empirical support to one or another theoretical view. The case of Van Maanen’s measurements of the rotation of spiral “nebulae” (offering false comfort to those arguing that these objects are indeed nebularities within our own Milky Way galaxy) is notorious enough, but it is important to keep in mind, as Belkora reminds us, that Lord Ross somewhat earlier committed exactly the opposite mistake in claiming that he observationally resolved the Orion nebula into individual faint stars. Fortunately, she does not cultivate a sort of epistemological relativism that reigns, sadly enough, in much of the contemporary history of science. She does not shy away (and quite fairly, in the opinion of the present reviewer) from stating, e.g. that Struve was “both correct and ahead of his time” (p. 160). Undoubtedly, this will bring accusations of writing a “Whiggish” history of science; hopefully, this will not discourage such informative and worthy enterprises in the future.

This is not to say that *Minding the Heavens* is flawless. Apart from the already mentioned unevenness of style and depth, perhaps the most annoying feature of the book is the relative absence or downplaying of the discovery of the interstellar medium which proved a “missing link” in building a coherent account of the Milky Way as a galaxy. It could be argued that Belkora’s treatment of the Swiss-American astronomer Robert Trumpler (1886-1956) in a single paragraph is too brief and laconic to be satisfactory. Trumpler is one of the unsung heroes of modern astronomy who in 1930 detected and measured extinction (combined effects of absorption and scattering by interstellar dust grains) of starlight passing through the Galactic disk. Through

this magnificent study, he finally resolved the basic conundrum of all attempts to derive the structure of the Galaxy from star counts (or Herschell’s star gauges): the fact that our best observations give *prima facie* isotropic distribution of stars, camouflaging the complex hierarchy of stellar systems. Belkora follows this story not without drama and suspense, but she suddenly retreats in face of Trumpler’s eventual resolution and announces it in quite a low voice.

The volume itself is robustly made, as well as aesthetically pleasing. The book is beautifully illustrated and has a color inset with some of the best astronomical photos in full color, though this should not diminish the beauty of the hand-drawn diagrams and schematics.

All in all, *Minding the Heavens* is an informative and serious contribution to the history of astronomy, and will present a valuable addition to the libraries of both professional and amateur astronomers, historians of science and all those interested in the history of ideas and the structure of our world on the grand scale. ■

Dr. Milan M. Ćirković,
Astronomical Observatory of Belgrade ·
Serbia and Montenegro

Leila Belkora, Institute of Physics
Publishing, 2003, 406 p • € 20.39

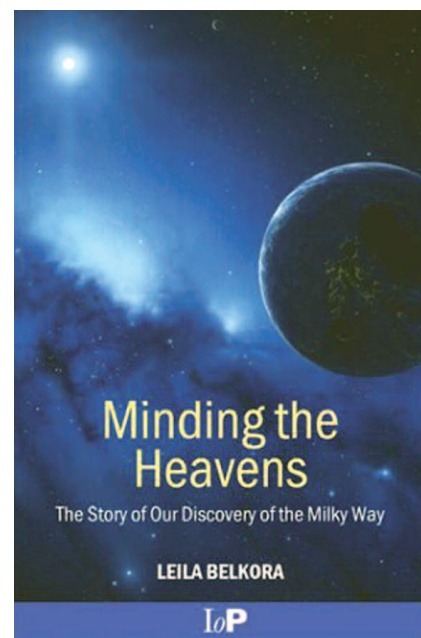

Capillarity and Wetting Phenomena: Drops, Bubbles, Pearls, Waves

The world of interfacial and capillary phenomena in liquids is a fascinating one. We encounter many effects of this type in our everyday lives. Now we can find a wonderful description of such phenomena in the preface to *Capillarity and Wetting Phenomena: Drops, Bubbles, Pearls, Waves* which entices us all to science and provides a shining example of how common experiences can be readily converted into profound scientific experiments with nothing more than a certain minimum of interest.

The whole book is in the same spirit, which is very enjoyable and, as the Authors say in the Introduction, is aimed at “an audience of students”. Thus it contains many illuminating examples and sketches but its greatest and undoubtedly unusual merit is the Authors’ natural bent for simplification. Wherever possible, complicated mathematics is avoided in favour of order-of-magnitude estimates and simple calculations. Dimensional analysis is used as much as possible to get rid of irrele-

vant quantities and the similarities with different physical problems are always stressed. Reference is made to both milestone works (like those of the French scientist Henri Bouasse, who inspired the book) and modern literature with adequate cover of both theory and experiment. The pictures included are always self-explanatory and in most cases amazing. As an example I simply mention Fig 9.18 where a drop of liquid water bounces several times on a super-hydrophobic substrate, in the same way that an elastic ball bounces on a solid surface without splashing.

Simplification does not imply that this book is only for students. On the contrary, due to the large number of topics covered, and to the very elegant exposition of the material presented it will also act as a reference for those working in the field.

In conclusion, the intended readers of this book, whether they be soft matter students or scientists or simply the curious, should find therein not just a very good

source of information but also an impressive collection of exciting and simple explanations of very complex phenomena.

As a matter of interest, it should be noted that this is the English version of the original French book which appeared in 2002. In the summer of 2003 I happened to meet two of the Authors and I congratulated them on the book. On that occasion they informed me that the book had been such a great success in France that they decided to authorise an English translation. I can say that all the virtues of the book are only enhanced by the wonderful English translation. Therefore I have no doubts: the English version will have the same success as its French forerunner. ■

Dr. Roberto Cerbino,
Università degli Studi di Milano

P.-G. de Gennes, F. Brochard-Wyart,
D. Quéré, Springer-Verlag, 291 p • € 59.59

Liquid Crystal Elastomers

Liquid crystals (LCs) are remarkable materials. Their properties lie between those of solids and those of liquids: they are not only fascinating in their own right - as examples of systems exhibiting a variety of broken symmetries - but also lend themselves to many practical applications. Paramount among these is display devices - such as the screen of the computer on which I am typing this review.

Elastomers, on the other hand, are rubbers: definitely solid, but capable of very large (up to hundreds of %) elastic deformations. They are made by crosslinking polymers. Some polymers, on the other hand, are themselves LCs, so if one crosslinks a liquid crystalline polymer, one gets a liquid crystal elastomer (LCE). As originally envisaged by de Gennes in the mid 1970s, LCEs are Cosserat media — where the orientational degrees of freedom of the liquid crystal director couple to the positional degrees of freedom of the underlying solid matrix, thus giving rise to a wealth of behaviour, both static and dynamic, that is still not fully understood. LCEs were first synthesised by Finkelmann’s group in the early 1980s.

The present book, *Liquid Crystal Elastomers* by Mark Warner and Eugene Terentjev, is (to my knowledge) the first

monograph on this class of materials. The two authors are uniquely well qualified to write it, having been at the forefront of many key advances in the field and developed many of its theoretical tools.

Let the reader beware: this is not an easy book — it cannot be, as its subject is intrinsically difficult. The effort expended is, however, amply rewarded. The book divides into twelve chapters.

Chapter 1 is an overview of LCEs. The basics of LC and of polymer and elastomer physics are reviewed in chapters 2 and 3, respectively. Chapter 4 summarises classical elasticity theory as will be required in later chapters. Then chapters 5 — 8 present the unique properties of nematic LCEs and their (mostly microscopic) theoretical treatment. The more complex cholesteric and smectic phases are discussed in chapters 9 and 12, respectively. In chapter 10 the continuum theory of nematic LCEs is developed as a complementary approach to the microscopics. Finally, chapter 11, perhaps the most open-ended, addresses LCE dynamics. More technical aspects are relegated to the five appendices. The overall slant is theoretical, but experiment is never far from sight.

Particularly useful are the estimates of many LCE physical parameters, especially those not yet accessible in the lab.

Is this a perfect book? No. I particularly miss a closing chapter where the many open questions interspersed through the text are collected and directions for further research outlined. A few explanations are a little too concise, e.g., the relationship between fixed-strain and fixed-load experiments on page 58, the discussion of a twist wall on page 220, or that of the SmC^* cell on page 340. It is also frustrating that there are fewer and fewer worked-out problems as one progresses through the book. Finally, there is the large number of highly irritating minor misprints. Still, nothing that cannot be rectified in later editions. In short, this book is likely to become a classic: read it, learn from it, and let it inspire you. ■

Paulo Teixeira,
Faculdade de Engenharia, Universidade
Católica Portuguesa

M. Warner, E.M. Terentjev Oxford Uni-
versity Press (2003), 424 p • € 120.79