

# SÄULENORDNUNGEN:

A= Sima (A1 Tympanon)  
 B= Gebälk (B1 Fries, B2 Architrav)  
 C= Säule (C1 Kapitell, C2 Säulenschaft mit und ohne Kanneluren, C3 Entasis, C4 Basis)  
 D= Krepis (D1 Stylobat)

## Griechische

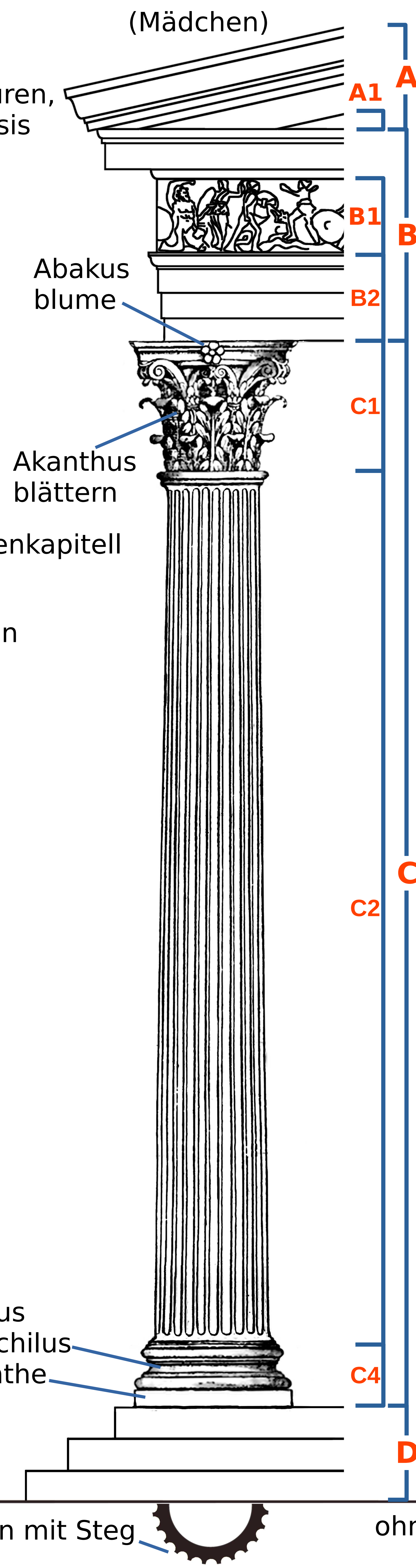
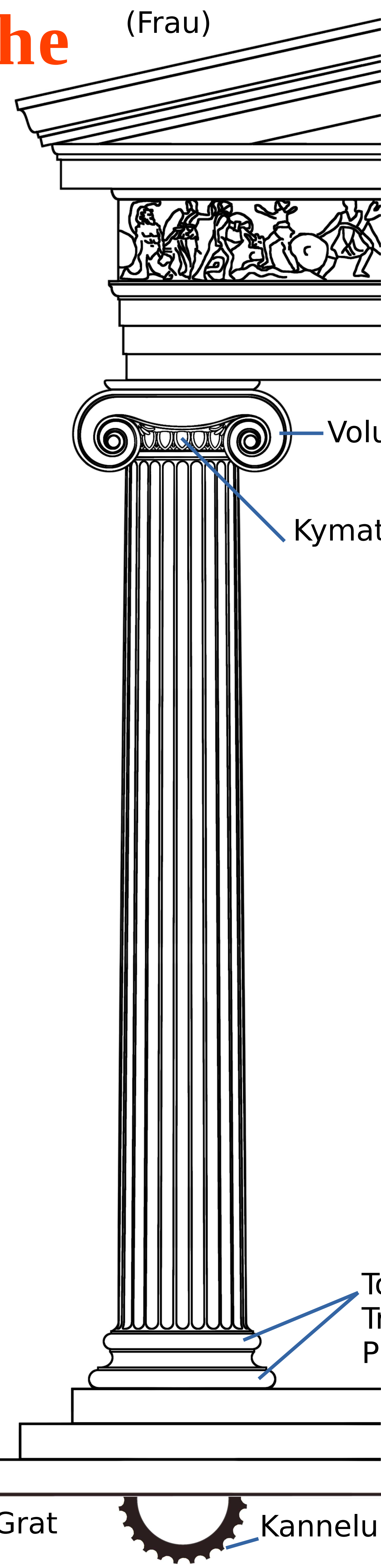
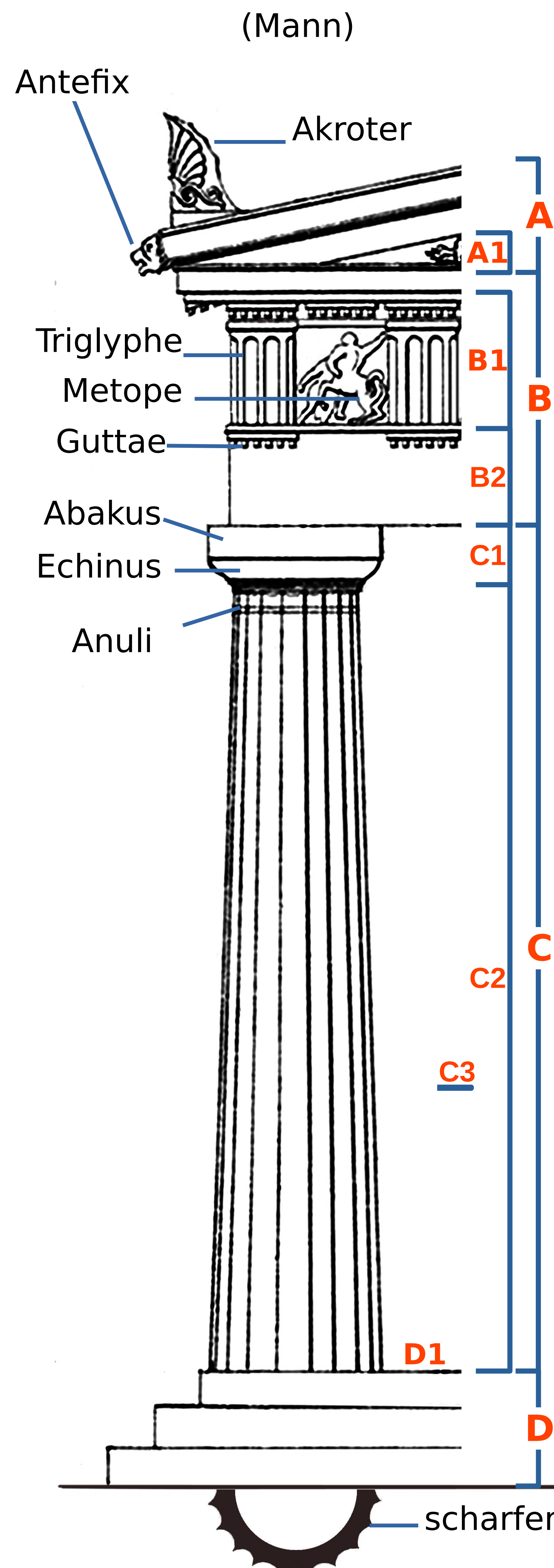

## Etruskische

Paolo-Villa:  
 Zusammenstellung des didaktischen Diagramms, Texte, grafische Zeichen, Modifikation von Bildern (mit: Gimp und Libreoffice).  
 Erstveröffentlichung:  
[https://commons.wikimedia.org/wiki/File:GLI\\_ORDINI\\_ARCHITETTONICI\\_Greci\\_Etrusco\\_Romano\\_\(sche\\_da\\_didattica\\_di\\_Paolo\\_Villa\\_in\\_Commons\\_Wikimedia\\_org\).pdf](https://commons.wikimedia.org/wiki/File:GLI_ORDINI_ARCHITETTONICI_Greci_Etrusco_Romano_(sche_da_didattica_di_Paolo_Villa_in_Commons_Wikimedia_org).pdf)

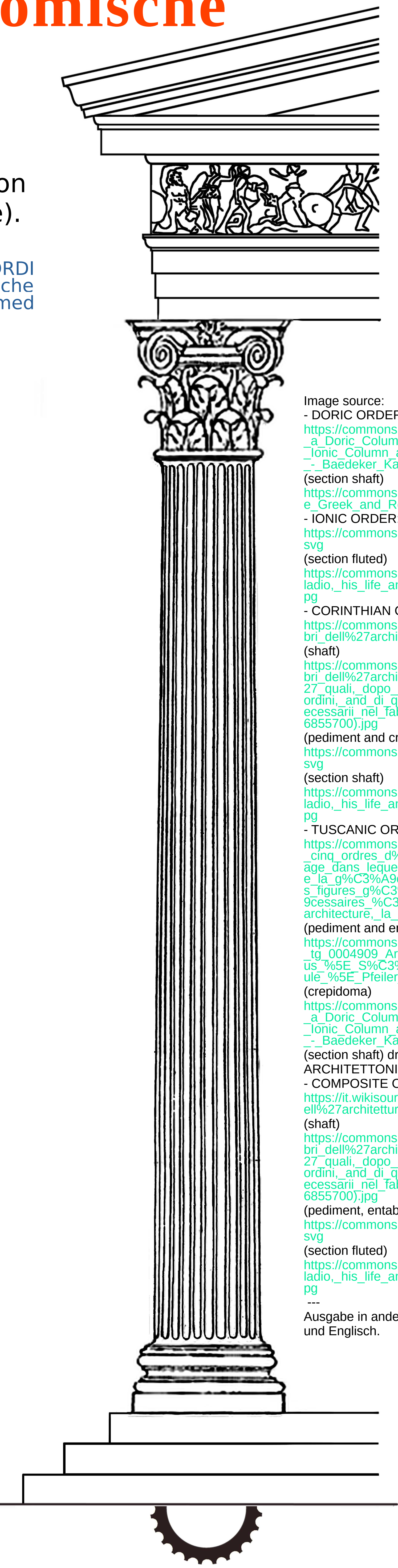
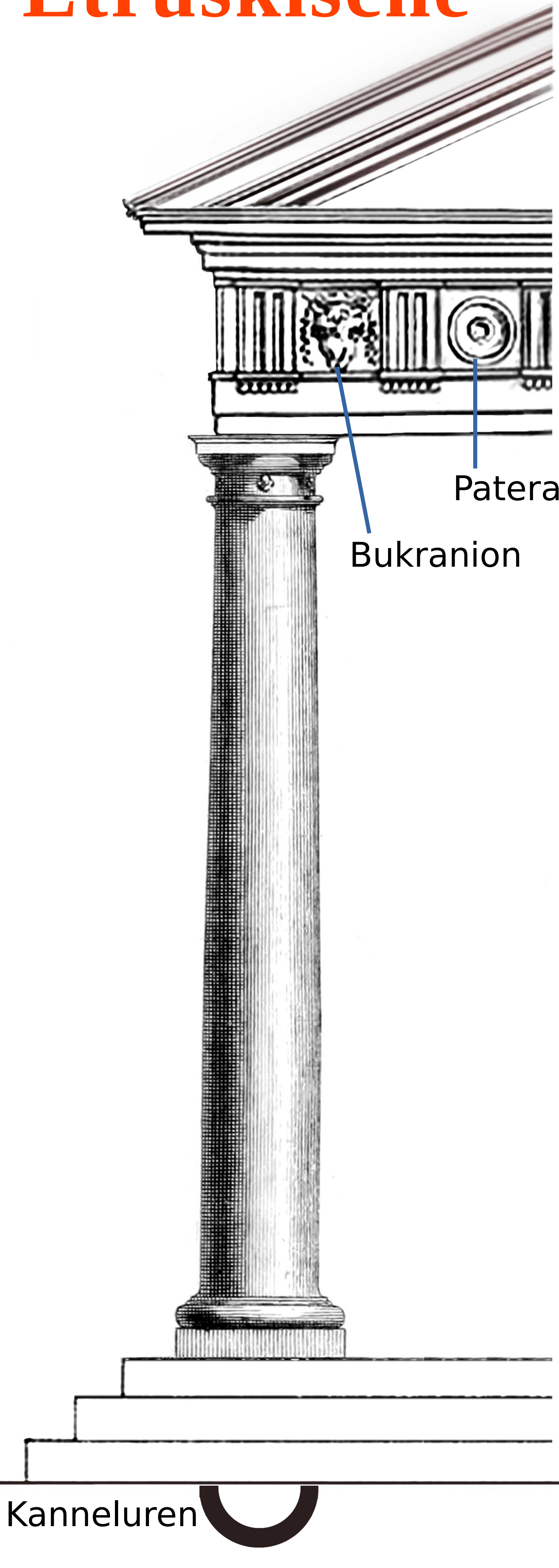

Image source:  
 - DORIC ORDER:  
[https://commons.wikimedia.org/wiki/File:Diagram\\_of\\_a\\_Doric\\_Column\\_and\\_Entablature\\_Diagram\\_of\\_a\\_Ionic\\_Column\\_and\\_Entablature\\_Corinthian\\_Order\\_-\\_Baedeker\\_Karl\\_-\\_1894.jpg](https://commons.wikimedia.org/wiki/File:Diagram_of_a_Doric_Column_and_Entablature_Diagram_of_a_Ionic_Column_and_Entablature_Corinthian_Order_-_Baedeker_Karl_-_1894.jpg)  
 (section shaft)  
[https://commons.wikimedia.org/wiki/File:Comparativ\\_e\\_Greek\\_and\\_Roman\\_Orders\\_160.jpg](https://commons.wikimedia.org/wiki/File:Comparativ_e_Greek_and_Roman_Orders_160.jpg)  
 - IONIC ORDER:  
[https://commons.wikimedia.org/wiki/File:ionic\\_order.svg](https://commons.wikimedia.org/wiki/File:ionic_order.svg)  
 (section fluted)  
[https://commons.wikimedia.org/wiki/File:Andrea\\_Paladio\\_his\\_life\\_and\\_works\\_\(1902\)\\_14577922780.jpg](https://commons.wikimedia.org/wiki/File:Andrea_Paladio_his_life_and_works_(1902)_14577922780.jpg)  
 - CORINTHIAN ORDER:  
[https://commons.wikimedia.org/wiki/File:1\\_quattro\\_libri\\_dell%27architettura\\_\(1790\)\\_pag015.png](https://commons.wikimedia.org/wiki/File:1_quattro_libri_dell%27architettura_(1790)_pag015.png)  
 (shaft)  
[https://commons.wikimedia.org/wiki/File:1\\_quattro\\_libri\\_dell%27architettura\\_di\\_Andrea\\_Palladio\\_-\\_ne%27\\_quali\\_dopo\\_un\\_breve\\_trattato\\_de%27\\_cinque\\_ordini\\_and\\_di\\_quelli\\_auerimenti\\_che\\_sono\\_piu\\_necessarii\\_nel\\_fabricare\\_si\\_tratta\\_delle\\_case\\_\(1458685700\).jpg](https://commons.wikimedia.org/wiki/File:1_quattro_libri_dell%27architettura_di_Andrea_Palladio_-_ne%27_quali_dopo_un_breve_trattato_de%27_cinque_ordini_and_di_quelli_auerimenti_che_sono_piu_necessarii_nel_fabricare_si_tratta_delle_case_(1458685700).jpg)  
 (pediment and crepidoma)  
[https://commons.wikimedia.org/wiki/File:ionic\\_order.svg](https://commons.wikimedia.org/wiki/File:ionic_order.svg)  
 (section shaft)  
[https://commons.wikimedia.org/wiki/File:Andrea\\_Paladio\\_his\\_life\\_and\\_works\\_\(1902\)\\_14577922780.jpg](https://commons.wikimedia.org/wiki/File:Andrea_Paladio_his_life_and_works_(1902)_14577922780.jpg)  
 - TUSCANIC ORDER:  
[https://commons.wikimedia.org/wiki/File:Regles\\_des\\_cinq\\_ordres\\_d%27architecture\\_de\\_Vignole\\_-\\_ouvr\\_ages\\_dans\\_lequel\\_on\\_donne\\_une\\_id%C3%A9e\\_de\\_la\\_g%C3%A9ometrie\\_les\\_d%C3%A9finitions\\_de\\_s\\_figures\\_g%C3%A9om%C3%A9triques\\_n%C3%A9cessaires\\_%C3%A0\\_l%27%C3%A9tude\\_de\\_l%27architecture\\_la\\_\(14581151249\).jpg](https://commons.wikimedia.org/wiki/File:Regles_des_cinq_ordres_d%27architecture_de_Vignole_-_ouvr_ages_dans_lequel_on_donne_une_id%C3%A9e_de_la_g%C3%A9ometrie_les_d%C3%A9finitions_de_s_figures_g%C3%A9om%C3%A9triques_n%C3%A9cessaires_%C3%A0_l%27%C3%A9tude_de_l%27architecture_la_(14581151249).jpg)  
 (pediment and entablature)  
[https://commons.wikimedia.org/wiki/File:Fotothek\\_der\\_0004909\\_Architektur\\_%E\\_Portal\\_%E\\_Portikus\\_%E\\_S%C3%A4ulenordnung\\_%E\\_S%C3%A4ule\\_%E\\_Pfeiler\\_%E\\_Kapitell\\_%E\\_B.jpg](https://commons.wikimedia.org/wiki/File:Fotothek_der_0004909_Architektur_%E_Portal_%E_Portikus_%E_S%C3%A4ulenordnung_%E_S%C3%A4ule_%E_Pfeiler_%E_Kapitell_%E_B.jpg)  
 (crepidoma)  
[https://commons.wikimedia.org/wiki/File:Diagram\\_of\\_a\\_Doric\\_Column\\_and\\_Entablature\\_Diagram\\_of\\_a\\_Ionic\\_Column\\_and\\_Entablature\\_Corinthian\\_Order\\_-\\_Baedeker\\_Karl\\_-\\_1894.jpg](https://commons.wikimedia.org/wiki/File:Diagram_of_a_Doric_Column_and_Entablature_Diagram_of_a_Ionic_Column_and_Entablature_Corinthian_Order_-_Baedeker_Karl_-_1894.jpg)  
 (section shaft) draw by Paolo Villa: GLI ORDINI ARCHITETTONICI: greci etrusco romano  
 - COMPOSITE ORDER:  
[https://it.wikisource.org/wiki/Pagina:1\\_quattro\\_libri\\_dell%27architettura.djvu/65](https://it.wikisource.org/wiki/Pagina:1_quattro_libri_dell%27architettura.djvu/65)  
 (shaft)  
[https://commons.wikimedia.org/wiki/File:1\\_quattro\\_libri\\_dell%27architettura\\_di\\_Andrea\\_Palladio\\_-\\_ne%27\\_quali\\_dopo\\_un\\_breve\\_trattato\\_de%27\\_cinque\\_ordini\\_and\\_di\\_quelli\\_auerimenti\\_che\\_sono\\_piu\\_necessarii\\_nel\\_fabricare\\_si\\_tratta\\_delle\\_case\\_\(1458685700\).jpg](https://commons.wikimedia.org/wiki/File:1_quattro_libri_dell%27architettura_di_Andrea_Palladio_-_ne%27_quali_dopo_un_breve_trattato_de%27_cinque_ordini_and_di_quelli_auerimenti_che_sono_piu_necessarii_nel_fabricare_si_tratta_delle_case_(1458685700).jpg)  
 (pediment, entablature and crepidoma)  
[https://commons.wikimedia.org/wiki/File:ionic\\_order.svg](https://commons.wikimedia.org/wiki/File:ionic_order.svg)  
 (section fluted)  
[https://commons.wikimedia.org/wiki/File:Andrea\\_Paladio\\_his\\_life\\_and\\_works\\_\(1902\)\\_14577922780.jpg](https://commons.wikimedia.org/wiki/File:Andrea_Paladio_his_life_and_works_(1902)_14577922780.jpg)  
 ...  
 Ausgabe in anderen Sprachen: Italienisch, Deutsch und Englisch.

DORISCHE ORDNUNG

IONISCHE ORDNUNG

KORINTHISCHE ORDNUNG

TOSKANISCHE ORDNUNG

KOMPOSITE ORDNUNG