

GLI ORDINI ARCHITETTONICI:

A= frontone (A1 timpano)
 B= trabeazione (B1 fregio, B2 architrave)
 C= colonna (C1 capitello, C2 fusto scanalato o liscio, C3 entasi,
 C4 base)
 D= crepidoma (D1 stilobate)

Greci

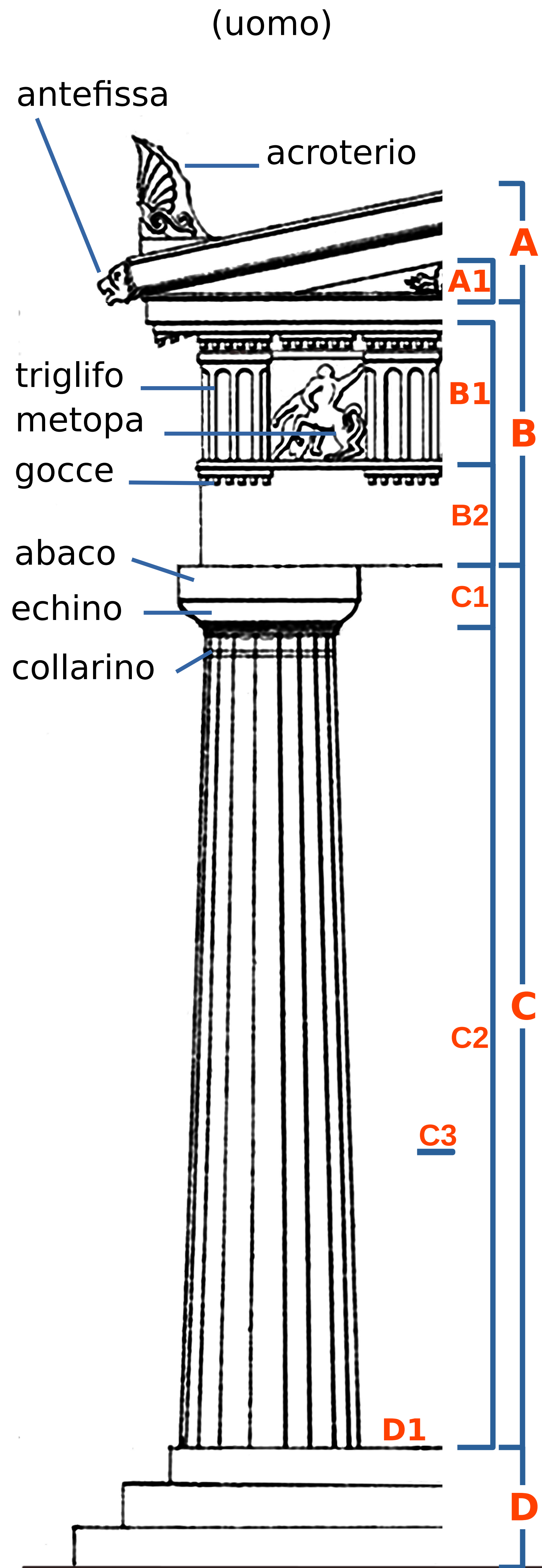

ORDINE DORICO spigolo vivo

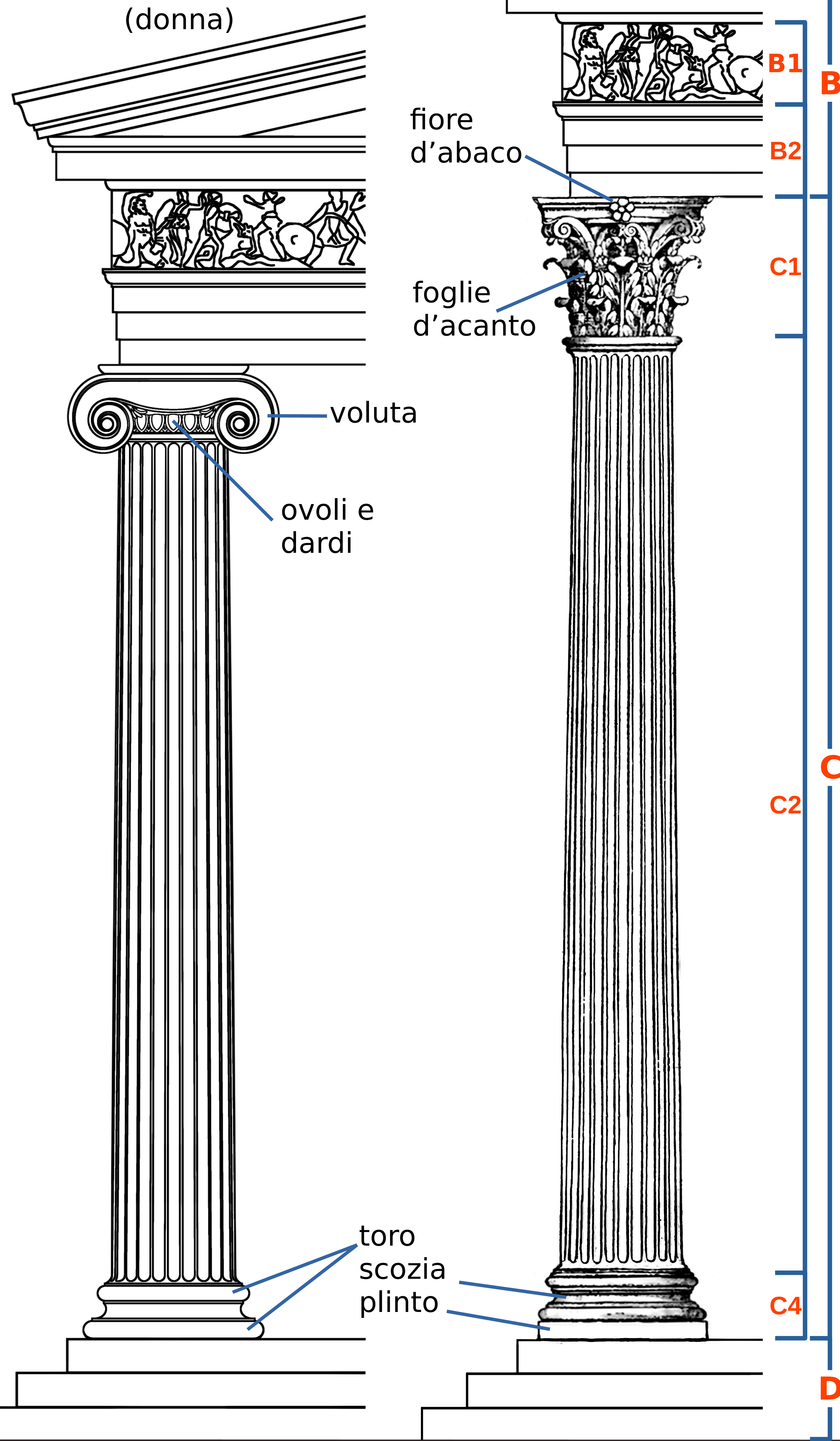

ORDINE IONICO spigoli a listello

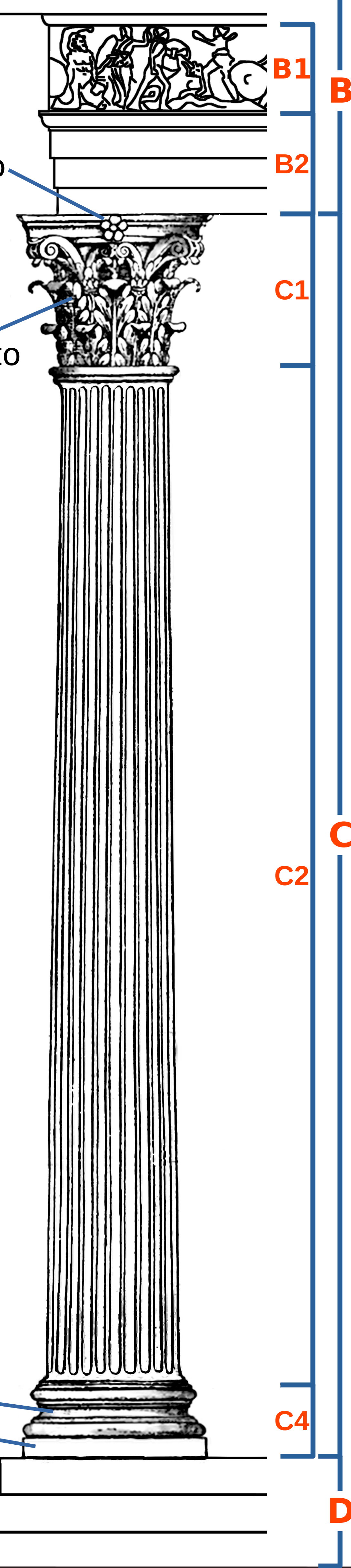

ORDINE CORINZIO

Paolo Villa:
 composizione della tavola didattica,
 testi, segni grafici, modificazione delle
 immagini (con: gimp e libreoffice).
 Prima pubblicazione:
[Commons.Wikimedia.org](https://commons.wikimedia.org).

Etrusco



fusto liscio **ORDINE TUSCANICO**

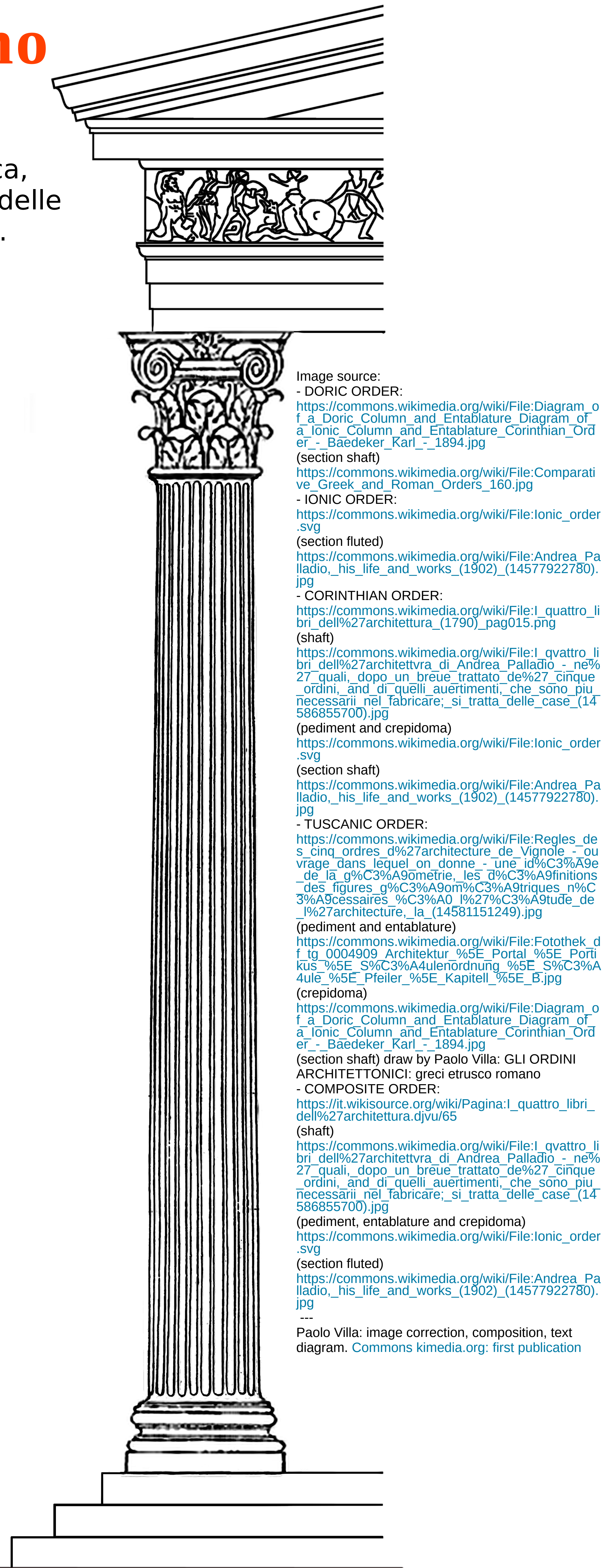

ORDINE COMPOSITO O TRIONFALE

Image source:
 - DORIC ORDER:
https://commons.wikimedia.org/wiki/File:Diagram_of_a_Doric_Column_and_Entablature_Diagram_of_a_Ionic_Column_and_Entablature_Corinthian_Order_-_Baecker_Karl_-_1894.jpg
 (section shaft)
https://commons.wikimedia.org/wiki/File:Comparative_Greek_and_Roman_Orders_160.jpg
 - IONIC ORDER:
https://commons.wikimedia.org/wiki/File:Ionic_order.svg
 (section fluted)
[https://commons.wikimedia.org/wiki/File:Andrea_Palladio_his_life_and_works_\(1902\)_14577922780.jpg](https://commons.wikimedia.org/wiki/File:Andrea_Palladio_his_life_and_works_(1902)_14577922780.jpg)
 - CORINTHIAN ORDER:
[https://commons.wikimedia.org/wiki/File:I quattro libri dell'architettura_\(1790\)_pag015.png](https://commons.wikimedia.org/wiki/File:I quattro libri dell'architettura_(1790)_pag015.png)
 (shaft)
[https://commons.wikimedia.org/wiki/File:I quattro libri dell'architettura_di_Andrea_Palladio_-_ne%27-quali_dopo_un_breve_trattato_de%27-cinque_ordini_and_di_quelli_auertimenti_che_sono_pi%27-necessari_nel_fabricare_si_tratta_delle_case_\(14586855700\).jpg](https://commons.wikimedia.org/wiki/File:I quattro libri dell'architettura_di_Andrea_Palladio_-_ne%27-quali_dopo_un_breve_trattato_de%27-cinque_ordini_and_di_quelli_auertimenti_che_sono_pi%27-necessari_nel_fabricare_si_tratta_delle_case_(14586855700).jpg)
 (pediment and crepidoma)
https://commons.wikimedia.org/wiki/File:Ionic_order.svg
 (section shaft)
[https://commons.wikimedia.org/wiki/File:Andrea_Palladio_his_life_and_works_\(1902\)_14577922780.jpg](https://commons.wikimedia.org/wiki/File:Andrea_Palladio_his_life_and_works_(1902)_14577922780.jpg)
 - TUSCANIC ORDER:
[https://commons.wikimedia.org/wiki/File:Regles_de_s_cinq_ordres_d%27architecture_de_Vignole_-_ou_vrage_dans_lequel_on_donne_une_id%C3%A9e_de_la_g%C3%A9om%C3%A9trie_les_3%27C3%A9nitions_des_figures_g%C3%A9om%C3%A9triques_n%C3%A9cessaires_%C3%A0_%27C3%A9tudier_de_%27architecture_la_\(14581151249\).jpg](https://commons.wikimedia.org/wiki/File:Regles_de_s_cinq_ordres_d%27architecture_de_Vignole_-_ou_vrage_dans_lequel_on_donne_une_id%C3%A9e_de_la_g%C3%A9om%C3%A9trie_les_3%27C3%A9nitions_des_figures_g%C3%A9om%C3%A9triques_n%C3%A9cessaires_%C3%A0_%27C3%A9tudier_de_%27architecture_la_(14581151249).jpg)
 (pediment and entablature)
https://commons.wikimedia.org/wiki/File:Fotothek_d_f_tg_0004909_Architektur_%E_Portal_%E_Portikus_%E_S%C3%A4ulenordnung_%E_S%C3%A4ule_%E_Pfeiler_%E_Kapitell_%E_B.jpg
 (crepidoma)
https://commons.wikimedia.org/wiki/File:Diagram_of_a_Doric_Column_and_Entablature_Diagram_of_a_Ionic_Column_and_Entablature_Corinthian_Order_-_Baecker_Karl_-_1894.jpg
 (section shaft) draw by Paolo Villa: GLI ORDINI ARCHITETTONICI: greci etrusco romano
 - COMPOSITE ORDER:
https://it.wikisource.org/wiki/Pagina:1_quattro_libri_dell%27architettura.djvu/65
 (shaft)
[https://commons.wikimedia.org/wiki/File:I quattro libri dell'architettura_di_Andrea_Palladio_-_ne%27-quali_dopo_un_breve_trattato_de%27-cinque_ordini_and_di_quelli_auertimenti_che_sono_pi%27-necessari_nel_fabricare_si_tratta_delle_case_\(14586855700\).jpg](https://commons.wikimedia.org/wiki/File:I quattro libri dell'architettura_di_Andrea_Palladio_-_ne%27-quali_dopo_un_breve_trattato_de%27-cinque_ordini_and_di_quelli_auertimenti_che_sono_pi%27-necessari_nel_fabricare_si_tratta_delle_case_(14586855700).jpg)
 (pediment, entablature and crepidoma)
https://commons.wikimedia.org/wiki/File:Ionic_order.svg
 (section fluted)
[https://commons.wikimedia.org/wiki/File:Andrea_Palladio_his_life_and_works_\(1902\)_14577922780.jpg](https://commons.wikimedia.org/wiki/File:Andrea_Palladio_his_life_and_works_(1902)_14577922780.jpg)
 ...
 Paolo Villa: image correction, composition, text diagram. Commons kimedia.org: first publication