

Family *Iridoviridae*: Poor Viral Relations No Longer

V.G. Chinchar(✉), A. Hyatt, T. Miyazaki, T. Williams

Contents

Introduction	124
Taxonomy	124
The Viral Genome.....	127
Genomic Organization	127
Viral Genes: Identity and Function	128
Iridovirid Phylogeny	129
Replication Cycle.....	130
Attachment and Uncoating.....	130
Nuclear Events	131
Cytoplasmic Events.....	133
Viral Effects on Host Cell Function.....	137
Host Immune Response.....	140
Biology and Ecology of Iridovirid Infections.....	140
FV3 and Other Amphibian Ranaviruses	140
EHNV and Other Australian Ranaviruses.....	143
RSIV and Other Megalocytiviruses from Asia	146
Invertebrate Iridescent Viruses.....	149
LCDV and White Sturgeon Iridovirus	155
Conclusions and Future Directions.....	156

Abstract Members of the family *Iridoviridae* infect a diverse array of invertebrate and cold-blooded vertebrate hosts and are currently viewed as emerging pathogens of fish and amphibians. Iridovirid replication is unique and involves both nuclear and cytoplasmic compartments, a circularly permuted, terminally redundant genome that, in the case of vertebrate iridoviruses, is also highly methylated, and the efficient shutoff of host macromolecular synthesis. Although initially neglected largely due to the perceived lack of health, environmental, and economic concerns, members of the genus *Ranavirus*, and the newly recognized genus *Megalocytivirus*, are rapidly attracting

V.G. Chinchar

Department of Microbiology, University of Mississippi Medical Center, Jackson, MS USA
vchinchar@microbio.umsmed.edu

James L. Van Etten (ed.) *Lesser Known Large dsDNA Viruses.* 123
Current Topics in Microbiology and Immunology 328.
© Springer-Verlag Berlin Heidelberg 2008

growing interest due to their involvement in amphibian population declines and their adverse impacts on aquaculture. Herein we describe the molecular and genetic basis of viral replication, pathogenesis, and immunity, and discuss viral ecology with reference to members from each of the invertebrate and vertebrate genera.

Introduction

Since their isolation nearly 50 years ago, iridovirids (i.e., members of the family *Iridoviridae*) have been overshadowed by other DNA viruses of medical or veterinary importance, specifically herpesviruses and poxviruses. Although one family member, lymphocystis disease virus (LCDV), has been known for over a century by the wart-like disease it causes in multiple species of salt- and fresh-water fish (Weissenberg 1965), and study of a second family member, frog virus 3 (FV3), has elucidated novel events in eukaryotic virus replication, the perceived absence of commercial, agricultural, medical, or ecological damage resulting from iridovirid infections limited interest in, and study of, this diverse virus family (Williams et al. 2005). Initially, iridovirids attracted interest because of their unusual biology and widespread occurrence in amphibians, fish, and insects. However, within the last 20 years the increased recognition of vertebrate iridovirids as important pathogens infecting commercially and ecologically important fish and amphibian species has attracted the interest of fish pathologists, wildlife biologists, ecologists and others interested in the impact of infectious disease on ectothermic vertebrates (Hyatt et al. 2000; Chinchar 2002; Williams et al. 2005; Mendelson et al. 2006). For example, members of the genus *Ranavirus* were identified as the causative agent in approximately half the documented cases of amphibian mortality reported in the United States between 1996 and 2001 (Green et al. 2002). In addition, viruses in the genus *Megalocytivirus* have been responsible for numerous outbreaks of severe disease in fish farming facilities throughout Asia (Nakajima et al. 1998). Given the growing impact of iridovirus diseases worldwide and the increased use of contemporary molecular approaches to elucidate the phylogeny and life cycle of iridoviruses, it appears that this virus family is finally receiving the scientific recognition it deserves. In this chapter, we provide a summary of iridovirid taxonomy, genetic organization, and replication strategy, followed by a description of the biology and ecology of specific genera and viral species. Additional information can be found in several recent reviews (Williams 1996, 1998; Chinchar 2002; Williams et al. 2005).

Taxonomy

The family *Iridoviridae* is currently classified into five genera (*Iridovirus*, *Chloriridovirus*, *Ranavirus*, *Megalocytivirus*, and *Lymphocystivirus*), each consisting of one or more virus species, tentative species and strains (Table 1) (Chinchar et al. 2005). In keeping with the recent suggestion of Vetten and Haenni (2006), members of the

Table 1 Taxonomy of the family *Iridoviridae*

Genus	Viral species [strains] ^a	Tentative species
<i>Iridovirus</i>	<i>Invertebrate iridescent virus 6</i> (IIV-6), IIV-1	<i>Anticarsia gemmatalis</i> iridescent virus (AGIV), IIV-2, -9, -16, -21, -22, -23, -24, 29, -30, -31
<i>Chloriridovirus</i>	<i>Invertebrate iridescent virus 3</i> (IIV-3)	
<i>Ranavirus</i>	<i>Frog virus 3</i> (FV3), [tadpole edema virus, TEV; tiger frog virus, TFV] <i>Ambystoma tigrinum virus</i> (ATV), [Regina ranavirus, RRV] <i>Bohle iridovirus</i> (BIV) <i>Epizootic haematopoietic necrosis virus</i> (EHNV) <i>European catfish virus</i> (ECV), [European sheatfish virus, ESV] <i>Santee-Cooper ranavirus</i> , [Largemouth bass virus, LMBV; doctor fish virus, DFV; guppy virus 6, GV-6]	Singapore grouper iridovirus (SGIV); Grouper iridovirus (GIV) <i>Rana catesbeiana virus-Z</i> (RCV-Z)
<i>Megalocytivirus</i>	<i>Infectious spleen and kidney necrosis virus</i> (ISKNV) [Red sea bream iridovirus, RSIV; African lampeye iridovirus, ALIV; Orange spotted grouper iridovirus, OSGIV; Rock bream iridovirus, RBIV]	
<i>Lymphocystivirus</i>	<i>Lymphocystis disease virus 1</i> (LCDV-1)	LCDV-2, LCDV-C, LCDV-RF
Unclassified	White sturgeon iridovirus (WSIV)	

^aViral species recognized by the ICTV are italicized, whereas strains or isolates are listed within brackets (Chinchar et al. 2005). Common abbreviations are indicated

family *Iridoviridae* will be referred to collectively as iridovirids to distinguish them from members of the genus *Iridovirus*. Morphologically, iridovirids are large, icosahedral viruses (120–200 nm in diameter) that possess an internal lipid membrane located between the viral core and outer capsid. In contrast to other virus families, a viral envelope, present on virions that bud from the plasma membrane, is not required for infectivity, and many virions remain cell-associated and are released as naked particles following cell lysis.

Members of the family possess linear, double-stranded DNA genomes, which vary in size from approximately 140 kbp (genus *Ranavirus*) to over 200 kbp (genus *Iridovirus*). Iridovirid genomes are unique among animal viruses in that they are circularly permuted and terminally redundant (Goorha and Murti 1982; Delius et al. 1984). For example, if the letters of the alphabet represent the viral genome, analysis of linear genomes from individual virus particles would yield sequences such as **ABCDE...UVWXYZABCDE, CDEFG...WXYZABCDEFG, FGHIJ...ZABCEDFGHIJ**. Because the terminal repeat region accounts for 5%–50% of the genome length, the total length of each genome (e.g., 140 kbp for a typical ranavirus) is more than the length of the unique region (e.g., ~105 kbp).

The five iridovirid genera can be partitioned into two groups (that in the future may be classified as subfamilies) based on the hosts they infect and the level of genomic methylation (Chinchar et al. 2005). Members of the genera *Iridovirus* and *Chloriridovirus* infect invertebrates (i.e., insects, crustaceans, etc.) and lack a highly methylated genome. In contrast, members of the *Ranavirus*, *Lymphocystivirus*, and *Megalocytivirus* genera infect cold-blooded vertebrates such as fish, amphibians, and reptiles and possess genomes in which approximately 25% of the cytosine residues are methylated by a virus encoded DNA methyltransferase (Willis and Granoff 1980). However, there is at least one ranavirus, Singapore grouper iridovirus (SGIV), that lacks the DNA methyltransferase gene and cannot methylate its DNA (Song et al. 2004).

The division of the family into genera was initially based on biological properties of the viruses (e.g., host range, GC content of the genome, serology, virion morphology, particle size, histopathology, and clinical signs of disease). GC content varies markedly and ranges from 27%–29% (irido- and lymphocystiviruses) to 48%–55% (chlorirido-, rana- and megalocytiviruses) and does not correspond to either the GC content of the host or the methylation status of the virus. Not unexpectedly, codon usage is influenced by the overall GC content, but the basis for the marked difference in GC content among different viral genera is unknown (Schackelton et al. 2006; Eaton et al. 2007; Tsai et al. 2007). Recent analyses of the amino acid sequences of the major capsid protein (MCP) and other viral proteins confirmed these taxonomic divisions and indicated that species within a genus generally shared high levels of identity/similarity. Typically, members of the same viral genus show more than 70% similarity within the major capsid protein (MCP) at the amino acid level, whereas species from different genera show less than 50% similarity (Do et al. 2005a, 2005b).

Although identification of iridovirid genera has been relatively straightforward, identification of individual viral species has proven to be more difficult because of high levels of sequence identity/similarity within the MCP and other highly conserved proteins among members of the same genus. For example, several ranavirus species show greater than 90% amino acid identity within the highly conserved MCP. Thus, differentiation of viral species is based on multiple criteria including viral protein profiles, DNA restriction fragment length polymorphisms (RFLPs), host species infected, clinical signs (i.e., histopathology and gross pathology), and differences in nucleotide and amino acid sequences (Mao et al. 1997; Chinchar and Mao 2000; Chinchar et al. 2005). Unfortunately, the lack of sequence information from many vertebrate and invertebrate iridovirid isolates continues to hamper taxonomic classification and results in a significant number of tentatively assigned and unclassified isolates. Moreover, because of the aforementioned high level of amino acid conservation within the MCP, differentiation of iridovirid species based on serological differences has not proven useful (Hedrick et al. 1992a; Chinchar et al. 2005). To further confound taxonomic classification, identical, or nearly identical, viruses have been given different names reflecting the host species or the geographic regions from which they were isolated.

As the number of iridovirid isolates increases, a change in the way that new viruses are designated may be in order. In the past, multiple isolates of ostensibly the same

viral species were made from different host species and given different names. While some of these may represent novel viral species, others are likely strains or isolates of the same virus. Although the International Committee for the Taxonomy of Viruses (ICTV) does not recognize taxonomic distinctions below the species level, it may be important for working virologists to unambiguously identify clinically or ecologically important isolates in the same way that bacteriologists identify pathogenic strains of *Escherichia coli*, or virologists identify strains of influenza A virus. Based on the latter example, it may be appropriate to utilize a standard nomenclature to designate iridovirid isolates. For example, a novel isolate of *Ambystoma tigrinum virus* would be designated as *Ambystoma tigrinum virus* (*A. tigrinum*/Fort Collins/1/2005) where, following identification of the viral species, the four identifiers within the parentheses indicate the host species from which the isolate was obtained, the location of the isolate, the isolate number, and the year of isolation. As with influenza virus, once the virus has been clearly identified, it could be referred to by a suitable abbreviation such as ATV/FC/1/05. While far from perfect, use of this convention may help resolve the confusion resulting when a given virus species displays a range of clinical symptoms, a broad host range, and wide geographical distribution.

The Viral Genome

Genomic Organization

Because the viral genome is circularly permuted and terminally redundant, no two iridovirid genes consistently occupy the ends of the viral genome. Moreover, gene order within the family is not fixed, and even among members of the same genus, gene order can be quite variable. For example, dot-plot analysis, involving the systematic comparison of nucleotide positions in one genome with nucleotide positions in another genome, revealed that although tiger frog virus (TFV) and ATV displayed considerable co-linearity over large portions of their genomes, two inversions were noted, the largest of which involved an approximately 40-kbp fragment (He et al 2002; Jancovich et al. 2003). As expected, more closely related viruses such as FV3 and TFV, which are considered to be strains of the same species, possess nearly co-linear genomes (Tan et al. 2004), whereas more distantly related ranaviruses such as SGIV and FV3, or red sea bream iridovirus (RSIV) and FV3, which are species from different genera, showed, respectively, little or no conservation of gene order (V.G. Chinchar, unpublished observation). These results suggest that the relative positions of genes within iridovirid genomes are not important determinants of gene expression or virion viability. The marked differences in gene order among various viral species may be a consequence of the high rate of recombination that has been noted previously (Chinchar and Granoff 1986). Furthermore, these findings support earlier observations that iridovirid genes are not spatially clustered by functional or temporal class (McMillan and Kalmakoff 1994; D'Costa et al. 2004; Tan et al. 2004; Lua et al. 2005).

Viral Genes: Identity and Function

Although there is still some disagreement on the exact numbers, based on the genome size, iridovirids contain between roughly 100 (ATV and FV3) and 200 (IIV-6) open reading frames (ORFs) (Tsai et al. 2007; Eaton et al. 2007; see Table 2). Some reports suggest that more than 400 ORFs are encoded by IIV-6, but these include ORFs that overlap each other on the same or different DNA strands and thus likely overestimate the actual number of viral gene products. Consistent with this lower estimate, D'Costa et al. (2004) detected 137 IIV-6 transcripts (38 immediate-early, 34 delayed-early, and 65 late) by Northern blotting. Among the viruses sequenced to date, the functions or presumed functions of about 25%–35% of the putative viral proteins are known or have been inferred by homology to other viral or cellular proteins. Most of the remaining ORFs match putative proteins present in one or more iridovirids, suggesting that they play important roles in iridovirid replication, biogenesis, and survival (Eaton et al. 2007). Viral genes involved in DNA and RNA synthesis, dTTP synthesis, and the evasion of host immune responses have been identified. For example, iridovirids encode their own DNA polymerase, homologs of the two largest subunits of RNA polymerase II, a RAD2-like repair enzyme, a DNA methyltransferase (vertebrate iridovirids only), an RNase III-like protein, helicases, NTPases, and various kinases (reviewed in detail by Williams et al. 2005). Overall, iridovirids contain a common set of viral genes that encode viral structural and catalytic proteins that permit replication in a broad range of cell types (Eaton et al. 2007). However, individual species vary considerably in their content of non-core genes, likely reflecting differences in their respective hosts and survival strategies.

Table 2 Coding potential of iridovirus genomes

Genus	Virus	Kbp ^a	No. genes ^b	%GC	GenBank Acc. No.
<i>Iridovirus</i>	IIV-6	212,482	193	29%	AF303741
<i>Chloriridovirus</i>	IIV-3	191,132	135	48%	DQ643392
<i>Lymphocystivirus</i>	LCDV-1	102,653	107	29%	L63545
	LCDV-C	186,250	160	27%	AY380826
<i>Megalocytivirus</i>	ISKNV	111,362	121	55%	AF371960
	OSGIV	112,636	126	54%	Ay894343
	RBIV	112,080	127	53%	AY532606
<i>Ranavirus</i>	FV3	105,903	97	55%	AY548484
	TFV	105,057	101	55%	AF389451
	ATV	106,332	93	54%	AY150217
	SGIV	140,131	142	49%	AY521625
	GIV	139,793	142	49%	AY666015

^a The value shown represents the unique genome size in kilobase pairs minus the length of the terminal repeat

^b The value shown is an estimate of the total number of nonoverlapping genes encoded by a given virus. It is generally lower than the total number of putative ORFs, which includes putative genes encoded on opposing DNA strands and overlapping genes. The numbers shown are averages based on the estimates of Eaton et al. (2007) and Tsai et al. (2007)

Iridovirid Phylogeny

To date 12 complete genomic sequences, including representatives of each of the five established genera, as well as partial sequences of numerous other isolates, have been determined, and phylogenetic trees based on individual viral protein-coding regions or concatenated sequence sets have been constructed (Jancovich et al. 2003; Tan et al. 2004; Delhon et al. 2006; Kitamura et al. 2006). Although the resulting phylogenies generally confirm the current taxonomy (Fig. 1), representatives of the two genera from invertebrates form what is, essentially, one cluster. Furthermore, while trees similar to those shown in Fig. 1 and elsewhere (Delhon et al. 2006; Tang et al. 2007) indicate that IIV-6 (genus *Iridovirus*) and IIV-3 (genus *Chloriridovirus*) are distantly related, several tentative invertebrate virus species that were presumed to be members of the genus

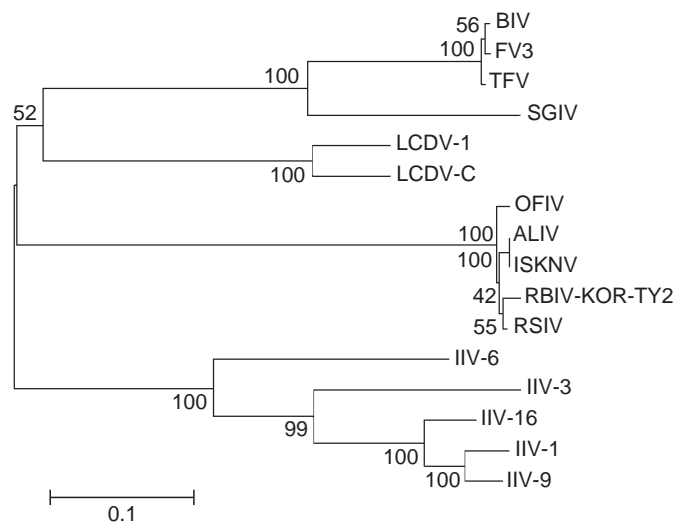

Fig. 1 Iridovirid phylogeny. The inferred amino acid sequences of the MCP of 16 iridovirids representing all five currently recognized genera were aligned using the CLUSTAL W program. Subsequently, a phylogenetic tree was constructed using the Neighbor-Joining algorithm and Poisson correction within MEGA version 3.1 and validated by 1,000 bootstrap repetitions (Kumar et al. 2004). Branch lengths are drawn to scale, and a scale bar is shown. The number at each node indicates bootstrapped percentage values. The sequences used to construct the tree were obtained from the following viruses: genus *Megalocytivirus*—*ISKNV* infectious skin and kidney necrosis virus (AF370008), *ALIV* African lamprey iridovirus (AB109368), *OFIV* olive flounder iridovirus (AY661546), *RSIV* red sea bream iridovirus (AY310918), *RBIV* rock bream iridovirus (AY533035); genus *Ranavirus*—*SGIV* Singapore grouper iridovirus (AF364593), *TFV* tiger frog virus (AY033630), *BIV* Bohle iridovirus (AY187046), *FV3* Frog virus 3 (U36913); genus *Lymphocystivirus*: *LCDV-1* Lymphocystis disease virus (L63545), *LCDV-C* lymphocystis disease virus—China (AAS47819.1); genus *Iridovirus* —*IIV-6* Invertebrate iridescent virus 6 (AAK82135.1), *IIV-16* (AF025775), *IIV-1* (M33542), and *IIV-9* (AF025774); genus *Chloriridovirus*—*IIV-3* (DQ643392)

Iridovirus cluster closer to IIV-3 than to IIV-6. Moreover, the tree shows that iridovirids group into four well-resolved clusters corresponding to the *Ranavirus*, *Megalocytivirus*, *Lymphocystivirus*, and *Iridovirus/Chloriridovirus* genera. However, it is not possible to determine if one genus is descended from another, or if all four genera are derived from a common ancestor. In addition to studies focused solely on iridovirids, several investigators have examined the phylogenetic relationships among ascoviruses, mimiviruses, and four families of nuclear cytoplasmic large DNA-containing viruses (NCLDV), i.e., *Iridoviridae*, *Phycodnaviridae*, *Asfarviridae*, and *Poxviridae*. These analyses suggest that the six families share a common ancestry (Stasiak et al. 2000, 2003; Iyer et al. 2001; Allen et al. 2006). One recent study postulates that iridovirids may be closer to the recently discovered mimiviruses than to other virus families (Allen et al. 2006), but the branching order is far from certain and the authentic phylogeny remains unresolved.

Replication Cycle

Although iridovirids other than FV3 have been examined by several groups, few of these studies have focused on the mechanisms of replication. Consequently, most of what we know about iridovirid biogenesis is derived from studies of FV3, and the assumption, often unstated, is that other members of the family utilize the same general replication strategy as FV3. While this assumption is likely true among members of the genus *Ranavirus*, experience in other viral families suggests that care must be taken when extending strategies utilized in one genus to members of different genera. Nevertheless, this summary will focus primarily on events in FV3-infected cells, but include findings from other iridovirids where appropriate. The main events in iridovirid replication are shown schematically in Fig. 2.

Attachment and Uncoating

Little is known about early events in iridovirid-infected cells. Both naked and enveloped FV3 virions are infectious, although the latter have a higher specific infectivity, likely owing to the presence of specific receptor proteins within the viral envelope (Gendrault et al. 1981; Braunwald et al. 1979). The cellular receptor(s) for FV3 is unknown but is thought to be a ubiquitous cellular molecule since the *in vitro* host range of FV3 is very broad and encompasses mammalian (e.g., HeLa, BHK, and CHO), piscine, amphibian, and reptilian cells (Goorha and Granoff 1979). The *in vivo* host range is certainly far more restricted than the *in vitro* range and likely reflects the inability of the virus to replicate at temperatures above 32°C, and perhaps differences in the availability

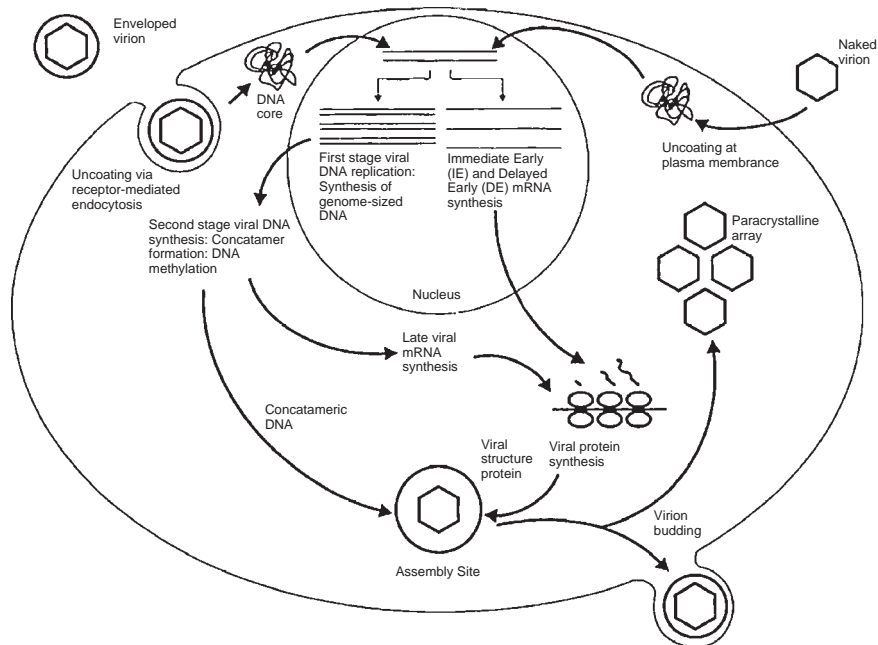

Fig. 2 Iridovirid replication cycle. The life cycle of frog virus 3 (FV3) is illustrated. See text for details. (From Williams et al. 2005, with permission)

or expression of cellular receptors in whole animals, as well as differences in cellular physiology, immune response, etc. Transmission electron micrographic observations suggest that enveloped viruses enter cells via receptor-mediated endocytosis and are uncoated in lysosomes, whereas naked virions uncoat at the plasma membrane (Braunwald et al. 1985). In the latter case, viral DNA cores are released into the cytoplasm following virus–cell membrane interaction and are subsequently transported into the nucleus. Enveloped IIV particles may uncoat singly or in groups within vesicles (Younghusband and Lee 1969; Matheson and Lee 1981), whereas naked particles uncoat within the cytoplasm (Leutenegger 1967; Kelly and Tinsley 1974).

Nuclear Events

Early Gene Transcription

As with other large DNA viruses, iridovirid genes are expressed in a well-regulated temporal cascade involving the sequential expression of immediate-early (IE), delayed-early (DE), and late viral messages (Willis and Granoff 1978; D’Costa

et al. 2001, 2004). However, unlike herpesviruses and poxviruses, where transcription is confined to nuclear or cytoplasmic sites, respectively, FV3 IE transcription takes place in the nucleus, whereas late viral message synthesis likely occurs in the cytoplasm (Goorha et al. 1978; Willis and Granoff 1978). Host RNA polymerase II (Pol II) is thought to be responsible for the synthesis of IE messages using input viral genomes as template (Goorha 1981). Support for the role of host Pol II is based on the observation that viral transcription is blocked by treatment of infected cells with α -amanitin, a potent inhibitor of Pol II, but is not blocked in α -amanitin-resistant cells. In marked contrast to herpesviruses, where transfection of naked viral DNA into permissive cells results in a productive infection, naked iridovirid DNA cannot be transcribed and therefore is not infectious. However, introduction of FV3 DNA into cells that were previously treated with UV-inactivated FV3 resulted in the successful transcription of IE viral mRNA and a productive virus infection. The simplest interpretation of this phenomenon is that IE transcription requires the presence of one or more virion-associated, transcriptional transactivators (VATT) in addition to host Pol II and that these are supplied by UV- (but not heat-) inactivated FV3 (Willis and Granoff 1985; Willis et al. 1990a, 1990b). This phenomenon is not unique to FV3 since nongenetic reactivation has also been observed with IIV-6 (Cerutti et al. 1989). At this time, neither the identity nor the precise mode of action of the VATT are known. It is not clear if VATT modifies the viral DNA template or if it interacts with Pol II to initiate transcription. Following synthesis of viral IE transcripts and their subsequent translation, one or more IE proteins (referred to as virus-induced transcriptional transactivators, VITT) are required for expression of DE and late viral transcripts. VITTs are thought to be required for transcription of the highly methylated viral genome, and a factor present in cells productively infected with FV3 has been shown to facilitate transcription of a methylated adenovirus promoter (Willis et al. 1989, 1990a). Collectively, IE and DE transcripts prepare the way for virion formation since IE transcripts are thought to encode regulatory proteins, whereas DE messages likely encode catalytic proteins, such as the viral DNA polymerase (Lua et al. 2005). While this view is generally correct, recent work involving an antisense morpholino oligonucleotide (asMO) targeted against an FV3 18-kDa IE protein suggests that not all IE proteins are key viral regulators. In this study, prior treatment of infected cells with the asMO reduced synthesis of the 18kDa protein by roughly 80% without affecting the expression of other viral proteins or reducing virus yields (Sample et al. 2007).

First-Stage Viral DNA Replication

Following synthesis of the viral DNA polymerase and its subsequent translocation into the nucleus, viral DNA replication commences within the nucleus and results in the synthesis of genome-size to twice genome-size DNA molecules (Goorha 1982). As with other large DNA viruses, viral DNA synthesis is sensitive to inhibition by phosphonoacetic acid (PAA), an inhibitor of viral DNA polymerases, and aphidicolin, an inhibitor of eukaryotic DNA polymerase α (Chinchar and

Granoff 1984). Inhibition of viral DNA synthesis results in a marked inhibition of late viral gene expression, suggesting that late gene expression is dependent upon viral DNA synthesis (Chinchar and Granoff 1984, 1986). It is not clear whether the need for viral DNA synthesis reflects the requirement for newly synthesized viral templates or the requirement for late transcription to take place in the cytoplasm using a viral-encoded RNA polymerase. Genetic evidence suggests that at least one viral protein, probably the viral DNA polymerase, is required for first-stage viral DNA replication (Goorha et al. 1981; Chinchar and Granoff 1986). Newly synthesized viral DNA molecules are subsequently transported to the cytoplasm where they serve as templates for the formation of concatameric DNA, i.e., second-stage DNA synthesis.

Cytoplasmic Events

Viral DNA Methylation

Following transport of newly synthesized viral DNA to the cytoplasm, cytosine residues within CpG motifs are methylated by a virus-encoded DNA methyltransferase (DMTase; Willis et al. 1984; Kaur et al. 1995). Ultimately, 20%–25% of the cytosine residues are methylated, resulting in the highest level of genome methylation known among animal viruses. Inhibition of methylation by treatment of infected cells with 5-azacytidine lowered virus yields by 100-fold but did not reduce viral RNA or protein synthesis, suggesting that methylation is not necessary for viral gene expression (Goorha et al. 1984). However, treatment with 5-azacytidine reduced the size of replicating viral DNA (measured under denaturing conditions) indicating that undermethylated viral DNA was susceptible to DNase-mediated degradation. These and other results suggest that the viral DMTase may be part of a restriction modification system, and that methylation protects viral DNA from endonucleolytic attack (Essani et al. 1987). While this interpretation is consistent with the above data, it is also possible that methylation of the viral genome may play a role in blocking the induction of pro-inflammatory cytokines following interaction of unmethylated viral DNA with Toll-like receptor 9 (TLR 9). In mammalian systems, interaction of unmethylated bacterial or viral DNA with TLR 9 results in the activation of NF- κ B and the induction of type I interferons and inflammatory cytokines (Bauer et al. 2001; Boehme and Compton 2004). Whether unmethylated FV3 also triggers an inflammatory response remains to be seen.

Second-Stage Viral DNA Replication: Concatamer Formation

In addition to methylation, viral DNA undergoes a second round of DNA synthesis, which results in the formation of large, concatameric structures that are more than ten times larger than genome-sized units (Goorha 1982). Genetic evidence

suggests that a second viral protein, distinct from the viral DNA polymerase, is required for concatamer formation (Goorha and Dixit 1984). It is not known whether this protein plays a direct or indirect role in concatamer formation, e.g., by facilitating the transport of viral DNA from nucleus to the cytoplasm or by actively catalyzing the formation of concatamers. In addition, although concatameric viral DNA is likely present in cytoplasmic viral assembly sites (AS), it is not clear whether concatamers are constructed in preformed AS, or whether AS develop around sites of concatamer synthesis (Chinchar et al. 1984).

Late Viral Gene Transcription

The identification of viral homologs of the two largest subunits of host Pol II (designated vPol-II α and -II β) in all iridovirids sequenced to date strongly suggests that late in infection viral transcription is catalyzed by a virus-modified, or virus-encoded, DNA-dependent RNA polymerase (Williams et al. 2005; Eaton et al. 2007). Our current working model postulates that IE transcription takes place in the nucleus in reactions catalyzed by host Pol II, whereas late viral transcription occurs in the cytoplasm, perhaps within viral AS, and is catalyzed by vPol II. It is also possible that late in infection vPol II translocates to the nucleus and directs transcription of IE mRNAs. Experimental support for the role of vPol II in late viral RNA synthesis has recently been obtained. Inhibition of vPol II formation, using an asMO targeted to vPol II α , resulted in a marked reduction in the synthesis of late viral gene products and viral titers, but did not affect early protein synthesis (Sample et al. 2007). These results are consistent with the hypothesis that vPol II α is an integral part of the RNA polymerase and is responsible for late viral mRNA synthesis. However, it remains to be determined if the viral RNA polymerase is entirely virus-encoded or if it is a chimera composed of host and viral components.

Viral Protein Synthesis

Late viral proteins are thought to encode structural elements of the virion and other virion-associated proteins. Aside from the MCP, which makes up the bulk of the viral capsid, the identities of other virion-associated proteins are largely unknown. Approximately 30 proteins are virion-associated, but whether they serve structural roles and are true capsid proteins, or whether they are virion-associated regulatory or catalytic proteins, is not known (Willis et al. 1985). Interestingly, complementation analysis of FV3 temperature-sensitive (ts) mutants indicates that at least 12 viral genes are involved in virion assembly (Chinchar and Granoff 1986). Defects in any one of these 12 genes had no apparent effect on the synthesis of viral protein, RNA or DNA, or assembly site formation, but reduced the yield of infectious virions by approximately 1,000-fold. Unfortunately, it is not known whether noninfectious virus particles are formed, or whether the specific ts defects block formation of recognizable virion structures. Early work suggested that late viral

protein synthesis is translationally regulated and requires a viral-encoded function, perhaps analogous to a virus-encoded translational initiation factor (Raghow and Granoff 1983). While the biochemical data supporting the existence of a translational transactivator appear solid, recent studies have revealed that *in vitro* synthesized early and late viral transcripts were translated with roughly equal efficiency in cell-free protein synthesizing systems, suggesting that a virus-induced factor was not needed for the *in vitro* translation of late viral transcripts (Mao et al. 1996; J. Mao and V.G. Chinchar, unpublished observations). This discrepancy has yet to be resolved.

Viral Assembly Sites and Virion Formation

Virion morphogenesis takes place in morphologically distinct areas of the cytoplasm termed viral assembly sites (AS). When visualized by electron microscopy (Fig. 3A), AS appear as clear regions within the cytoplasm that are devoid of large cellular organelles and are surrounded by mitochondria and intermediate filaments (Murti et al. 1988; Murti and Goorha 1989, 1990; Huang et al. 2007). While the position of the mitochondria may reflect their exclusion from the enlarging AS, intermediate filaments are thought to play an active role by anchoring the AS within the cytoplasm and excluding cellular elements that might interfere with virion morphogenesis (Murti et al. 1988). Alternatively, as suggested for hepatitis B virus, and African swine fever virus (ASFV), the clustering of mitochondria may reflect the need for

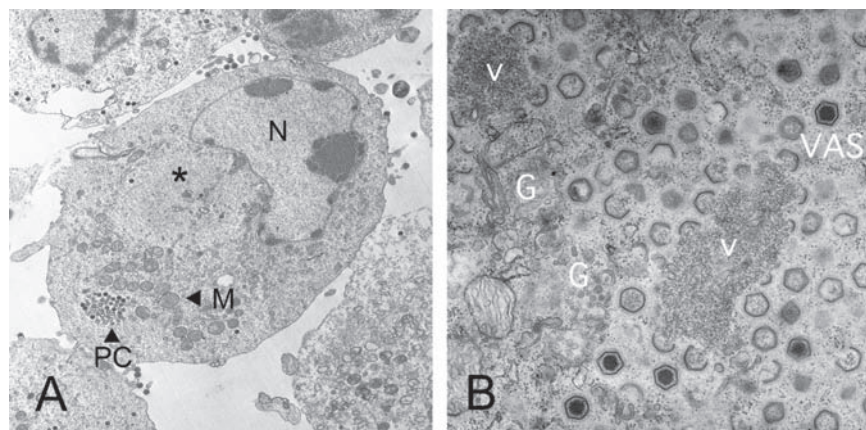

Fig. 3 Transmission electron micrographs of iridovirid-infected cells. **a** A FV3-infected fathead minnow cell displaying a nucleus (*N*) showing chromatin condensation and margination, a well-formed, electrolucent viral assembly site (*) containing a few viral particles, mitochondria (*M*), and a paracrystalline array of newly assembled virions (*PC*) are shown. (From Sample et al. 2007, with permission). **b** An enlargement of a viral assembly site (*VAS*) within an LCDV-infected cell from the dermis of a Japanese flounder. Viroplasm (*v*), Golgi (*G*) are identified. The *VAS* contains both full and empty particles as well as several incomplete particles

high levels of ATP in virion assembly (Kim et al. 2007; Netherton et al., 2007). Feulgen staining and immunofluorescent staining with polyclonal mouse anti-FV3 serum or monoclonal antibodies targeted to specific viral proteins confirmed that AS contain DNA and viral proteins (Chinchar et al. 1984). Full and empty viral capsids, along with variable numbers of intermediate forms, are readily observed in iridovirid-infected cells (Fig. 3A,B). Elongated linear, bent, and circular structures (referred to as atypical elements) are sometimes seen, but it is not known if these are intermediates in virion morphogenesis or aberrant products of virus assembly (Huang et al. 2005; Sample et al. 2007). Transmission electron microscopy suggests that virion assembly occurs adjacent to electron dense follicular structures (Huang and Zhang 2007; Fig. 3B). Studies with African swine fever virus (ASFV), a large DNA virus with structural similarity to FV3, may shed light on iridovirid virion morphogenesis. Here virion formation is thought to begin by recruiting endoplasmic reticulum cisternae that give rise to viral membranes. These membranes develop into icosahedral structures through the progressive assembly of capsid proteins. Concomitantly, the core shell is formed under the inner envelope and viral DNA and nucleoproteins are packaged (Epifano et al. 2006). Currently, it is unclear whether iridovirid capsid proteins associate with cellular membranes, as is seen with ASFV, and serve as intermediates in iridovirid assembly. Furthermore, recent work with ASFV indicates that viral assembly sites resemble cellular aggresomes. Aggresomes are perinuclear structures, enclosed within a vimentin cage, that recruit cellular chaperones and proteases in response to high levels of misfolded or unassembled proteins (Heath et al. 2001). It is possible that aggresome formation, a cellular response for dealing with potentially toxic misfolded proteins, has been exploited by ASFV and iridovirids as a means of generating a cytoskeletal scaffold for concentrating structural proteins at the sites of virus assembly (Wileman 2006).

Virions are thought to package viral DNA by a “headful” mechanism in which a unit length of DNA plus an additional 5%–50% of the genome, depending upon the specific virus, is encapsidated. This method of packaging results in a DNA molecule that is circularly permuted and terminally redundant (Goorha and Murti 1982). Following their formation, virions accumulate in paracrystalline arrays within the cytoplasm or are transported to the plasma membrane where they acquire an envelop by budding. However, in cells infected by FV3, more than 90% of virions remain cell-associated.

Experiments using asMOs and short, interfering RNAs (siRNAs) targeted to the MCP illustrate the important role that the MCP plays in virion morphogenesis. Xie et al. (2005) showed that treatment of FHM cells with siRNAs targeted to the MCP transcript of TFV, a strain of FV3, resulted in marked reductions in CPE, virus yield, and the assembly of particles. We recently confirmed and extended these findings using an asMO targeted against the FV3 MCP. FHM cells pretreated with an anti-MCP asMO and infected 24 h later with FV3 showed an 80% reduction in MCP synthesis and a 90% drop in virus titer. Moreover, transmission electron microscopy showed that circular, bent, and tubular atypical elements were the predominant products detected within the AS of cells treated with an asMO targeted to the MCP (Sample et al. 2007). Interestingly, treatment of cells with an asMO

targeted to the vPol-II α transcript blocked the synthesis of the MCP protein and other late proteins, but did not result in the appearance of atypical elements, suggesting that their formation requires the presence of one or more yet to be identified late proteins along with the absence of the MCP.

Viral Effects on Host Cell Function

Inhibition of Host Cell Macromolecular Synthesis

Iridovirid infection has a dramatic inhibitory effect on cellular protein, RNA, and DNA synthesis (Raghow and Granoff 1979; Cerutti and Devauchelle 1980; Chinchar and Dholakia 1989). Interestingly, host macromolecular synthesis is blocked following productive infection, or treatment with heat-inactivated or UV-inactivated virus, indicating that the inhibitory component(s) is possibly a viral structural protein rather than a newly synthesized viral gene product. Alternatively, the interaction of virions with one or more cellular receptors might trigger shutoff through an unidentified signaling pathway. The molecular basis for translational shutoff and the selective synthesis of viral proteins is not known but likely reflects a combination of processes including the additive effects of (i) host message degradation (Chinchar and Yu 1992), (ii) the synthesis of large amounts of translationally efficient viral messages (Chinchar and Yu 1990), (iii) a global block in translation triggered by the PKR (a protein kinase activated by dsRNA) - mediated phosphorylation and subsequent inactivation of eukaryotic translational initiation factor 2 α (eIF-2 α) (Chinchar and Dholakia 1987), and (iv) the presence of a viral homolog of eIF-2 α (designated vIF-2 α) that is thought to act as a pseudo-substrate and prevent eIF-2 α phosphorylation by binding PKR (Essbauer et al. 2001; Jancovich et al. 2003). The block to host DNA synthesis is thought to be due to the prior inhibition of cellular protein and RNA synthesis and not to a direct effect on cellular DNA replication, whereas nothing is known about the molecular basis for transcriptional inhibition.

By analogy to the vaccinia virus K3L protein, the ranavirus vIF-2 α gene product is thought to maintain protein synthesis in virus-infected cells by binding PKR and blocking its interaction with eIF-2 α (Beattie et al. 1991; Kawagishi-Kobayashi et al. 1997). However, in contrast to other ranaviruses, some strains of FV3 contain a truncated version of vIF-2 α that likely resulted from an upstream deletion that apparently fused the first 11 amino acids from a small upstream ORF to the C-terminal 65 amino acids of vIF-2 α . Contrary to expectations, FV3 strains bearing the truncated vIF-2 α homolog efficiently synthesized their own proteins and rapidly shut off host cell translation (Chinchar and Dholakia 1989; Tan et al. 2004). This was not due to residual activity within the truncated protein since homology to K3L and eukaryotic eIF-2 α resides in the N-terminal 100 amino acids that were lost. Since other ranaviruses contain full-length copies of vIF-2 α , it is not clear whether vIF-2 α was absent in the original FV3 isolate, or whether it has been lost following

repeated passages in cultured cells over the last 40 years. Perhaps relevant to this situation is the observation that serial, low multiplicity passages of *Autographa californica* nucleopolyhedrovirus resulted in the selection of viable viruses with deletions or insertions in the DNA (Miller 1996). While the absence of a full-length version of vIF-2 α in FV3 casts doubt on the role of this protein in maintaining viral protein synthesis late in infection, it is possible that FV3 may contain a second protein that acts upstream of vIF-2 α . Such is the case in vaccinia virus, where the E3L protein binds dsRNA and blocks PKR activation (Langland and Jacobs 2002).

Apart from its role in protein synthesis, vIF-2 α may also influence virulence. FV3 replicates efficiently *in vitro*, but is markedly less virulent *in vivo* than *Rana catesbeiana* virus Z (RCV-Z), a ranavirus that possesses a full-length vIF-2 α . Thus, infection of bullfrog (*R. catesbeiana*) tadpoles with RCV-Z proved lethal, whereas infection with FV3 containing a truncated vIF-2 α gene resulted in little or no mortality (Majji et al. 2006). Moreover, prior infection with FV3 protected tadpoles from subsequent lethal challenge with RCV-Z (Majji et al. 2006). Whether vIF-2 α plays an additional role in viral biogenesis is not known. However, recent evidence that PKR is involved in NF- κ B activation and the induction of pro-inflammatory cytokines (Tan and Katze 1999; Williams 1999) suggests that if vIF-2 α is able to block this pathway by binding PKR, then the onset of an immune response might be delayed and virus yields enhanced. While this immune evasion pathway is unlikely to be important following high multiplicity, synchronous infection of cultured cells, it could have important consequences for infections *in vivo* that may be initiated with low levels of virus that require multiple rounds of replication prior to the development of clinical disease.

Apoptosis

Aside from the marked inhibition of cellular synthetic functions, iridovirid infection also results in the induction of apoptosis. As with CPE, apoptosis is triggered following either productive infection or treatment with heat-inactivated or UV-inactivated virus or a soluble virion extract (Essbauer and Ahne 2002; Chinchar et al. 2003; Hu et al. 2004; Imajoh et al. 2004; Paul et al. 2007; Huang et al. 2007a). In FV3-infected cells, apoptosis begins 6–8 h postinfection (p.i.) and is characterized by DNA fragmentation, chromatin condensation, apoptotic body formation, and the appearance of phosphatidylserine on the outer leaflet of the cellular membrane. Iridovirus-induced apoptosis is likely mediated by cellular caspases since Z-VAD-FMK, a pan-caspase inhibitor, blocks apoptosis (Chinchar et al. 2003; Paul et al. 2007). In addition, Huang et al. (2007a) reported mitochondrial fragmentation, the activation of caspases 3 and 9, and an increase in intracellular Ca⁺² in RGV-infected cells. Although it is not known whether apoptosis is a consequence of PKR activation, translational shutoff, or occurs independently of those events, Paul et al. (2007) demonstrated that the amount of soluble virion extract required to induce apoptosis was 1,000-fold lower than the dose required to shutdown protein synthesis. This result suggests that in the IIV-6 system translation shutoff may not be required to

induce apoptosis. Furthermore, IIV-6 encodes a protein with homology to the baculovirus inhibitor of apoptosis protein (IAP), and it is likely that other iridovirids encode proteins that delay the onset of apoptosis. It may be advantageous for iridovirids to seek a balance between inducing and inhibiting apoptosis. In this view, if apoptosis occurs too soon, virus yields will be depressed, but if apoptosis is unduly delayed, necrotic cells may trigger a much more robust pro-inflammatory response than that induced by apoptotic cells.

Viral Immune Evasion, Host Range, and Virulence Proteins

Based on analogy to poxviruses and herpesviruses, it is likely that iridovirids encode multiple proteins that modulate host immune responses (Alcami and Koszinski 2000; Tortorella et al. 2000; Johnston and McFadden 2003). To date, several proteins that potentially modulate cellular immune responses to infection have been identified, including the aforementioned vIF-2 α , a CARD (caspase recruitment domain)-containing protein (designated vCARD), an hydroxysteroid dehydrogenase (vHSD), a viral homolog of the tumor necrosis factor receptor (vTNFR), the aforementioned IAP, and several ORFs encoding putative proteins containing immunoglobulin- or MHC-like domains (Jakob et al. 2001; Jancovich et al. 2003; Essbauer et al. 2004; Song et al. 2004; Tan et al. 2004). Although vIF-2 α may play a role in maintaining viral protein synthesis in infected cells, recent data suggest that it might also be involved in blocking induction of an inflammatory response (Tan and Katze 1999; Williams 1999; Gil et al. 2004). Likewise, since DEATH domains, DEATH effector domains, CARDs, and pyrin motifs are thought to mediate inflammatory responses via protein–protein interactions, vCARD may block activation of pro-inflammatory or apoptotic responses, or, conversely, activate a pathway that is dependent on CARD–CARD interactions (Bouchier-Hayes and Martin 2002; Johnson and Gale 2006; Werts et al. 2006; Holm et al. 2007). Although its mechanism of action is different, the viral homolog of the TNFR may also block activation of proinflammatory genes by binding TNF and preventing signaling through the authentic TNF receptor (Essbauer et al. 2004). Similar to its vaccinia virus homolog, vHSD may play a role in modulating steroid biosynthesis and thereby impair immunity following *in vivo* infections (Moore and Smith 1992; Reading et al. 2003). Among ranaviruses, overexpression of the viral homolog of HSD suppressed the cytopathic effect, suggesting that it may play a role *in vitro* as well as *in vivo* (Sun et al. 2006). Inasmuch as the current catalog of potential iridovirid immune evasion proteins is short, the relatively large number of poxvirus proteins involved in immune evasion, virulence, and host range suggests that additional iridovirus proteins that affect these functions await discovery. Moreover, we anticipate that as more is revealed about the immune systems of iridovirid hosts, additional immune evasion, virulence, and host range modifiers will be identified by homology to their cellular counterparts.

In addition to putative immune evasion proteins, iridovirids and other large DNA viruses such as ASFV, poxviruses, and herpesviruses encode a number of proteins

(dUTPase, ribonucleotide reductase, thymidylate synthase) with marked homology to cellular genes involved in dTTP synthesis (Oliveros et al. 1999; Langelier et al. 2002; Lembo et al. 2004; Glaser et al. 2006; Zhao et al. 2007; Zhang et al. 2007). Inclusion of these enzymes within the viral proteome is thought to ensure sufficient quantities of dNTPs for viral nucleic acid synthesis and to lessen the chances of misincorporating uracil into viral DNA (Oliveros et al. 1999; Zhang et al. 2007). Moreover, these enzymes likely play roles in determining host range. For example, Oliveros et al. (1999) found that dUTPase was not required for replication in dividing Vero cells, but was needed for ASFV replication in swine macrophages. Among ranaviruses, overexpression of dUTPase did not enhance the replication of RGV in dividing EPC cells, an established fish cell line (Zhao et al. 2007).

Host Immune Response

Although there is little specific information about the host immune response to iridovirid infection, both humoral and cell-mediated immunity likely play roles in the prevention of, and recovery from, virus infection. For example, *Xenopus* mount effective B cell and T cell responses against FV3 infection (Morales and Robert 2007; Maniero et al. 2006), and antibodies targeted to other ranaviruses can be detected in infected frogs (Zupanovic et al. 1998a). Moreover, vaccination is effective in preventing disease due to RSIV infection (Caipang et al. 2006a, 2006b), and prior infection of bullfrog tadpoles with relatively avirulent FV3 protects against subsequent challenge with virulent RCV-Z (Majji et al. 2006). At the molecular level, ISKNV infection has been shown to induce in mandarin fish a variety of putative antiviral proteins, including homologs of a VHSV-induced protein, Gig2, viperin, Mx, CC chemokines, the immunoglobulin heavy chain etc. (He et al. 2006). As the immune systems of lower vertebrates become better understood, it is likely that their role in protecting fish, amphibians, and reptiles from iridovirid infections will become clearer and utilized to develop more effective vaccination strategies.

Biology and Ecology of Iridovirid Infections

FV3 and Other Amphibian Ranaviruses

FV3 was serendipitously isolated more than 40 years ago in the course of an attempt to develop cell lines that would support the growth of Lucke herpesvirus. Granoff et al. (1966) observed that cell monolayers prepared from the kidneys of normal and tumor-bearing frogs (*R. pipiens*) spontaneously underwent lysis. Analysis of the resulting infectious agents (designated frog virus-1, -2, -3, etc.) showed them to be large cytoplasmic DNA viruses with icosahedral symmetry.

While these and other similar viruses were likely different isolates of the same virus species, the isolate designated FV3 became the focus of further study because of its putative association with renal adenocarcinoma (Clark et al 1968; Granoff et al. 1966). Subsequent analysis indicated that FV3 played no part in tumor formation, but the virus continued to be studied and is now the best characterized iridovirid and the type species of the genus *Ranavirus* (Goorha and Granoff 1979).

The isolation of FV3 from ostensibly healthy anurans suggested that it was a pathogen of low virulence. This inference was confirmed early on by Tweedel and Granoff (1968) who showed that embryos and tadpoles were killed by injection with as little as 900 PFU of infectious virus, whereas adult frogs (*R. pipiens*) survived injection of 10^6 PFU per animal. These results were recently confirmed in a *Xenopus* model by Robert and his co-workers, who showed that tadpoles are relatively sensitive to infection by FV3, whereas adults mount an effective immune response and successfully resist infection unless their immune defenses are compromised by sublethal doses of γ -irradiation or depletion of CD8⁺ T cells (Gantress et al. 2003; Robert et al. 2005). Moreover, FV3 displays a strong tropism for the proximal tubular epithelium of the kidney, but rarely disseminates beyond that organ in immunocompetent animals. Recently, Maniero et al. (2006) showed that *Xenopus* develop antibodies to FV3 that neutralize the virus in vitro and provide partial protection to susceptible larvae, whereas Morales and Robert (2007) found that protection also correlated with the expansion of CD8⁺ cells. Collectively, these results suggest that both B cell (humoral) and T cell (cell-mediated) responses are critical for viral clearance and protection from disease.

Following the initial isolation of FV3 from North American frogs, numerous other isolations of FV3-like viruses were made in North America (Mao et al. 1999; Green et al. 2002; Greer et al. 2005; Miller et al. 2007), the United Kingdom (Cunningham et al. 1996), China (Zhang et al. 2001, 2006), Thailand (Kanchanakhan 1998), and South America (Zupanovic et al 1998b; Galli et al. 2006; Fox et al. 2006). In some cases, e.g., tadpole edema virus (TEV), Rana United Kingdom (RUK) virus, and Bufo United Kingdom (BUK) virus, viral protein profiles, RFLP analysis, and sequence analysis of the MCP support the notion that these are isolates of FV3 and not distinct viral species (Hyatt et al. 2000). However, in other cases, e.g., BIV and seven recent isolates from South America, RFLP profiles differed markedly from FV3 and are consistent with their classification as separate species or tentative species. Furthermore, unlike the early frog virus isolates that originated from ostensibly healthy adult animals, many of the recent isolates came from tadpoles or frogs that were patently diseased. Although previously considered relatively benign, it is now apparent that FV3-like viruses are capable of causing fatal disease in amphibian larvae and adults. In some cases, disease occurred among farmed frogs, suggesting that stress due to overcrowding may have triggered immune suppression and contributed to clinical disease (Kanchanakhan 1998; Zhang et al. 2001). These results are consistent with findings in the FV3/*Xenopus* model described above wherein the outcome of infection depended upon the degree of immunosuppression (Robert et al. 2005). Reports of ranavirus disease in other species, including reptiles (Chen et al. 1999; Hyatt et al. 2002; De Voe et al. 2004;

Marschang et al. 2005; Allender et al. 2006; Johnson et al. 2007) are becoming increasingly common, but the causative agents have yet to be fully characterized.

While it is clear from experimental transmission studies that larvae and immunocompromised adults are more susceptible to infection than healthy adult frogs, the ways in which FV3 is transmitted and maintained in wild populations are less clear. Recent studies by Pearman et al. (2004, 2005) and Harp and Petranka (2006) examined various aspects of the ecology of FV3 and FV3-like viruses. Pearman et al. (2004, 2005) found that FV3 was pathogenic for *Rana latastei* and that susceptibility to FV3 infection varied among geographically separated populations that differed in genetic diversity. In addition, they suggested that mortality depended on contact between infected and uninfected individuals and was influenced by the concentration of the virus, cannibalism, and necrophagy. Consistent with those results, Harp and Petranka (2006) found that ranavirus was transmitted to healthy *R. sylvatica* tadpoles by scavenging of infected carcasses and by exposure to water containing infected animals or carcasses.

Ambystoma Tigrinum Virus

Whereas outbreaks of FV3-like disease have been detected worldwide, clinical disease triggered by *Ambystoma tigrinum virus* (ATV) has been seen, with only one non-natural exception, in ambystoid salamanders in western North America. ATV was initially isolated from salamanders (*A. tigrinum stebbensi*) in southern Arizona, and related viral strains were subsequently isolated in Colorado, Utah, North Dakota, Saskatchewan, and Manitoba (Jancovich et al 1997; Bollinger et al. 1999; Docherty et al. 2003). Along its extensive north–south range, ATV isolates are similar, although isolates can be differentiated by the presence of point mutations within the MCP gene, RFLP profiles, and the presence or absence of one or more copies of a 16-bp repeat within the ORF 50R/51L intergenic region (Jancovich et al. 2005). The only isolate east of the Mississippi River was made in the axolotl colony at Indiana University following introduction of wild salamanders from Colorado and is genetically similar to ATV isolates from that state (Davidson et al. 2003).

In contrast to FV3 infections, where mortality is more common in larvae than adults, both larval and adult salamanders succumb to ATV infection, and mortality in affected ponds often exceeds 90% (Jancovich et al 1997; Bollinger et al. 1999). Temperature influences the extent of mortality and time to death as most salamanders infected at 26°C survive, whereas those infected at 18°C succumb to infection (Rojas et al. 2005). Clinical disease is accompanied by marked necrosis and hemorrhage within internal organs (spleen, liver, kidney, gastrointestinal tract), skin polyps, skin sloughing, and extrusion of a thick discharge from the vent. Populations rebound in affected ponds, but it is not clear whether this reflects the presence of a few surviving immune animals, or recolonization by naïve animals. Experimental attempts to determine the host range of ATV demonstrated that various salamander species (*Ambystoma graciale*, *A. californiense*, *Notophthalmus viridescens*) are susceptible to infection, but bullfrogs (*R. catesbeiana*) and fish (*Gambusia affinis*, *Lepomis cyanellus*, *Oncorhynchus mykiss*) are resistant to infection (Jancovich

Family *Iridoviridae*: Poor Viral Relations No longer

et al. 2001; Picco et al. 2007). Recently, ATV has been shown to infect wood frogs (*R. sylvatica*) and leopard frogs (*R. pipiens*) although with reduced efficiency and lower virulence, suggesting that its host range may be larger than originally thought (Schock et al. 2008). Despite this intriguing result, the role of anurans and possibly fish in the ecology of ATV infections is unknown. It remains to be determined whether sympatric fish and frog species serve as reservoirs for ATV following the die-off of susceptible salamander populations, or whether sublethally infected metamorphs serve as an intraspecific reservoir and reintroduce the virus into uninfected larval populations (Brunner et al. 2004). Brunner et al. (2007) showed that ATV is effectively transmitted between animals directly by biting, cannibalism, necrophagy or mere physical contact, and indirectly through water and fomites. Moreover, larval salamanders are capable of transmitting virus to naïve animals soon after infection and their infectivity increases with time. Infection rates increase with viral dose and were affected by clutch identity and life stages. Surprisingly, metamorphs were less likely to be infected than larvae, but once infected were more likely to die (Brunner et al. 2005). ATV remains viable in moist soil for several days, but loses infectivity rapidly upon drying. The basis for the apparent sudden emergence of ATV in western North America is not known, but phylogenetic analysis and the marked virulence seen in infected larval and adult salamanders suggests that ATV recently arose from a fish ranavirus that jumped species and now infects salamanders (Jancovich et al. 2005). Moreover, human introduction of ATV through the bait trade has likely contributed to disease emergence (Storfer et al. 2007).

EHNV and Other Australian Ranaviruses

The first report of a ranavirus infecting fish was from Australia. The virus, epizootic hematopoietic necrosis virus (EHNV), was isolated from wild redfin perch (*Perca fluviatilis*) (Langdon et al. 1986) and is unique to Australia. EHNV was the cause of spectacular epizootic mortalities in redfin perch and recurrent epizootics in farmed rainbow trout (*Oncorhynchus mykiss*) (Langdon and Humphrey 1987; Whittington et al. 1994). The host range of the virus now includes recreational fish (Whittington et al. 1996) and the associated clinical disease (epizootic hematopoietic necrosis, EHN) is listed by the Office International Epizooties (OIE) as the cause of significant finfish losses at the zonal/regional level. Furthermore, EHNV has the potential for international spread via live animals or fomites (Office International des Epizooties 2006). Clinically similar systemic necrotizing syndromes have been reported in farmed catfish (*Ictalurus melas*) in France (Pozet et al. 1992), sheatfish (*Silurus glanis*) in Germany (Ahne et al. 1989), turbot (*Scophthalmus maximus*) in Denmark (Bloch and Larson 1993) and other fish species in Europe (Ariel et al. 1999; Tapiovaara et al. 1998), but they appear to be caused by viruses distinct from EHNV (Ahne et al. 1998).

EHNV causes marked mortality in redfin perch and may kill greater than 90% of infected fish (Pierce et al. 1991). Typically fingerling and juvenile fish are affected, but in areas in which EHNV has been newly introduced, adults are also

susceptible (Langdon and Humphrey 1987; Langdon et al. 1986). Natural epizootics are frequently reported in summer when large numbers of presumably nonimmune young fish are present and school in warm shallow waters. EHN is also reported in rainbow trout where the mortality rates are lower and the disease is generally difficult to identify. Outbreaks of the disease appear to be related to poor husbandry (Whittington and Reddacliff 1995).

While numerous amphibian iridovirids have been described worldwide, only two have been identified within Australia. The first was Bohle iridovirus (BIV), which was isolated from a native Australian frog (*Limnodynastes ornatus*) in Northern Queensland (Speare and Smith 1992) and was also shown to be highly pathogenic for barramundi (*Lates calcarifer*), a commercially and recreationally important fish species, following experimental infection (Moody and Owens 1994). Surprisingly, BIV has not been isolated from natural epizootics involving either frogs or fish and has only been isolated from tadpoles taken from the wild and allowed to metamorphose in captivity. A PCR assay for diagnosis of BIV infection has been developed (Pallister et al. 2007) and the putative promoter regions of three genes, including the MCP gene, have been identified (Pallister et al. 2005). A second ranavirus, Wamena virus (WV), was isolated from illegally imported juvenile green pythons (*Chondropython viridis*) and may not be native to Australia (Hyatt et al. 2002). Whereas EHN and BIV are recognized by the ICTV as distinct viral species within the genus *Ranavirus* (Chinchar et al. 2005), WV represents a tentative ranavirus species based on comparison of the MCP and thymidine kinase sequences, dot blot analysis, antigen capture ELISA, and RFLP profiles (Hyatt et al. 2002; Coupar et al. 2005; Hyatt and Whittington 2005).

Experimental infections of cane toad (*Bufo marinus*) tadpoles with BIV led to mortality rates of up to 100% (Hyatt et al. 1998). Clinical signs following experimental infection of tadpoles with BIV include wasting and behavioral changes, i.e., tadpoles frequently lay on the bottom of the tank, often on their sides with their tails curved. Upon stimulation, they swam weakly and erratically in a forward whirling movement. In general, deaths begin about day 5, and peak at 7–8 days p.i. Following both EHN and BIV infection, death is most likely due to the degeneration of hematopoietic cells and damage to the vascular endothelium. Examination of infected tadpoles revealed a systemic infection primarily affecting the major hematopoietic organs, i.e., the kidney, liver, and spleen (Hyatt et al. 1998). In the kidneys, acute hematopoietic necrosis is present, varying from individual infected cells to extensive areas of necrosis (Fig. 4A,B). Infected cells contain characteristic

Fig. 4 Histopathological changes within BIV-infected cells. **a** Light micrograph of a kidney from a *B. marinus* tadpole infected with BIV showing extensive necrosis (*n*) particularly within interstitial tissue. Glomerulus (*g*); tubules (*t*); interstitial tissue (*it*), which is the site of hematopoietic cells; melanin pigment (*p*); muscle of the base tail (*m*). Hematoxylin-eosin stain, $\times 200$. **b** A comparable section has been labeled using the peroxidase-antiperoxidase (PAP) method with a primary antibody to EHN, AEC as the chromogen, and counterstained with hematoxylin. PAP staining, *white arrow*. $\times 250$. **c** Transmission electron micrograph from a section of the same kidney. Kidney tubule (*t*); interstitial cells (*ic*); assembly sites (*as*). Viruses (*v*) are associated with hematopoietic cells of the interstitial tissue. Bar represents 1 μm

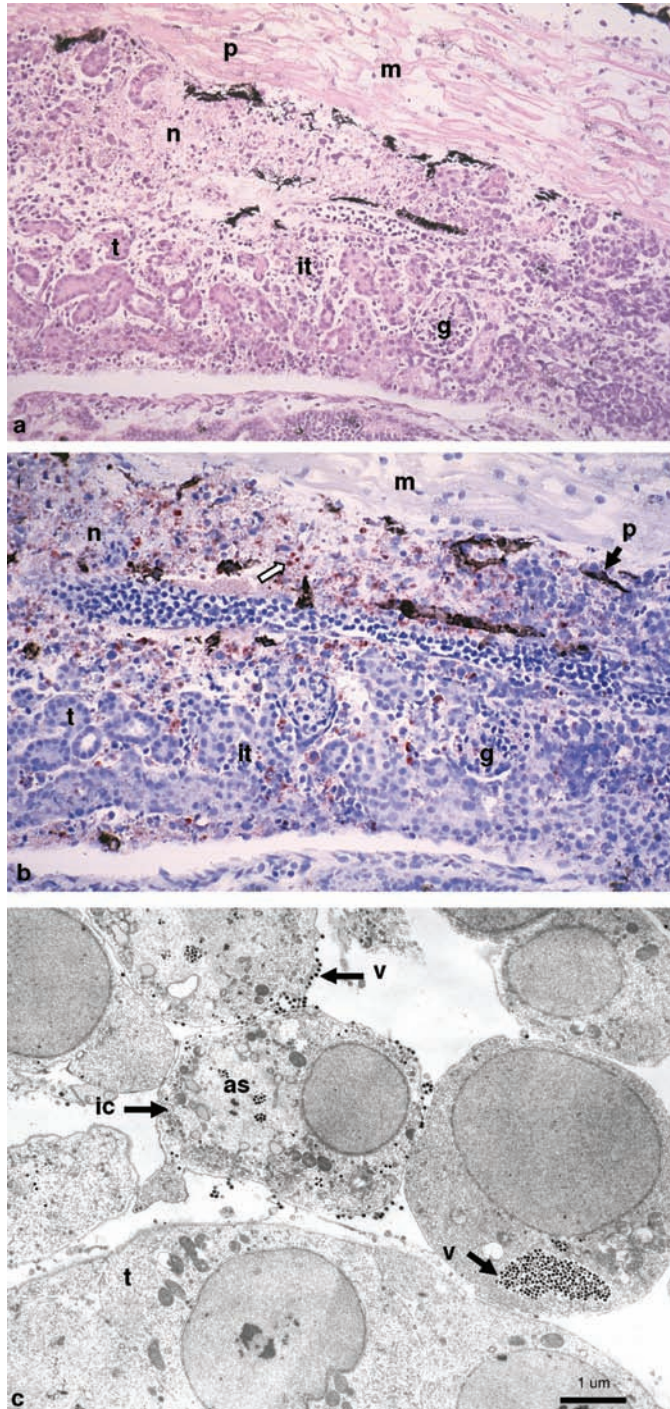

basophilic intracytoplasmic inclusions, which, upon electron microscopic examination, were identified as virus assembly sites (Fig. 4C). Within the liver, multifocal hepatocellular necrosis is apparent, whereas diffuse acute necrosis is seen in the spleen. Focal destruction of the pancreas is frequently observed, as is the degeneration of undifferentiated mesenchymal tissue in the developing limb buds. Another consistent and conspicuous change in infected rainbow trout and redfin perch is the presence of degenerate hematopoietic cells, basophilic debris, and fibrous material within blood vessels (Reddacliff and Whittington 1996). Degeneration of the vascular endothelium is observed in the liver, spleen, kidney, gill and heart, suggesting that the virus is endotheliotropic. The clinical signs and histopathology described above differ from that seen following infection with other ranaviruses (Cunningham et al. 1996; Jancovich et al. 1997; Bollinger et al. 1999) in that the Australian viruses do not cause major skin lesions or megalocytosis. Therefore, it appears that ranavirus pathology varies depending upon the virus species and host animal infected. Recently recombinant BIV has been constructed using homologous recombination to replace the viral homolog of eIF-2 α with a cassette containing the neomycin resistance gene and the globin gene from adult cane toads (Pallister et al. 2007). Not only does this illustrate the feasibility of constructing iridovirid knock out mutants, but the expression of adult globin suggests that recombinant BIV may be useful in the biological control of cane toads.

RSIV and Other Megalocytiviruses from Asia

Megalocytivirus is a newly established genus within the family *Iridoviridae*. Numerous megalocytivirus isolates have been described, but it has not yet been determined whether these represent distinct viral species or merely strains or isolates of a single species. Sequence analysis of the highly conserved MCP suggests that there may be two clusters within the genus (Do et al. 2005b; Wang et al. 2007). Alternatively, since the isolates come from different fish species, it is not clear if they represent host-specific species or a single species with a broad host range. The complete genomic DNA sequences of four megalocytiviruses has been determined: infectious spleen and kidney necrosis virus (ISKNV, He et al. 2001), red sea bream iridovirus (RSIV, Kurita et al. 2002), rock bream iridovirus (RBIV, Do et al. 2004), and orange spotted grouper iridovirus (OSGIV, Lu et al. 2005). ISKNV was chosen as the type species of the genus because it was the first megalocytivirus whose complete sequence was published. However, extensive work has been carried out in Japan on RSIV and provides much of what we know about the biology of this genus.

Host Range

Epizootics caused by megalocytiviruses first occurred among red sea bream in 1990 (Nakajima and Maeno 1998; Nakajima and Kunita 2005). Subsequently,

outbreaks were noted in brown spotted groupers (*Epinephelus tauvina*) in Singapore in 1992 (Chua et al. 1994) and among Malabar groupers (*E. malabaricus*) and sea bass (*Lateolabrax* spp.) in southern Thailand in 1993 (Danayadol et al. 1996). Based on the presence of icosahedral particles within the cytoplasm and characteristic enlarged cells (designated inclusion body-bearing cells), megalocytiviruses have been found in ornamental tropical fishes such as dwarf gourami (*Cosa lalia*) that were imported into Australia from Singapore in 1988 (Anderson et al. 1993) and in orange chromide cichlids (*Etroplus maculatus*) imported to Canada from Singapore in 1989 (Armstrong et al. 1989). Moreover, a similar disease was also observed in ornamental tropical fish such as angelfish (*Pterophyllum scalare*) in the UK (Rodger et al. 1997), and gouramis and swordtails (*Xiphophorus hellerii*) in Israel (Paperna et al. 2001), which were bred in those countries after being imported from Singapore. A megalocytivirus was also isolated from diseased African lamp-eyes (*Aplocheilichthys normani*) that were cultured in Indonesia and imported into Japan (Sudthongkong et al. 2001). Sequence analysis showed that the isolates designated GSDIV (grouper sleepy disease iridovirus), SBIV (sea bass iridovirus), DGIV (dwarf gourami iridovirus), RSIV, TGIV (Taiwan grouper iridovirus), and ALIV (African lampeye iridovirus) were essentially genetically identical and likely represent strains or isolates of the same viral species (Sudthongkong et al. 2002). Collectively, these reports suggest that megalocytiviruses originated in Southeast Asia and are pathogenic to both marine and freshwater fishes. The appearance of clinical disease in farmed and imported fish might reflect the effects of crowding, or transport- and handling-induced stresses on the immune system that exacerbate preexisting subclinical infections. Moreover, the age of the fish and water temperature appear to be important factors in determining the outcome of RSIV infection (Choi et al. 2006). Because grouper species are of high economic value, fish farming has likely resulted in virus dispersal and an increase in the prevalence of the disease in Southeast Asian countries such as Singapore, Thailand, Indonesia, Malaysia, and Taiwan. Mass mortalities of farmed grouper species and ornamental freshwater fish have resulted in large economic losses in those countries. The recent identification of markedly similar megalocytiviruses in Murray cod and dwarf gouramis, coupled with the high prevalence of megalocytivirus infections in retail aquarium shops in Sydney, Australia, suggests that the global trade in ornamental fish may also facilitate the spread of this virus to new host species in geographically distant regions (Go et al. 2006; Go and Whittington 2006).

Isolation and Characterization of RSIV

In the summer of 1990, mass mortalities occurred among farmed red sea bream in Japan when the water temperature rose above 25°C. An iridovirus-like agent was detected in diseased fish and designated red sea bream iridovirus after the host species from which it was isolated (Inouye et al. 1992). RSIV is the most extensively studied of the megalocytiviruses and has been shown to infect more than 30 species of farmed marine fish including sea bass, amberjack, yellowtail

(*Seriola quinqueradiata*), striped jack (*Pseudocaranx dentex*), and rock bream (*Oplegnathus fasciatus*). It is likely that the importation of infected seedlings captured in the South China Sea was responsible for the introduction of RSIV into Japan. In addition, epizootics of RSIV-induced disease occurred in farmed red sea bream, rock bream, Japanese flounder (*Paralichthys olivaceus*), and turbot (*Scophthalmus maximus*) in Korea (Jung et al. 2000, Do et al. 2005a, 2005b), and in mandarin fish (*Siniperca chuatsi*) reared in offshore pens in the South China Sea (He et al. 2000) as well as in stocks of amberjack seedlings from Hainan Island. Although most studies to date have focused solely on identifying the viral agent responsible for disease, and developing accurate diagnostic tools, the transcriptional program of RSIV has recently been elucidated using DNA microarray technology (Lua et al. 2005, 2007). Given the economic importance of this viral agent, additional molecular studies should be forthcoming.

Clinical Signs: Gross and Histopathological Findings

Clinically, diseased fish show a darkening of body color and become lethargic immediately before dying. The latter symptom is so prominent that the common name for the infection is sleepy disease. Splenomegaly is marked in diseased fish, and cell enlargement is evident (Fig. 5A). In some cases, necrosis of splenocytes and hematopoietic cells is observed. It is thought that the enlarged cells observed in the spleen, kidney, liver, gills, and heart of infected fish are cells of the macrophage/monocyte lineage (T. Miyazaki, unpublished observations). From a diagnostic viewpoint, these enlarged cells, which are termed inclusion body-bearing cells, are pathognomonic for megalocytivirus infections.

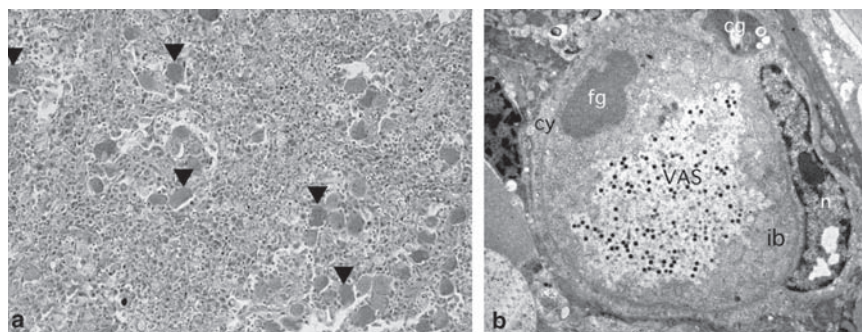

Fig. 5 Histopathological changes within megalocytivirus-infected cells. **a** Spleen cells from red sea bream infected with RSIV were stained by Mayer's hematoxylin and eosin and examined by light microscopy. Characteristic of RSIV infection is the presence of large, inclusion body-bearing cells (indicated by *arrowheads*) within the spleen. **b** A mature inclusion body-bearing cell with a large, centrally located inclusion body containing masses of fine granules (*fg*) and coarse granules (*cg*) and a well-developed viral assembly site (*VAS*) containing numerous viral particles. The nucleus (*n*) and cytoplasm (*cy*) have been displaced to the periphery by the enlarging *VAS*. (**b** from Mahardika et al. 2004, with permission)

As with other iridovirids, inclusion bodies contain viral DNA and serve as the sites of virion formation. However, in contrast to ranavirus-infected cells, a membrane surrounds the inclusion body found within RSIV-infected spleen cells (compare Figs. 3A and 5B). Moreover, the inclusion body occupies most of the volume of the cell and displaces the cytoplasm and nucleus to the periphery. The membrane-bound inclusion contains not only the viral assembly site, but also mitochondria, rough and smooth endoplasmic reticulum, and two types of electron-dense matrices, one composed of fine granules and another composed of coarse or rough granules (Mahardika et al. 2004). It has been suggested that fine granules contain viral DNA and that virions form in close association with this structure. Rough granules are thought to represent viral DNA that has recently been transported from the nucleus to the cytoplasm (Mahardika et al. 2004). Although, membrane-bound inclusions were initially seen only in cells from infected fish, recent studies examining RSIV-infected grunt fin cells demonstrated the presence of inclusion bodies in vitro (K. Mahardika and T. Miyazaki, unpublished observations). However, it remains to be determined if assembly site formation among megalocytiviruses is a fundamentally different process from that seen among other iridovirids or whether the generation of inclusion body-bearing cells represents the engulfment of infected cells by neighboring cells or macrophages (Overholtzer et al., 2007).

Vaccine Development

Given the commercial value of the fish species affected, vaccine development has been a priority. An injectable vaccine using formalin-inactivated RSIV is efficacious in protecting red sea bream, yellowtail, amberjack, kelp grouper, and other species from RSIV infection and has been commercialized (Nakajima et al. 1999, 2002; Caipang et al. 2006a). Moreover, a DNA vaccine and an oral vaccine using liposome-entrapped RSIV antigens are also effective (Caipang et al. 2006b; T. Miyazaki, unpublished observations). Because oral vaccination is more practical for large-scale administration to susceptible fish, commercialization of an oral RSIV vaccine will be a significant breakthrough in the protection of farmed fish against RSIV infection.

Invertebrate Iridescent Viruses

Invertebrate iridescent viruses (IIVs) infect mostly arthropods, particularly the immature stages of insects inhabiting damp or aquatic environments. The IIVs are currently classified into two genera, *Iridovirus* and *Chloriridovirus*, based on particle size and genetic characteristics. Members of the genus *Iridovirus* have a particle diameter of approximately 120–130 nm in ultrathin section and have been isolated from many orders of insects, terrestrial isopods, and shrimp (Williams 1998; Tang et al. 2007). There are also a number of reports of iridovirus infections

of marine and freshwater invertebrates, including bivalve, gastropod and cephalopod mollusks, a daphnid, and an annelid worm, although the relationship between these viruses and those that infect insects and isopods is uncertain (for a recent example, see Gregory et al. 2006). In contrast, members of the genus *Chloriridovirus* are larger (~180 nm in ultrathin section) and infect the aquatic stages of mosquitoes and midges. The first IIV was isolated from soil-dwelling crane fly larvae (*Tipula paludosa*) in England in 1954, and subsequently IIV infections have been reported from every continent except Antarctica.

IIV Species Relationships

IIVs have received little attention over the past several decades and there is a paucity of genomic sequence information and other comparative studies that form the basis for defining species within these genera. Currently, the genus *Iridovirus* comprises two species, *Invertebrate iridescent virus 1* (IIV-1) and *Invertebrate iridescent virus 6* (IIV-6), and 11 tentative species whose status can only be resolved as additional information becomes available. Sequence comparisons of the MCP, DNA hybridization studies, and serological evidence indicate that isolates in the genus *Iridovirus* can be divided into three groups, or complexes (Williams and Cory 1994; Webby and Kalmakoff 1998). The largest group comprises IIV-1, -2, -9, -16, -22, -23, -24, -29, -30, *Anticarsia gemmatilis* IV, and an undescribed isolate from a weevil. The second group comprises IIV-6 and related strains of this virus (*Gryllus* IV, IIV-21, IIV-28). The third group comprises IIV-31 from terrestrial isopods and Pj-IV from the Japanese beetle (*Popillia japonica*). Recognition of these complexes should prove valuable for the future classification of novel IIV isolates.

The taxonomic situation is even more unsatisfactory for the genus *Chloriridovirus*, which, despite numerous records of infections in many species of mosquitoes and midges of medical and veterinary importance, consists of a single species, *Invertebrate iridescent virus 3* (IIV-3) from the saltmarsh mosquito, *Ochlerotatus* (*Aedes*) *taeniorhynchus*. DNA hybridization and sequence information based on the MCP and DNA polymerase support the classification of this virus in a separate genus (Williams and Cory 1994; Stasiak et al. 2000). However, recent analysis of the complete genome of IIV-3 indicates that some invertebrate iridoviruses that had previously been classified along with IIV-1 within the genus *Iridovirus* now cluster closer to IIV-3 than to IIV-6 (Delhon et al. 2006).

Genomic Characteristics

Unlike virtually all vertebrate iridovirids, the IIV genome is not methylated, or methylated at a very low level that likely reflects the activity of cellular DNA methyltransferases. To date, only two IIV genomes have been sequenced completely: IIV-3 and IIV-6 (Jakob et al. 2001; Delhon et al. 2006). The genome of

IIV-6 is 212 kbp (unique portion) with a G+C content of 28.6% (Jakob et al. 2001). Although the original description of the IIV-6 genome predicted 468 ORFs, this value is likely an overestimate since it includes both overlapping and nonoverlapping ORFs. If only nonoverlapping reading frames are considered, then IIV-6 likely encodes approximately 200 ORFs, a figure consistent with the potential genetic content of vertebrate iridoviruses (Williams et al. 2005; Eaton et al. 2007; Tsai et al. 2007). Clearly, the only way to resolve the authenticity of potential overlapping reading frames is to identify viral transcripts by Northern blotting or RT-PCR. Using that approach, D'Costa et al. (2004) identified 137 IIV-6 transcripts, a value that is likely an underestimate due to the presence of low copy number transcripts. The genome of IIV-3 (genus *Chloriridovirus*) is 191 kbp (unique portion) with a G+C content of 48% and encodes 126–143 putative nonoverlapping ORFs (Delhon et al. 2006; Eaton et al. 2007; Tsai et al. 2007). Despite the aforementioned clustering of IIV sequences, IIV-3 and IIV-6 are considered members of separate viral genera based on the lack of colinearity between their genomes, the low sequence identity seen between homologous genes, virion size, and host range.

In addition to the core iridovirid genes involved in replication and nucleotide metabolism, other genes of interest in IIV-6 include an inhibitor of apoptosis (*iap*), an NAD⁺-dependent DNA ligase, and putative homologs of peptides with antibacterial and antifungal properties (Jakob et al. 2001; Tanaka et al. 2003). Two adjacent ORFs have been detected in IIV-6 with homology to eukaryotic poly(ADP-ribose)transferase (pART), an enzyme that plays an important role in genome repair and maintenance (Otto et al. 2005). Between one and three copies of homologs to *bro* genes (baculovirus repeated ORFs) of lepidopteran ascoviruses have been detected in IIV-6 and IIV-31 (Bideshi et al. 2003). *Bro* genes are a multi-gene family of unknown function that may influence host DNA replication or transcription by regulating host chromatin structure (Zemskov et al. 2000). They are present in baculoviruses, entomopoxviruses, phycodnaviruses, and a number of bacteriophages and bacterial transposons. Interestingly, the large subunit of the IIV-6 ribonucleotide reductase contains an intein, a form of selfish genetic element that removes itself from the protein by posttranslational autocatalytic splicing (Petrokovski 1998). Thirty-three genes are unique to IIV-3 and include a putative S/T protein kinase, a mutT-like protein, and RNA Pol II subunits with similarities to those of fungi (Delhon et al. 2006).

As with other iridovirids, IIV genomes contain extensive regions of repetitive DNA that account for 20% (IIV-3) to over 25% (IIV-9) of the genome (Fisher et al. 1988; McMillan et al. 1990; Delhon et al. 2006). The coding function of these regions is unknown, although late transcripts were detected in the IIV-9 repeat region. The pattern of repetitive DNA in the genome of IIV-6 is complex and involves boxes of tandem repeats and others with a number of different interdigitated repeat sequences of variable size and homology. Promoter regions for the MCP and DNA polymerase genes of IIV-6 have been located 29–53 and 6–27 nucleotides upstream of their respective transcriptional start sites (Nalcacioglu et al. 2003).

Structural Characteristics

Structural studies of IIV are far more advanced than those of vertebrate iridoviruses and have revealed much about virion architecture. Building on early electron microscope studies (Wrigley 1969, 1970; Stoltz 1971, 1973), high-resolution cryo-electron microscopy and three-dimensional image reconstructions revealed IIV-6 particles in quasi-crystalline hexagonal arrays with an interparticle distance of 40–60 nm (Yan et al. 2000). Particle diameter was calculated at 162 nm along the two- and threefold axes of symmetry and 185 nm along the fivefold axis; considerably larger than the diameter observed in ultrathin sections or by negative staining. The outer capsid comprises a pseudo-hexagonal array of trimeric capsomers, 8 nm in diameter and 7.5 nm high. A thin fiber projects radially from the surface of each capsomer and likely regulates interparticle distance, a key characteristic for the iridescence of infected hosts. Such fibers are also seen in some vertebrate iridoviruses, such as LCDV-1 (Zwillenberg and Wolf 1968), but are not seen in enveloped virions released by budding. The major capsid protein of 51.4 kDa represents roughly 40% of the particle weight and forms hexavalent capsomers comprising an external noncovalent trimer and an internal trimer linked by disulfide bonds. The capsomers are arranged into trisymmetron and pentasymmetron facets. Each particle comprises 1,460 capsomers and an additional 12 pentavalent capsomers located singly at the center of each pentasymmetron. The triangulation number (T) is 147. Large IIVs that infect mosquitoes and midges have larger facets, giving a likely 1,560 subunits per particle (Stoltz 1971, 1973). A lipid bilayer, 4 nm thick, surrounds a highly hydrated DNA core that is arranged in a long coiled filament 10 nm in diameter. The lipid component is intimately associated with an additional inner shell beneath the fused layer of the capsid. Core and capsid polypeptides appear to be connected by intermembrane proteins passing through the lipid layer. Sensitivity to lipid solvents in IIVs varies with the assay system used (Martínez et al. 2003). Most of the polypeptide diversity of IIVs appears to be associated with the core and lipid membrane (Cerutti and Devauchelle 1990).

Host Range

The host range of IIVs depends on the route of infection. Most IIVs cause lethal infections in a broad range of insects and other arthropod species following injection of the virus. In contrast, host range following oral administration tends to be far more restricted. The best studied example is IIV-6, which, in laboratory studies, infects species from all major insect orders and a number of other arthropods, including isopods and a centipede (Ohba 1975; Ohba and Aizawa 1979). Others, such as IIV-3, IIV-16, or IIV-24, naturally infect just one or two closely related host species. IIVs are clearly capable of replication in host species that do not develop signs of disease (Ohba 1975; Ward and Kalmakoff 1991), but systematic studies are required to determine the range of species susceptible to such asymptomatic infections. Virus propagation *in vitro* is readily achieved in dipteran and lepidopteran cell lines, and in

recently developed cell lines from Homoptera and Coleoptera. Almost all IIVs, with the notable exceptions of IIV-3, IIV-16, and IIV-24, can be grown in massive quantities in the standard laboratory host, *Galleria mellonella* (Lepidoptera: Pyralidae). The *in vivo* host range of invertebrate iridoviruses does not extend to vertebrates (Kelly and Robertson 1973; Ohba and Aizawa 1982). Although an IIV-6-like virus has been reported from reptiles (Just et al. 2001), the need for caution regarding this report has been emphasized previously (Williams et al. 2005). Resolution of this controversy will require additional study since members of some viral families (e.g., *Flaviviridae*) are able to replicate in both invertebrates and endothermic vertebrates.

IIVs Cause Lethal and Sublethal Disease

IIVs replicate extensively in most host tissues, especially the epidermis, muscle, fat body, nerves, hemocytes, and areas of the gut. Virus particles assemble into paracrystalline arrays within the cell cytoplasm and cause the iridescence that is characteristic of patent infections. Light reflected from the surface of close packed particles causes interference with incident light, a phenomenon known as Bragg diffraction. Purified pellets of IIV particles are also iridescent. Patently infected holometabolous insects, i.e., species that undergo complete metamorphosis, often die in the larval stage, but those that survive to pupate frequently show marked deformities and usually die in the pupal stage. IIVs can also cause patent infection in the adult stages of isopods, bees, and crickets. Some isolates have unusually long external fibrils attached to the capsid that increase the interparticle distance; these isolates do not display iridescence at visible wavelengths (Stoltz et al. 1968).

It is now apparent that iridescence is not a reliable indicator of IIV infection given that many hosts can be infected sublethally and show no obvious signs of disease. The density of IIV particles in sublethally infected insects is far lower than seen in the cells of patently infected individuals (Tonka and Weiser 2000). Such covert infections have been reported in natural populations of blackflies, *Simulium variegatum* (Williams 1993), and mayflies, *Ecdyonurus torrentis* (Tonka and Weiser 2000), and in laboratory populations of a mosquito, *Aedes aegypti* (Marina et al. 1999), and a moth, *Galleria mellonella* (Constantino et al. 2001). Covert infections have been detected by PCR amplification of the MCP gene, electron microscope observations, and insect bioassay techniques. Covert infection of *Ae. aegypti* by IIV-6 results in an increase in larval development time and reductions in adult body size and longevity. The reproductive capacity of covertly infected mosquitoes is reduced by 22%–50% compared to healthy mosquitoes (Marina et al. 2003a, 2003b, 2003c).

Ecology

The incidence of patent disease in host populations is typically very low, although occasional epizootics have been observed in lepidopteran species (Sikorowski and Tyson 1984; Sieburth and Carner 1987), crickets (Fowler 1989),

craneflies (Ricou 1975), mosquitoes (Fedorova 1986), and blackfly larvae (Hernández et al. 2000). Studies on blackflies and Lepidoptera have indicated that there exists considerable genotypic variation in IIV populations; individual insects collected at the same place and time differed in their respective RFLP profiles and in the size of the restriction fragments that hybridized to an MCP gene probe in Southern blots (Williams and Cory 1994; Williams, unpublished data).

There is clear evidence of seasonality in the prevalence of IIV infections that correlates with fluctuations in precipitation and soil humidity and/or host densities (Ricou 1975; Grosholz 1993; Hernández et al. 2000). The persistence of IIV-6 in soil depends very much on moisture content (Reyes et al. 2004) and the presence of clay and iron minerals (Christian et al. 2006). In contrast, IIV persistence in water is markedly affected by solar ultraviolet radiation; a rapid loss of activity is observed following exposure to direct sunlight (Hernández et al. 2005).

The route of infection is uncertain for most IIV-host systems. Cannibalism or predation of infected individuals appears to be the principal mechanism of transmission in populations of mosquitoes (Linley and Nielsen 1968a, 1968b), isopods (Federici 1980; Grosholz 1992), tipulids (Carter 1973a, 1973b), crickets (Fowler 1989), and cannibalistic Lepidoptera (Williams and Hernández 2006). IIV particles can be transmitted from infected to susceptible insects by hymenopteran parasitoids and entomopathogenic nematodes (Mullens et al. 1999; Lopez et al. 2002). IIV-3 survives in populations of *O. taeniorhynchus* by alternating cycles of horizontal transmission among cannibalistic larvae and vertical transmission from adult female mosquitoes that acquire a sublethal infection shortly before pupating (Linley and Nielsen 1968a, 1968b). Horizontal transmission is more prevalent in high-density populations of some species wherein the frequency of aggressive interactions between conspecifics and the probability of wounding is greater than at low densities (Grosholz 1993; Marina et al. 2005). Physical abrasion also results in an increased probability of infection (Carter 1973b; Undeen and Fukuda 1994).

Economic Importance

Theoretical studies suggest that the impact of sublethal disease on the population dynamics of certain species may be considerable and merits further investigation, particularly in the case of medically important insect vectors such as mosquitoes (Boots et al. 2003; Marina et al. 2003a). However, IIVs are not presently considered to be useful agents for the biological control of insect pests because of the low prevalence of lethal disease, their potentially broad host range, and their poor ability to be transmitted by ingestion. IIV infections are suspected to periodically devastate populations of the mopane worm, which is an economically important species of caterpillar harvested for human consumption in southern African countries. Oyster populations also suffer serious disease, although the causative agents have been poorly characterized (Elston 1997). Recently, the use of IIVs in industrial applications has aroused some interest, specifically their role as bioscaffolds in the construction of metal nanostructures with unique optical and dielectric properties for use in nanotechnological applications (Juhl et al. 2004; Radloff et al. 2005a,b).

LCDV and White Sturgeon Iridovirus

Although LCDV was not the first iridovirid to be isolated (that distinction goes to IIV-1), the characteristic signs of LCDV infection meant that lymphocystis disease was the first iridovirid disease to be described. Fish infected with what we now know to be LCDV were identified more than a century ago based on the distinctive appearance of diseased animals (reviewed in Weissenberg 1965; Wolf 1988; Bremont and Bernard 1995; Chinchar 2000). Infection with LCDV induces wart-like lesions generally on the skin, but also on internal organs, in numerous species of freshwater and marine fish (Dukes and Lawler 1975). Unlike papillomavirus-induced warts that result from an increased number of infected cells (hyperplasia), LCDV-mediated warts represent the enlargement of single infected cells. Lymphocystis cells are commonly 100 μm or more in diameter and can coalesce to form large masses several millimeters in diameter. Infected cells possess a thick hyaline capsule, a central enlarged nucleus, and prominent basophilic DNA inclusions (Wolf 1988). Low numbers of LCDV-induced warts are not in themselves life-threatening, but in high numbers they may impair respiration, feeding, and movement, making infected fish more susceptible to predation (<http://www.maine.gov/ifw/fishing/fishlab/vol4issue10.htm>). Moreover, external lesions reduce the commercial value of both food fish and aquarium stock.

Despite its early identification, LCDV has not been as extensively studied at the molecular level as other iridovirids because of its inability to be readily propagated in cell culture. Recently, the complete genomic sequences of what are likely two different viral species, one from plaice and flounder isolated from the Atlantic Ocean (LCDV-1, Tidona and Darai 1997) and a second from olive flounder in China (LCDV-C, Zhang et al. 2004) have been described. Additional putative species/isolates from infected dabs (LCDV-2, Wolf 1988), rockfish (Kitamura et al. 2006; Kim et al. 2007), and largemouth bass (Hanson et al. 2006) have been identified but not completely sequenced. Aside from the standard array of replicative genes (Eaton et al. 2007), LCDV contains at least two novel putative immune evasion genes, a protein with homology to members of the tumor necrosis factor receptor family (Essbauer et al. 2004) and another with similarity to a G protein-coupled receptor (Huang et al. 2007b).

Although diagnosis of LCDV infections is often made based on clinical and histological signs (i.e., wart-like external lesions), serological and molecular techniques have been developed to enhance the rapidity and specificity of diagnosis (Cano et al. 2006). No vaccines are currently available for preventing LCDV-induced disease, and there is no specific treatment for an ongoing infection. A DNA vaccine has been developed, but its efficacy is unknown (Zheng et al. 2006). Little is known about immunity to LCDV, but there is the suggestion that by replicating primarily in the skin, LCDV is shielded from an antiviral response until late in infection. Although fish can be reinfected with LCDV, subsequent infections are not as extensive, suggesting that immunity plays a role in ameliorating infection. Transmission of LCDV is thought to occur by direct contact between infected and uninfected fish and is likely increased by high population densities. In surviving fish, LCDV lesions resolve spontaneously. The recent identification of a single

major genetic locus controlling susceptibility to LCDV infection in Japanese flounder opens the way to selective breeding programs designed to develop flounder populations that are highly resistant to lymphocystis disease (Fuji et al. 2006).

WSIV is currently an unclassified member of the family *Iridoviridae* and causes lethal infections in farm-reared juvenile white sturgeon (Georgiadis et al. 2001; Hedrick et al. 1992b; Watson et al. 1998). Several procedures commonly encountered in the culture of white sturgeon, such as rearing at high densities, contribute to patent disease because of infection originating from asymptomatic individuals (Georgiadis et al. 2001, 2002; Drennan et al. 2005). WSIV has an affinity for epithelial cells and infects the gills, skin, olfactory organ, barbells, and esophagus. Electron microscopy identified large (~270 nm in diameter) icosahedral virions within infected cells and tentatively classified this agent as an iridovirus (Hedrick et al. 1990). Preliminary sequence analysis showed little similarity to other known viruses with the exception of partial sequence similarity to the MCP of mimivirus and members of the *Iridoviridae* and *Phycodnaviridae* families. A PCR assay has been developed to detect the presence of the WSIV MCP gene (Kwak et al. 2006) and has proved effective in the diagnosis of asymptotically infected individuals (Drennan et al. 2007).

Conclusions and Future Directions

The fundamentals of the iridovirid replication strategy were elucidated by Granoff, Willis, Goorha, and their co-workers more than 20 years ago. However, despite this commendable start, much remains to be done in terms of determining the precise roles that specific viral proteins play in the virus life cycle. Moreover, we now appreciate the fact that viral proteins not only control viral biogenesis, but also likely regulate evasion of the immune system, host range, and virulence. Recent studies indicate that gene silencing using siRNAs and targeted knockdown techniques based on asMOs offer the opportunity to block expression of specific viral genes and infer their function from the resulting changes in phenotype. In addition, it may soon be possible to knock out specific viral genes via homologous recombination and assess the role of these deletion mutants both *in vitro* and *in vivo*. From the immunological point of view, the FV3/*Xenopus* model developed by Robert and his colleagues offers an excellent approach for examining antiviral responses in a well-characterized amphibian system. Moreover, the growing awareness of the impact of iridovirid-mediated mortality in various fish and amphibian species suggests that ecologists, ichthyologists, fish and frog farmers, virologists, and immunologists need to pool their efforts to understand the biological and ecological basis underlying the die-off phenomena. Efforts along these lines are currently underway (Grant et al. 2005; Inendino et al. 2005; Pearman and Garner 2005; <http://lifesciences.asu.edu/irceb/amphibians>). With the growing global dependence on aquaculture as a human food source and increasing concerns about

the decline in natural amphibian populations, it is critical that we understand the biology of one of the major families of viral pathogens infecting cold-blooded vertebrates. In addition, it is time that the life cycle of invertebrate iridoviruses be subjected to the same molecular dissection that has been applied to their vertebrate counterparts. Specifically, molecular tools should be employed to elucidate the factors that modulate the virulence of IIV infections in insects, to determine the relationship between covert and patent infections, and to elucidate strategies of vertical transmission. Additional sequence information is also required to resolve the large number of tentative IIV species in the *Iridovirus* genus, and to delineate the diversity present in the *Chloriridovirus* genus that currently comprises just a single member.

Key areas of research in the coming years:

- Identification of the molecular composition of the viral RNA polymerase and determination of its precise role in viral transcription
- Identification of the cellular and molecular elements of antiviral immunity in fish and amphibians infected with ranaviruses
- Identification of the temporal class and promoter elements of key viral genes
- Elucidation of the function of key viral genes controlling replication, immune evasion, virulence, and host range through the use of asMO, siRNA, and gene knockout experiments
- Development of effective vaccines to protect captive and commercially important species from iridovirus-induced disease
- Clarification of the taxonomic relationships among these viruses, specifically the quantification of intra- and interspecific genotypic variation and the designation of genetic, biological, and ecological species-defining criteria that can be uniformly applied to the members of each genus
- Delineation of the factors that determine virulence and vertical transmission among invertebrate iridoviruses

Acknowledgements This work was partially supported by grants from the National Science Foundation, United States (Award No. DEB 02-13851).

References

- Ahne W, Schlotfeldt HJ, Thomsen I (1989) Fish viruses: isolation of an icosahedral cytoplasmic deoxyribovirus from sheatfish (*Silurus glanis*). *J Vet Med B* 36:333–336
- Ahne W, Bearzotti M, Bremont M, Essbauer S (1998) Comparison of European systemic piscine and amphibian iridoviruses with epizootic haematopoietic necrosis virus and frog virus 3. *J Vet Med B* 45:373–383
- Alcami A, Koszinowski UH (2000) Viral mechanisms of immune evasion. *Mol Med Today* 6:365–372
- Allen MJ, Schroeder DC, Holden MTG, Wilson WH (2006) Evolutionary history of the *Coccolithoviridae*. *Mol Biol Evol* 23:86–92

- Allender MC, Fry MM, Irizarry AR, Craig L, Johnson AJ, Jones M (2006) Intracytoplasmic inclusions in circulating leukocytes from an Eastern Box turtle (*Terrapene carolina carolina*) with an iridoviral infection. *J Wildlife Dis* 42:677–684
- Anderson IG, Prior HC, Rodwell BJ, Harris GO (1993) Iridovirus-like virions in imported dwarf gourami (*Colisa lalia*) with systemic amoebiasis. *Aust Vet J* 70:66–67
- Armstrong RD, Ferguson HW (1989) Systemic viral disease of the chromid cichlid *Etroplus maculatus*. *Dis Aquat Org* 7:155–157
- Ariel E, Tapiovaara H, Olesen NJ (1999) Comparison of pike-perch (*Stizostedion lucioperca*), cod (*Gadus morhua*) and turbot (*Scophthalmus maximus*) iridovirus isolates with reference to other piscine and amphibian iridovirus isolates. European Association of Fish Pathologists, VIII. International Conference on Diseases of Fish and Shellfish, Rhodes, Greece, 20–24 September
- Bauer S, Kirschning CJ, Hacker H, Redecke V, Hausmann S, Akira S, Wagner H, Lipford GB (2001) Human TLR9 confers responsiveness to bacterial DNA via species-specific CpG motif recognition. *Proc Natl Acad Sci U S A* 98:9237–9242
- Beattie E, Tartaglia J, Paoletti E (1991) Vaccinia virus-encoded eIF-2 alpha homolog abrogates the antiviral effect of interferon. *Virology* 183:419–422
- Bideshi DK, Renault S, Stasiak K, Federici BA, Bigot Y (2003) Phylogenetic analysis and possible function of *bro*-like genes, a multigene family widespread among large double-stranded DNA viruses of invertebrates and bacteria. *J Gen Virol* 84:2531–2544
- Bloch B, Larsen JL (1993) An iridovirus-like agent associated with systemic infection in cultured turbot *Scophthalmus maximus* fry in Denmark. *Dis Aquat Org* 15:235–240
- Boehme KW, Compton T (2004) Innate sensing of viruses by Toll-like receptors. *J Virol* 78:7867–7873
- Bollinger TK, Mao J, Schock D, Brigham RM, Chinchar VG (1999) Pathology, isolation and molecular characterization of an iridovirus from tiger salamanders in Saskatchewan. *J Wildlife Dis* 35:413–429
- Boots M, Greenman J, Ross D, Norman R, Hails R, Sait S (2003) The population dynamical implications of covert infections in host-microparasite interactions. *J Anim Ecol* 72:1064–1072
- Bouchier-Hayes L, Martin SJ (2002) CARD games in apoptosis and immunity. *EMBO Rep* 3:616–621
- Braunwald J, Tripier F, Kirm A (1979) Comparison of the properties of enveloped and naked frog virus 3 (FV3) particles. *J Gen Virol* 45:673–682
- Braunwald J, Nonnenmacher H, Tripier-Darcy F (1985) Ultrastructural and biochemical study of frog virus 3 uptake by BHK-21 cells. *J Gen Virol* 66:283–293
- Bremont J, Bernard M (1995) Molecular biology of fish viruses: a review. *Vet Res* 26:341–351
- Brunner JL, Schock DM, Collins JPI, Davidson EW (2004) The role of an intraspecific reservoir in the persistence of a lethal ranavirus. *Ecology* 85:560–566
- Brunner JL, Richards K, Collins JP (2005) Dose and host characteristics influence virulence of ranavirus infections. *Oecologia* 144:399–406
- Brunner JL, Schock DM, Collins JP (2007) Transmission dynamics of the amphibian ranavirus *Ambystoma tigrinum virus*. *Dis Aquat Org* 77:87–95
- Caipang CM, Hirono I, Aoki T (2006a) Immunogenicity, retention, and protective effects of the protein derivatives of formalin-inactivated red seabream iridovirus (RSIV) vaccine in red seabream, *Pagrus major*. *Fish Shellfish Immunol* 20:597–609
- Caipang CM, Takano T, Hirono I, Aoki T (2006b) Genetic vaccines protect red seabream, *Pagrus major*, upon challenge with red seabream iridovirus (RSIV). *Fish Shellfish Immunol* 22:130–138
- Cano I, Ferro P, Alonso MC, Bergmann SM, Romer-Oberdorfer A, Garcia-Rosado E, Castro D, Borrego JJ (2006) Development of molecular techniques for detection of lymphocystis disease virus in different marine fish species. *J Appl Microbiol* 102:32–40
- Carter JB (1973a) The mode of transmission of *Tipula* iridescent virus. I. Source of infection. *J Invert Pathol* 21:123–130
- Carter JB (1973b) The mode of transmission of *Tipula* iridescent virus. II. Route of infection. *J Invertebr Pathol* 21:136–143

- Cerutti M, Devauchelle G (1980) Inhibition of macromolecular synthesis in cells infected with an invertebrate virus (iridovirus type 6 or CIV). *Arch Virol* 63:297–303
- Cerutti M, Devauchelle G (1990) Protein composition of Chilo iridescent virus. In: Darai G (ed) *Molecular biology of iridoviruses*, Kluwer, Boston, pp 81–112
- Cerutti M, Cerutti P, Devauchelle G (1989) Infectivity of vesicles prepared from Chilo iridescent virus inner membrane: evidence for recombination between associated DNA fragments. *Virus Res* 12:299–314
- Chen ZX, Zheng JC, Jiang YL (1999) A new iridovirus isolated from soft-shelled turtle. *Virus Res* 63:147–151
- Chinchar VG (2000) Ecology of viruses of cold-blooded vertebrates. In: Hurst CJ (ed) *Virus ecology*, Academic, New York, pp 413–445
- Chinchar VG (2002) Ranaviruses (family *Iridoviridae*): emerging cold-blooded killers. *Arch Virol* 147:447–470
- Chinchar VG, Dholakia JN (1989) Frog virus 3-induced translational shut-off: activation of an eIF-2 kinase in virus-infected cells. *Virus Res* 14:207–224
- Chinchar VG, Granoff A (1984) Isolation and characterization of a frog virus 3 variant resistant to phosphonoacetate: genetic evidence for a virus-specific DNA polymerase. *Virology* 138:357–361
- Chinchar VG, Granoff A (1986) Temperature-sensitive mutants of frog virus 3: biochemical and genetic characterization. *J Virol* 58:192–202
- Chinchar VG, Mao J (2000) Molecular diagnosis of iridovirus infections in cold-blooded animals. *Sem Avian Exotic Pet Med* 9:27–35
- Chinchar VG, Yu W (1990) Frog virus 3-mediated translational shut-off: frog virus 3 messages are translationally more efficient than host and heterologous viral messages under conditions of increased translational stress. *Virus Res* 16:163–174
- Chinchar VG, Yu W (1992) Metabolism of host and viral mRNAs in frog virus 3-infected cells. *Virology* 186:435–443
- Chinchar VG, Goorha R, Granoff A (1984) Early proteins are required for the formation of frog virus 3 assembly sites. *Virology* 135:148–156
- Chinchar VG, Bryan L, Wang J, Long S, Chinchar GD (2003) Induction of apoptosis in frog virus 3-infected cells. *Virology* 306:303–312
- Chinchar VG, Essbauer S, He JG, Hyatt A, Miyazaki T, Seligy V, Williams T (2005) *Iridoviridae*. In: Fauquet CM, Mayo MA, Maniloff J, Desselberger U, Ball LA (eds) *Virus taxonomy: 8th report of the International Committee on the Taxonomy of Viruses*, Elsevier, London, pp 163–175
- Choi S-K, Kwon S-R, Nam Y-K, Kim S-K, Kim K-H (2006) Organ distribution of red sea bream iridovirus (RSIV) DNA in asymptomatic yearling and fingerling rock bream (*Oplegnathus fasciatus*) and effects of water temperature on transition of RSIV into acute phase. *Aquaculture* 256:23–26
- Chua HC, Ng, ML, Woo JJ, Wee JY (1994) Investigation of outbreaks of a novel disease, “Sleepy Grouper Disease,” affecting the brown-spotted grouper, *Epinephelus tauvina* Forskal. *J Fish Dis* 17:417–427
- Christian P, Richards AR, Williams T (2006) Differential adsorption of occluded and non-occluded insect pathogenic viruses to soil forming minerals. *Appl Environ Microbiol* 72:4648–4652
- Clark HF, Brennan JC, Zeigel RF, Karzon DT (1968) Isolation and characterization of viruses from the kidneys of *Rana pipiens* with renal adenocarcinoma before and after passage in the red eft (*Triturus viridescens*). *J Virol* 2:629–640
- Constantino M, Christian P, Marina CF, Williams T (2001) A comparison of techniques for detecting *Invertebrate iridescent virus 6*. *J Virol Meth* 98:109–118
- Coupar BEH, Goldie SG, Hyatt AD, Pallister JA (2005) Identification of a Bohle iridovirus thymidine kinase gene and demonstration of activity using vaccinia virus. *Arch Virol* 150:1797–1812
- Cunningham AA, Langton TES, Bennett PM, Lewin JF, Drury SEV, Gough RE, MacGregor SK (1996) Pathological and microbiological findings from incidents of unusual mortality of the common frog *Rana temporaria*. *Phil Trans R Soc Lond B* 351:1539–1557

- Danayadol Y, Direkbusarakom S, Boonyaratpalin S, Miyazaki T, Miyata M (1996) An outbreak of iridovirus-like infection in brown-spotted grouper (*Epinephelus malabaricus*) cultured in Thailand. *Aquat Anim Health Res Inst Newsletter* 5:6
- Davidson EW, Jancovich JK, Borland S, Newberry M, Gresens J (2003) Dermal lesions, hemorrhage, and limb swelling in laboratory axolotls. *Lab Animal* 32:23–24
- D'Costa SM, Yao H, Bilimoria SL (2001) Transcription and temporal cascade in Chilo iridescent virus infected cells. *Arch Virol* 146:2165–2178
- D'Costa SM, Yao HJ, Bilimoria SL (2004) Transcriptional mapping in Chilo iridescent virus infections. *Arch Virol* 149:723–742
- Delhon G, Tulman ER, Afonso CL, Lu Z, Becnel JJ, Moser BA, Kutish GF, Rock DL (2006) Genome of invertebrate iridescent virus type 3 (mosquito iridescent virus) *J Virol* 80:8439–8449
- Delius H, Darai G, Flügel RM (1984) DNA analysis of insect iridescent virus 6: evidence for circular permutation and terminal redundancy. *J Virol* 49:609–614
- De Voe R, Geissler K, Elmore S, Rotstein D, Lewbart G, Guy J (2004) Ranavirus-associated morbidity and mortality in a group of captive Eastern box turtles (*Terrapene carolina carolina*). *J Zoo Wildlife Med* 35:534–543
- Do JW, Moon C H, Kim HJ, Ko MS, Kim SB, Son JH, Kim JS, An EJ, Kim MK, Lee SK, Han MS, Cha SJ, Park MS, Park MA, Kim YC, Kim JW, Park JW (2004) Complete genomic DNA sequence of rock bream iridovirus. *Virology* 325:351–363
- Do JW, Cha SJ, Kim YC, An EJ, Lee NS, Choi HJ, Lee CH, Park MS, Kim JW, Kim YC, Park JW (2005a) Phylogenetic analysis of the major capsid protein gene of iridovirus isolates from cultured flounder *Paralichthys olivaceus* in Korea. *Dis Aquat Org* 64:193–200
- Do JW, Cha SJ, Kim JS, An EJ, Park MS, Kim JW, Lim YC, Park MA, Park JW (2005b) Sequence variation in the gene encoding the major capsid protein of Korean fish iridovirus. *Arch Virol* 150:351–359
- Docherty DE, Meteyer CU, Wang J, Mao J, Case ST, Chinchar VG (2003) Diagnostic and molecular evaluation of three iridovirus-associated salamander mortality events. *J Wildlife Dis* 39:556–566
- Drennan JD, Ireland S, LaPatra SE, Grabowski L, Carrothers TK, Cain KD (2005) High-density rearing of white sturgeon *Acipenser transmontanus* (Richardson) induces white sturgeon iridovirus disease among asymptomatic carriers. *Aquacult Res* 36:824–827
- Drennan JD, LaPatra SE, Samson CA, Ireland S, Eversman KF, Cain KD (2007) Evaluation of lethal and non-lethal sampling methods for the detection of white sturgeon iridovirus infection in white sturgeon, *Acipenser transmontanus* (Richardson). *J Fish Dis* 30:367–379
- Dukes TW, Lawler AR (1975) The ocular lesions of naturally occurring lymphocystis in fish. *Can J Comp Med* 39:406–410
- Eaton HE, Metcalf J, Penny E, Tcherepanov V, Upton C, Brunetti CR (2007) Comparative genomic analysis of the family *Iridoviridae*: Re-annotating and defining the core set of iridovirus genes. *Virology* 361:11–19
- Elston R (1997) Bivalve mollusk viruses. *World J Microbiol Biotechnol* 13:393–403
- Epifano C, Krijnse-Locker J, Salas ML, Rodriguez JM, Salas J (2006) The African swine fever virus nonstructural protein pB602L is required for formation of the icosahedral capsid of the virus particle. *J Virol* 80:12260–12270
- Essani K, Goorha R, Granoff A (1987) Mutation in a DNA binding protein reveals an association between DNA methyltransferase activity and a 26,000 Da polypeptide in FV3-infected cells. *Virology* 161:211–217
- Essbauer S, Ahne W (2002) The epizootic haematopoietic necrosis virus (*Iridoviridae*) induces apoptosis in vitro. *J Vet Med B* 49:25–30
- Essbauer S, Bremont M, Ahne W (2001) Comparison of the eIF-2 alpha homologous proteins of seven ranaviruses (*Iridoviridae*). *Virus Genes* 23:347–359
- Essbauer S, Fischer U, Bergmann S, Ahne W (2004) Investigations on ORF 167L of lymphocystis disease virus (*Iridoviridae*). *Virus Genes* 28:19–39
- Federici BA (1980) Isolation of an iridovirus from two terrestrial isopods, the pill bug, *Armadillidium vulgare* and the sow bug, *Porcellio dilatatus*. *J Invertebr Pathol* 36:373–381

- Fedorova VG (1986) On finding larvae of *Culex territans* Walk. and Dixidae infected with iridovirus in the forest zone of Novgorod region (in Russian). *Med Parazitol Mosk* 3:86–87
- Fischer M, Schnitzler P, Delius H, Darai G (1988) Identification and characterization of the repetitive DNA element in the genome of insect iridescent virus type 6. *Virology* 167:485–496
- Fox SF, Greer AL, Torres-Cervantes R, Collins JP (2006) First case of ranavirus-associated morbidity and mortality in natural populations of the South American frog *Atelognathus patagonicus*. *Dis Aquat Org* 72:87–92
- Fowler HG (1989) An epizootic iridovirus of Orthoptera (Grylotalpidae: *Scaptericus borellii*) and its pathogenicity to termites (Isoptera: Cryptoterme). *Rev Microbiol* 20:115–120
- Fuji K, Kobayashi K, Hasegawa O, Moura Coimbra MR, Sakamoto T, Okamoto N (2006) Identification of a single major genetic locus controlling the resistance to lymphocystis disease in Japanese flounder (*Paralichthys olivaceus*). *Aquaculture* 254:203–210
- Galli L, Pereira A, Márquez A, Mazzoni R (2006) Ranavirus detection by PCR in cultured tadpoles (*Rana catesbeiana* Shaw 1802) from South America. *Aquaculture* 257:78–82
- Gantress J, Bell A, Maniero G, Cohen N, Robert J (2003) *Xenopus*, a model to study immune responses to iridovirus. *Virology* 311:254–262
- Gendault J-L, Steffan A-M, Bingen A, Kim A (1981) Penetration and uncoating of frog virus 3 in cultured rat Kupffer cells. *Virology* 112:375–384
- Georgiadis MP, Hedrick RP, Johnson WO, Yun S, Gardner IA (2000) Risk factors for outbreaks of disease attributable to white sturgeon iridovirus and white sturgeon herpesvirus-2 at a commercial sturgeon farm. *Am J Vet Res* 61:1232–1240
- Georgiadis MP, Hedrick RP, Carpenter TE, Gardner IA (2001) Factors influencing transmission, onset and severity of outbreaks due to white sturgeon iridovirus in a commercial hatchery. *Aquaculture* 194:21–35
- Gil J, Garcia MA, Gomez-Puertas P, Guerra S, Rullas J, Nakano H, Alcami J, Esteban M (2004) TRAF family proteins link PKR with NF- κ B activation. *Mol Cell Biol* 24:4502–4512
- Glaser R, Litsky ML, Padgett DA, Baiocchi RA, Yang EV, Chen M, Yeh PE, Green-Church KB, Caligiuri MA, Williams MV (2006) EBV-encoded dUTPase induces immune dysregulation: implications for the pathophysiology of EBV-associated disease. *Virology* 346:205–218
- Go J, Whittington R (2006) Experimental transmission and virulence of a megalocytivirus (Family *Iridoviridae*) of dwarf gourami (*Colisa lalia*) from Asia in Murray cod (*Maccullochella peelii peelii*) in Australia. *Aquaculture* 258:140–149
- Go J, Lancaster M, Deece K, Dhungyel O, Whittington R (2006) The molecular epidemiology of iridovirus in Murray cod (*Mucullochella peelii peelii*) and dwarf gourami (*Colisa lalia*) from distant biogeographical regions suggests a link between trade in ornamental fish and emerging iridoviral diseases. *Mol Cell Probes* 20:212–222
- Goorha R (1981) Frog virus 3 requires RNA polymerase II for its replication. *J Virol* 37:496–499
- Goorha R (1982) Frog virus 3 DNA replication occurs in two stages. *J Virol* 43:519–528
- Goorha R, Dixit P (1984) A temperature-sensitive mutant of frog virus 3 is defective in second stage DNA replication. *Virology* 136:186–195
- Goorha R, Granoff A (1979) Icosahedral cytoplasmic deoxyriboviruses. In: Fraenkel-Conrat H, Wagner RR (eds) *Comprehensive virology*. Plenum, New York, pp 347–399
- Goorha R, Murti KG (1982) The genome of frog virus 3, an animal DNA virus, is circularly permuted and terminally redundant. *Proc Natl Acad Sci U S A* 79:248–262
- Goorha R, Murti G, Granoff A, Tirey R (1978) Macromolecular synthesis in cells infected by frog virus 3: VIII. The nucleus is a site of frog virus 3 DNA and RNA synthesis. *Virology* 84:32–50
- Goorha R, Willis DB, Granoff A, Naegele RF (1981) Characterization of a temperature-sensitive mutant of frog virus 3 defective in DNA replication. *Virology* 112:40–48
- Goorha R, Granoff A, Willis DB, Murti KG (1984) The role of DNA methylation in virus replication: inhibition of frog virus 3 replication by 5-azacytidine. *Virology* 138:94–102
- Granoff A, Came PE, Breeze DC (1966) Viruses and renal carcinoma of *Rana pipiens*: I. The isolation and properties of virus from normal and tumor tissues. *Virology* 29:133–148

- Grant EC, Inendino KR, Love WJ, Philipp DP, Goldberg TL (2005) Effects of practices related to catch-and-release angling on mortality and viral transmission in juvenile largemouth bass infected with largemouth bass virus. *J Aquat Anim Health* 17:315–322
- Green DE, Converse KA, Schrader AK (2002) Epizootiology of sixty-four amphibian morbidity and mortality events in the U S A 1996–2001. *Ann N Y Acad Sci* 969:323–339
- Greer AL, Berrill M, Wilson PJ (2005) Five amphibian mortality events associated with ranavirus infection in south central Ontario, Canada. *Dis Aquat Org* 67:9–14
- Gregory CR, Latimer KS, Pennick KE, Benson K, Moore T (2006) Novel iridovirus in a nautilus (*Nautilus* spp.). *J Vet Diagn Invest* 18:208–211
- Grosholz ED (1992) Interactions of intraspecific, interspecific and apparent competition with host-pathogen population dynamics. *Ecology* 73:507–514
- Grosholz ED (1993) The influence of habitat heterogeneity on host-pathogen population dynamics. *Oecologia* 96:347–353
- Hanson LA, Rudis MR, Vasquez-Lee M, Montgomery RD (2006) A broadly applicable method to characterize large DNA viruses and adenoviruses based on the DNA polymerase gene. *Virology* 3:28
- He JG, Wang SP, Zeng K, Huang ZJ, Chan SM (2000) Systemic disease caused by an iridovirus-like agent in cultured mandarin fish, *Siniperca chuatsi* (Basilewsky), in China. *J Fish Dis* 23:219–222
- He JG, Deng M, Weng SP, Li Z, Zhou SY, Long QX, Wang XZ, Chan SM (2001) Complete genome analysis of the mandarin fish infectious spleen and kidney necrosis iridovirus. *Virology* 291:126–139
- He JG, Lu L, Deng M, He HH, Weng SP, Wang XH, Zhou SY, Long QX, Wang XZ, Chan SM (2002) Sequence analysis of the complete genome of an iridovirus isolated from the tiger frog. *Virology* 292:185–197
- He W, Yin ZX, Li Y, Huo WL, Guan HJ, Weng SP, Chan SM, Je JG (2006) Differential gene expression profile in spleen of mandarin fish *Siniperca chuatsi* infected with ISKNV, derived from suppression subtractive hybridization. *Dis Aquat Org* 73:113–122
- Heath CM, Windsor M, Wileman T (2001) Aggresomes resemble sites specialized for virus assembly. *J Cell Biol* 153:449–456
- Hedrick RP, Groff JM, McDowell T, Wingfield WH (1990) An iridovirus infection of the integument of white sturgeon (*Acipenser transmontanus*). *Dis Aquat Org* 8:39–44
- Hedrick RP, McDowell TS, Ahne W, Torhy C, de Kinkelin P (1992a) Properties of three iridovirus-like agents associated with systemic infections of fish. *Dis Aquat Org* 13:203–209
- Hedrick RP, McDowell TS, Groff JM, Yun S, Wingfield WH (1992b) Isolation and properties of an iridovirus-like agent from white sturgeon *Acipenser transmontanus*. *Dis Aquat Org* 12:75–81
- Hernández O, Maldonado G, Williams T (2000) An epizootic of patent iridescent virus disease in multiple species of blackflies in Chiapas, Mexico. *Med Vet Entomol* 14:458–462
- Hernández O, Marina CF, Valle J, Williams T (2005) Persistence of invertebrate iridescent viruses in artificial tropical aquatic environments. *Arch Virol* 150:2357–2363
- Holm GH, Zurney J, Tumilasci V, Leveille S, Danthi P, Hiscott, Sherry B, Dermody TS (2007) RIG-I and IPS-1 augment proapoptotic responses following mammalian reovirus infection via IRF-3. *J Biol Chem* 282:21953–21956
- Hu GB, Cong RS, Fan TJ, Mei XG (2004) Induction of apoptosis in a flounder gill cell line by lymphocystis disease virus infection. *J Fish Dis* 27:657–662
- Huang X, Zhang Q (2007) Improvement and observation of immunoelectron microscopic method for the localization of frog *Rana grylio* virus (RGV) in infected fish cells. *Micron* 38:599–606
- Huang XH, Huang YH, Yuan XP, Zhang QY (2005) Electron microscopic examination of the viromatrix of *Rana grylio* virus in a fish cell line. *J Virol Methods* 133:117–123
- Huang YH, Huang XH, Gui JF, Zhang QY (2007a) Mitochondrion-mediated apoptosis induced by *Rana grylio* virus infection in fish cells. *Apoptosis* 12:1569–1577

- Huang YH, Huang XH, Zhang J, Gui JF, Zhang QY (2007b) Subcellular localization and characterization of G protein-coupled receptor homolog from lymphocystis disease virus isolated in China. *Viral Immunol* 20:150–159
- Hyatt AD, Whittington RJ (2005) Ranaviruses of fish, amphibians and reptiles: diversity and the requirement for revised taxonomy. *Dis Asian Aquacult* 5:155–170
- Hyatt AD, Parkes H, Zupanovic Z (1998) Identification, characterization and assessment of Venezuelan viruses for potential use as biological control agents against the cane toad (*Bufo marinus*) in Australia. Report from the Australian Animal Health Laboratory, CSIRO, Geelong, Australia
- Hyatt AD, Gould AR, Zupanovic Z, Cunningham AA, Hengstberger S, Whittington RJ, Kattenbelt J, Coupar BE (2000) Comparative studies of piscine and amphibian iridoviruses. *Arch Virol* 145:301–331
- Hyatt AD, Williamson M, Coupar BE, Middleton D, Hengstberger SG, Gould AR, Selleck P, Wise TG, Kattenbelt J, Cunningham AA, Lee J (2002) First identification of a ranavirus from green pythons (*Chondropython viridis*). *J Wildlife Dis* 38:239–252
- Imajoh M, Sugiura H, Oshima S (2004) Morphological changes contribute to apoptotic cell death and are affected by caspase-3 and caspase-6 inhibitors during red sea bream iridovirus permissive replication. *Virology* 322:220–230
- Inendino KR, Grant EC, Philipp DP, Goldberg TL (2005) Effects of factors related to water quality and population density on the sensitivity of juvenile largemouth bass to mortality induced by viral infection. *J Aquat Anim Health* 17:304–314
- Inouye K, Yamano K, Maeno Y, Nakajima K, Matsuoka M, Wada Y, Sorimahi M (1992) Iridovirus infection of cultured red sea bream, *Pagrus major* (in Japanese). *Fish Pathol* 27:19–27
- Iyer LM, Aravind L, Koonin EV (2001) Common origin of four diverse families of large eukaryotic DNA viruses. *J Virol* 75:11720–11734
- Jakob NJ, Muller K, Bahr U, Darai G (2001) Analysis of the first complete DNA sequence of an invertebrate iridovirus: coding strategy of the genome of *Chilo* iridescent virus. *Virology* 286:182–196
- Jancovich JK, Davidson EW, Morado JF, Jacobs BL, Collins JP (1997) Isolation of a lethal virus from the endangered tiger salamander *Ambystoma tigrinum stebbinsi*. *Dis Aquat Org* 31:161–167
- Jancovich JK, Davidson EW, Seiler A, Jacobs BL, Collins JP (2001) Transmission of the *Ambystoma tigrinum* virus to alternative hosts. *Dis Aquat Org* 46:159–163
- Jancovich JK, Mao J, Chinchar VG, Wyatt C, Case ST, Kumar S, Valente G, Subramanian S, Davidson EW, Collins JP, Jacobs BL (2003) Genomic sequence of a ranavirus (family *Iridoviridae*) associated with salamander mortalities in North America. *Virology* 316:90–103
- Jancovich JK, Davidson EW, Parameswaran N, Mao J, Chinchar VG, Collins JP, Jacobs BL, Storfer A (2005) Evidence for emergence of an amphibian iridoviral disease because of human-enhanced spread. *Mol Ecol* 14:213–224
- Johnson AJ, Pessier AP, Jacobson ER (2007) Experimental transmission and induction of ranaviral disease in Western ornate box turtles (*Terrapene ornata ornata*) and Red-eared sliders (*Trachemys scripta elegans*). *Vet Pathol* 44:285–297
- Johnson CL, Gale M Jr (2006) CARD games between virus and host get a new player. *Trends Immunol* 27:1–4
- Johnston JB, McFadden G (2003) Poxvirus immunomodulatory strategies: current perspectives. *J Virol* 77:6093–6100
- Juhl S, Ha YH, Chan E, Ward V, Smith A, Dokland T, Thomas EL, Vaia R (2004) Bioharvesting: optical characteristics of *Wiseana* iridovirus assemblies. *Polym Mat Sci Eng* 90:317–318
- Jung SJ, Oh MJ (2000) Iridovirus-like infection associated with high mortalities of striped beak-perch, *Oplegnathus fasciatus* (Temminck et Schlegel), in southern coastal areas of the Korean peninsula. *J Fish Dis* 23:223–226
- Just F, Essbauer S, Ahne W, Blahak S (2001) Occurrence of an invertebrate iridescent-like virus (*Iridoviridae*) in reptiles. *J Vet Med B* 48:685–694

- Kanchanakhan S (1998) An ulcerative disease of the cultured tiger frog, *Rana tigrina*, in Thailand: Virological examination. AAHRI Newsletter 7:1–2
- Kaur K, Rohozinski J, Goorha R (1995) Identification and characterization of the frog virus 3 DNA methyltransferase. J Gen Virol 76:1937–1943
- Kawagishi-Kobayashi M, Silverman JB, Ung TL, Dever TE (1997) Regulation of the protein kinase PKR by the vaccinia virus pseudosubstrate inhibitor K3L is dependent on residues conserved between the K3L protein and the PKR substrate eIF2 alpha. Mol Cell Biol 17:4146–4158
- Kelly DC, Robertson J (1973) Icosahedral cytoplasmic deoxyriboviruses. J Gen Virol 21:17–41
- Kelly DC, Tinsley TW (1974) Iridescent virus replication: a microscope study of *Aedes aegypti* and *Antherea eucalypti* cells in culture infected with iridescent virus types 2 and 6. Microbios 9:75–93
- Kim S, Kim HY, Lee S, Kim SW, Sohn S, Kim K, Cho H (2007) Hepatitis B virus X protein induces perinuclear mitochondrial clustering in microtubule- and dynein-dependent manners. J Virol 81:1714–1726
- Kim TJ, Lee JI (2007) Sequence variation in the genes encoding the major capsid protein, the ATPase, and the RNA polymerase 2 (domain 6) of lymphocystis disease virus isolated from Schlegel's black rockfish, *Sebastes schlegelii* Hilgendorf. J Fish Dis 30:501–504
- Kitamura SI, Jung SJ, Kim WS, Nishizawa T, Yoshimizu M, Oh MJ (2006) A new genotype of lymphocystis virus, LCDV-RF, from lymphocystis diseased fish. Arch Virol 151:607–615
- Kumar S, Tamura K, Nei M (2004) MEGA3: Integrated software for Molecular Evolutionary Genetics Analysis and sequence alignment. Brief Bioinform 5:150–163
- Kurita J, Nakajima K, Hirono I, Aoki T (2002) Complete genome sequencing of red seabream iridovirus (RSIV). Fisheries Sci 68:1113–1115
- Kwak KT, Gardner IA, Farver TB, Hedrick RP (2006) Rapid detection of white sturgeon iridovirus (WSIV) using a polymerase chain reaction (PCR) assay. Aquaculture 254:92–101
- Langdon JS, Humphrey JD (1987) Epizootic haematopoietic necrosis, a new viral disease in redfin perch, *Perca fluviatilis* L., in Australia. J Fish Dis 10:289–297
- Langdon JS, Humphrey JD, Williams LM, Hyatt AD, Westbury H (1986) First virus isolation from Australian fish: an iridovirus-like pathogen from redfin perch, *Perca fluviatilis* L. J Fish Dis 9:263–268
- Langelier Y, Bergeron S, Chabaud S, Lippens J, Guilbault C, Sasseville AMJ, Denis S, Mosser DD, Massie B (2002) The R1 subunit of herpes simplex virus ribonucleotide reductase protects cells against apoptosis at, or upstream of, caspase-8 activation. J Gen Virol 83:2779–2789
- Langland JO, Jacobs BL (2002) The role of the PKR-inhibitory genes E3L and K3L, in determining vaccinia virus host range. Virology 299:133–141
- Lembo D, Donalisio M, Hofer A, Cornaglia M, Brune W, Koszinowski U, Thelander L, Landolfo S (2004) The ribonucleotide reductase R1 homolog of murine cytomegalovirus is not a functional enzyme subunit but is required for pathogenesis. J Virol 78:4278–4288
- Leutenegger R (1967) Early events of *Sericesthis* iridescent virus infection in hemocytes of *Galleria mellonella* (L.). Virology 32:109–116
- Linley JR, Nielsen HT (1968a) Transmission of a mosquito iridescent virus in *Aedes taeniorhynchus*. I. Laboratory experiments. J Invertebr Pathol 12:7–16
- Linley JR, Nielsen HT (1968b) Transmission of a mosquito iridescent virus in *Aedes taeniorhynchus*. II. Experiments related to transmission in nature. J Invertebr Pathol 12:17–24
- López M, Rojas JC, Vandame R, Williams T (2002) Parasitoid-mediated transmission of an iridescent virus. J Invertebr Pathol 80:160–170
- Lu L, Zhou SY, Chen C, Weng SP, Chan SM, He JG (2005) Complete genome sequence analysis of an iridovirus isolated from the orange spotted grouper *Epinephelus coioides*. Virology 339:81–106
- Lua DT, Yasuike M, Hirono I, Aoki T (2005) Transcription program of red seabream iridovirus as revealed by DNA microarrays. J Virol 79:15151–15164
- Lua DT, Yasuike M, Hirono I, Kondo H, Aoki T (2007) Transcriptional profile of red seabream iridovirus in a fish model as revealed by DNA microarrays. Virus Genes 35:449–461

- Mahardika K, Zafran, Yamamoto A, Myazaki T (2004) Susceptibility of juvenile humpback grouper (*Cromileptes altivelis*) to grouper sleepy disease iridovirus (GSDIV). *Dis Aquat Org* 59:1–9
- Majji S, LaPatra S, Long SM, Bryan L, Sample R, Sinning A, Chinchar VG (2006) *Rana catesbeiana* virus Z (RCV-Z): a novel pathogenic ranavirus. *Dis Aquat Org* 73:1–11
- Maniero GD, Morales H, Gantress J, Robert J (2006) Generation of a long-lasting, protective, and neutralizing antibody response to the ranavirus FV3 by the frog *Xenopus*. *Dev Comp Immunol* 30:649–657
- Mao J, Tham TN, Gentry GA, Aubertin A, Chinchar VG (1996) Cloning, sequence analysis, and expression of the major capsid protein of the iridovirus frog virus 3. *Virology* 216:431–436
- Mao JH, Hedrick RP, Chinchar VG (1997) Molecular characterization, sequence analysis, and taxonomic position of newly isolated fish iridoviruses. *Virology* 229:212–220
- Mao J, Green DE, Fellers G, Chinchar VG (1999) Molecular characterization of iridoviruses isolated from sympatric amphibians and fish. *Virus Res* 63:45–62
- Marschang RE, Braun S, Becher P (2005) Isolation of a ranavirus from a gecko (*Uroplatus fimbriatus*). *J Zoo Wildlife Med* 36:295–300
- Marina CF, Arredondo-Jiménez J, Castillo A, Williams T (1999) Sublethal effects of iridovirus disease in a mosquito. *Oecologia* 119:383–388
- Marina CF, Arredondo-Jiménez JI, Ibarra JE, Fernández-Salas I, Williams T (2003a) Effects of an optical brightener and an abrasive on iridescent virus infection and development of *Aedes aegypti*. *Entomol Exp Appl* 109:155–161
- Marina CF, Ibarra JE, Arredondo-Jiménez JI, Fernández-Salas I, Liedo P, Williams T (2003b) Adverse effects of covert iridovirus infection on life history and demographic parameters of *Aedes aegypti*. *Entomol Exp Appl* 106:53–61
- Marina CF, Ibarra JE, Arredondo-Jiménez JI, Fernández-Salas I, Valle J, Williams T (2003c) Sublethal iridovirus disease of the mosquito *Aedes aegypti* is due to viral replication not cytotoxicity. *Med Vet Entomol* 17:187–194
- Marina CF, Fernández-Salas I, Ibarra JE, Arredondo-Jiménez JI, Valle J, Williams T (2005) Transmission dynamics of an iridescent virus in an experimental mosquito population: the role of host density. *Ecol Entomol* 30:376–382
- Martínez G, Christian P, Marina CF, Williams T (2003) Sensitivity of *Invertebrate iridescent virus 6* to organic solvents, detergents, enzymes and temperature treatment. *Virus Res* 91:249–254
- Mathieson WB, Lee PE (1981) Cytology and autoradiography of *Tipula* iridescent virus infection of insect suspension cell cultures. *J Ultrastruct Res* 74:59–68
- McMillan N, Kalkmakoff J (1994) RNA transcript mapping of the *Wiseana* iridescent virus genome. *Virus Res* 32:343–352
- McMillan NA, Davison S, Kalkmakoff J (1990) Comparison of the genomes of two sympatric iridescent viruses (types 9 and 16). *Arch Virol* 114:277–284
- Mendelson JR, Lips KR, Gagliardo RW, Rabb GB, Collins JP et al (2006) Confronting amphibian declines and extinctions. *Science* 313:48
- Miller DL, Rajeev S, Gray MJ, Baldwin CA (2007) Frog virus 3 infection, cultured American bullfrogs. *Emerg Inf Dis* 13:343
- Miller LK (1996) Insect viruses. In: Fields BN, Knipe DM, Howley PM (eds) *Fundamental virology*, Lippincott-Raven, Philadelphia, pp 401–424
- Moody NJG, Owens L (1994) Experimental demonstration of pathogenicity of a frog virus, bohle iridovirus, for a fish species, barramundi *Lates calcarifer*. *Dis Aquat Org* 18:95–102
- Moore JB, Smith GL (1992) Steroid hormone synthesis by vaccinia virus enzymes: a new type of virus virulence factor. *EMBO J* 11:1973–1980
- Morales HD, Robert J (2007) Characterization of primary and memory CD8 T cell responses against ranavirus (FV3) in *Xenopus laevis*. *J Virol* 81:2240–2248
- Mullens BA, Velten RK, Federici BA (1999) Iridescent virus infection in *Culicoides variipennis sonorensis* and interactions with the mermithid parasite *Heleidomermis magnapapula*. *J Invertebr Pathol* 73:231–233

- Murti KG, Goorha R (1989) Synthesis of FV3 proteins occurs on intermediate filament-bound polyribosomes. *Biol Cell* 65:205–214
- Murti KG, Goorha R (1990) Virus-cytoskeleton interaction during replication of frog virus 3. In: Darai G (ed) *Molecular biology of iridoviruses*, Kluwer, Boston, pp 137–162
- Murti KG, Goorha R, Klymkowsky MW (1988) A functional role for intermediate filaments in the formation of FV3 assembly sites. *Virology* 162:264–269
- Nakajima K, Kunita J (2005) Red sea bream iridoviral disease. *Uirusu* 55:115–125
- Nakajima K, Maeno Y (1998) Pathogenicity of red sea bream iridovirus and other fish iridoviruses to red sea bream. *Fish Pathol* 33:143–144
- Nakajima K, Inouye K, Sorimachi M (1998) Viral diseases in cultured marine fish in Japan. *Fish Pathol* 33:181–188
- Nakajima K, Maeno Y, Honda A, Yokoyama K, Tooriyama T, Manabe S (1999) Effectiveness of a vaccine against red sea bream iridovirus disease in a field trial test. *Dis Aquat Org* 36:73–75
- Nakajima K, Ito T, Kurita J, Kawakami H, Itano T, Fukuda Y, Aoi Y, Tooriyama, Manabe S (2002) Effectiveness of a vaccine against red sea bream iridoviral disease in various cultured marine fish under laboratory conditions. *Fish Pathol* 37:90–91
- Nalcacioglu R, Marks H, Vlaskovic JM, Demirbag Z, van Oers MM (2003) Promoter analysis of the *Chilo* iridescent virus DNA polymerase and major capsid protein genes. *Virology* 317:321–329
- Netherton C, Moffet K, Brooks E, Wileman T (2007) A guide to viral inclusions, membrane rearrangements, factories and viroplasm produced during virus replication. *Adv. Virus Res.* 70: 101–182
- Office International des Epizooties (2006) *Aquatic Animal Health Code*, 9th edn. OIE, Paris
- Ohba M (1975) Studies on the pathogenesis of *Chilo* iridescent virus. 3. Multiplication of CIV in the silkworm *Bombyx mori* L. and field insects. *Sci Bull Fac Agr Kyushu Univ* 30:71–81
- Ohba M, Aizawa K (1979) Multiplication of *Chilo* iridescent virus in noninsect arthropods. *J Invertebr Pathol* 33:278–283
- Ohba M, Aizawa K (1982) Failure of *Chilo* iridescent virus to replicate in the frog *Rana limnocharis* (in Japanese). *Proc Assoc Plant Protec Kyushu* 28:164–166
- Oliveros M, Garcia-Escudero R, Alejo A, Vinuela E, Salas ML, Salas J (1999) African swine fever virus dUTPase is a highly specific enzyme required for efficient replication in swine macrophages. *J Virol* 73:8934–8943
- Otto H, Reche PA, Bazan F, Dittmar K, Haa F, Koch-Nolte F (2005) *In silico* characterization of the family of PARP-like poly(ADP-ribosyl) transferases (pARTs). *BMC Genomics* 6:139
- Overholtzer M, Mailleaux AA, Mouneimne G, Normand G, Schnitt SJ, King RW, Cibas ES, Brugge JS (2007) A nonapoptotic cell death process, entosis, that occurs by cell-in-cell invasion. *Cell* 131:966–979
- Pallister J, Goldie S, Coupar B, Hyatt A (2005) Promoter activity in the 5' flanking regions of the Bohle iridovirus ICP18, ICP46 and major capsid protein genes. *Arch Virol* 150:1911–1919
- Pallister J, Goldie S, Coupar B, Shiell B, Michalski WP, Siddon N, and Hyatt A (2007) Bohle iridovirus as a vector for heterologous gene expression. *J Virol Methods* 146:419–423
- Pallister J, Gould A, Harrison D, Hyatt A, Jancovich J, Heine H (2007) Development of real-time PCR assays for the detection and differentiation of Australian and European ranaviruses. *J Fish Dis* 30:427–438
- Paul ER, Chitnis NS, Henderson CW, Kaul RJ, D'Costa SM, Bilimoria SL (2007) Induction of apoptosis by iridovirus virion protein extract. *Arch Virol* 152:1353–1364
- Paperna I, Vilenkin M, Alves de Matos AP (2001) Iridovirus infections in farm-reared tropical ornamental fish. *Dis Aquat Org* 48:17–25
- Pearman PB, Garner TWJ (2005) Susceptibility of Italian agile frog populations to an emerging strain of *Ranavirus* parallels population genetic diversity. *Ecol Lett* 8:401–408

- Pearman PB, Garner TWJ, Straub M, Greber UF (2004) Response of the Italian agile frog (*Rana latastei*) to a ranavirus, frog virus 3: a model for viral emergence in naïve populations. *J Wildlife Dis* 40:660–669
- Picco AM, Brunner JL, Collins JP (2007) Susceptibility of the endangered California tiger salamander, *Ambystoma californiense*, to ranavirus infection. *J Wildlife Dis* 43:286–290
- Pierce BE, Phillips PH, Jackson G (1991) Redfin virus (EHN) fish disease confirmed in South Australia. *SA Fish* 15:5–7
- Petrokovski S (1998) Identification of a virus intein and a possible variation in the protein-splicing reaction. *Curr Biol* 8:R634–R635
- Pozet F, Moussa A, Torhy C, de Kinkelin P (1992) Isolation and preliminary characterization of a pathogenic icosahedral deoxyribovirus from the catfish *Ictalurus melas*. *Dis Aquat Org* 14:35–42
- Radloff C, Juhl S, Vaia RA, Brunton J, Ward V, Kalmakoff J, Dokland T, Ha YH, Tomas EL (2005a) Bio-scaffolds for ordered nanostructures and metallo-dielectric nanoparticles. In: Lai WYC, Pau S, López OD (eds) *Nanofabrication: technologies, devices and applications*. Proc SPIE 5592:143–152
- Radloff C, Vaia RA, Brunton J, Bouwer GT, Ward VK (2005b) Metal nanoshell assembly on a virus bioscaffold. *Nano Lett* 5:1187–1191
- Raghow R, Granoff A (1979) Macromolecular synthesis in cells infected with frog virus 3. X. Inhibition of cell protein synthesis by heat-inactivated frog virus 3. *Virology* 98:319–327
- Raghow R, Granoff A (1983) Cell-free translation of FV3 mRNA: initiation factors from infected cells discriminate between early and late viral mRNAs. *J Biol Chem* 258:571–578
- Reading PC, Moore JB, Smith GL (2003) Steroid hormone synthesis by vaccinia virus suppresses the inflammatory response to infection. *J Exp Med* 197:1269–1278
- Reddacliff LA, Whittington RJ (1996) Pathology of epizootic haematopoietic necrosis virus (EHN) infection in rainbow trout (*Oncorhynchus mykiss* Walbaum) and redfin perch (*Perca fluviatilis* L.). *J Compar Pathol* 115:103–115
- Reyes A, Christian P, Valle J, Williams T (2004) Persistence of *Invertebrate iridescent virus 6* in soil. *BioContr* 49:433–440
- Ricou G (1975) Production de *Tipula paludosa* Meig en prairie en fonction de l'humidité du sol. *Rev Ecol Biol Sol* 12:69–89
- Robert J, Morales H, Buck W, Cohen N, Marr S, Gantress J (2005) Adaptive immunity and histopathology in frog virus 3-infected *Xenopus*. *Virology* 332:667–675
- Rodger H D, Kobs M, Macarthey A, Frerichs GN (1997) Systemic iridovirus infection in freshwater angelfish, *Pterophyllum scalare* (Lichtenstein). *J Fish Dis* 20:69–72
- Rojas S, Richards K, Jancovich JK, Davidson EW (2005) Influence of temperature on ranavirus infection in larval salamanders *Ambystoma tigrinum*. *Dis Aquat Org* 28:95–100
- Sample RC, Bryan L, Long S, Majji S, Hoskins G, Sinning A, Chinchar VG (2007) Inhibition of protein synthesis and virus replication by antisense morpholino oligonucleotides targeted to the major capsid protein, the 18 kDa immediate early protein, and a viral homologue of RNA polymerase II. *Virology* 358:311–320
- Schackelton LA, Parrish CR, Holmes EC (2006) Evolutionary basis of codon usage and nucleotide composition bias in vertebrate viruses. *J Mol Evol* 62:551–563
- Schock DM, Bollinger TK, Chinchar VG, Jancovich JK, Collins JP (2008) Experimental evidence that amphibian ranaviruses are multihost pathogens. *Copeia* 133–143
- Sieburth PJ, Carner GR (1987) Infectivity of an iridescent virus for larvae of *Anticarsia gemmatilis* (Lepidoptera: Noctuidae). *J Invertebr Pathol* 49:49–53
- Sikorowski PP, Tyson GE (1984) *Per os* transmission of iridescent virus of *Heliothis zea* (Lepidoptera: Noctuidae). *J Invertebr Pathol* 44:97–102
- Speare R, Smith JR (1992) An iridovirus-like agent isolated from the ornate burrowing frog *Limnodynastes ornatus* in northern Australia. *Dis Aquat Org* 14:51–57
- Song WJ, Qin QW, Qiu J, Huang CH, Wang F, Hew CL (2004) Functional genomics analysis of Singapore grouper iridovirus: complete sequence determination and proteomic analysis. *J Virol* 78:12576–12590

- Stasiak K, Demattei MV, Federici BA, Bigot Y (2000) Phylogenetic position of the *Diadromus pulchellus* ascovirus DNA polymerase among viruses with large double-stranded DNA genomes. *J Gen Virol* 81:3059–3072
- Stasiak K, Renault S, Demattei MV, Bigot Y, Federici BA (2003) Evidence for the evolution of ascoviruses from iridoviruses. *J Gen Virol* 84:2999–3009
- Stoltz DB (1971) The structure of icosahedral cytoplasmic deoxyriboviruses. *J Ultrastruc Res* 37:219–239
- Stoltz DB (1973) The structure of icosahedral cytoplasmic deoxyriboviruses II. An alternative model. *J Ultrastruc Res* 43:58–74
- Stoltz DB, Hilsenhoff WL, Stich HF (1968) A virus disease of *Chironomus plumosus*. *J Invertebr Pathol* 12:118–126
- Storfer A, Alfaro ME, Ridenhour BJ, Jancovich JK, Mech SG, Parris MJ, Collins JP (2007) Phylogenetic concordance analysis shows an emerging pathogen is novel and endemic. *Ecol Lett* 10:1075–1083
- Sudthongkong C, Miyata M, Miyazaki T (2001) Iridovirus disease in two ornamental tropical freshwater fishes: African lampeye and dwarf gourami. *Dis Aquat Org* 48:163–173
- Sudthongkong C, Miyata M, Miyazaki T (2002) Viral DNA sequences of genes encoding the ATPase and the major capsid protein of tropical iridovirus isolates which are pathogenic to fishes in Japan, South China Sea, and Southeast Asian countries. *Arch Virol* 147:2089–2109
- Sun W, Huang Y, Zhao Z, Gui JF, Zhang Q (2006) Characterization of the *Rana grylio* virus 3 β -hydroxysteroid dehydrogenase and its novel role in suppressing virus-induced cytopathic effect. *Biochem Biophys Res Comm* 351:44–50
- Tan S-L, Katze MG (1999) The emerging role of the interferon-induced PKR protein kinase as an apoptotic effector: A new face of death? *J Interferon Cytokine Res* 19:543–554
- Tan WGH, Barkman TJ, Chinchar VG, Essani K (2004) Comparative genomic analysis of frog virus 3, type species of the genus *Ranavirus* (family *Iridoviridae*). *Virology* 323:70–84
- Tanaka H, Sato K, Saito Y, Yamashita T, Agoh M, Okunishi J, Tachikawa E, Suzuki K (2003) Insect diapause-specific peptide from the leaf beetle has consensus with a putative iridovirus peptide. *Peptides* 24:1327–1333
- Tang KFJ, Redman RM, Pantoja CR, LeGroumellec M, Duraisamy P, Lightner DV (2007) Identification of an iridovirus in *Acetes erythraeus* (Sergestidae) and the development of *in situ* hybridization and PCR methods for its detection. *J Invert Pathol* 96:255–260
- Tapiovaara H, Olesen NJ, Linden J, Rimaila-Parnanen E, von Bonsdorff CH (1998) Isolation of an iridovirus from pike-perch *Stizostedion lucioperca*. *Dis Aquat Org* 32:185–193
- Tidona CA, Darai G (1997) The complete DNA sequence of lymphocystis disease virus. *Virology* 230:207–216
- Tonka T, Weiser J (2000) Iridovirus infection in mayfly larvae. *J Invertebr Pathol* 76:229–231
- Tortorella D, Gewurz BE, Furman MH, Schust DJ, Ploegh HL (2000) Viral subversion of the immune system. *Annu Rev Immunol* 18: 861–926
- Tsai CT, Lin CH, Chang CY (2007) Analysis of codon usage bias and base compositional constraints in iridovirus genomes. *Virus Res* 126:196–206
- Tweedel K, Granoff A (1968) Viruses and renal carcinoma of *Rana pipiens*. V. Effect of frog virus 3 on developing frog embryos and larvae. *J Natl Cancer Inst* 40:407–409
- Undeen AH, Fukuda T (1994) Effects of host resistance and injury on the susceptibility of *Aedes taeniorhynchus* to mosquito iridescent virus. *J Am Mosq Contr Assoc* 10:64–66
- Vetten HJ, Haenni A-L (2006) Taxon-specific suffixes for vernacular names. *Arch Virol* 151:1249–1250
- Wang YQ, Lu L, Weng SP, Huang JN, Chan SM, He JG (2007) Molecular epidemiology and phylogenetic analysis of a marine fish infectious spleen and kidney necrosis virus-like (ISKNV-like) virus. *Arch Virol* 152:763–773
- Ward VK, Kalmakoff J (1991) Invertebrate Iridoviridae. In: Kurstak E (ed) *Viruses of invertebrates*, Marcel Dekker, New York, pp 197–226

- Watson LR, Groff JM, Hedrick RP (1998) Replication and pathogenesis of white sturgeon iridovirus (WSIV) in experimentally infected white sturgeon *Acipenser transmontanus* juveniles and sturgeon cell lines. *Dis Aquat Org* 32:173–184
- Webby R, Kalmakoff J (1998) Sequence comparison of the major capsid protein gene from 18 diverse iridoviruses. *Arch Virol* 143:1949–1966
- Weissenberg R (1965) Fifty years of research on the lymphocystis virus disease of fishes (1914–1964). *Ann N Y Acad Sci* 126:362–374
- Werts C, Girardin SE, Philpott DJ (2006) TIR, CARD, and PYRIN: three domains for an antimicrobial triad. *Cell Death Differen* 13:798–815
- Whittington RJ, Reddacliff GL (1995) Influence of environmental temperature on experimental infection of redfin perch (*Perca fluviatilis*) and rainbow trout (*Oncorhynchus mykiss*) with epizootic haematopoietic necrosis virus, an Australian iridovirus. *Aust Vet J* 11:421–424
- Whittington RJ, Philbey A, Reddacliff GL, Macgowan AR (1994) Epidemiology of epizootic haematopoietic necrosis virus (EHNV) infection in farmed rainbow trout, *Oncorhynchus mykiss* (Walbaum): findings based on virus isolation, antigen capture ELISA and serology. *J Fish Dis* 17:205–218
- Whittington RJ, Kearns C, Hyatt AD, Hengstberger S, Rutzou T (1996) Spread of epizootic haematopoietic necrosis virus (EHNV) in redfin perch (*Perca fluviatilis*) in southern Australia. *Aust Vet J* 73:112–114
- Wileman T (2006) Aggresomes and autophagy generate sites for virus replication. *Science* 312:875–878
- Williams BRG (1999) PKR: a sentinel kinase for cellular stress. *Oncogene* 18:6112–6120
- Williams T (1993) Covert iridovirus infection of blackfly larvae. *Proc R Soc B* 251:225–230
- Williams T (1996) The iridoviruses. *Adv Virus Res* 46:347–412
- Williams T (1998) Invertebrate iridescent viruses. In: Miller LK, Ball LA (eds) *The insect viruses*, Plenum, New York, pp 31–68
- Williams T, Cory JS (1994) Proposals for a new classification of iridescent viruses. *J Gen Virol* 75:1291–1301
- Williams T, Hernández O (2006) Costs of cannibalism in the presence of an iridovirus pathogen of *Spodoptera frugiperda*. *Ecol Entomol* 31:106–113
- Williams T, Barbosa-Solomieu V, Chinchar VG (2005) A decade of advances in iridovirus research. *Adv Virus Res* 65:173–248
- Willis DB, Granoff A (1978) Macromolecular synthesis in cells infected by frog virus 3. IX. Two temporal classes of early viral RNA. *Virology* 86:443–453
- Willis DB, Granoff A (1980) Frog virus 3 DNA is heavily methylated at CpG sequences. *Virology* 107:250–257
- Willis DB, Granoff A (1985) Trans-activation of an immediate-early frog virus 3 promoter by a virion protein. *J Virol* 56:495–501
- Willis DB, Goorha R, Granoff A (1984) DNA methyltransferase induced by frog virus 3. *J Virol* 49:86–91
- Willis DB, Goorha R, Chinchar VG (1985) Macromolecular synthesis in cells infected by frog virus 3. *Curr Topics Microbiol Immunol* 116:77–106
- Willis DB, Thompson JP, Essani K, Goorha R (1989) Transcription of methylated viral DNA by eukaryotic RNA polymerase II. *Cell Biophys* 15:97–111
- Willis DB, Essani K, Goorha R, Thompson JP, Granoff A (1990a) Transcription of a methylated DNA virus. *Nucleic Acid Methylation*. UCLA Symp Mol Cell Biol 128:139–151
- Willis DB, Thompson JP, Beckman W (1990b) Transcription of frog virus 3. In: Darai G (ed) *Molecular biology of iridoviruses*, Kluwer, Boston, pp 173–186
- Wolf K (1988) *Fish viruses and fish viral diseases*. Cornell University Press, Ithaca.
- Wrigley NG (1969) An electron microscope study of the structure of *Sericesthis* iridescent virus. *J Gen Virol* 5:123–134
- Wrigley NG (1970) An electron microscope study of the structure of *Tipula* iridescent virus. *J Gen Virol* 6:169–173

- Xie J, Lu L, Deng M, Weng S, Zhu J, Wu Y, Gan L, Chan S-M, He J (2005) Inhibition of reporter gene and Iridovirus-tiger frog virus in fish cell by RNA interference. *Virology* 338:43–52
- Yan X, Olson NH, Van Etten JL, Bergoin M, Rossmann MG, Baker TS (2000) Structure and assembly of large lipid-containing dsDNA viruses. *Nature Struct Mol Biol* 7:101–103
- Youngusband HB, Lee PE (1969) Virus-cell studies of *Tipula* iridescent virus in *Galleria mellonella* (L.). I. Electron microscopy of infection and synthesis of *Tipula* iridescent virus in hemocytes. *Virology* 38:247–254
- Zemskov EA, Kang W, Maeda S (2000) Evidence for nucleic acid binding ability and nucleosome association of *Bombyx mori* nucleopolyhedrovirus BRO proteins. *J Virol* 74:6784–6789
- Zhang QY, Xiao F, Li ZQ, Gui JF, Mao J, Chinchar VG (2001) Characterization of an iridovirus from the cultured pig frog (*Rana grylio*) with lethal syndrome. *Dis Aquat Org* 48:27–36
- Zhang QY, Xiao F, Xie J, Li ZQ, Gui JF (2004) Complete genome sequence of lymphocystis disease virus isolated from China. *J Virol* 78:6982–6994
- Zhang QY, Zhao Z, Xiao F, Li ZQ, Gui JF (2006) Molecular characterization of three *Rana grylio* virus (RGV) isolates and *Paralichthys olivaceus* lymphocystis disease virus (LCDV-C) in iridoviruses. *Aquaculture* 251:1–10
- Zhang Y, Maley F, Maley GF, Duncan G, Dunigan DD, Van Etten JL (2007) Chloroviruses encode a bifunctional dCMP-dCTP deaminase that produces two key intermediates in dTTP formation. *J Virol* 81:7662–7671
- Zhao Z, Ke F, Gui JF, Zhang Q (2007) Characterization of an early gene encoding for dUTPase in *Rana grylio* virus. *Virus Res* 123:128–137
- Zheng FR, Sun XQ, Liu HZ, Zhang JX (2006) Study on the distribution and expression of a DNA vaccine against lymphocystis disease virus in Japanese flounder (*Paralichthys olivaceus*). *Aquaculture* 261:1128–1134
- Zupanovic Z, Lopez G, Hyatt A, Shiell BJ, Robinson AJ (1998a) An improved enzyme linked immunosorbent assay for detection of anti-ranavirus antibodies in the serum of the giant toad (*Bufo marinus*). *Dev Comp Immunol* 22:573–585
- Zupanovic Z, Musso C, Lopez C, Louriero CL, Hyatt AD, Hengstberger S, Robinson AJ (1998b) Isolation and characterization of iridoviruses from the giant toad *Bufo marinus* in Venezuela. *Dis Aquat Org* 33:1–9
- Zwillenberg LO, Wolf K (1968) Ultrastructure of lymphocystis virus. *J Virol* 2:393–399