

# FAST

AIRBUS  
TECHNICAL  
DIGEST

NUMBER 20  
DECEMBER 1996

100  
2000000  
MIA  
Date

Lufthansa  
ID Code: H  
Total (kg) 272  
Lufthansa  
Germany

# FAST

AIRBUS  
TECHNICAL  
DIGEST

NUMBER 20  
DECEMBER 1996

AIRBUS FLY-BY-WIRE AIRCRAFT AT A GLANCE  
**A PILOT'S FIRST VIEW**  
CAPTAIN CHRIS KRAHE

2

2ND A330/A340 TECHNICAL SYMPOSIUM  
4TH AIRBUS TRAINING SYMPOSIUM  
**CUSTOMER SERVICES EVENTS**

10

FLYING FAUNA AND FLORA  
DAVID SAXTON

11

COMING IN FROM THE COLD  
**IMPROVED WATER AND WASTE SYSTEM PROTECTION FROM FREEZING**  
LUC LEROY

16

AIRBUS CABIN AIR QUALITY  
**ONLY THE BEST!**  
MARTIN DECHOW

24

RESIDENT CUSTOMER SUPPORT  
REPRESENTATION

30

COMING IN FROM THE COLD  
**PART II**

32

*Cover photo - Sweet corn en route from Miami to Frankfurt*

The articles herein may be reprinted without permission except where copyright source is indicated, but with acknowledgement to Airbus Industrie. Articles which may be subject to ongoing review must have their accuracy verified prior to reprint. The statements made herein do not constitute an offer. They are based on the assumptions shown and are expressed in good faith. Where the supporting grounds for these statements are not shown, the Company will be pleased to explain the basis thereof.

© AIRBUS INDUSTRIE 1996

Publisher: Airbus Industrie Customer Services, 1 rond-point Maurice Bellonte, 31707 Blagnac Cedex, France  
Telephone +33 (5) 61 93 33 33, Telex AIRBU 530526F, Telefax +33 (5) 61 30 01 25  
Editor: Denis Dempster, Product Marketing  
Graphic design: Agnès Lacombe, Customer Services Marketing  
Photo-engraving: Passion Graphic, 60 boulevard Déodat de Séverac, 31027 Toulouse Cedex, France  
Printer: Escourbiac, 5 avenue Marcel Dassault, 31502 Toulouse Cedex, France

*This issue of FAST has been printed on paper produced without using chlorine, to reduce waste and help to conserve natural resources. 'Every little helps'.*



*For those pilots unfamiliar with the Airbus Industrie cockpit and system design philosophy, it is appropriate to look at a few issues which are perceived to be significant and may cause uncertainty. The sources for these notes are broad, and include feedback from more than 60 operators of A319s, A320s, A321s, A330s and A340s. Experience with cross crew qualification provides a further practical basis for the information.*

# AIRBUS FLY-BY-WIRE AIRCRAFT AT A GLANCE

## A PILOT'S FIRST VIEW

*Captain Chris Krahe  
Vice President Operational Flight Group  
Training and Flight Operations Support  
Airbus Industrie Customer Services Directorate*



*Pilots tend to be rather conservative in their outlook; a healthy quality in aviation. Because Airbus Industrie's fly-by-wire technology represents a significant new step in design philosophy, pilots have sometimes taken a cynical view of the new concepts involved, especially when not all the facts are available to them. The adjustments which were necessary with the advent of jet and swept wing transports are now a matter of history. The Airbus fly-by-wire family represents another step forward, requiring similar changes of outlook.*

*The new generation flight deck*



## EXPERIENCE

Fly-by-wire aircraft from Airbus Industrie have now been in airline service for more than seven years and over 700 are currently in service. More than 10,000 pilots from over 60 operators worldwide have followed the relevant training courses of Airbus Training or the airlines. In the meantime, over seven million flight hours and over four million flight cycles have been reached. The experience gained in the process of conversion to this technology has been well analysed.

Examples of A320 folklore include stories of incidents such as the “stuck-in-the-hold” and “unable to descend”. Extensive research has been carried out with many A320 operators which reveals no recorded evidence that these incidents ever occurred. Indeed, from a technical point of view, it is impossible to understand how either incident could have occurred because the basic modes, Heading and Vertical Speed, are always available. However, these unsubstantiated stories continue to circulate freely (Lufthansa has even seen fit to establish

a folder entitled “Specially Heard Insider Talk”, the initials of which summarise the content to some extent!).

## DESIGN OBJECTIVES

Airbus Industrie has set new standards in fuel-efficiency, performance, manufacturing quality, durability, ease of maintenance, environmental friendliness and comfort. While advanced aerodynamics could achieve some of these objectives, the brilliant speed and accuracy of the computer was harnessed wherever possible. Exact performance matching of power plants with airframe was critical for the A340 in order to avoid carrying extra weight generated by engines which provide excess thrust. (The twins have different design objectives, and considerable excess thrust to cover loss of 50% of it following an engine failure.) The use of lighter materials, load alleviation and flight envelope protection, were also advances which have been applied. Airbus Industrie has an outstanding reputation for building solid and durable airframes. The structures have

- A** **OVERHEAD PANEL**  
*System panels used more frequently are in lower part, centre row for engine related systems, flow scheme from bottom to top. Push-button controls, dark cockpit philosophy*
- B** **FLIGHT CONTROL UNIT (FCU)**  
*Engages autopilot and autothrust. Selection of modes HEADING, SPEED, MACH, ALTITUDE, VERTICAL SPEED, LOC, APPROACH*
- C** **EFIS CONTROL PANEL**  
*Select modes, ranges and options of Electronic Flight Instruments System, BARO:STD selection, master warning, master caution, autoland warning and sidestick priority lights*
- D** **PRIMARY FLIGHT DISPLAY (PFD)**  
*Engage status of Flight Director, autopilot and autothrust. Flight Mode Annunciation. Indication of ATTITUDE, AIRSPEED, ALTITUDE, VERTICAL SPEED, HEADING, ILS-DEVIATION, MARKER, RADIO ALTITUDE*
- E** **NAVIGATION DISPLAY (ND)**

- F** **ELECTRONIC CENTRALISED AIRCRAFT MONITORING SYSTEM - ECAM**  
**UPPER DISPLAY UNIT (DU)**  
*Engine primary indication, fuel quantity, slats/flaps position, warning/caution/memo message*  
**LOWER DISPLAY UNIT (DU)**  
*Aircraft system synoptics, status of systems*
- G** **MULTI-PURPOSE CONTROL DISPLAY UNIT (MCDU)**  
*Controls the Flight Management System (FMS) and the Central Fault and Display System (CFDS)*
- H** **SIDESTICK**
- I** **PULL-OUT WORKING TABLE**  
*In stowed position - Footrest pedals right and left*
- J** **FULL-SIZE PRINTER**
- K** **STAND-BY INSTRUMENTS**  
*Attitude, altitude, speed, DDRMI, compass*

been thoroughly ground tested and the data validated on flight test aircraft. They have the most efficient corrosion protection and their content of totally corrosion-free composites is the highest in the industry.

For passenger comfort, the “soft EPR/N1” cruise mode, minimises thrust fluctuations. On A330/A340, turbulence is damped by the CIT (control in turbulence) mode which uses elevator and rudder deflection to minimise the effects of an unstable atmosphere, and the MLA (manoeuvre load alleviation) function which uses ailerons and spoilers to minimise wing deflection under load. Cabin air is passed through an optional ozone converter to reduce “red-eye” on ultra long range flights, and the A340 engine/airframe combination produces the quietest cockpit and cabin in the sky.

### COCKPIT GENERAL DESIGN

Airbus Industrie has entrusted world famous industrial designers with the objective of providing the flight crew with a pleasant, comfortable and modern working place. The cockpit colour scheme, light blue for panels, dark blue for linings and working surfaces, black for handles such as sidestick, thrust levers, flap handle etc. and grey for knobs and rotary selectors has been developed according to ergonomic criteria and applied throughout. Special attention has been given to cockpit lighting. Halogen type bulbs are used, dimmable in steps or stepless, where appropriate. Large surface dome lights comprising several bulbs and integrated emergency lights provide shadow-free general illumination. Console lights and lighting below the pilots’ seats illuminate the floor area. The pilot seats have been equally redesigned with optional headrests and multiple adjustment facilities. The seat cover tissue is the same material as used in Porsche cars.

Air-conditioning flow has been carefully studied. The air is provided through various outlets that can be controlled according to any demand, with a draft-free airflow.

Fasteners, nuts and bolts normally visible on the instrument panels have been covered by lightweight molded sheet material for a clean, calm and homogeneous aspect.

The pull-out folding table is very convenient for paperwork or when eating a meal. Ample stowage space is provided for coats and on-board documentation with space to be customised for company items.

Turning now to the instrument panels, several design principles have been applied throughout :

- Lights-out concept.

- Adherence to colour coding (white, blue, amber, red, green, magenta).
- Need to show concept (ECAM normal mode).
- Paperless aircraft (ECAM abnormal mode).

### THE COMPUTERS

As is well known, transport aircraft preceding A319/A320/A321/A330/A340 fly-by-wire aircraft, used computers to drive FMS, EFIS, autopilot, manage navigation, and enable automatic approaches to be flown safely. Such technology was to some extent “add-on”, rather than “built-in”, as the rest of the aircraft usually functioned conventionally.

The designers of Airbus Industrie fly-by-wire aircraft have taken the use of computers a step further by internetting the computers and systems. Deliberately, *different manufacturers, different hardware and different software formats* have been employed in order to eliminate the potential for common faults. Software development follows well established international rules and Airworthiness Regulations including rigorous testing and modification tracking procedures. When studying the aircraft, it will become apparent that every major system has some sort of interaction with other systems or flight situations (e.g. changes to the condition of the hydraulic and electrical systems directly effect flight control laws).

### FLIGHT PHASES

Performance and vertical and lateral navigation obviously depend on the phase of flight. The Flight Management and Guidance System (FMGS) computers respond to changes of flight phase automatically, altering performance /speed targets to fit with the phase of flight. ECAM information is presented in a pre-set sequence from start-up to shut-down, as a function of each flight phase. Crew awareness of what flight phase the computers are in is important.

### THE SIDESTICK FLY-BY-WIRE

#### History

From the early days of aviation until the times of the Stratocruiser and Super Guppy, flying an airplane was often hard physical work. Battling against the elements, pilots had to navigate their flying machines by manually operating control cables that were connected to the surfaces of flaps, ailerons, elevators and rudders. Larger and faster aircraft required more than human strength to control them. Powerful hydraulic sys-

tems which the pilot operated via the controls, cables and pulleys were introduced. In the early 1980s, however, secondary flight control design began to utilise electrical signals from the control lever via computers to the hydraulic actuators of the surfaces. The new fly-by-wire system extended this technology to primary flight controls. The conventional yoke was no longer needed because the flight deck commands were transmitted electronically. It was replaced by a smaller lever, the *sidestick*. The new system reduced the aircraft's weight, the mechanical complexity and cut costs. For the pilot, the system enhances advantages mainly in terms of precision, safety and ergonomics.

Through the mediating role of the computers which know the full scope of the technical and aerodynamic capabilities of the aircraft, the pilot can exploit these to the full without the risk of exceeding the flight envelope. The envelope part of the fly-by-wire computers is pre-programmed to limit aircraft attitudes (in *Normal Law*) to 67 degrees of bank (2.5G in level flight) and usually +30 to -15 degrees of pitch. Violations of speed limits ( $V_{mo}/M_{mo}$ , low speeds), are also protected against, regardless of pilot sidestick input.

### Technical

Of all alternatives, thought of or tried out in a long development process, the designers, together with experienced airline and test-pilots, retained the sidestick as it is today. The sidestick provides no direct feedback through the grip. Feedback is indirect via the results of the application. The sidestick is moved against spring pressure and damping elements. The designers wanted to avoid complex back-driven feedback systems, sidestick linking, jam or feedback monitoring devices, and control-splitting systems, all of which increase friction, weight, complexity and cost and finally reduce system reliability.

The sidestick has no direct mechanical connection to the control surface. The means of transmission from sidestick to computers to control surfaces is via shielded low impedance electric cables. As part of the A320 European and US certification process, the system was bombarded by radiation from military radars and the aircraft was deliberately flown into multiple lightning strikes. There are no recorded cases in airline service where electromagnetic interference has affected the A319, A320, A321, A330 or A340 fly-by-wire systems. In fact, it is understood that the US FAA electromagnetic protection standards for fly-by-wire transports have now been reduced.

### CONVENTIONAL FLYING CONTROLS

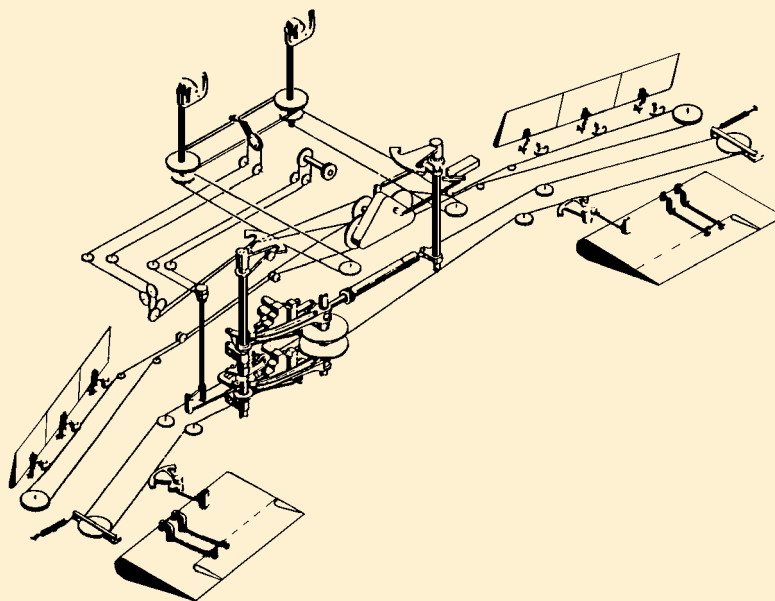

### MODERN FLYING CONTROLS

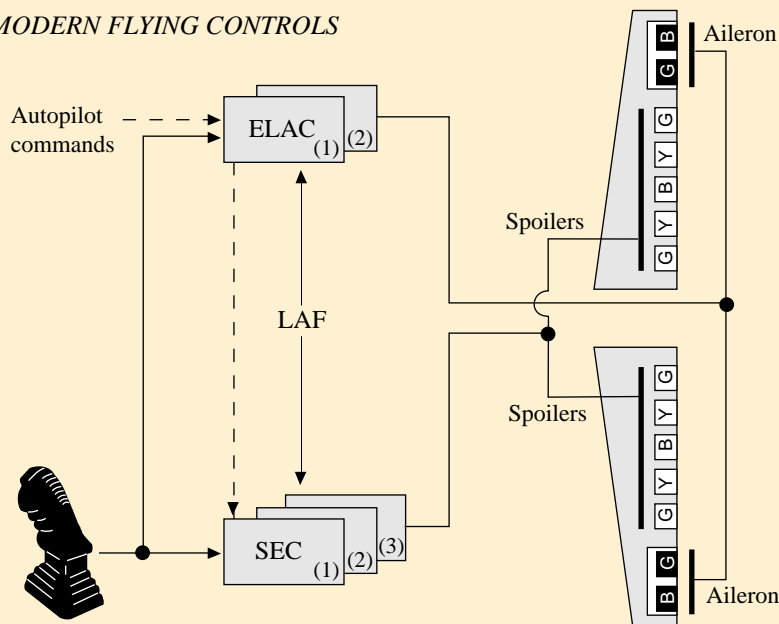

LAF Load alleviation function  
 ELAC Elevator and aileron computer  
 SEC Spoiler and elevator computer

Hydraulic:  
 B Blue system  
 G Green system  
 Y Yellow system

If an incapacitated pilot should freeze his sidestick into full deflection, the other pilot simply presses his instinctive take-over pushbutton on his sidestick and immediately takes control. After holding the button depressed for 30 seconds, he can lock out the other sidestick completely. However, the last pilot to press and hold this button always takes control.

If both pilots make a sidestick input together, the result is the algebraic sum of both inputs. It is, therefore, important in the training environment to give priority to the other cues which mea-

sure trainee inputs, such as the visual cues used in the past. It is important for pilots to be clear about the allocation of control.

### *Control in Pitch*

Control is via the computers. Throughout the flight, the elevators move under the control of the flight computers with no pilot input needed to maintain a 1.0G flight.

In **normal** or **alternate law** the sidestick does not select a control deflection or attitude directly, as would be the case with a conventional aircraft, and the elevator deflection is not proportional to sidestick movement. A fore or aft sidestick application selects “G”. If a pitch input is made and held, the aircraft will pitch at a constant G until the flight envelope limits are met.

Moving the sidestick back creates a demand greater than 1.0G, and forward creates a demand less than 1.0G. When the sidestick is released (stickfree), the demand fed to the computers is to maintain flight at 1.0G (relative to the earth). One can, therefore, consider a selected input as a selected vector through space, which the computers will maintain, even through turbulence. There is no need to ride the sidestick as may be done with conventional controls.

In **normal law** there is no requirement to trim. Without autotrim, the fly-by-wire aircraft would be no different from a conventional aircraft in that as it slows down, it would try to maintain its in-trim speed, and as a result would pitch nose down, losing altitude. However, in normal law, the flight control computers now detect a pitch-down tendency as a G less than 1.0G and so cause the elevators to move up, returning the aircraft to flight at 1.0G. As a result, the aircraft will decelerate in level flight with no pilot input, maintaining 1.0G to the earth and continuously adjusting the trim until it reaches the flight envelope protection.

### *Control in Roll*

In **normal law** in roll, the sidestick demands roll rate. If the sidestick input in roll is held, the aircraft will roll until the flight envelope limits are met. This is apparent during a crosswind take-off, if a normal control input is made into wind and held after rotation. While on the runway, the sidestick applies aileron directly, and then when airborne as the flight control laws blend in, the aircraft will roll into the crosswind at a rate proportional to the sidestick deflection. Up to 33 degrees of bank, the aircraft is automatically trimmed and maintains level flight (no nose drop). Above

33 degrees bank, when releasing the stick, it returns to 33 degrees. To perform a steep turn at 45 degrees or 60 degrees of bank, the stick must be held into the turn and pulled in order to maintain level flight.

In **alternate law** in roll, the sidestick commands control surfaces directly, which is virtually the same as a conventional aircraft. It may be found that alternate law roll is rather more sensitive than normal law.

### *The Sidestick - practical*

It takes most pilots 10 minutes (i.e. one traffic pattern) to get used to it. It enables the aircraft to be flown more precisely, and requires less effort.

The lack of “through-stick” feedback is a much more minor issue in practice than might be expected. Alternative feedback cues are abundant and are quickly substituted for the traditional feel.

The automatic trim function is a delight once experienced and further improves precision flying.

## THRUST MANAGEMENT

FADEC (Full Authority Digital Engine Control) driven engines need electrical signals for thrust control. With this, the weak points of conventional autothrottles could be eliminated (GO-levers, backdrives, clutches with spurious engine retards on take-offs, jams or run-aways). In manual thrust, the pilot moves the thrust levers between idle and full thrust as usual. In autothrust, the thrust levers are set to a fixed position which defines the maximum thrust available. No thrust rating panel is required. Whether in manual or autothrust, speed and power changes are monitored via N1, indicated speed and speed trend as on any aircraft. Compared to the old system, this new system has a reliability which is increased by an order of magnitude.

It may take a few minutes to get used to the thrust levers. It is a training issue and experience shows, all pilots master the thrust levers after some practice in the simulator.

## THRUST LEVERS

- In manual thrust, the thrust levers are handled as on any other aircraft. They can be set to 4 gates (see Figure 1). These gates define the maximum thrust available up to that gate (TOGA, FLEX/MCT, CLIMB (CLB) and IDLE).
- Automatic thrust is armed when the thrust levers are moved forward of the CLB gate (TOGA or FLEX on take-off with Flight Director on).

- At thrust reduction to CLB (i.e. when the thrust levers are pulled back from TOGA or FLEX to the CLB gate), autothrust mode engages.
- In autothrust, the cue of thrust lever movement is not available. Engine indications, indicated speed and speed trend are used as unambiguous thrust cues.
- Noise cues are of limited value except at high thrust settings (the A340 is especially quiet).
- These aircraft are extremely visual (see later paragraph on FMGS). The whole package of cues needs to be monitored. Once this becomes familiar, and the cues presented are understood, the thrust management task is a simple one.
- Manual thrust is always available.
- With autothrust engaged, and the thrust levers at a gate, disconnection of the autothrust would signal the FADEC to provide the thrust equivalent to the thrust lever angle (TLA).
- Pushing the thrust levers fully forward to the stop (TOGA gate) always provides maximum thrust available.

### ALPHA FLOOR

Alpha Floor is a low speed protection (in *normal law*) which is purely an autothrust mode. When activated, it provides TOGA thrust. As the aircraft decelerates into the alpha protection range, the Alpha Floor is activated, even if the autothrust is disengaged. Activation is roughly proportional to the rate of deceleration.

Alpha Floor is inhibited :

- below 100 feet radio Altitude,
- if autothrust unserviceable,
- following double engine failure on an A340 (or one engine out on the twins),
- following certain system/auto flight failures,
- above Mach 0.53.

Subject to the above, at low speeds, if a rapid avoidance manoeuvre is required to avoid terrain, windshear or another aircraft, **it is safe to rapidly pull the sidestick fully aft and/or bank and hold it there. The aircraft will pitch up to max Alpha, engage TOGA thrust and climb away. Such precise manoeuvring around the low speed edge of the flight envelope is virtually not possible in any conventional aircraft.**

### ONE ENGINE INOPERATIVE FLIGHT

If an engine fails, the triangle at the top of the PFD horizon will divide (see Figure 2). The lower resulting trapezoid changes to blue and will move out in a similar sense to a conventional slip ball, indicating pilot rudder demand in ex-

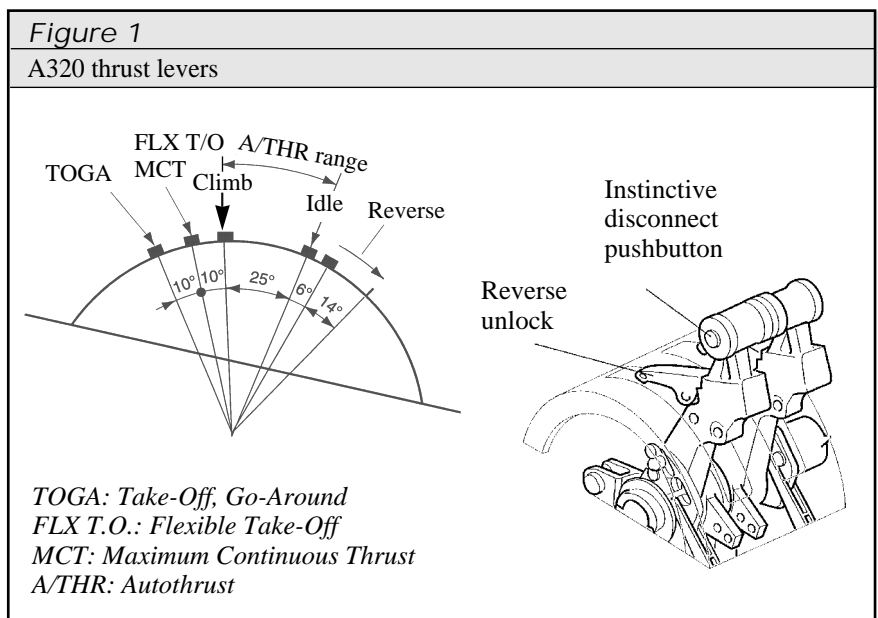

actly the same way. However, the function is significantly different from the ball in that the centering of the trapezoid (Beta Target) will provide maximum performance with minimum drag.

If no rudder action is taken to centre the Beta Target, like a conventional aircraft, roll will occur towards the dead engine. However, unlike a conventional aircraft, with stick free (no sidestick roll input), the flight control laws will detect the roll and apply aileron

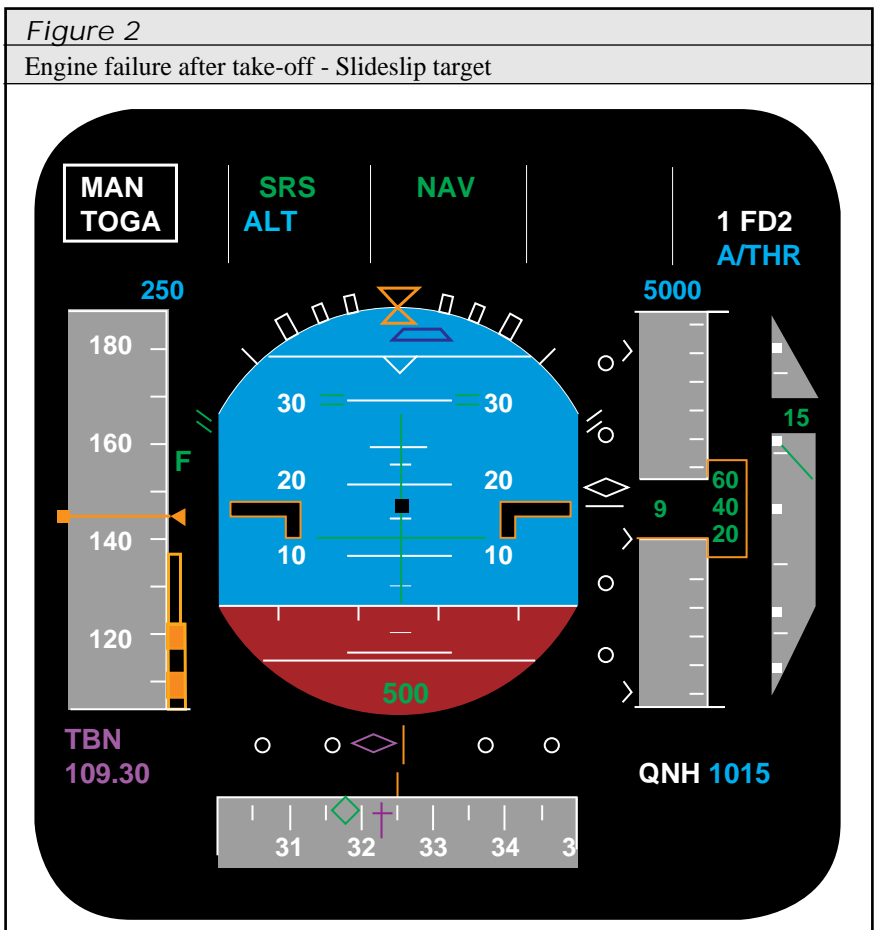



and spoiler to stop the roll. The rate of roll will depend on the severity of the thrust loss. In the worst case, the roll will stabilise between 7-9 degrees bank angle, leading to a slow heading drift of about 0.5 degree per second, without any sidestick roll input or rudder input.

**FLIGHT MANAGEMENT AND GUIDANCE SYSTEM**

Honeywell programme the Multi-purpose Control and Display Unit (MCDU) to operate the Flight Management and Guidance System (FMGS) to differing aircraft manufacturer requirements. The Airbus design philosophy of MCDU management differs in some significant ways from other fits, such as the B747 or MD11.

A pilot not having used a Flight Management System before should not attach excessive importance to it. It is important, as a *long-term* (planning) management tool for performance, lateral and vertical navigation, but *short-term* changes are made on the Flight Control Unit (FCU) on the glareshield panel, where the basic modes of Heading and Vertical Speed are set at any time, as with any other autopilot. The FMGS focuses many tasks which traditionally were scattered via the keyboard and screen (MCDU) into the computers and autopilot. It represents a major pilot interface with the aircraft, but it is *not vital* and must not become too dominant in pilot activities, especially in terminal areas. The MCDU is a compelling tool, however in flight, only one pilot at a time should be working (head down) on the keyboard. Strict adherence to task sharing and crew

resource management principles are essential. The continued monitoring of raw data (needles and DME) is always a protection from inaccurate information.

Getting used to the MCDU is accelerated by an effective “freeplay trainer” (see Figure 3) and exposure. There should be plenty of both. As knowledge is built up, the pilot can easily become bogged down by trivia, and lose the *big picture*. The pilot must always ask himself:

- *What is the aircraft doing and where is it?*
- *What is the phase of flight?*
- *Are the computers right?*
- *How does the raw data compare?*
- *What happens next, and what must be planned for?*
- *Are tasks being shared between both pilots efficiently?*

In order to help the pilot to see what the computers are instructing the aircraft to do, there is a Flight Mode Annunciator (FMA) on the top part of the Primary Flight Display (PFD), and targets indicated on ALT, SPEED and HEADING scales. From the beginning, these should be thought of as essential *instrument scan targets*. The FMA is the feedback from the computers, it closes the loop and will display the paramount feedback. To maintain total awareness, the scan should continue from the FMA to cover the Navigation Display (ND), and the upper display (ECAM) memo area.

**TWO PILOT OPERATIONS**

Many pilots have already operated as part of a two man crew. One of the primary objectives of Airbus technology has been to design the flight deck for ease of operation to facilitate two-crew functions more safely than before. However, this does not detract from the fact that effective task sharing and crew resource management are vital ingredients of two-pilot operations, especially in high workload areas and abnormal situations. This is rarely seen more than during ECAM actions resulting from an abnormal situation. This can be anticipated by reviewing attitudes towards effective communication, listening, reviewing, and the establishment of priorities.

**CCQ MIXED FLEET FLYING**

Whereas A319, A320, A321 are covered by the same type rating, the other family members A330 and A340 each have their own type rating. However, all these Airbus fly-by-wire aircraft share a lot of commonality. Following the FAA Advisory Circular AC 120-53,

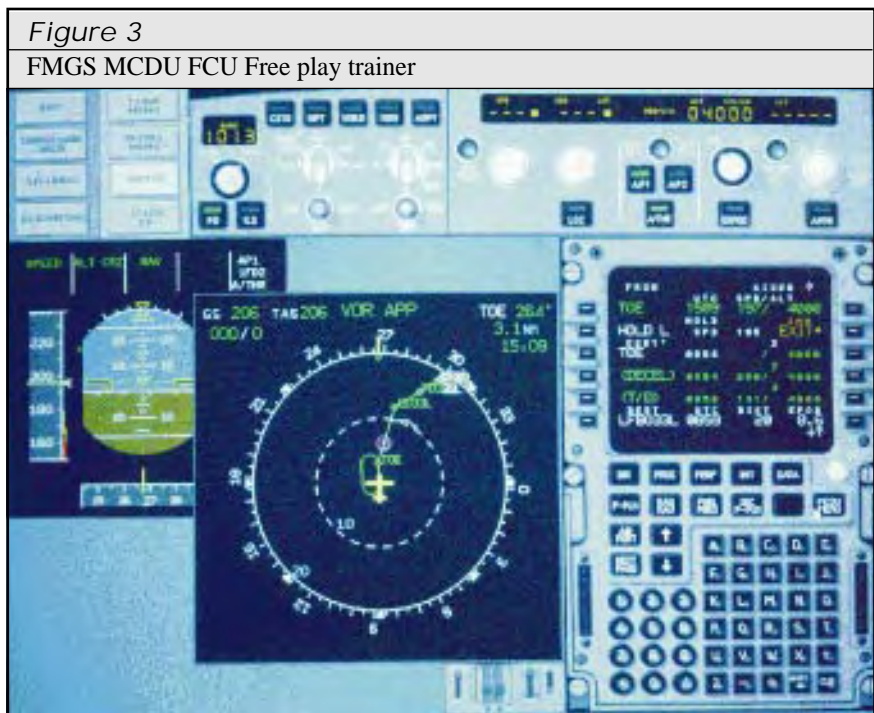

Figure 3

FMGS MCDU FCU Free play trainer

Airbus Training has set up short difference training courses to obtain the new type rating when the applicant holds one of the family as *base* aircraft. This is known as Cross Crew Qualification (CCQ).

- A320 → A330: 11 days CCQ course
- A320 → A340: 13 days CCQ course
- A340 → A320: 11 days CCQ course
- A330 → A340: 3 days CCQ course
- A340 → A330: 1 days CCQ course

It is, of course, necessary that the airworthiness authority of the operator approves the CCQ combinations in question, which is the case already for a number of countries such as France, Austria, UK, Germany, USA and Canada. Concerning Mixed Fleet Flying, there has been first experience gained by some operators, such as Lufthansa (A320 and A340). The German airworthiness authority (LBA) has laid down rules concerning:

- experience on “base” aircraft,
- practice on “new” aircraft,
- refresher training,
- proficiency checks.

A strong safety argument in favour of mixed fleet flying, accepted by the German authorities is, that dedicated long haul flying reduces handling skills, which can be regained through a combination of long and short haul flying. There are multiple and obvious attractive features of such mixed flying cited by the crews who practice it.

With certain airlines, industrial and labour contracts prohibit mixed fleet flying - reasons which have of course nothing to do with the technical/proficiency issue.

The traditional arguments against mixed fleet flying, such as differing

feel, differing eye height (A320 - A330/A340) and differing numbers of engines (A330/A340) can be understood, we believe, if one applies them to existing technology. However, with a thorough understanding of the generic philosophy of the Airbus fly-by-wire aircraft, it will be realised that :

- Aircraft response to control inputs is very alike between A320, A330 and A340 aircraft,
- Eye height is not an issue for those airlines who have practiced A320/A340 mixed fleet flying for some time.
- Engine failure, in terms of aircraft handling, whether on the A320 family, A330 or A340, becomes a non-threatening event, where unusual attitudes cannot result from rudder mishandling (see paragraph *One Engine Inoperative Flight*). A large box appears around the failed engine's parameters on ECAM, and if an engine fire is involved, a repeater light adjacent to the engine master switch confirms correct engine selection during the failure drill.
- The identification of which engine to shut down is a question of proper crew coordination, required for any abnormal situation. Heavy emphasis during conversion and recurrent training will address this issue.

The current mixed fleet flying practice provides for a minimum period on the first variant, followed by a short Cross Crew Qualification course and a minimum period of the second variant. Following this process, release to full mixed fleet flying operations is envisaged, subject to the maintenance of minimum currency requirements and aircraft ratings of both variants.

## CONCLUSION

As can be seen from these notes, changing to the A319/A320/A321 or A330 from other types (other than A340) will require some change of operational philosophy. These aircraft can be flown precisely and smoothly with little effort, and can, therefore, create a sense of considerable satisfaction. However, under extreme conditions when, for example, severe weather and abnormalities combine, it is most important to be aware of the differences. Under stress, reversion to certain well-ingrained pilot instincts, such as *riding the controls*, is not helpful in any fly-by-wire aircraft. In order to establish the new skills necessary, it is important to *unlearn* some traditional ones. Understanding the importance of this, and maintaining an open mind, are important attitudes to bring to training courses.

Airbus aircraft are products of large commitments of research, development and testing by some of the best aeronautical designers and engineers from four countries. The new generation aircraft (A319 through A330/A340) have now accumulated large amounts of in-service experience over seven million flight hours. They are quality products. Pilots flying these aircraft will find that they have embarked on a most enjoyable and professionally rewarding part of their aviation careers. ■

## THE 2ND A330/A340 TECHNICAL SYMPOSIUM

11th to 15th of November 1996, Dublin

*Just happened...*

Over two hundred representatives from twenty-eight operators, seventy-three suppliers and Airbus Industrie attended the second A330/A340 Technical Symposium in Dublin. The conference was chaired by Jean-Pierre Samat, A330/A340 Programme Director, Engineering and Technical Support, Customer Services Directorate.

Twenty-five formal presentations were organised in two sessions which ran in parallel in two different rooms. All these presentations were made using a computerised projection which pleased the participants in terms of comfort and graphic quality. These formal presentations covered the principal questions asked by the operators prior to the meeting. In addition, writ-

ten answers to remaining questions were given in the documentation provided to each participant.

This meeting allowed our customers to know better all the processes being developed by Airbus Industrie to improve in-service reliability and maintenance.

Following the tradition, Airbus Industrie distributed Awards for operational excellence to Air Portugal for A340 and Thai Airways International for the A330. These Awards for operational excellence correspond to a quantification of the airline operation based on operational interruption rate, duration of the flight, etc... The awards for highest aircraft utilisation went to Virgin Atlantic for A340 and Aer Lingus for A330. ■

*Mr Roger LECOMTE  
Airbus Industrie VP Engineering and  
Technical Support, and the happy  
recipients with their awards:  
(from left to right)*

*Mr Larry STANLEY - AER LINGUS  
Deputy Chief Executive*

*Mr Jorge SOBRAL - AIR PORTUGAL  
General Director  
Maintenance and Engineering*

*Peter WOOLLACOTT - VIRGIN  
Head of Development Airbus Group*

*Wiboon KULARTYUT  
THAI AIRWAYS INTERNATIONAL  
Avionics Engineer*



*... and coming soon*

## THE 4TH AIRBUS TRAINING SYMPOSIUM

5th to 9th of May 1997, Barcelona

- Lectures
- Airline Panels
- Workshops
- Caucus sessions
- Show room
- Flight Crew training
- Maintenance training
- Cabin Crew training
- Performance Engineers training
- Human Factors
- Regulatory aspects

An excellent opportunity for Airbus operators' Training Directors and Managers to share their experience, to meet with other airline's training specialists, Airworthiness Authorities... and Airbus Industrie staff.

Invitations to attend this event are presently being sent by Airbus Industrie's Training and Flight Operations Support Division. ■

**A** vailability of fresh fruit and fresh flowers, many of them exotic, all the year round is now so common-place that we give little thought to the effort involved in transporting South African flowers daily to Stuttgart.

Without aircraft it would not be possible. And it is not possible on all aircraft. Only those which have the cargo compartments cor-

FLYING

FAUNA

FLORA



rectly ventilated and air conditioned can safely carry great varieties of vegetables, flowers and livestock.

Not all airlines carry these products so not all aircraft need to be configured to carry them.

Hence the reason why aircraft manufacturers offer them as options. All Airbus Industrie aircraft can be configured to carry live stock and perishable goods.



by David Saxton, Senior Engineer  
Ground Handling and Special Transport  
Airbus Industrie Engineering Directorate



*Perishable goods label*

## TRANSPORT OF PERISHABLE GOODS

Under Perishable Goods most people think of salad produce and, perhaps, strawberries, but these items cover just a very small part of what the air cargo industry transport as Perishables. The list goes far beyond just lettuce and tomatoes, and includes apples, pears, melons, cut flowers, fresh fish, meat, pharmaceuticals and much more.

The transport of perishable goods is one of the fastest growing segments of the air transport industry, with freight forwarders increasingly resorting to air transport for the shipment of these high-value products.

The extra cost of air transport is offset by the reduced travelling time, resulting in the produce reaching the market in a fresher condition. To achieve this result careful planning and professional handling of the produce play a crucial role.

In the transport of such high-value products the watch words have to be "Time is money"; lost time and inadequate planning can mean lost money. Much time can be saved by having the necessary export/import documentation correctly complete before the products arrive at the airport for despatch.

Many major airports either already have or are rapidly developing special departments to handling exclusively the specific requirements of perishable goods. Although speed is essential in moving the product as quickly as possible from the farm to the market, the compatibility between the various products is also important.

In order that the products remain in optimum condition for the market, it is necessary to maintain a constant temperature during transit in the range 2 °C to 10 °C, depending on the product con-

cerned. A high relative humidity level is also required - up to 90% for some products.

Too low a temperature will permanently change the texture of some products, so called chilling injury. Typical symptoms of such injury may be discoloration, off-flavours and a decrease in the ability to resist decay, thus reducing their resale value.

Pre-cooled goods are generally transported in containers, using either purpose-built insulated containers, or using one of the commercially available "cool blankets" to maintain temperatures within the container. Alternatively, goods may be transported on standard pallets. In this case the required temperature is maintained in the cargo compartment either by the use of dry ice contained within the consignment, or by using the aircraft's ventilation system. Where higher temperatures are required, an optional heating system is also available.

The cargo compartments of Airbus Industrie's wide-body aircraft are fitted with semi-automatic cargo loading systems which accept a comprehensive range of pallets and containers. The Airbus Industrie standard-body aircraft can also be fitted with a semi-automatic cargo loading system.

The basic versions of Airbus Industrie's aircraft are not provided with ventilation nor heating, but a range of options are available to provide a suitable environment for the safe transport of perishable goods.

In addition to the temperature and relative humidity requirements of the various products, the vapours given off by some products can be harmful to other products, or may cause premature ripening. For example, apples - in common with a range of other fruit - give off ethylene gas which is detrimental to lettuce, carrots and some types of flowers. Also products that should retain a green colour during transit, such as bananas and peppers, should not be transported with ethylene producers.

Odours given off by apples, citrus fruits, onions, pineapples and fish are readily absorbed by dairy produce, eggs, meats and nuts. Apples and pears may acquire an earthy taste if transported together with potatoes.

As will be appreciated from the above, the particular requirements of the various products can limit the possibility to carry mixed loads in one cargo compartment, and careful selection is required when making-up loads of perishable goods. This problem can be made all the more difficult when a planned load does not arrive on time.

To assist operators with the transport of perishable goods, IATA are currently preparing a perishable goods manual.

*Insulated LD3 "cooltainer"*

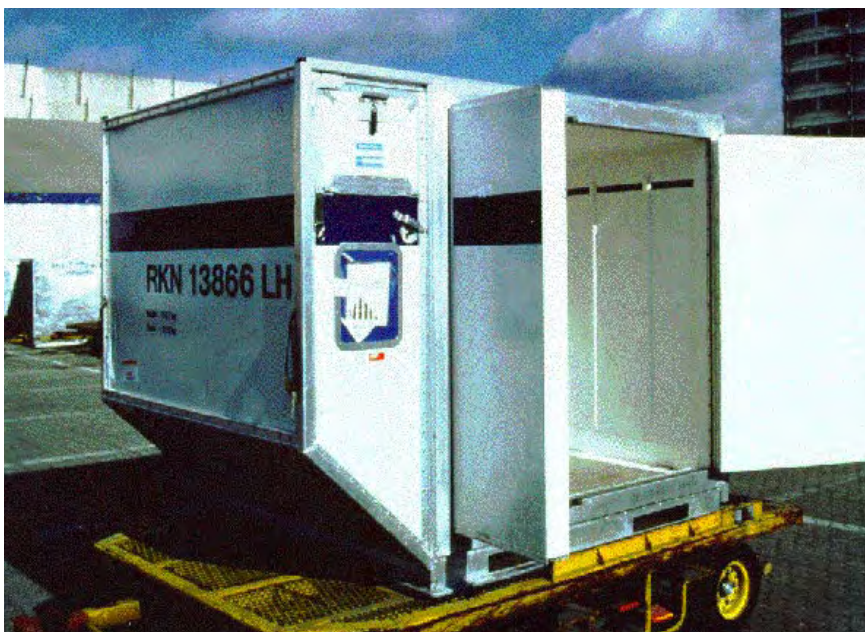

### SOME TOPICAL TIPS:

Ensure load compatibility and required transit temperatures. Ask:

- does one or more of the products give off ethylene gas or odours?
- does one or more of the products absorb odours?

#### Examples:

##### ● Ethylene Producers

Typically apples, avocados, bananas, honeydew melons, peaches, pears, plums, tomatoes.

##### ● Ethylene Sensitive

Typically carrots, lettuce, some flowers, celery, some nursery stock, all products that should keep a green colour.

##### ● Odour Producers

Typically apples, citrus fruit, pineapple, onions, potatoes, carrots, fish.

##### ● Odour Sensitive

Typically meats, eggs, dairy produce, nuts, celery.

### LIVE ANIMAL TRANSPORT

The transport of live animals has become a highly emotive issue in recent years with demonstrations against the shipment of sheep and calves, but farm animals are not the only animals that travel around the world.

The quantity and type of animals that are transported by air, range from Aunt Emma's pet poodle who is being taken with her on holiday, through horses that are travelling to a race meeting or a show-jumping event, a load of pedigree breeding animals destined to set-up a new herd in a third-world country and on to exotics such as a panda going to a new home, or returning to an old one.

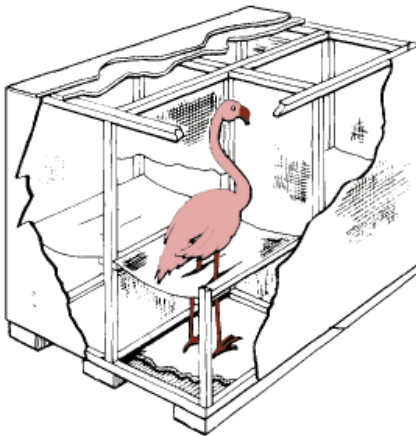

Concern for the welfare of animals on board aircraft begins long before the animals even arrive at the airport. The SAE specification AIR1600 "Conditions in Cargo Compartments for Live Animal Transport" sets out the requirements which the airframe manufacturer has to follow to ensure that a suitable environment can be provided

in the cargo compartment to permit the safe transport of live animals. This specification contains a table which lists the recommended temperature range in the cargo compartment for the various types of animals.

Airbus Industrie is currently sponsoring the regular 5-year review of this specification, with Boeing as co-sponsor.

This concern for the welfare of the animals continues into commercial service through the IATA Live Animals Board, a trade association representing over 250 commercial airlines worldwide, which has published the "IATA Live Animals Regulations" as an industry standard for transporting animals. These regulations are updated annually and can be considered as the "bible" for the transport of live animals.

The IATA regulations, which are recognized by CITES (Convention on International Trade in Endangered Species of wild fauna and flora) and the Council of Europe, are implemented by the member states of the European Union, and other countries such as Canada and the United States. The preface to these regulations states that "In the transport of animals, no aspect is more important than ensuring the safety and welfare of the animals on the ground and in the air".

Many of the professionals in animal transport are also members of the AATA (Animal Transport Association), an international body to which sets high standards for the transport of live animals. Airbus Industrie is a member of the AATA and an industry associate member of IATA.

Animal passengers are not so very different from their human counterparts. They need to feel comfortable when travelling and therefore have specific requirements for warm and fresh air. As with human passengers, the most stressful period is boarding and deboarding, with strange noises, smells and unusual movement. Once on-board the aircraft and conditions have stabilised, most animals will settle-down for the rest of the flight.

Again, as with human passengers, the need for a comfortable environment is important. In general, most animals travel better with cooler temperatures, and adequate ventilation. The combination of high temperature and high humidity is at least uncomfortable for most animals, and in some cases can be fatal. So as to assist the shipper and airline when calculating how many animals can be safely transported under a given set of climatic conditions, Airbus Industrie has worked with several international airlines to develop a simplified calculation method allowing the calculation of heat load and moisture rate.

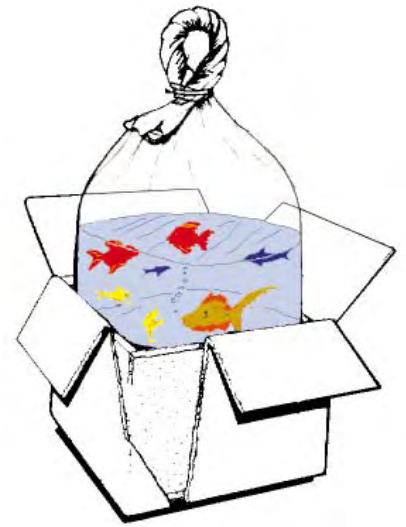

Live Animals label

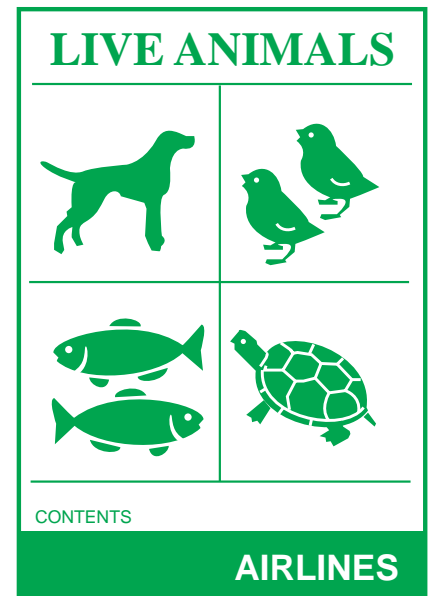

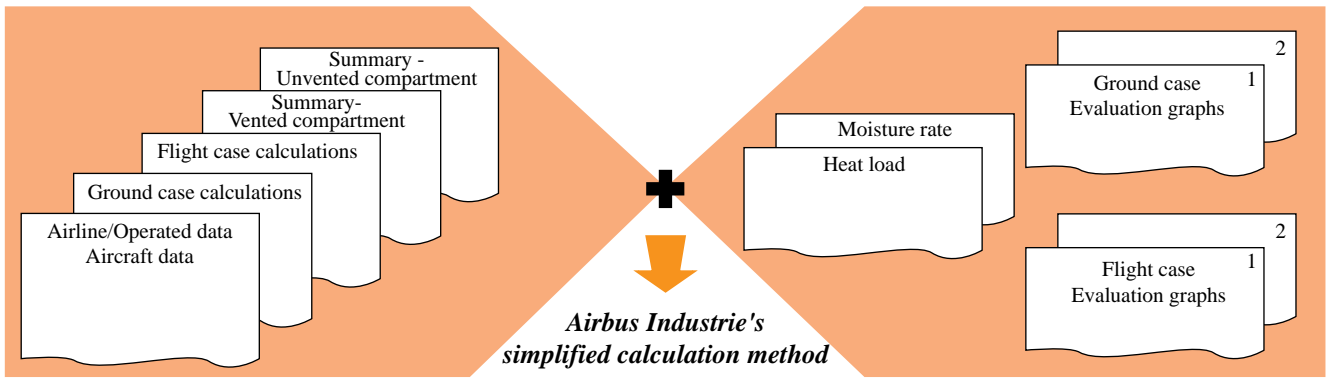

Previous methods required the use of formulae and the reference to a range of graphs, tables and lists.

The simplified calculation method developed by Airbus Industrie is based on a series of graphs and a Basic Data Form (see below). Using this simplified method it is possible to determine whether or not the planned load can be carried safely under the given climatic conditions.

The *heart* of this calculation method is sheet 4 of Basic Data Form which is used to collect the required basic data and the results provided by the various graphs. The only manual calculations required are simple arithmetic, all other calculations are made by the sets of graphs.

The calculation is made in three separate steps:

- **Collection of the basic data**, (temperature and humidity at the departure and destination airports and flight data)
- **Calculation of the heat load and moisture rate of the animals** using a specific set of graphs
- **Evaluation of the resulting relative humidity in the cargo compartment** using a second set of specific graphs

These calculations are made for the ground conditions and for the flight conditions. In each step the result obtained is used as the input to the next step. The final result is a set of three values for cargo compartment relative humidity - at departure airport, at destination airport and in flight, which allows the user to decide if the given conditions are acceptable or not. As was mentioned earlier, the combination of high temperature plus high humidity can be fatal. It is generally accepted that a relative humidity of 80% is the absolute maximum for safe transport of animals.

A presentation brochure is available from Airbus Industrie showing how to use this new calculation method.

For operational use, the Basic Data Form and the related graphs will be incorporated in the Airbus Industrie Livestock Transportation Manual (LTM), together with a worked example and an explanation of the various graphs.

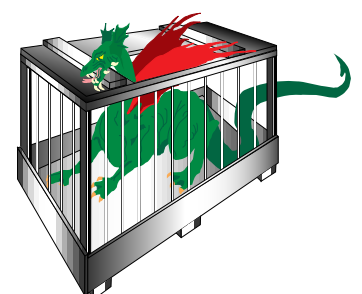

### A310

Livestock Transportation Manual  
**BASIC DATA FORM**

**Ventilated Cargo Compartment only**

Do the evaluation with the respective graphs and compare results with the recommended values from Sheets 2 + 3

FLIGHT PROFILE	Environmental Data	Heat Load Evaluation	Cargo Compt Temp	Total Moisture Rate	Humidity Evaluation
<b>Departure airport</b>	OAT on ground Enter in Graphs 5 + 12 <b>20 °C</b>	Ground Case KW <b>3.3</b> enter in graph 2	<b>25 °C</b> enter in graph 15	<b>2.2</b> g. H <sub>2</sub> O/s use in graph 13	Rel. Humidity <b>71 %</b> Result from graph 15
	Ambient Rel. Humidity Use in Graph 12 <b>60 %</b>	load possible? YES / <del>NO</del>			load possible? YES / <del>NO</del>
<b>Destination airport</b>	OAT on ground Enter in Graphs 5 + 12 <b>16 °C</b>	Ground Case KW <b>3.3</b> enter graph 2	<b>25 °C</b> enter in graph 15	<b>2.2</b> g. H <sub>2</sub> O/s use in graph 13	<b>62 %</b> Result from graph 15
	Ambient Rel. Humidity Use in Graph 12 <b>50 %</b>	load possible? YES / <del>NO</del>			load possible? YES / <del>NO</del>
<b>Flight Conditions</b>	Typical IAS <b>0.8</b> Mach	Flight Case KW <b>4.1</b> enter in graph 2a	<b>20 °C</b> enter in graph 15a	<b>1.9</b> g. H <sub>2</sub> O/s use in graph 13a	<b>55 %</b> Result from graph 15 a
	Typical Altitude <b>35 000</b> ft.	load possible? YES / <del>NO</del>			load possible? YES / <del>NO</del>
	TAT Flight From graph 5a or see below Use in graph 12a <b>- 24 °C</b>				
Graph 5a uses 35 000ft / 0.8 Mach as standard. For other IAS / Altitude use Graphs 5b and 5c to Calculate OAT/ TAT Flight					
<b>Load Possible</b> YES    NO <input checked="" type="checkbox"/> If NO, revise selected temperature or animal load					

Sheet 4/5

Because some of the graphs are cargo compartment specific, it has been necessary to make future editions of the LTM aircraft model specific.

This new method has been incorporated into the A310 Livestock Transportation Manual (LTM) - issue date Jan 95 - and will be progressively incorporated into the Livestock Transportation manuals for the remaining aircraft models.

To assist operators who use computerised documentation, Airbus Industrie has agreed with IATA that this calculation method should be made available in diskette form. The conversion from a paper form into a diskette is being made through the IATA Live Animals and Perishables Board.



### **SOME TOPICAL TIPS**

- ▶ To safely transport live animals the cargo compartment must be provided with the optional ventilation and heating system(s).
- ▶ Do not mix live animals with perishable goods in the same cargo compartment.
- ▶ Do not carry animals that are natural enemies in the same cargo compartment.
- ▶ Refer to the current edition IATA Live Animals Regulations for information on container requirements, labelling, handling procedures, documentation and general requirements.

*When the dogs are happy, the owner is happy too!*

### **LATEST NEWS!**

At the last meeting of IATA Live Animals and Perishable Cargo Board, held in Montreal, Canada, 8 through 10 October 96, a demonstration was given of a prototype diskette for making the live animal calculations. The final version of this diskette version should be available later next year, and will allow such calculations to be made in a matter of seconds.

In addition to making calculations for the number of live animals that can be safely carried, the calculation method developed by Airbus Industrie can also be used to calculate the quantities of perishable cargo which can be carried, and the compatibility of different perishables. ■

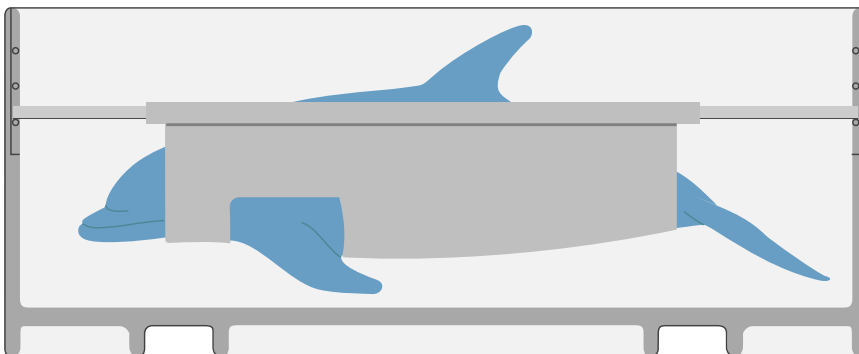

*Copies of the IATA LIVE ANIMALS REGULATIONS can be obtained from:  
IATA, 2000 Peel Street, Montreal, Quebec,  
Canada H3A 2RA  
Phone: 1 (514) 985 6326  
Fax: 1 (514) 844 9089*

*More information about the AATA can be obtained from:  
Animal Transport Association,  
PO Box 60564 AMF,  
Houston TX 77205-0564  
Phone: 1 (713) 443 4595  
Fax: 1 (713) 443-4596 or, in Europe:  
PO Box 251, Redhill, RH1 5FU England  
Phone: +44 1 (737) 82 22 49  
Fax: +44 1 (737) 82 29 54*

*Illustrations on pages 13 and 15 are taken from the IATA LIVE ANIMALS REGULATIONS*



# COMING IN FROM

## IMPROVED WATER AND WASTE SYSTEM PROTECTION

*As operation of the Airbus family of aircraft is progressively expanding, the likelihood of some of them operating in extreme cold weather areas around the world increases. To ensure that Airbus aircraft can operate efficiently in these conditions, cold weather trials were conducted in Canada, Northern Sweden and Siberia.*



# THE COLD



by Luc Leroy  
Cabin Interior & Payload Systems  
Airbus Industrie  
Customer Services Directorate

## FROM FREEZING

What is meant by "Cold Soak" and how does the aircraft manufacturer determine the effects of extreme cold weather conditions? With the introduction of each new aircraft, or new airline operating within these areas the aircraft turnaround times and dispatch reliability must be determined. To evaluate the effects of extreme cold is a complex task and is made even more so due to the fact that the aircraft's passenger and cargo doors must remain open during the turnaround operations!

For those of us that live in temperate climates, it is difficult to imagine how cold the ground temperature conditions can be. We often hear on the TV weather forecast the subject of wind-chill factor and the effect the wind speed has on the air temperature. In certain circumstances the combined effect of freezing conditions coupled with the wind-chill factor can cause the effective temperature to fall below minus 50 °C!

It became apparent to Airbus Industrie that there was a real need to carry out a detailed investigation into the effects of cold weather, and so, with the delivery of an A310 to Wardair in the early 1980s the cold weather programme was launched. This programme was extended to the A320 when Air Canada took delivery of their first aircraft.

As with all aircraft manufacturers, Airbus Industrie quickly realised that the protection from extreme weather conditions would not be an easy task. In fact, to prevent the water and the waste system from freezing requires a balance between the required electrical power, the extra weight generated by the heaters, control systems and the insulation, compared to the extra operations costs to the operators of such a system.

Listed below is the request received by Airbus Industrie from Air Canada for their A320 fleet operating under maximum ambient air temperature minus 40°C and maximum wind speed 50km/h:

- All the cargo doors and one cabin door open for 90 minutes;
- Two additional cabin doors open for 30 minutes;
- Water and waste tanks containing any quantity, up to full;
- APU shut-down;
- Aircraft electrically powered.

Based on the above typical customer criteria, for "cold weather" operators and the experience gained from cold weather campaigns, this article develops the philosophy adopted by Airbus Industrie for the existing aircraft.



**PROTECTION FROM FREEZING FOR THE WATER AND WASTE SYSTEMS**

The following principles are applicable for all Airbus Industrie aircraft types.

The potable water lines and control valves, the waste water (also called grey water) and drain mast, and in some cases the toilet system waste dump lines are protected in the areas of possible freezing by electrical heating and insulation.

Of course, equipment that is affected by extreme weather conditions is, where possible, installed within warm areas of the aircraft. However, due to the physical needs of the water and waste system it is impossible to avoid areas such as the landing gear bays and cargo compartments (Figure 1). It is to be noted that the insulation mats in the cargo bay are not installed on the fuselage skin but bonded to the cargo floor panel to avoid water accumulation in the mats.

A typical heater and insulation installation (Figure 2) shows how the ribbon type heater is installed together with the insulation covers that prevent heat dispersion on the heated pipe-lines. The pipe-lines, whether they are heated or not, are equipped with Teflon clamps to

avoid a “cold-bridge” phenomenon.

The water drain valves, located below the cargo floor panels, on the A330 and the A340 are protected by heated cuffs (Figure 3).

In the electronics compartment, where the potable water supply pipe-lines are shrouded to prevent water spillage, an inner line heater is used to prevent the water from freezing.

Further options include heated water and waste servicing panels and heated fill, overflow and drain nipples.

Irrespective of what type of heaters are installed they are all regulated by an associated sensor coupled to a control unit (see Figure 2). The sensors are installed every seven metres in the coldest areas and regulate the temperature between 6°C and 10°C with the exception of the drain mast where the temperature is maintained between 35°C and 40°C.

The “Cold weather package” installed on the Air Canada Airbus Fleet includes additional features, which enable operations of their aircraft at minus 40°C (see Figure 4 and compare it with Figure 1). These features include the capability to depressurise the potable water system on the ground, thus enabling the non-heated items such as the water filter or the faucet to be drained

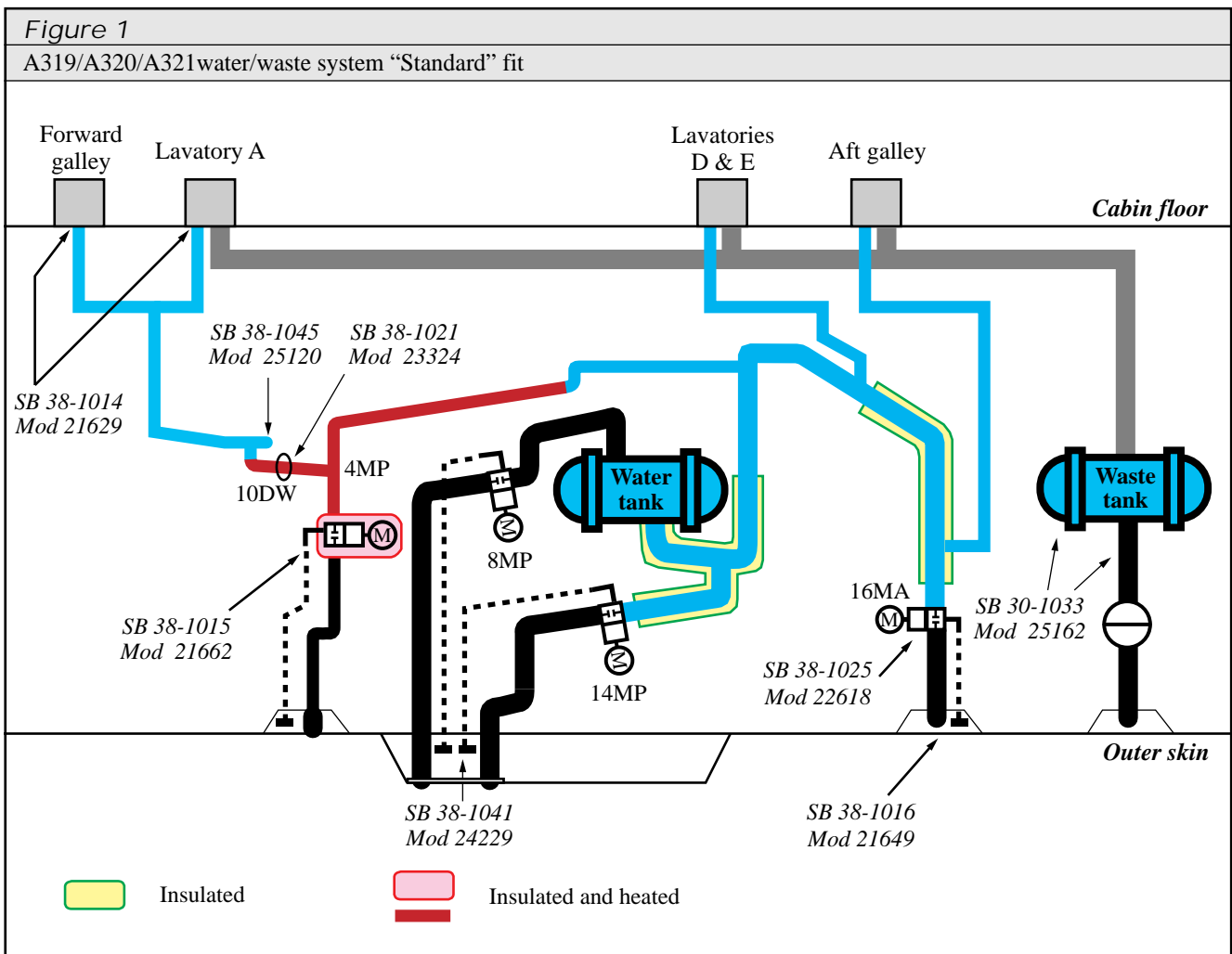

Figure 2

Ribbon heater

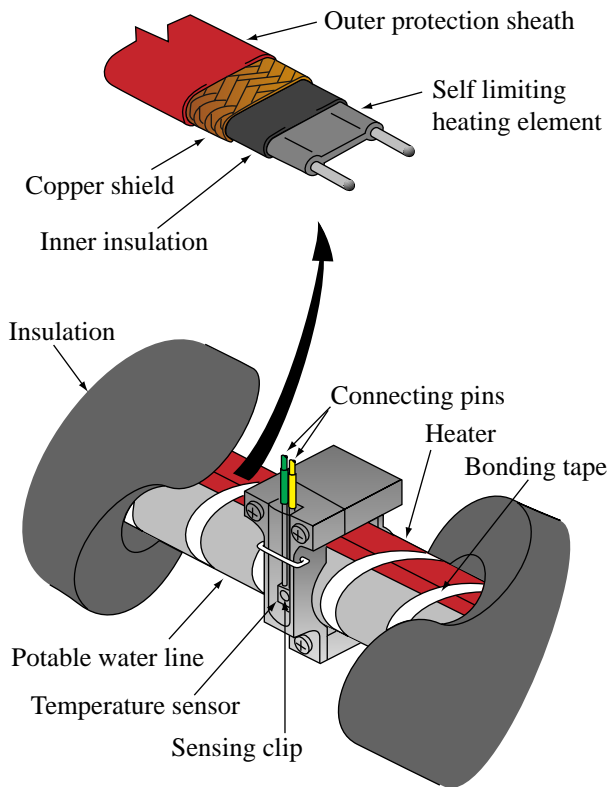

Figure 3

Cuff heater

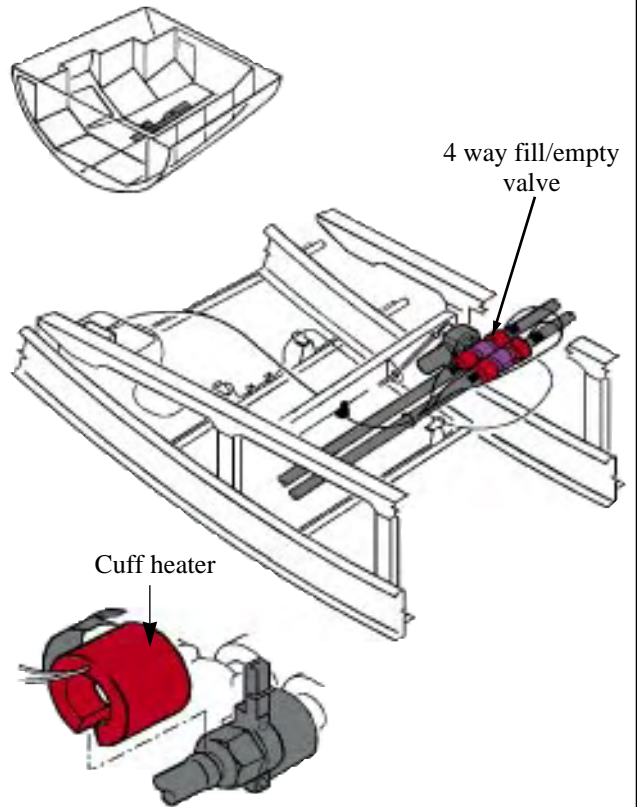

Figure 4

A319/A320/A321 water/waste system "Cold weather package" fit (post-Mod 21597)

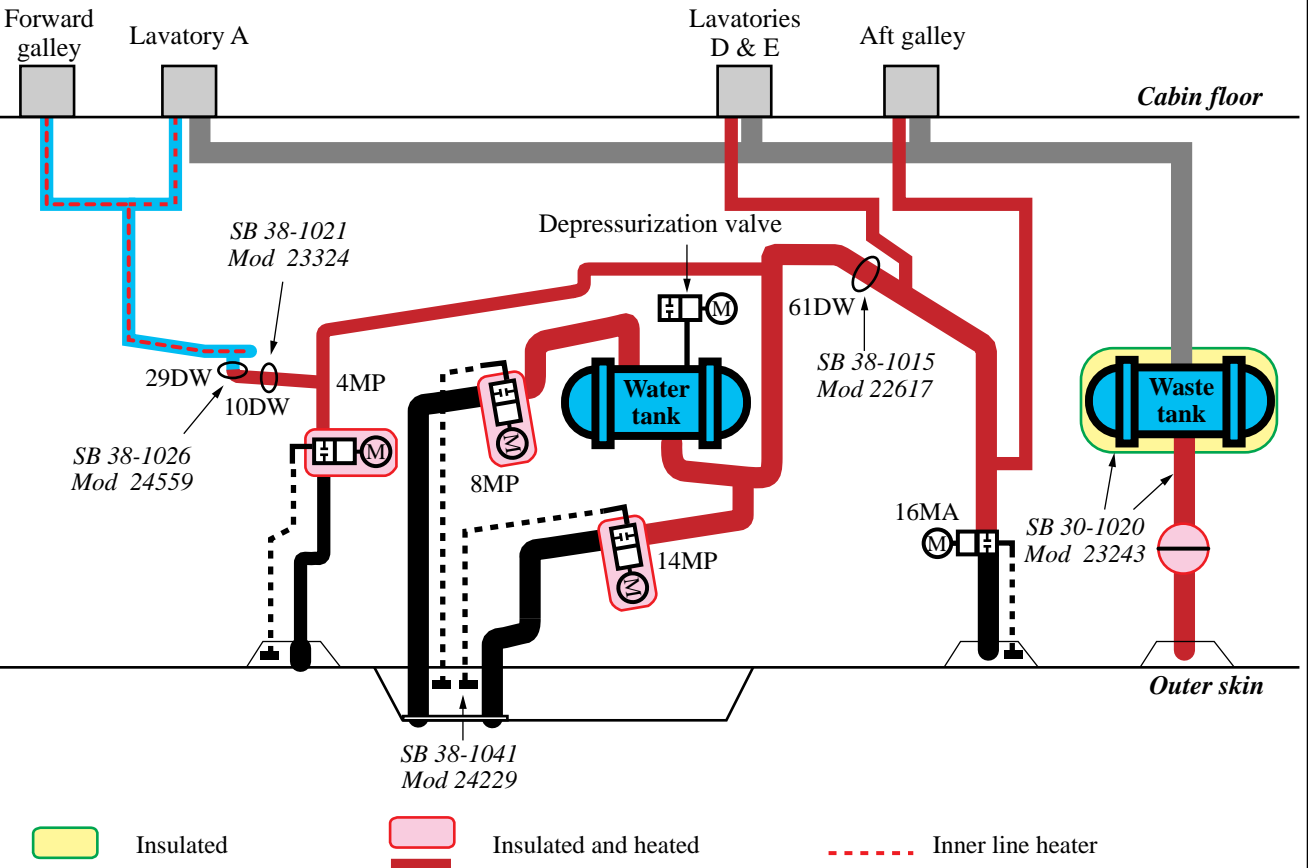
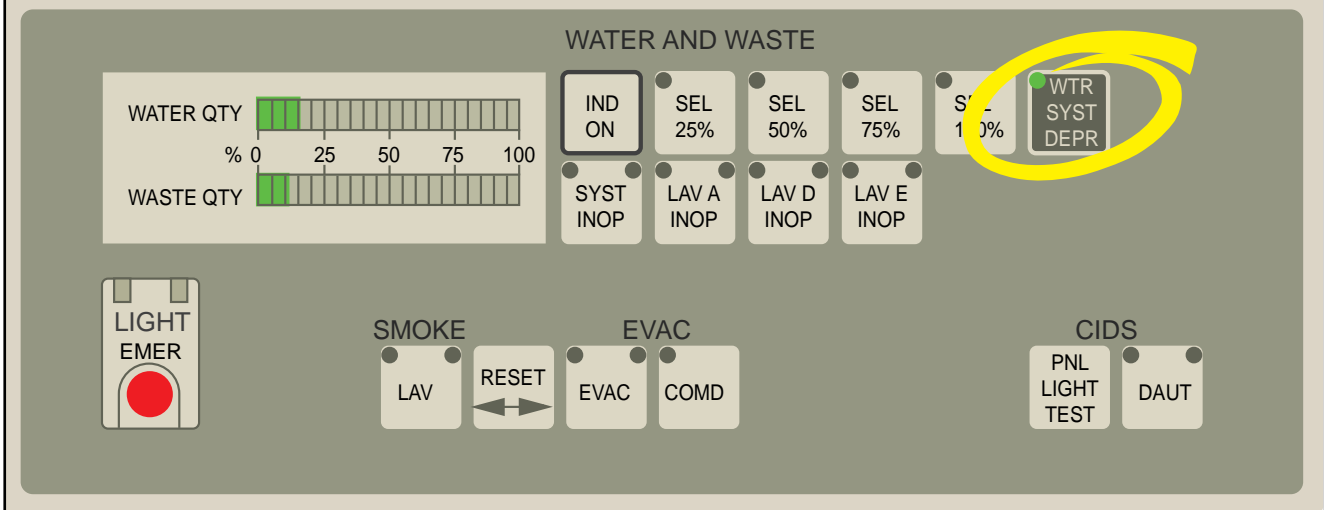

Figure 5

Forward attendant's panel (FAP)



into the heated tubes below the cabin floor and water tanks; additionally, the lavatory water heater, air compressor (if installed) and the vacuum toilets are switched off automatically when the system is depressurised.

The depressurisation of the system is designed to be operated by the mechanics and/or the cabin crew from a switch on the Forward Attendant's Panel (FAP) (Figure 5).

#### KNOWLEDGE FROM WEATHER CAMPAIGNS AND IN-SERVICE EXPERIENCE

To assess the effects of extreme cold weather on the aircraft systems Airbus Industrie has performed several "cold weather campaigns" using A310, A320 and A340 at Frobisher Bay and Yellowknife in Canada, at Kiruna in Sweden and Yakutsk in Siberia. These tests were performed in the real environment which has proven to be the most effective method to observe and monitor the ground servicing procedures and the efficiency of the protection on the water and waste systems.

Each test aircraft is fitted with numerous temperature sensors, located throughout the aircraft and linked to a data log computer. The computer system provides the means to store data related to the temperature conditions in the heated and un-heated systems and the ambient temperature of the cabin and cargo compartments.

However, as we previously stated, the best way to test the aircraft system behaviour is in real conditions, during daily operations at the customer facilities. Such a test was performed with the assistance of Air Canada, with the entry into service of their A320 fleet. This quickly revealed that the existing protection was not providing adequate pro-

tection for the extremes of temperature variation experienced by Air Canada during normal operations.

Several improvements were shown to be necessary and were subsequently adopted and installed by service bulletins on the fleet. Once installed, the additional protection gave the capability for the aircraft to sustain the temperature conditions and thereby improve the reliability and performance range.

The lessons learnt from these early tests on the A320 were taken into account when Air Canada acquired their first A340, and the additional protection packages were introduced before the entry into service. Following the two cold soak trials, these systems were then fine tuned to provide the Air Canada A340s with excellent reliability during their first winter season operations.

#### CURRENT SOLUTIONS

The following recommendations from Airbus Industrie have been developed and proven to be beneficial to operators in extreme cold weather conditions.

Irrespective of whether the various systems have been upgraded or not, Airbus Industrie has developed specific handling procedures for the maintenance staff to prepare the aircraft during extreme cold weather conditions. These procedures are applicable to all Airbus aircraft, and for the water and waste systems these are contained in the Aircraft Maintenance Manual (AMM) ATA 12-31-38 (Figure 6).

#### A319/A320/A321 programme

Generally, the standard-body aircraft operating in Northern Europe are not affected by cold soak conditions during

the average winter, and therefore do not require the cold weather package. Furthermore, these aircraft that have the cargo compartment heating installed rarely suffer delays due to freezing.

Operations can be placed in three categories:

- Aircraft operated the average winter conditions, such as Western Europe / South East Asia.
- Aircraft operated as above, but with a turnaround, or overnight stop in cold areas, such as at Moscow or Chicago.
- Aircraft operated in continuous cold soak conditions.

These variations in operations has led Airbus Industrie to develop and introduce modifications to ensure that normal dispatch reliability can be maintained regardless of the weather conditions (see table 1).

● **For the aircraft operating in average winter conditions but with overnight stops in cold areas**, a small number of cases were still being reported. Of these cases the most common problem was related to either the “interruption of the water supply at the FWD galley” or “waste servicing panel freezing, unable to dump”.

The forward galley water interruption was attributed to either:

- the low usage of the forward galley,

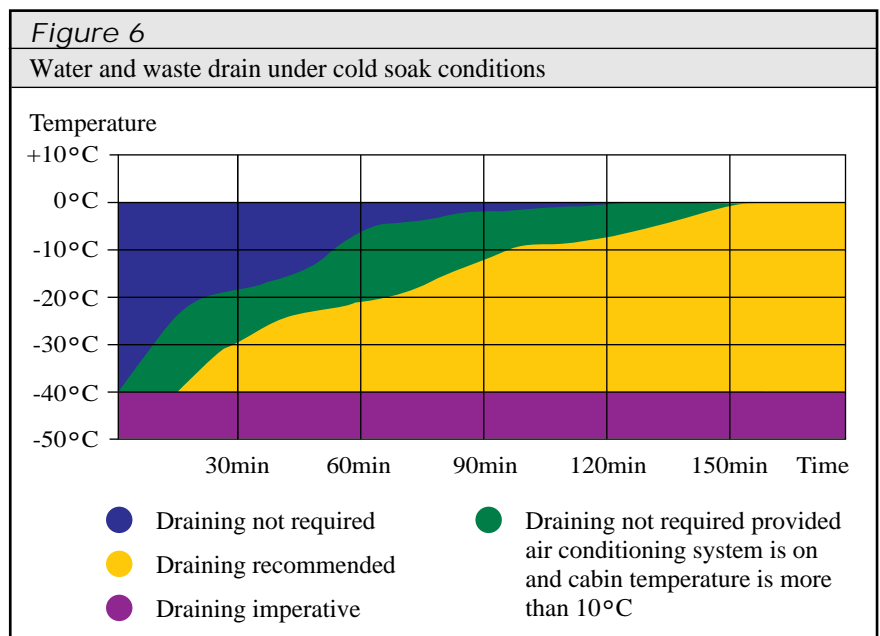

Table 1 A319/A320/A321 Modifications from MSN shown and Service Bulletin availability		
Mod 21 597	SB 38-1029	Install potable and waste water freezing protection
Mod 21629 / MSN 0165	SB38-1014	Install insulation at the forward and aft potable water and water drain lines at the cabin floor interface
Mod 21662 / MSN 0148	SB 38-1015	Relocation of the water drain valve (4MP)
Mod 21649 / MSN 0108	SB 38-1016	Modify the potable water servicing panel
Mod 22073 (in service aircraft only)	SB 38-1020	Install heating element on the fill/overflow drain valve and overflow pipe on the potable water tank installed in aft section
Mod 22617	SB 30-1015	Relocate temperature sensor 61DW for aft waste water lines
Mod 22618 / MSN 0384	SB 38-1025	Improved insulation of the fill/drain valve 16MA
Mod 23243	SB 30-1020	Waste servicing panel freezing protection
Mod 23324 / MSN 0421	SB 30-1021	Forward potable water supply line, relocation of the sensor 10DW
Mod 24229 / MSN 0490	SB 38-1041	Improve mechanism of the overflow valve 8MP and drain valve 14MP control handle (cancels the Inspection SB 38-1023)
Mod 24559	SB 30-1026	Relocate temperature sensor 29DW for forward water supply lines (supersedes the SB 30-1016)
Mod 25120	SB 38-1045	Protect the potable water supply pipe-lines of the Galley 1 from freezing
Mod 25162	SB 30-1033	Freezing protection of the vacuum tank area
Mod 25280 / MSN 0560	SB 30-1030	Improved drain mast (supersedes the SB 30-1007 and SB 30-1017)

related to low passenger load factor during the flight,

○ the forward cargo door being opened, and the combined effect of cold conditions coupled with the wind chill factor, on the ground.

To ensure continuous water supply to the forward galley, Airbus Industrie developed a method to heat the water supply line in the forward section of the aircraft. This improvement was introduced by the modification Mod 25120 and the associated SB 38-1045. As the water lines at this position pass through the electronics bay and are therefore shrouded, these lines required internal heating.

In the aft section of the aircraft, heating the waste servicing panel provided further improvements, particularly during short turnaround times.

The Mod 25162, with its associated SB 30-1033, was introduced further to in-service experience having shown that during servicing:

○ the waste drain valve remained in closed position due to ice formation,  
 ○ the rinse lines were not fully drained at the previous servicing operation, leading to the freezing of the drain nipples.

● **For those operators whose aircraft continually fly from areas of extreme weather conditions**, the complete modification package has proven to be efficient. Refer to optional modifications Mod 21597 / SB 38-1029 which include electrical heating of the complete potable and waste systems below the cabin floor and extend to the waste tank drain valves and servicing panel.

*A300-600/A310 programme*

Dedicated modifications similar to those given previously have also been introduced for the wide-body aircraft (see Table 2). To ensure that these fulfilled the requirements a trial was conducted in 1995, on an A310 in Yakutsk (Republic of Sakha). Temperatures within this region often fall to as low as minus 54°C, and it is reported to be one of the coldest areas in the world.

During this test more than 800 parameters were measured and recorded, in three different types of test conditions. After each test session and overnight cold soak for up to 16 hours a test flight was performed.

From the results gathered, several modifications were developed for the water and waste systems.

*A330/A340 programme*

The long range programme was already subject to the improvements and findings from the A320 tests. As a result, the first A340 to be operated in cold weather areas was already equipped with modification to combat freezing problems (Mod 40959). Additionally, even the pre-production test aircraft was equipped with cold weather protection and monitoring systems.

The modifications on Table 3 have been introduced following in-service experience and analysis of the data gathered from the various cold weather campaigns.

*Table 2*

A300-600/A310 Modifications from MSN shown and Service Bulletin availability

Mod 07210 / MSN 0378	SB 38-2008/6006	Protect water line against freezing (fuselage section 13/14)
Mod 08093 / MSN 0574	SB 38-2012	Relocation of potable water supply line
Mod 08506 / MSN 0638	SB 38-2013/6008	Relocate the aft drain valve (cancels SB 38-2011)
Mod 08643 / MSN 0647	SB 38-2019	Heating of the water servicing panel
Mod 08643 / MSN 0647	SB 30-2020/6015	Water servicing panel heating plate: overheating damage for aircraft having Mod 02517
Mod 08766 and 10923	SB 38-2020	Install freezing protection for the potable water system
Mod 10969	SB 38-2021	Introduction of heated nipples on waste servicing panel
Mod 11033	SB 21-2050	Modify ventilation in toilet Y and Z areas
Mod 11226	SB 38-2022	Relocation of the aft drain valve for aircraft equipped with cold weather package
Mod 11605	SB 30-2024/6018	Introduction of an improved drain mast

<i>Table 3</i>		
A330/A340 Modifications from MSN shown and Service Bulletin availability		
Mod 40959		Install potable and waste water freezing protection
Mod 41657 / MSN0004	SB30-4002	Additional heating in section 16/18
Mod 41999 / MSN0020	SB30-3002/4009	Add heated nipples and heating provisions for valves
Mod 42001 / MSN0020	SB38-3006/4008	Heating of the waste balancing valves and waste drain valve
Mod 42705 / MSN0034	SB38-3033/4038	Inspect the installation of the heater cuff sensors 1310DW and 1320DW on valves 9MA and 22MA
Mod 42730 / MSN0040	SB38-3013/4019	Relocate the potable water heating elements
Mod 42960 / MSN0032	SB30-3009/4015	Replacement of WIPCU
Mod 43025 / MSN0034	SB38-3016/4022	Introduce heating of the waste separating system and overboard vent lines
Mod 44022 / MSN0114	SB30-3014/4019	Introduction of an improved drain mast
Mod 44206 / MSN0114 and 44399 / MSN0114	SB38-3026/4035	Relocate the temperature sensors 330DW and install new support bracket for the fill/drain valve 9MA and cable control

## CONCLUSION

With more than 1500 Airbus Aircraft in service around the world operated by more than 140 customers, work still continues to provide even better solutions. The results from the various cold soak tests coupled with the in-service data are still being evaluated. From this mass of information more is being learnt on air-flow and temperature change, further adding to our ability to design systems that combat problems associated with freezing conditions.

Further research is under way to review the principle of the water and waste system protection from freezing, which in turn may lead to provision of standard aircraft with full cold weather operation capability in a future programme. ■



For any details about these modifications, please contact Mr Alex. SCHNOOR, Retrofit Modification Planning, AI/SE-TR5, Tel.: +33 (5) 61 93 39 13, Fax: +33 (5) 61 93 41 06



# AIRBUS CABIN AIR QUALITY

## *Only the best!*

Measurements of air quality were performed in the past.

However, there was insufficient knowledge about the following contaminants:

- particle countings within fresh and recirculation air and in the cabin,
- types and amount of microbiological contaminations,
- types and amount of volatile organic compounds (VOC).

Thus, Daimler-Benz Aerospace Airbus and Airbus Industrie decided to perform measurements during in-service flights of Airbus aircraft. The study of these three types of contaminants, the measuring principles and the analysis of the results are described in this article.



Dipl.-Ing. Martin Dechow  
Predevelopment Air Systems  
Daimler-Benz Aerospace Airbus GmbH

Two aircraft types were selected to perform the measurements: the Airbus A310 of Swissair and the Airbus A340 of Lufthansa (see Figure 1) for the following reasons :

- The two aircraft types have different air distribution systems installed. While the A310 has got local mixing of fresh and recirculation air with an extraction of the used air from the ceiling area, the A340 is equipped with a central mixing unit. The recirculation air is sucked from the under-floor area forward and aft of the wing.
- The recirculation filters belong to two different generations. The A310 filter development began in 1979. The filter efficiency with particles of 0.51µm in diameter is 90% and 99% with AC coarse test dust. This is much more than for filters which are typically used in building ventilation systems. According to the EUROVENT air filter efficiency classification, this "clean room filter" belongs to the class EU9. The HEPA (high efficiency particulate air) filter of the A340 belongs to the new generation air filter

technology and was developed in 1988/89. This element has a dioctyl phthalate (DOP) efficiency according to MIL-STD-282 of more than 99.97% and belongs to the EUROVENT class EU13. This type of filter is mainly used for medical applications.

- Both aircraft are used for medium and long range operations. Thus, flight time dependant concentrations of contaminants can be evaluated. Some VOC measurements need several hours to detect certain compounds.

Both airlines achieve a high standard of maintenance (e.g. filter removal on time) and accurate cabin cleaning to enable an assessment of the measured air quality parameters.

### PARTICLE COUNTING

#### Measuring principle

Fixed installed equipment was necessary to perform the measurements. It consisted of eight particle sensors, a pressure transducer for flight phase

Figure 1

Selected aircraft types for cabin air measurements: Swissair A310 and Lufthansa A340

■ Central Data Units

Particle Sensors:

- Hatrack
- Dadopanel

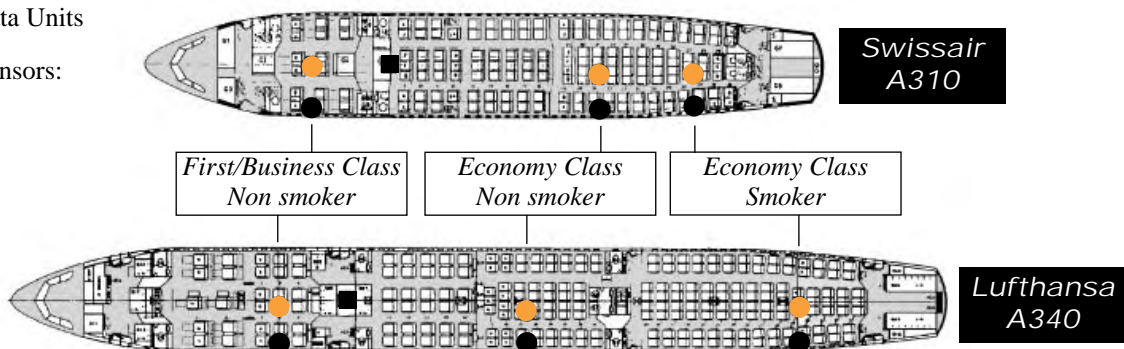

indication and a central unit for power supply and data storage. It was installed within the aircraft for about one year and delivered results during normal in-service flights.

Inside the cabin six particle sensors were installed in pairs in the first (A310) business class (A340), and economy class non smoking and smoking sections. The air intakes of the sensors were located between two centre hatracks (ceiling sensors) (see Figure 2) and close to the floor level behind the dadopanel (floor sensors).

Another sensor was installed in the fresh air duct downstream of the air conditioning pack and one in the recirculating air duct of the cabin air distribution system downstream of the recirculation filter. In the A310 the recirculation air sensor analyses mainly the air of the economy class smoker (zonal recirculation). The recirculating air intake of the A340 was located in the underfloor area and the recirculated air is a mix of the outgoing air of all cabin classes.

The measuring principle of the particle sensors is based on a laser optic that counts the number of particles in the air conducted through the sensor. Particles with more than 0.5µm in diameter were detected.

### Results of the countings

The data were separated according to the following flight phases:

- twenty-five minutes before take off,
- twenty-five minutes after take off,

- cruise condition,
- twenty-five minutes before landing,
- twenty-five minutes after landing.

For ease of analysis the recorded particle counts were averaged and compared as shown in the figures 3a, b and c. From this the following statements can be concluded:

#### ● General Statement

The particle concentration is highly dependant on flight phase and on occupant activity. Thus, peak concentrations are much higher than the cabin mean values and during night flights they are substantially lower.

#### ● Ventilation Air

The mean particle concentration, within the recirculation air is found to be lower than or equal to the fresh air concentration for all ground and flight cases for both aircraft types.

The A310 ventilation system is separated in three cabin zones. Each of the zones has got a local recirculation fan/filter. The worst recirculation air was selected for the measurement (aft cabin zone, mainly economy class smoker). Even this air purified with an EU9 filter is less contaminated than the fresh air before and after take-off and before and after landing (Figure 3a). During cruise the contamination is found to be equal for fresh and recirculation air.

With the HEPA filter used in the A340 aircraft and with a central recirculation system the concentration ratio between fresh and recirculation air is detected to be between 250 during cruise and 2800 before take-off (Figure 3b). The reason for the different

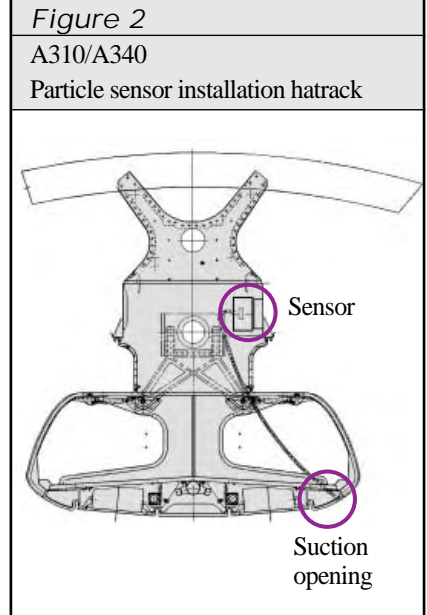

Figure 3a

Particle concentration ratio - between fresh air and recirculated air

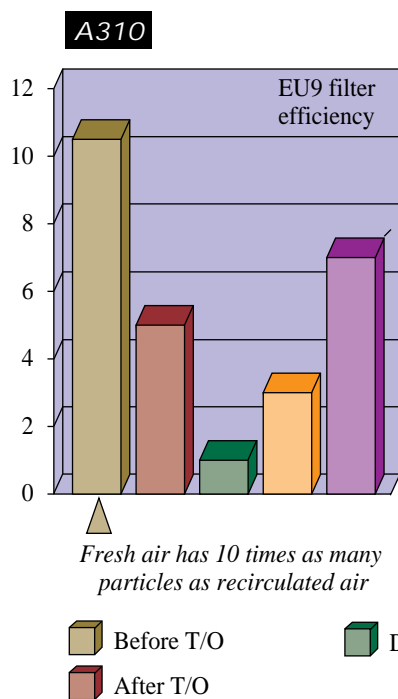

Figure 3b

Particle concentration ratio - between fresh air and recirculated air

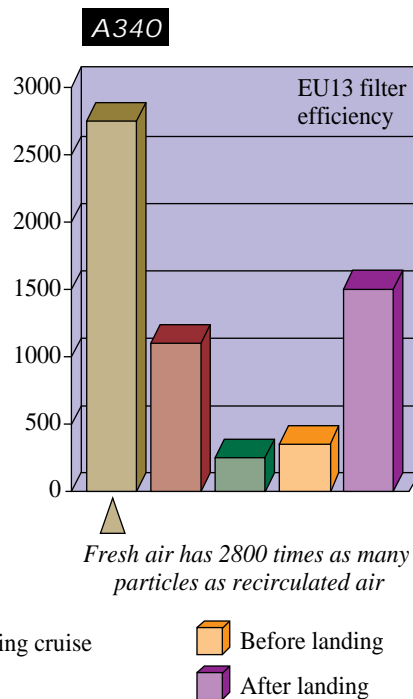
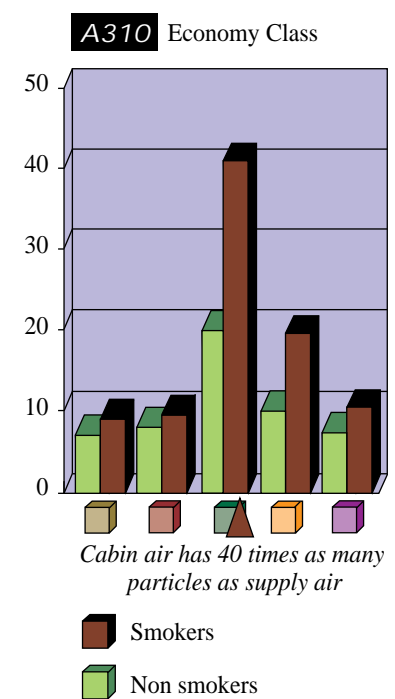

Figure 3c

Particle concentration ratio - between cabin air and supply air



ratio between ground and flight phases is mainly the substantially lower outside particle concentration in higher altitudes. Higher ratios before take-off in comparison to after landing are caused by aircraft queues at the taxi way.

On the ground the fresh air concentration is measured to be between  $10^6$  and  $10^7$  particles per cubic meter. These values are in the lower range of expected outside concentrations in the investigated size range of more than  $0.5\mu\text{m}$  in diameter. Thus, the engine compressor as the fresh air flow source does not emit a high amount of particles to the bleed air system. The concentration during cruise is, as expected, well below that of the ground outside air.

#### ● Differences between cabin zones

Within the A310 cabin the sensors were located at first class (six abreast), economy class non smokers (eight abreast) and economy class smoker. The average concentration of the hatrack and floor sensor was taken as reference for comparison with the supply air.

As expected, the cabin air has substantially higher contamination particles levels than the supply air (mix between fresh and recirculated air) (Figure 3c). Thus, the main emitters are the cabin occupants.

On the ground, when smoking is prohibited, there is just a slightly higher concentration in the smoking section. The initial smoke dust contamination of the smokers clothes could be the reason. During flight, when smoking is permitted, the ratio between the mean concentration smoker/non smokers increases. Peak concentration ratios during heavy smoking phases, e.g. after meals, are significantly higher.

retaining capacity. Smaller germs are detected with a probability of less than 50%, larger ones with more than 50%. A low cut-off value means an accurate measurement device. The equipment used in this study has got a very low cut-off value compared with other devices. Equipment with cut-off values between  $0.65\mu\text{m}$  and  $3.8\mu\text{m}$  are normally used for germ investigations. The usual bacteria size is found to be between  $0.3\mu\text{m}$  to  $3.5\mu\text{m}$ . So the cut-off value has a significant influence on the quality of the test results.

One hundred and eighty one measurements on germ content were performed during this study. The following agar plates were used to detect the germs:

- *Blood agar* - total bacterial germ counts.
- *Blood agar/CO<sub>2</sub>-atmosphere* anaerobic germs or germ growth under reduced oxygen.
- *Xylose-Lysine-Desoxycholate (XLD) agar* - salmonellae.
- *Caseinpeptone-Soyapeptone (CPS) agar* - thermophilic actinomycetes
- *R<sub>2</sub>A agar (deficient culture medium)* detection of environmental germs in a humid milieu.
- *Nutrient agar* - detection of robust germs in air and dust.
- *Sabouraud-(4%-)glucose (SA) agar* moulds (mesophilic and thermotolerant).

The detection of airborne viruses is not feasible with portable equipment.

### Results of the measurements

The main results of the measurements are:

#### ● Differentiation

The majority of the detected bacteria were non-pathogenic gram positive cocci.

Non-pathogenic aerob spore forming bacteria were much less prevalent.

Micrococci and gram negative bacteria could only be detected at extremely low levels.

No case of salmonella was found in the cabin air. Thermophilic actinomycetes (gam positive bacteria, mainly pathogen/allergen) were not detected.

No staphylococcus aureus was found, staphylococcus epidermis was detected in some cases.

Mould spores were measured in extremely low concentrations.

#### ● Ventilation Air

The ventilation air has a very low contamination level due to the high efficiency of the recirculation filters and the contamination free air in high altitudes. The geometric mean value for the supply air of the A310 cabin was found to be 76 Colony Forming Units

Measuring microbiological contamination

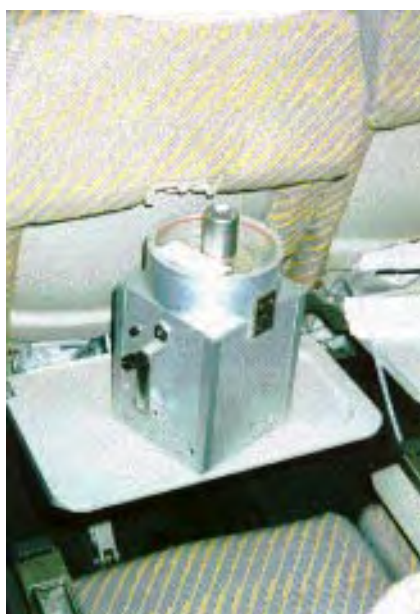

### MICROBIOLOGICAL CONTAMINATION

According to many newspaper articles there is supposed to be substantial health risk when flying due to a high microbiological contamination and the spread of bacteria and other germs through the recirculation system.

#### Measurement Methods

A portable device, different to the particle counters described previously, was used for the measurements of the microbiological contamination. They were performed during A310 and A340 scheduled flights.

A slit impactor FH2 was selected for the measurements. The air flow through the device was 50 litres per minute for two minutes. The cut-off value of the equipment is  $0.65\mu\text{m}$ . This value is an important factor for a comparison of different studies. It describes the diameter at which germs are excluded at 50%

(CFU) per cubic metre and for the A340 cabin 28 CFU/m<sup>3</sup>. For comparison: the recommended germ concentration in the ventilation air in hospitals is <50 CFU/m<sup>3</sup> for operating theatres and <150 CFU/m<sup>3</sup> for dispensation rooms, new-born baby wards and intensive care wards. Thus, the ventilation air of the A340 cabin fulfils the recommended germ concentration for operating theatres, and even that of the A310 cabin with less efficient filters closely approaches the operating theatre level.

*There is no reason for passengers to be apprehensive about an infection risk due to the ventilation system.*

#### ● Different Cabin Zones

The bacteria concentration is higher in the economy class than in business or first class. Thus, the main emitters of bacteria are the occupants.

#### Geometric mean values per flight for bacteria are :

- Cockpit during flight 0-370 CFU/m<sup>3</sup>
  - First class (i.m.) 90-400 CFU/m<sup>3</sup>
  - Business class 76-443 CFU/m<sup>3</sup>
  - Economy class 38-1703 CFU/m<sup>3</sup>
  - Galley 30-1703 CFU/m<sup>3</sup>
  - Lavatory (i.m.) 20-790 CFU/m<sup>3</sup>
  - Outside Geneva airport (cold, dry air, February 1994) 140 CFU/m<sup>3</sup>
  - Outside Abidjan/Ivory Coast (hot air, 100% humidity) >10<sup>4</sup> CFU/m<sup>3</sup>
- (i.m.: individual measurements)

For comparison, the Institute of Hygiene and Environmental Medicine of the University of Lübeck, Germany, analysed the concentrations in other indoor spaces on the basis of a bibliographical investigation. Typical mean bacteria concentrations were found to be between 500 CFU/m<sup>3</sup> and 3,000 CFU/m<sup>3</sup>. Thus, the detected concentrations in aircraft cabin air are in the lower range or below the figures measured in other indoor spaces.

The concentration at the Abidjan, Ivory Coast, airport was detected to be higher (too high for exact detection) than all mean values measured in the cabin.

#### ● Progress of bacteria concentration

Reasons for bacteria peak concentrations are sneeze, cough or even movement of the occupants. An efficient ventilation system has to secure a fast reduction of the bacteria count.

Figure 4

Typical progress of bacteria concentration after a peak

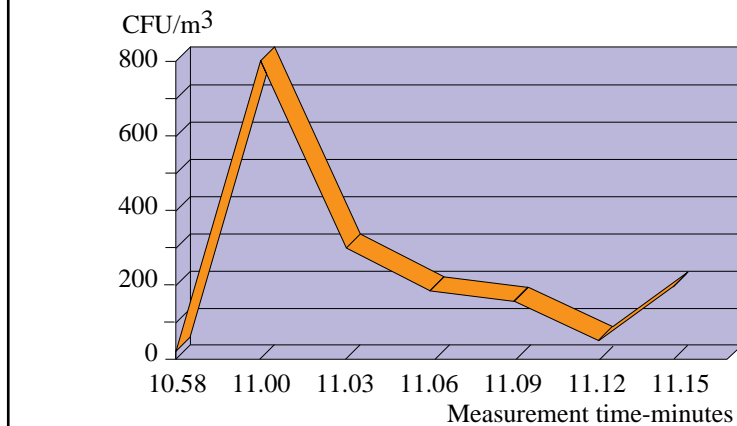

Figure 4 illustrates the good performance of the A340 ventilation system. Seven measurements were performed successively to investigate the progress of the bacteria concentration within a certain period. The second value shows a sudden increase of the concentration. Just three minutes later, with the next measurement, the bacteria level is back in the normal range. This shows the proven effectiveness of the aircraft ventilation system.

#### ● Expert Evidence

The main statements about the results of the microbiological measurements, given by the Institute for Hygiene and Environmental Medicine, Medical University of Lübeck (1), are:

- “Non-pathogenic cocci and spore forming bacteria at maximum levels of 10<sup>3</sup>-10<sup>4</sup> CFU/m<sup>3</sup> are irrelevant to health considerations”.
  - “The only actual health risk is in person to person contact. By sneezing or coughing the infection is transmitted over short distances via droplets.”
  - “Mould spores in these amounts therefore are irrelevant to health considerations.”
- No ventilation system is able to prevent this kind of transmission.

*There is no reason for passengers to be apprehensive about an increased infection risk in aircraft when compared to other highly occupied spaces.*

Thus, the supposed health consideration published in several newspaper articles is found to be without justification for Airbus aircraft.

#### VOC CONCENTRATIONS

While particles - including bacteria and other germs - are removed by the recirculation filters, the gaseous compounds are not filtered within the recirculation loop.



Suction pump and adsorber tubes

### Measurement Methods



The detection of the volatile organic compound (VOC) was performed in parallel to the microbiological measurements. An active measurement with a suction pump and adsorber tubes were used.

The proceeding in measuring VOCs is highly dependant on the expected compounds and their concentration. To detect as many compounds as possible and keep them qualifiable and quantifiable, many different types of measurement tubes and suction flows are necessary. The following tubes are used:

- Activated carbon tubes (NIOSH 100/50mg) with Carbon Disulphide as solvent
- Tenax tubes (NIOSH 30/15mg) with Hexane as solvent.
- Silica gel tubes (NIOSH 140/70mg) with methanol as solvent
- ADT-Tenax tubes (175mg) analysed with thermal desorption
- Impregnated silica gel tubes (EPA-TO-11 300/150mg) with acetonitril as solvent.

When using tubes for solvent extraction the measurement duration must be several hours. Thus, only mean values for concentrations can be found. With an extraction by thermal desorption the required measurement time can be reduced to less than one hour. Then it is possible to evaluate the concentration progress during different flight phases.

The measurements were analysed by the Fraunhofer-Institut for Environmental Chemistry and Ecotoxicology, Schmallenberg, Germany (2).

### Results of the measurements

Sixty-four different compounds were detected, many of them in concentrations too low for quantification. As most of the measurements need a period of several hours, the long-term MAK values (Maximal Arbeitsplatz Konzentration - Maximum workplace concentration) are considered for com-

parison. They are valid for an eight hours a day, five days a week exposure. For nicotine the short-term limit has also to be considered. The concentration peaks were detected with thermal desorbed tubes, which need only 20-40 minutes measurement time. The following main compounds with their amounts, admissible concentrations and origins were found:

- **Ethanol** - The compound with the highest concentration, from 149 to 1780ppb, geometric mean value (GM) 593ppb. Threshold value (MAK) 1,000,000ppb (1,000 ppm).

*Origin: alcoholic beverages.*

- **Acetone** - Measured concentrations 3 to 236ppb, GM value 24ppb. Threshold value (MAK) 500,000ppb.

*Origin: metabolic product, smoking.*

- **Toluene** - Concentrations between 2.3 and 135ppb, GM value 18ppb. Threshold value (MAK) 50,000ppb.

*Origin: mainly fuel ingredient, smoking.*

- **Formaldehyde** - Detected amount 3 to 26ppb, GM value 7ppb. Threshold value (MAK) 500ppb. Indoor limit value of the BGA (Health Agency of Germany) 100ppb.

*Origin: smoking, cleaning agents. No other aldehydes were detected.*

- **Acetic Acid** - Found with 4 to 11ppb, GM value 6ppb. Threshold value (MAK) 10,000ppb.

*Origin: meals, cleaning agents.*

- **Nicotine** - Concentrations between 0.2 and 26ppb, GM value 2ppb. Threshold value (MAK) 70ppb, short-term limit (30 minutes, 4 times during an eight hour period) 140ppb.

*Origin: smoking.*

### Progress during different flight phases

The concentration of particular compounds depends on the flight phase. As the flight dependant concentrations are measured only during one single flight - as thermal desorption of the test tubes is necessary - the figures can just indicate a trend. Two examples are given: nicotine (Figure 5) and the aliphatics (Figure 6).

Nicotine was found in low concentrations during ground periods, when smoking is prohibited. The maximum concentration reached one third of the MAK-value, equivalent to one sixth of the short-term limit. This extreme case happened in the smoker section of the economy class after the meal, when smokers generally are smoking. However, within the non smoking section the nicotine concentration remains at very low levels. This shows a good separation between smoking and non smoking area. Nicotine particles are largely removed by the particle filter.

Figure 5

Concentration progress of nicotine  
(A340 / LH401 on 18 and 19 July 1995)

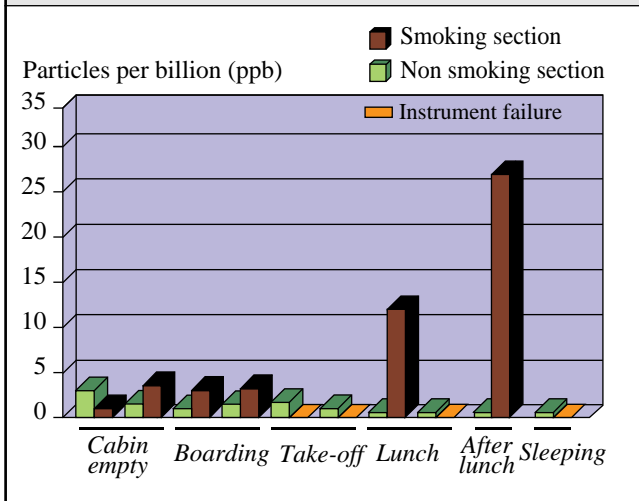
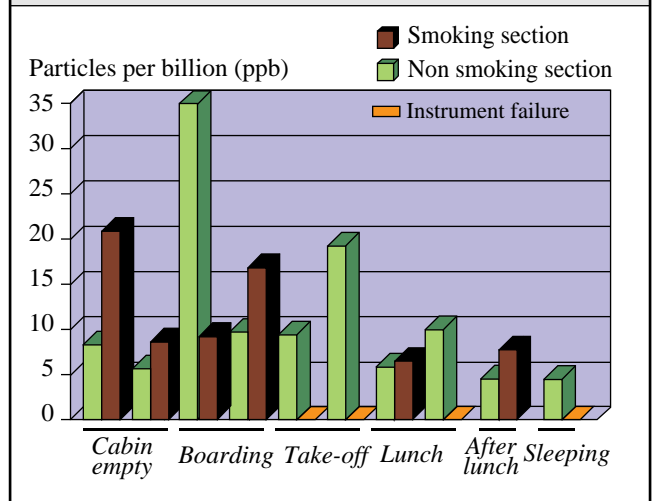

Figure 6

Concentration progress of aliphatics  
(A340 / LH401 on 18 and 19 July 1995)



Aliphatics (n-hexane, n-octane and higher hydrocarbons) are commonly detected as fuel ingredients. Thus, they are found in substantially higher concentrations on the ground than during flight. There was no significant difference between the smoking and non smoking sections.

● **Expert Evidence**

A toxicological evaluation of the results done by Prof. Th. Eikmann (Institute of Hygiene and Environmental Medicine, University of Giessen, Germany) summarised that:

○ “Most of the substances found in cabin air are also present in ‘normal’

indoor air of homes and thus present no unusual exposure situation.”

○ “Wherever the measured values could be compared to existing or proposed indoor guide values, these values were not exceeded in a single case.”

○ “Wherever the MAK-values were used for comparison, these values were not exceeded. This is also true in most of the cases when an appropriate safety factor of 100 is applied.”

○ “A notable exception is nicotine in the air of the smoker section where concentrations approaching MAK-concentrations were determined.”

CONCLUSIONS

All evaluated results show neither relevance to health risks nor - with the exception of nicotine in the smoker section - a comfort restriction. That shows the high level of cabin air quality of Airbus aircraft and the sufficient performance of the air conditioning system to keep the air quality at these levels.

The following main statements can be given as conclusions of this study:

- In case of using HEPA filters the recirculation air is substantially less contaminated with particles than fresh air, even during cruise.
- The particles are emitted by the occupants, mainly by smokers.
- Bacteria types and concentrations do not represent any health risk.
- The bacteria concentration in the supply air is at the level of operating theatre recommendations.
- Mould spores as measured only in very low concentrations are irrelevant to health considerations.
- The only health risk may arise from person to person contact (droplet infection).
- All detected VOCs are found to be in similar concentrations detected in other indoor spaces or lower and do not influence health and - except for nicotine in the smoker section - comfort.
- The concentrations of VOCs depend on the flight phase due to their origin (e.g. kerosene smell on ground, smoking in flight).

We thank Swissair and Lufthansa Technik as well as the Institutes participating for their competent and committed support which were key elements for the successful accomplishment of this study.

References:

- (1) “Methods and Results of the Measurements of Aerogenic Micro-biological Contamination in Airplane Cabin Air” - not published - Opinion of the Institute for Hygiene and Environmental Medicine, Medical University of Lübeck, Germany, December 1995.
- (2) “Report on VOC Measurements during the Flights Frankfurt-Dallas-Frankfurt on 19 / 21.06.1995 and Frankfurt-New York-Frankfurt on 17 / 19.07.1995” - not published - Fraunhofer-Institut für Umweltchemie und Ökotoxikologie, Schmallenberg, Germany, December 1995.
- (3) “Toxicological Evaluation of Cabin Air Concentrations” - not published - Prof. Dr. Med. Th. Eikmann, Institut für Hygiene und Umweltmedizin, Universität Giessen, Germany December 1995.

# RESIDENT CUSTOMER SUPPORT REPRESENTATION

*Mohamed El-Borai, Vice President Customer Support Services Division*

*Telephone: +33 (5) 61 93 35 04 / Telefax: +33 (5) 61 93 41 01*

*Jean-Paul Gayral, Resident Customer Representation Administration Director*

*Telephone: +33 (5) 61 93 38 79 / Telefax: +33 (5) 61 93 49 64*

*Airbus Industrie headquarters*

*1 rond-point Maurice Bellonte, 31707 Blagnac Cedex France*



LOCATION	COUNTRY	TELEPHONE	TELEFAX
ABU DHABI	United Arab Emirates	971 (2) 706 7702	971 (2) 757 097
AMMAN	Jordan	962 (8) 51 284	962 (8) 51 195
ATHENS	Greece	30 (1)981 8581	30 (1) 983 2479
BANGKOK	Thailand	66 (2) 531 0076	66 (2) 531 1940
BOMBAY (MUMBAI)	India	91 (22) 618 3273	91 (22) 611 3691
BRUSSELS	Belgium	32 (2) 723 4824	32 (2) 723 4823
BUCHAREST	Romania	40 (18) 600 250	40 (1) 312 5853
BUENOS AIRES	Argentina	541 480 9408	541 480 9408
CAIRO	Egypt	202 418 3687	202 418 3707
CHENGDU	Peoples Republic of China	86 (28) 521 6511	86 (28) 521 6511
CHICAGO	USA (Illinois)	1 (773) 601 4602	1 (773) 601 2406
COLOMBO	Sri Lanka	94 73 2197 / 2199	94 (1) 253 893
DAKAR	Senegal	221 201 615	221 201 148
DAKHA	Bangladesh	880 (2) 896129	880 (2) 896130
DELHI	India	91 (11) 565 2033	91 (11) 565 2541
DUBAI	United Arab Emirates	971 (4) 822 519	971 (4) 822 273
DUBLIN	Ireland	353 (1) 705 2294	353 (1) 705 3803
DUSSELDORF	Germany	49 (211) 941 8687	49 (211) 941 8035
FRANKFURT	Germany	49 (69) 696 3947	49 (69) 696 4699
GUAYAQUIL	Ecuador	593 (4) 290 005 Ext. 143	593 (4) 293 685
HANOI	Vietnam	84 (4) 88 65 018	84 (4) 88 65018
HO CHI MINH CITY	Vietnam	84 (8) 84 57 602	84 (8) 84 46 419
HONG KONG	Hong Kong	852 2747 8449	852 2352 5957
ISTANBUL	Turkey	90 (212) 574 0907	90 (212) 573 5521
JAKARTA	Indonesia	62 (21) 550 1993	62 (21) 550 1943
JEDDAH	Saudi Arabia	966 (2) 684 2864	966 (2) 685 7712
JOHANNESBURG	South Africa	27 (11) 978 3193	27 (11) 978 3190
KARACHI	Pakistan	92 (21) 457 0604	92 (21) 457 0604
KINGSTON	Jamaica	1 (809) 924 8057	1 (809) 924 8154
KUALA LUMPUR	Malaysia	60 (3) 746 7352	60 (3) 746 2230
KUWAIT	Kuwait	965 474 2193	965 434 2567
LARNACA	Cyprus	357 (4) 643 181	357 (4) 643 185
LISBON	Portugal	351 (1) 840 7032	351 (1) 847 4444
LONDON (LHR)	England	44 (181) 751 5431	44 (181) 751 2844
LOS ANGELES	USA (California)	1 (310) 348 0091	1 (310) 348 8755
LUTON	England	44 (1582) 39 8706	44 (1582) 48 3826
MACAO	Macao	853 898 4023	853 898 4024
MADRID	Spain	34 (1) 329 1447	34 (1) 329 0708
MANCHESTER	England	44 (161) 489 3155	44 (161) 489 3240



<i>LOCATION</i>	<i>COUNTRY</i>	<i>TELEPHONE</i>	<i>TELEFAX</i>
MANILA	Philippines	63 (2) 831 5444	63 (2) 831 0834
MAURITIUS	Mauritius	230 637 3882	230 637 3882
MEMPHIS	USA (Tennessee)	1 (901) 797 6050	1 (901)797 6030
MEXICO CITY	Mexico	52 (5) 784 3874	52 (5) 785 5195
MELBOURNE	Australia	61 (3) 9338 2038	61 (3) 9338 0281
MIAMI	USA (Florida)	1 (305) 871 1441	1 (305) 871 2322
MINNEAPOLIS	USA (Minnesota)	1 (612) 726 0431	1 (612) 726 0414
MONTREAL	Canada	1 (514) 422 6320	1 (514) 422 6310
MOSCOW	Russia	7 (095) 753 8061	7 (095) 753 806
MUSCAT	Oman	968 521 286	968 521 286
NAIROBI	Kenya	254 (2) 822 763	254 (2) 822 763
NEW YORK	USA (New York)	1 (718) 656 0700	1 (718) 656 8635
PARIS (CDG)	France	33 (1) 48 62 08 82 / 87	33 (1) 48 62 08 99
PARIS (ORY)	France	33 (1) 49 78 02 88	33 (1) 49 78 01 85
PHOENIX	USA (Arizona)	1 (602) 693 7445	1 (602) 693 7444
PORT OF SPAIN	Trinidad & Tobago	1 (809) 669 1647	1 (809) 669 1649
PRAGUE	Czech Republic	42 (2) 2011 4193	42 (2) 316 4275
PUSAN	South Korea	82 (51) 971 6977	82 (51) 971 4106
RALEIGH	USA (North Carolina)	1 (919) 840 5016	1 (919) 840 5014
ROME	Italy	39 (6) 6501 0564	39 (6) 652 9077
SAN FRANCISCO	USA (California)	1 (415) 634 4375	1 (415) 634 4378
SAN JOSE	Costa Rica	506 (4) 417 223	506 (4) 412 228
SEOUL	South Korea	82 (2) 665 4417	82 (2) 664 3219
SHANGHAI	Peoples Republic of China	86 (21) 62686671	86 (21) 6268 6671
SHANNON	Ireland	353 (1) 705 2084	353 (1) 705 2085
SHENYANG	Peoples Republic of China	86 (24) 272 5177	86 (24) 272 5177
SINGAPORE	Singapore	65 (5) 455 027	65 (5) 425 380
TAIPEI	Taiwan	886 (3) 383 4410	886 (3) 383 4718
TASHKENT	Uzbekistan	7 (37) 1254 8552	7 (37) 1255 2878
TEHRAN	Iran	98 (21) 603 5647	98 (21) 603 5647
TOKYO (HND)	Japan	81 (3) 5756 5081	81 (3) 5756 5084
		81 (3) 5756 8770	81 (3) 5756 8772
TORONTO	Canada	1 (905) 677 1090	1 (905) 677 1090
TULSA	USA (Oklahoma)	1 (918) 292 3227	1 (918) 292 2581
TUNIS	Tunisia	216 (1) 750 639	216 (1) 750 855
VANCOUVER	Canada	1 (604) 276 3776	1 (604) 276 3548
VIENNA	Austria	43 (1) 7007 3688	43 (1) 7007 3235
WINNIPEG	Canada	1 (204) 985 5908	1 (204) 837 2489
XIAN	Peoples Republic of China	86 (29) 870 255	86 (29) 426 1203
ZURICH	Switzerland	41 (1) 812 7727	41 (1) 810 2383



# Coming in from the cold...

## Part II

**Operating aircraft in extremely cold weather is never easy and it was much more difficult in 1925...**



*Levelling the ice field to prepare a "runway"*

**Roald Amundsen with five companions set out for the North Pole in May 1925 in two Dornier Wal flying boats. These aircraft with their large wing-like floats were judged capable of landing on ice as well as on water. They were powered by two Rolls Royce V-12 Eagle engines mounted back to back.**

**The expedition came to a halt about 250km from the Pole and one aircraft was lost. The crews had to prepare a runway before they could take-off for their return flight. Their problems did not stop there. An aileron jammed forcing them to make a sea landing. Eventually they got back to Norway four weeks after their departure.**



*The explorers moving blocks of ice to fill up crevasses in their "runway"*



*The two Dornier Wals on the glacier about 250km from the North Pole*