

# Space Equipment Power

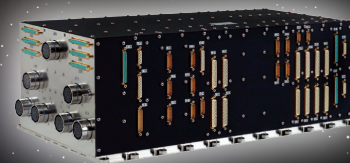

## HIGH POWER PCDU

Dual bus Power Conditioning and Distribution Unit for radar spacecraft application up to 5kW

The High Power PCDU has been originally developed for the X-band Synthetic Aperture Radar Satellite, Terrasar-X. Based on a modular concept that has been already applied by Airbus Defence and Space on several former programs, it is designed to be easily scaled and adapted to different Solar Array power ranges and distribution configurations with a minimum non recurring cost.

For applications in LEO orbit the Power Control and Distribution Unit (PCDU) controls the power flow from the solar generator to the battery and distributes power, on command from the onboard computer, to the instruments, the heaters and the propulsion system. It applies the Maximum Power Point Tracker (MPPT) technology to control

the Solar Array power in order to protect the battery against overcharge. MPPT technology allows to provide, in any condition and whenever it is needed, the maximum power capability of the Solar Array generator. Radar peak power capability is taken directly from the battery to avoid over-sizing the primary power source and the conditioning electronics.

The PCDU is a fully autonomous unit able to work in any sun, eclipse and transition mode without the operation of any other external unit. The PCDU provides a dual bus power system able to distribute up to 5KW of electrical power through unregulated 50V bus and up to 1500W through regulated 28V to bus and instrument units.

### KEY FEATURES

- A single unit to control the power flow from the Solar Generator to the battery and distribute power, on command from the onboard computer, to the instruments, the heaters, the pyro actuators and the propulsion system units
- Solar Array Power is controlled by Maximum Power Point Tracker technology (MPPT)
- Provides a centralised low impedance point for payload and platform power distribution
- Fully autonomous without support from the other satellite subsystems under all operational conditions of the mission including contingency situations
- Single Point Failure Free architecture
- Modular design with more than ten years of heritage including applications on missions such as CHAMP, GRACE, Cryosat, Goce, Lisa Pathfinder and SWARM

### BUDGETS

- Mass: 22.5kg
- Volume: 605 x 300 x 212mm<sup>3</sup>
- Power: 5.5kW @ Unregulated 50V, 1.5kW @ Regulated 28V

### CUSTOMERS / APPLICATION

- Earth Observation Radar Missions: Terrasar-X PCDU, Tandem-x PCDU, Seosar PCDU

### INTERFACES

- Power Bus: Dual Bus (36V to 51V Unregulated & 28V Regulated)
- Solar Array: 2kW, 2 MPPT
- Battery: Li-Ion
- Dialog: HDLC TM/TC Link (ISO/IEC3309)
- Latching Current Limiters:
  - 48 LCL @ 28V
  - 6 LCL of 1200W / each @ 50V
- Heater Outputs: 64 (LCL protected)
- Propulsion Module: 16 Timer Controlled Outputs, for Valves actuation
- Pyro Firing Actuators: 4 Doubled Protected
- Housekeeping Telemetry

### ENVIRONMENTS

- Thermal: -35°C to +70°C
- Radiation: 15krad total dose
- Lifetime: 6 years

### MAIN APPLICATION FIELDS

- Earth observation and Science missions

## Functional description

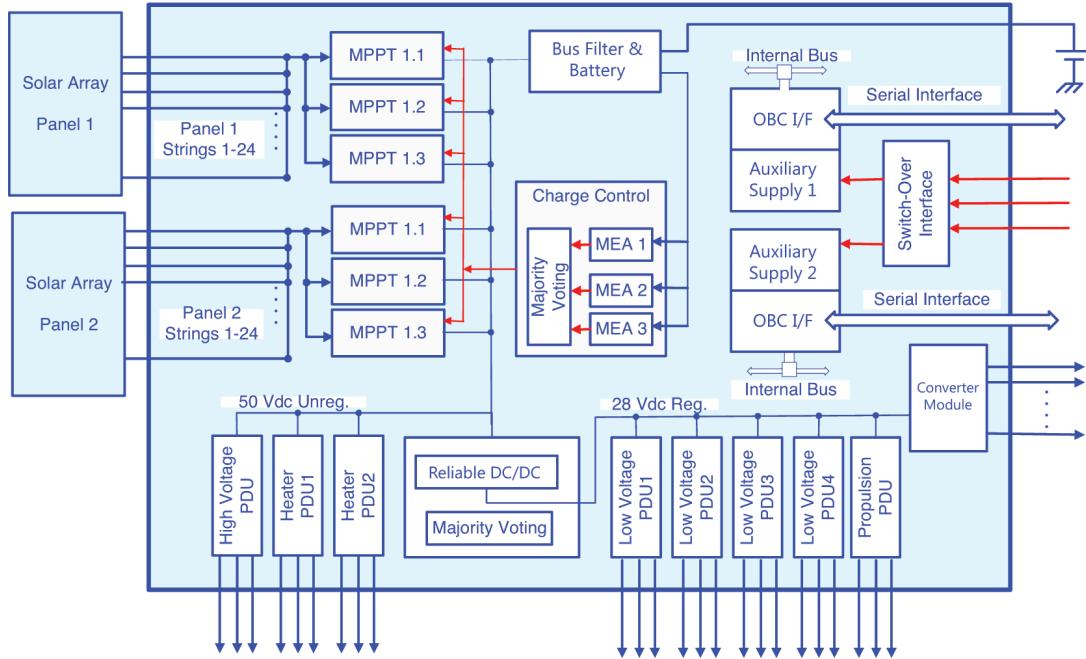

### The PCDU is a fully autonomous Dual Bus Power System consisting of two main parts:

- The Power Conditioning part controls the power flow in the unit from the Solar Array and the battery and performs the communication with the On Board Computer (OBC). The battery charge Control function is tolerant of one failure, by means of three error amplifiers interconnected by a majority voting system. Bus undervoltage protection is provided by Disconnection of Non Essential Load (DNEL), autonomously generated to prevent battery discharge below a preset value.
- The Power Distribution Part provides unregulated 50V and regulated 28V controlled outputs for the platform bus and instruments unit.

### Performances of PCDU

**Solar array power Control:** Six 500W Regulators in MPPT

**Battery Management:** DNEL and Bus Undervoltage Protections

**Solar array power Regulation & 28V Bus Regulator**

- Unique Design, Low Ripple Buck DC/DC
- 500W Max. Power per single Converter
- Efficiency > 95%
- Output Overvoltage Protection 28V LCLs
- 24 switches 0-2.5A
- 8 switches 0-5A
- 16 switches 0-8A

**50V LCLs:** 1.2kW, 38A Trp OFF Limit

**50V Heaters LCL protected**

- 36 switches 1A
- 16 switches 2A
- 12 switches 5A

**Solar array power Control:** Self Healing foil capacitors

### Housekeeping Signals Provided

- Battery Voltage
- Battery Charge/Discharge Current
- Propulsion Tank Pressure
- Solar Array Panel Input Current
- LCL Output Current
- LCL On/Off Status
- Heater Current
- Heater Switch Status
- Power Converter Input Current
- DNEL Command Status Unregulated Bus
- DNEL Status Unregulated Bus
- DNEL Command Status Regulated Bus
- DNEL Status Regulated Bus