

Microfluidics and Biosensors for Point-of-Care Diagnostics

Xuanhong Cheng

Materials Science and Engineering
Bioengineering
Lehigh University

November 24, 2014

Microfluidics for Medicine

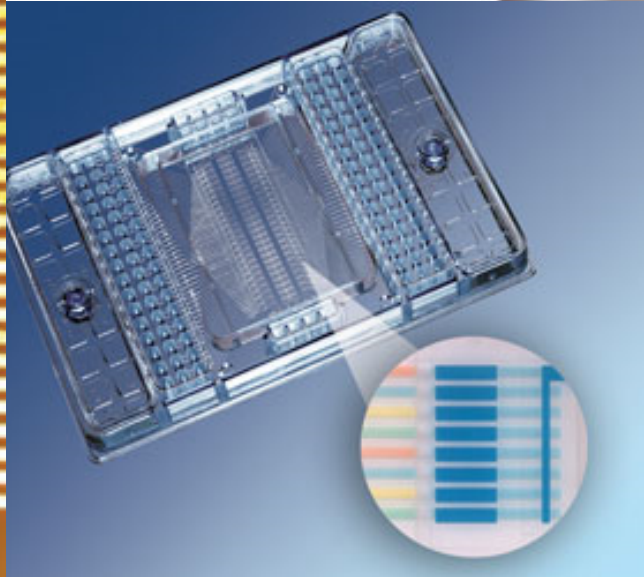
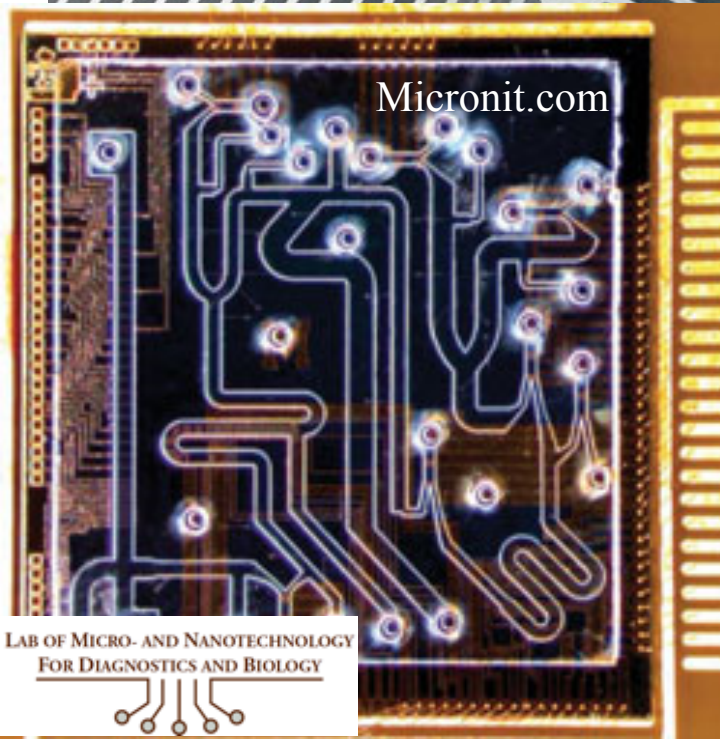

Advantage of Microfluidic Systems

- Small sample volume
- Small reagent volume
- Low production cost
- Portable, potential for integration and automation
- High surface to volume ratio
- Laminar flow, predictable transport property

POC Diagnostics





Micro-scale Fabrication

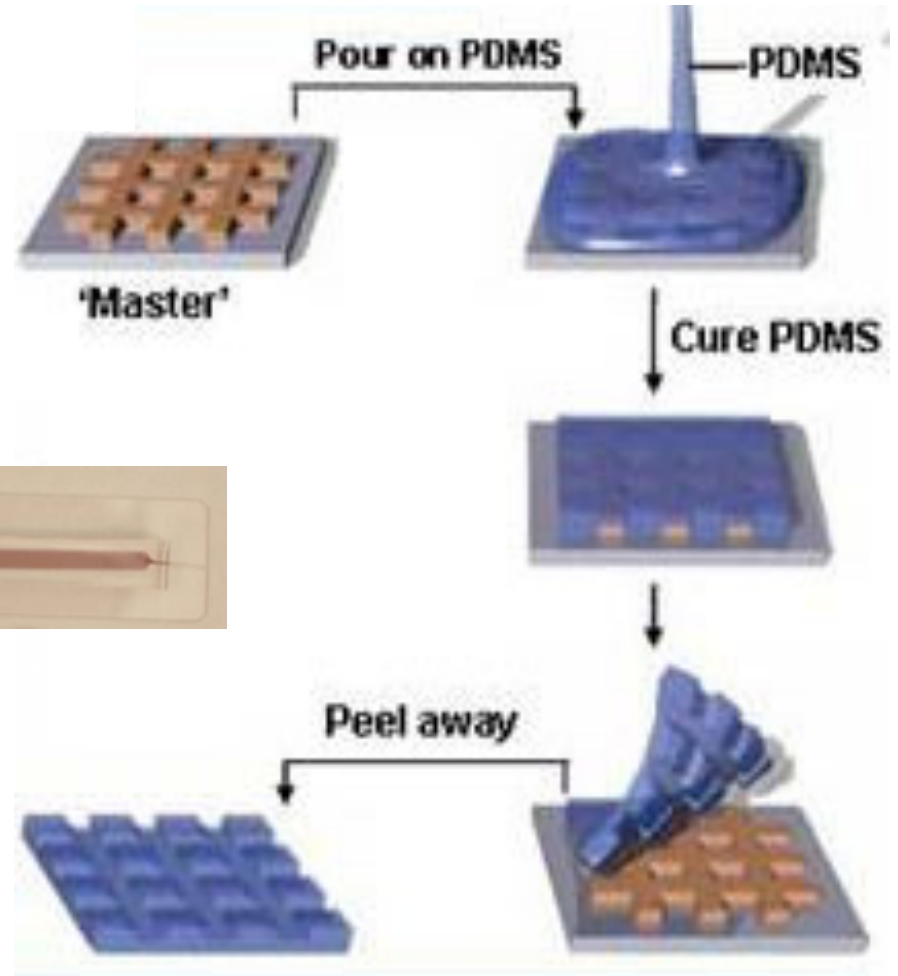
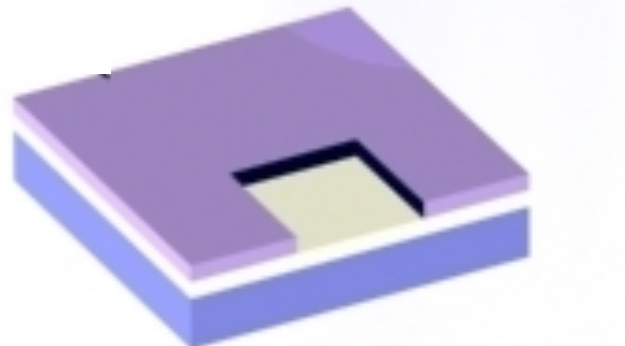
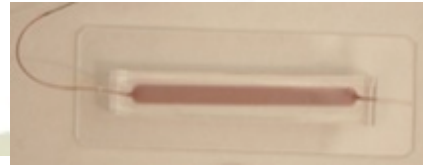
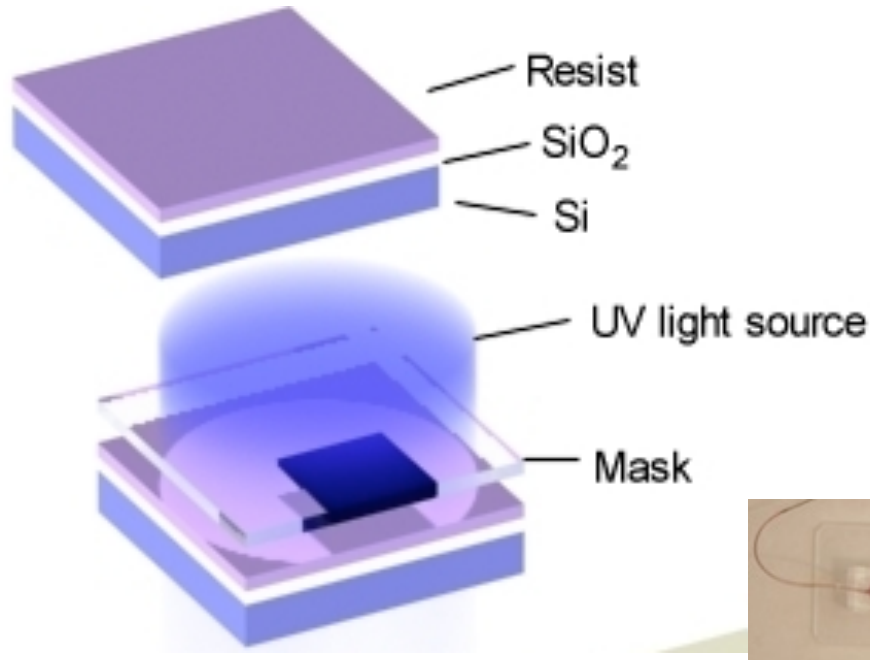

HIV Diagnostics

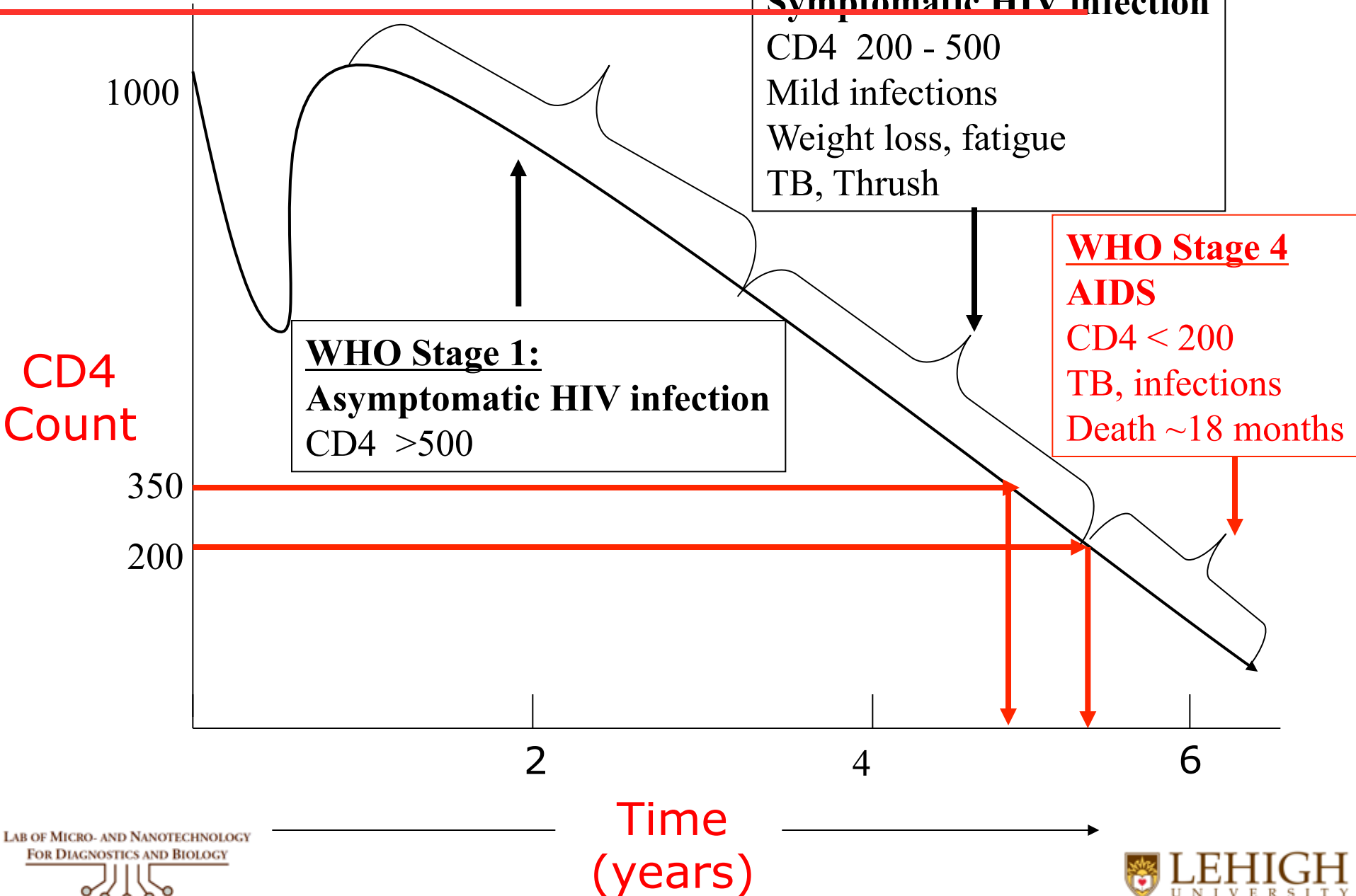

Impact of Treatment

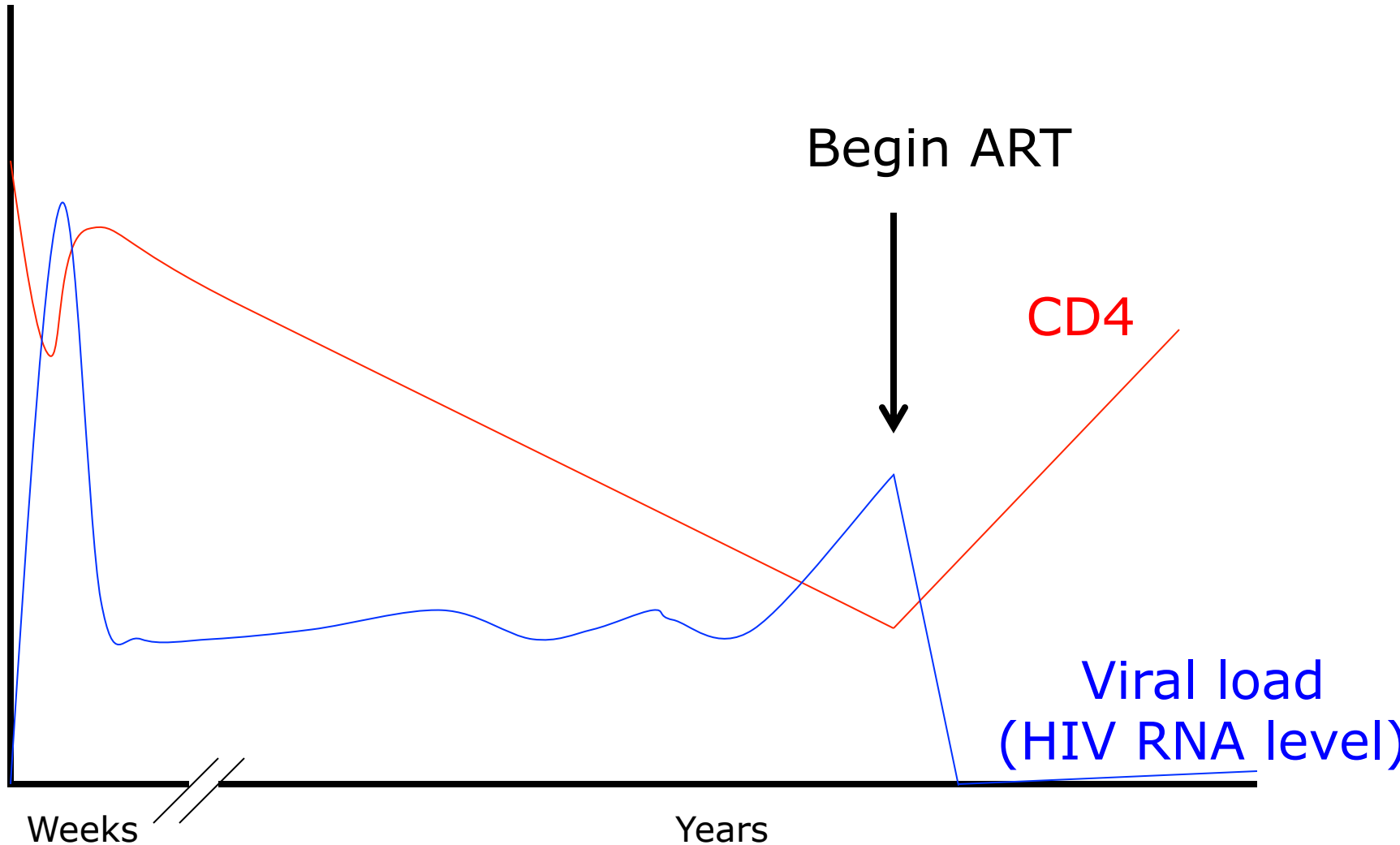

Clinical Indicators

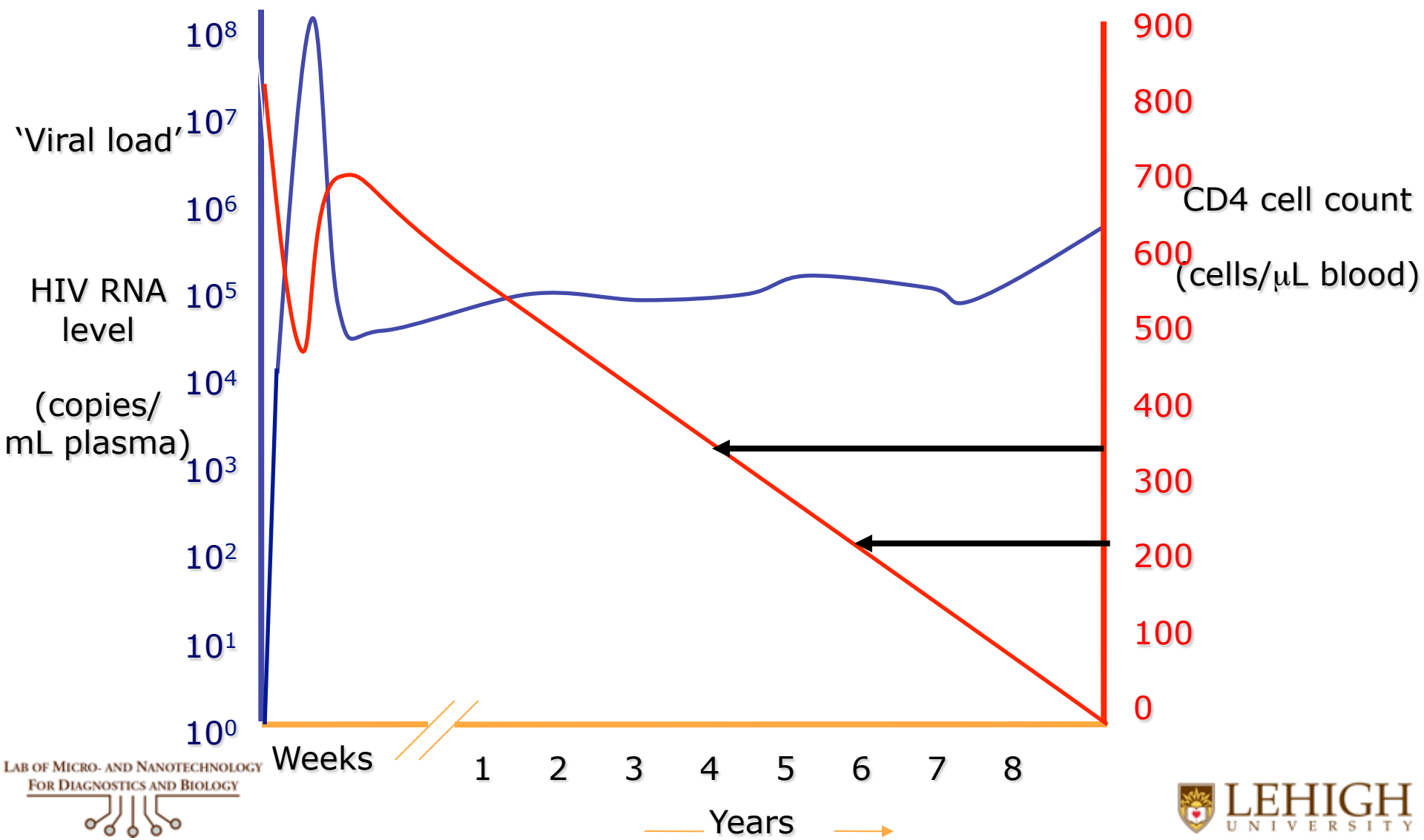

State of the Art Technologies

CD4-count

start treatment < 200 cells/ul



Viral load count

measure resistance to treatment

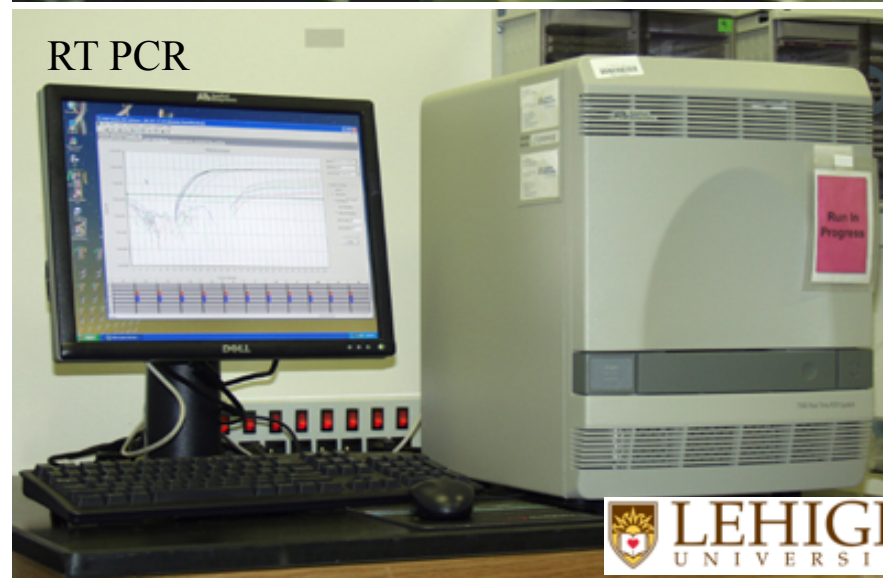

Lab Diagnostics in Resource Poor Settings



What is Needed

- Low cost
- Easy to use
- Rapid and Robust
- Portable
- Sensitive and specific

Microchip Technology for Medicine

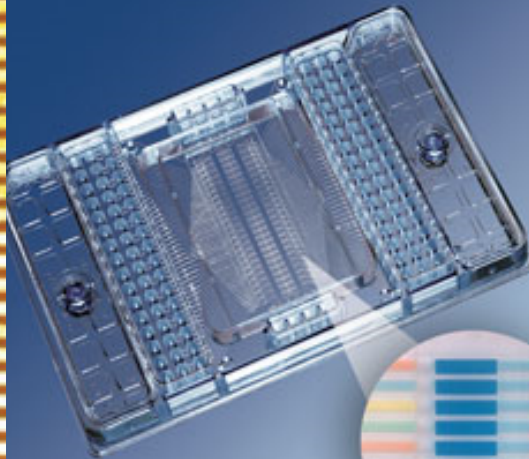
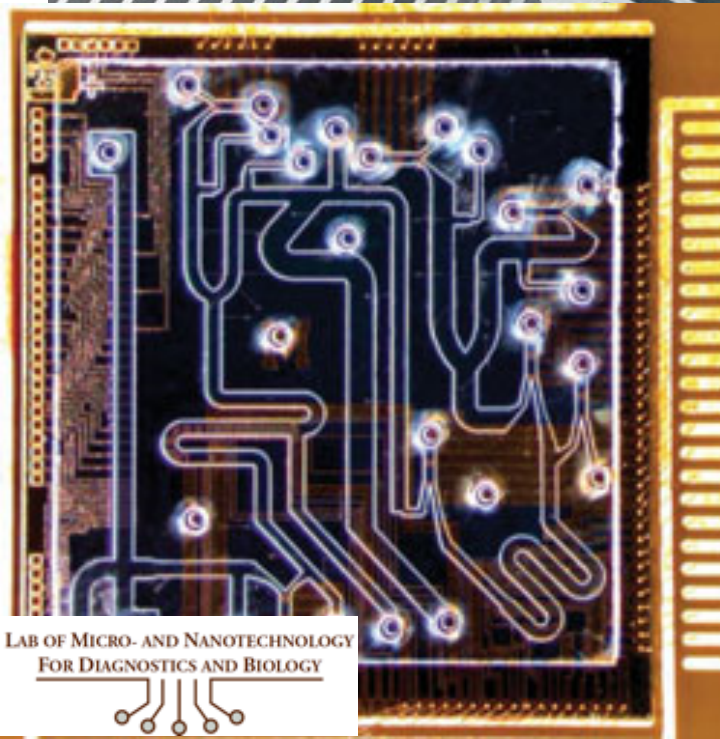

Portable CD4 Counter

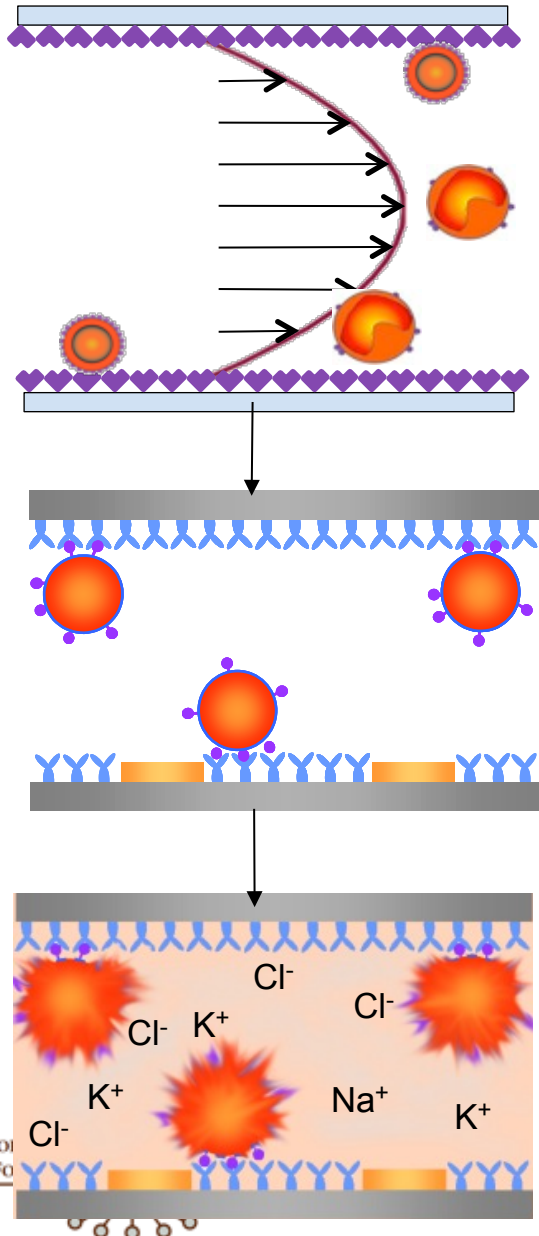

CD4 counting microchip

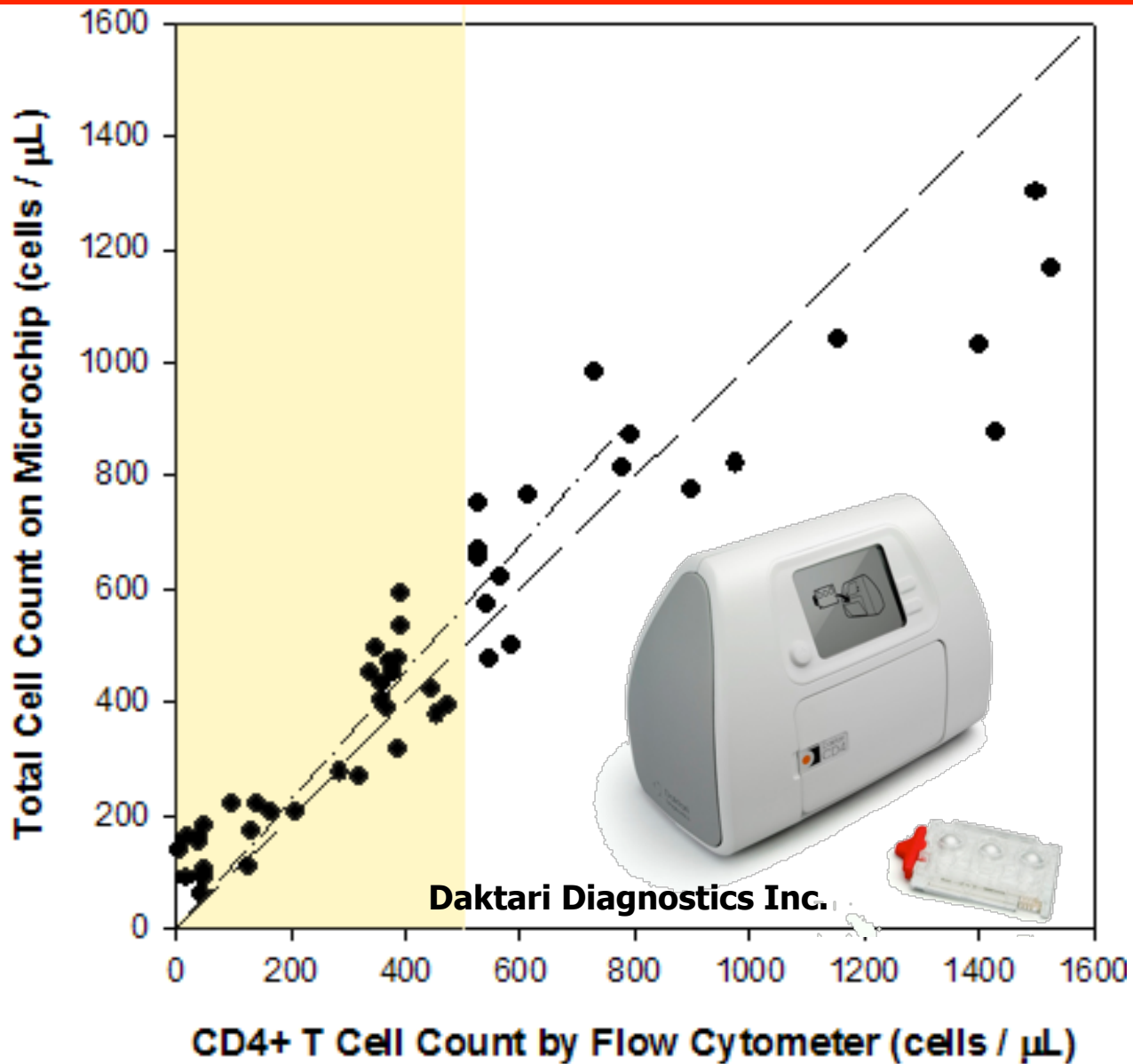

Nanoporous Membrane for Viral Processing and Sensing

- Controllable pore size
- High porosity
- Bio-functionality
- Tight pore size distribution
- Thin membranes

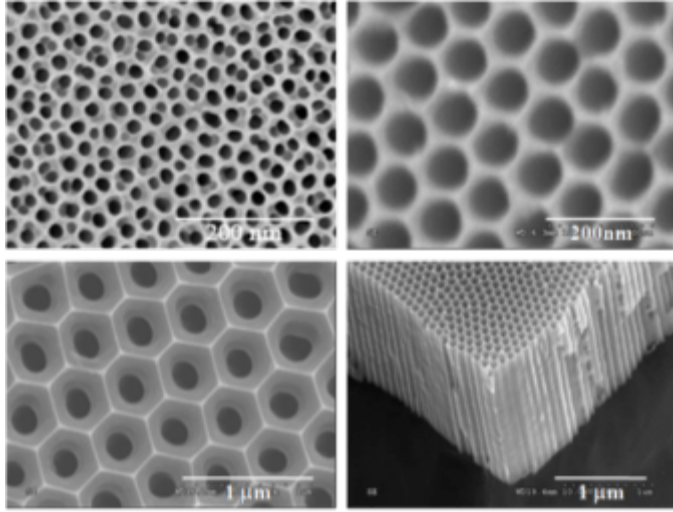
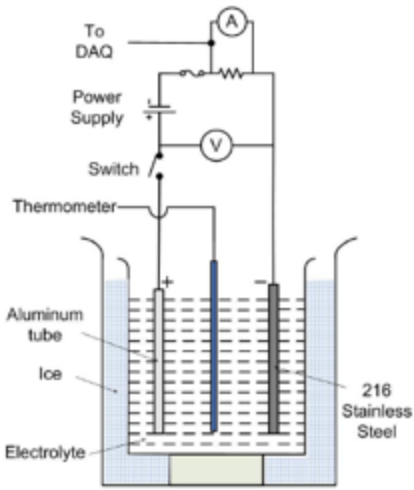
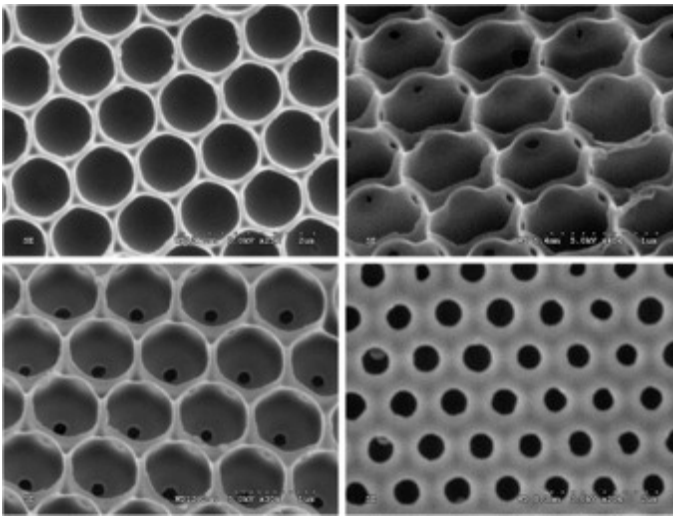
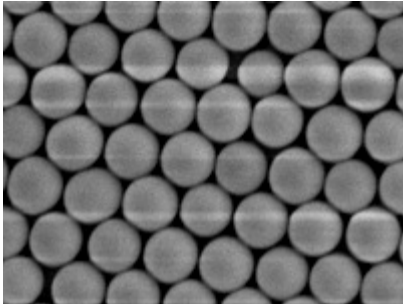

Embedded Nanoporous Membranes for Virus Capture

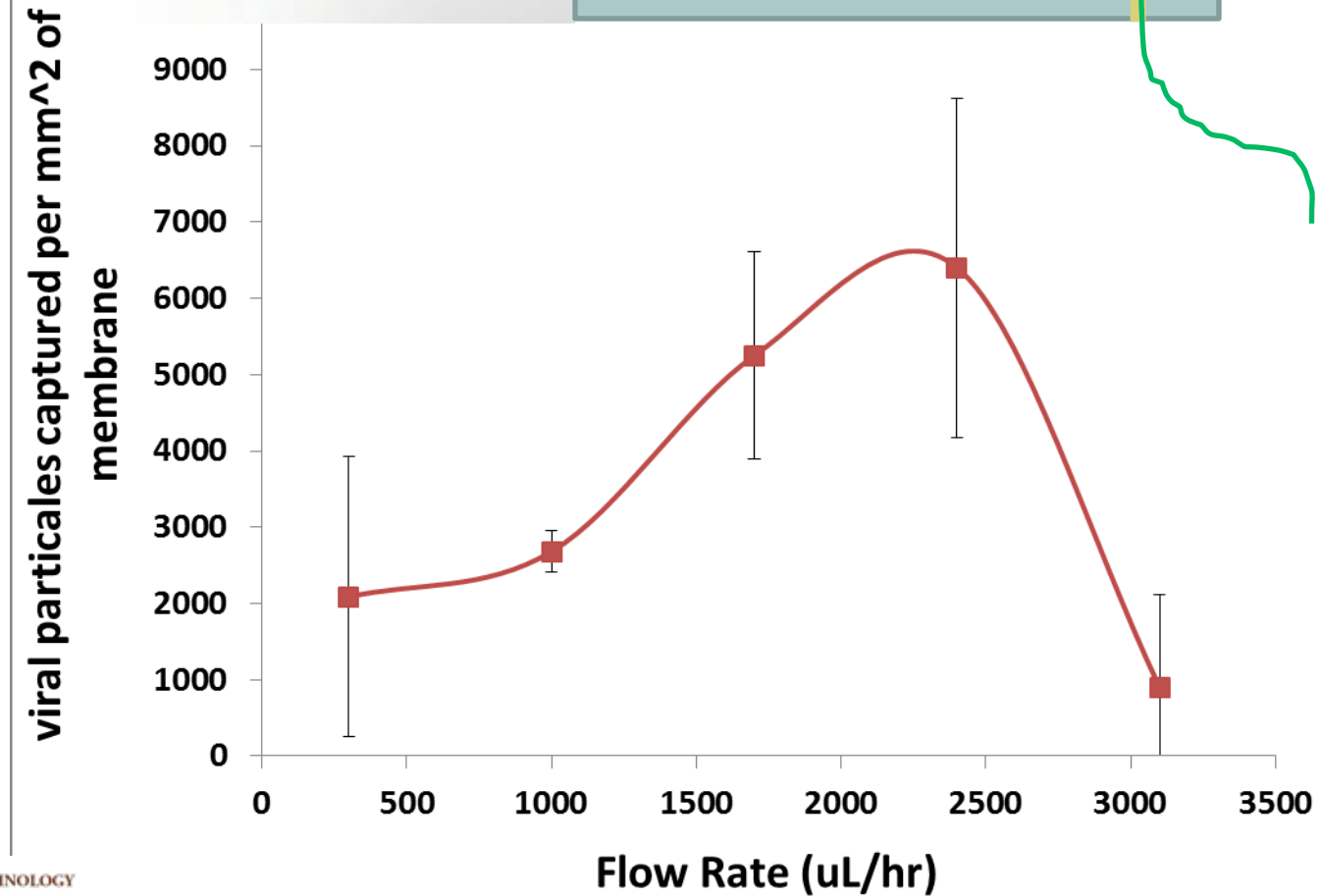
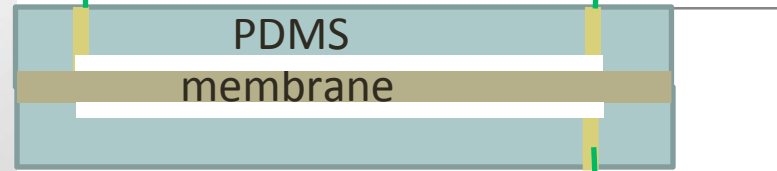

Embedded Nanoporous Membranes for Virus Staining

Inject buffer into the top channel

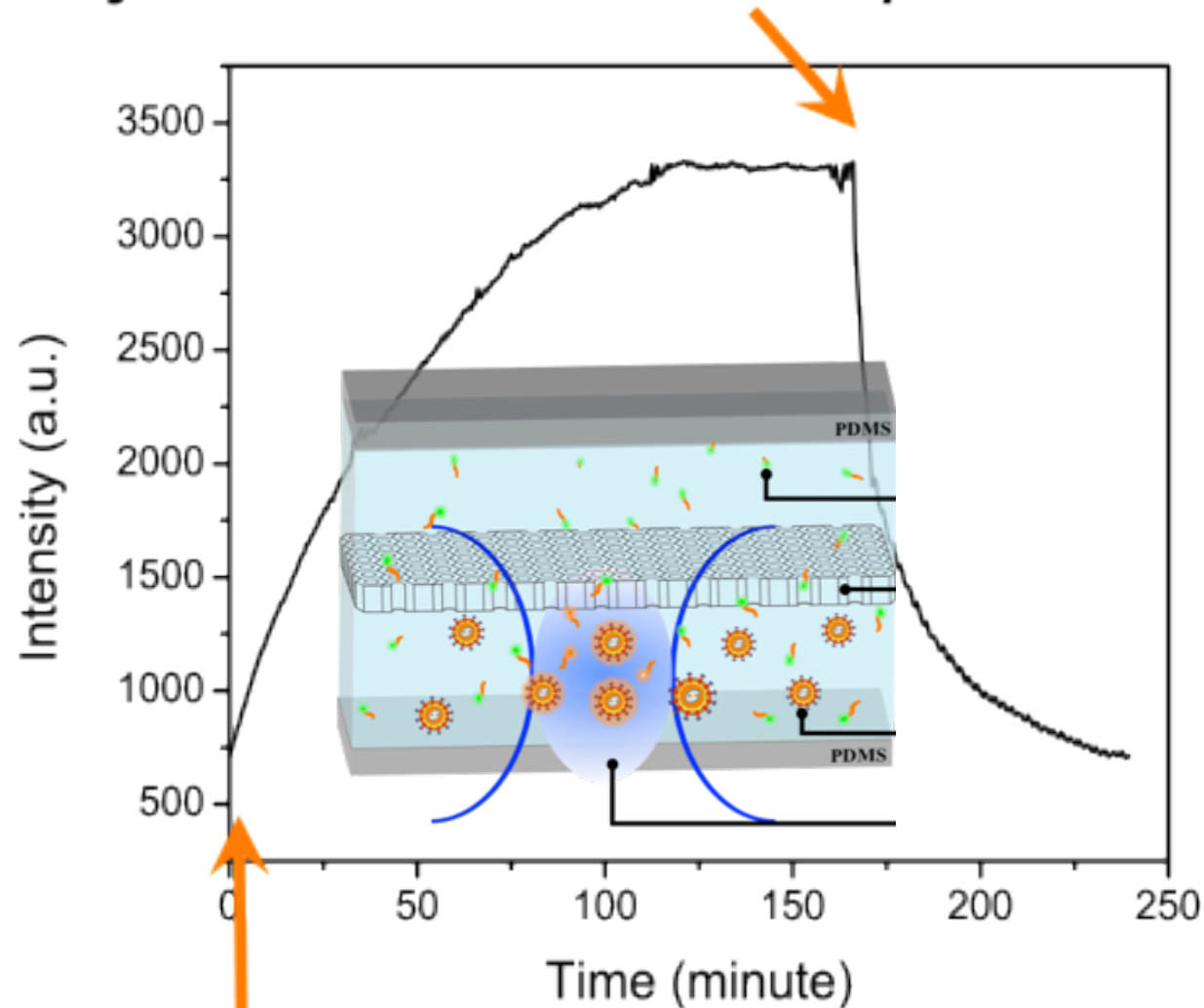

Inject dye into the top channel

Optically Forced Cytometry for Nanoparticle Counting

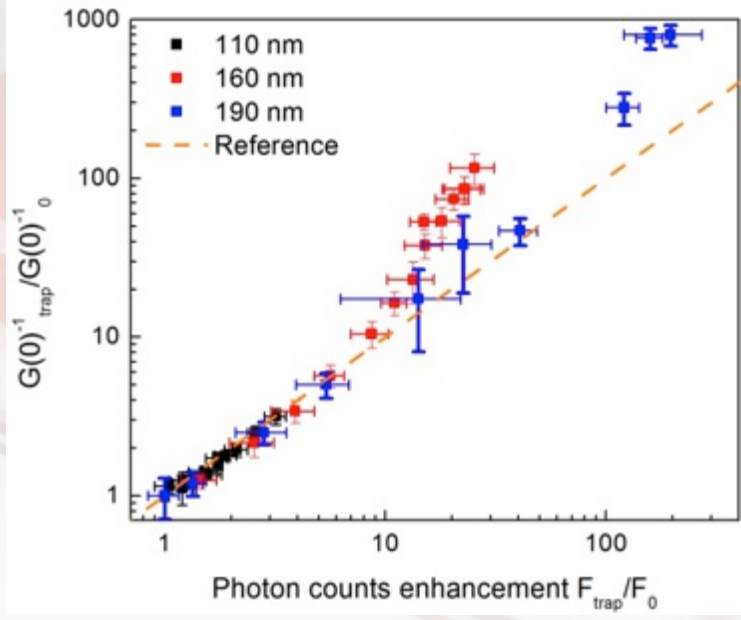
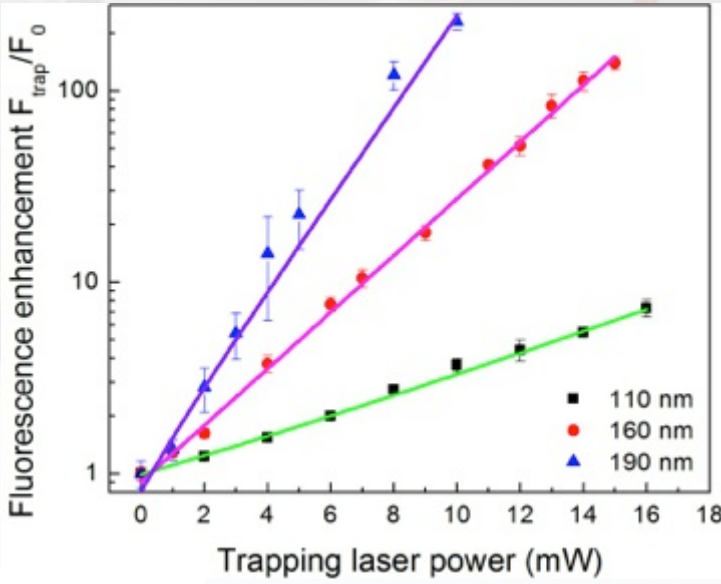
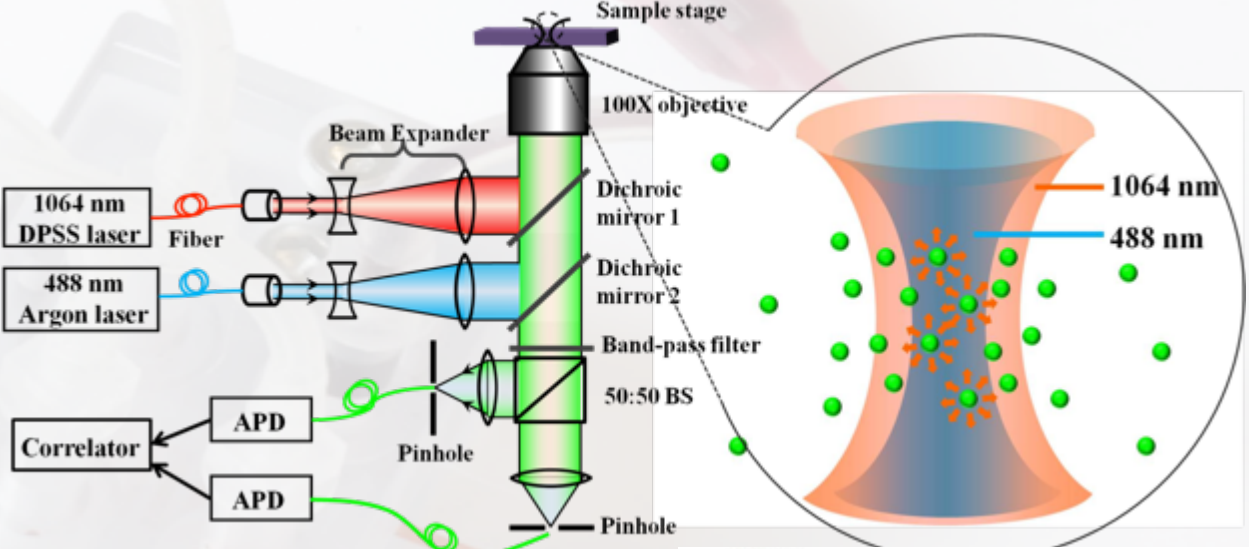

Detection of Bacteria Viability

Cell Staining

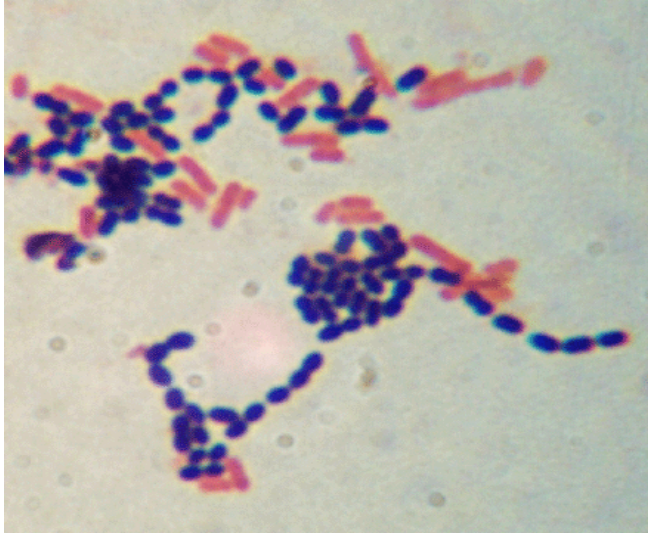

Flow Cytometer

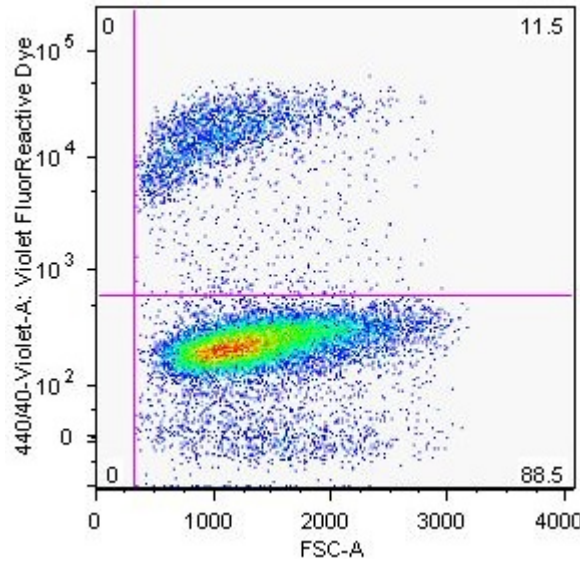

Molecular Markers

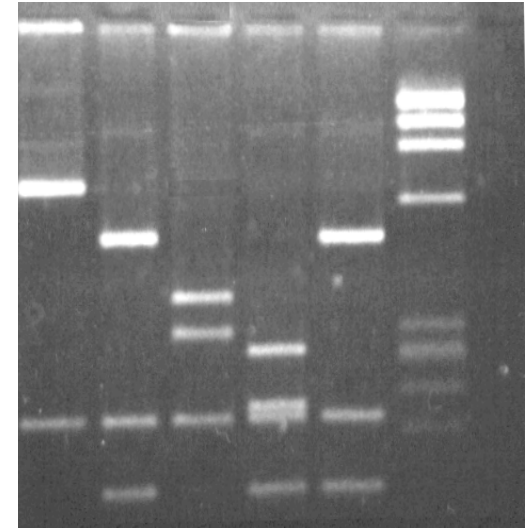

- Significant in clinical diagnosis, biohazard surveillance, food safety monitoring, etc.
- Contemporary approaches require laboratory access
- Electrical test can be fast, compact, sensitive and label free

Broadband Electrical Sensing

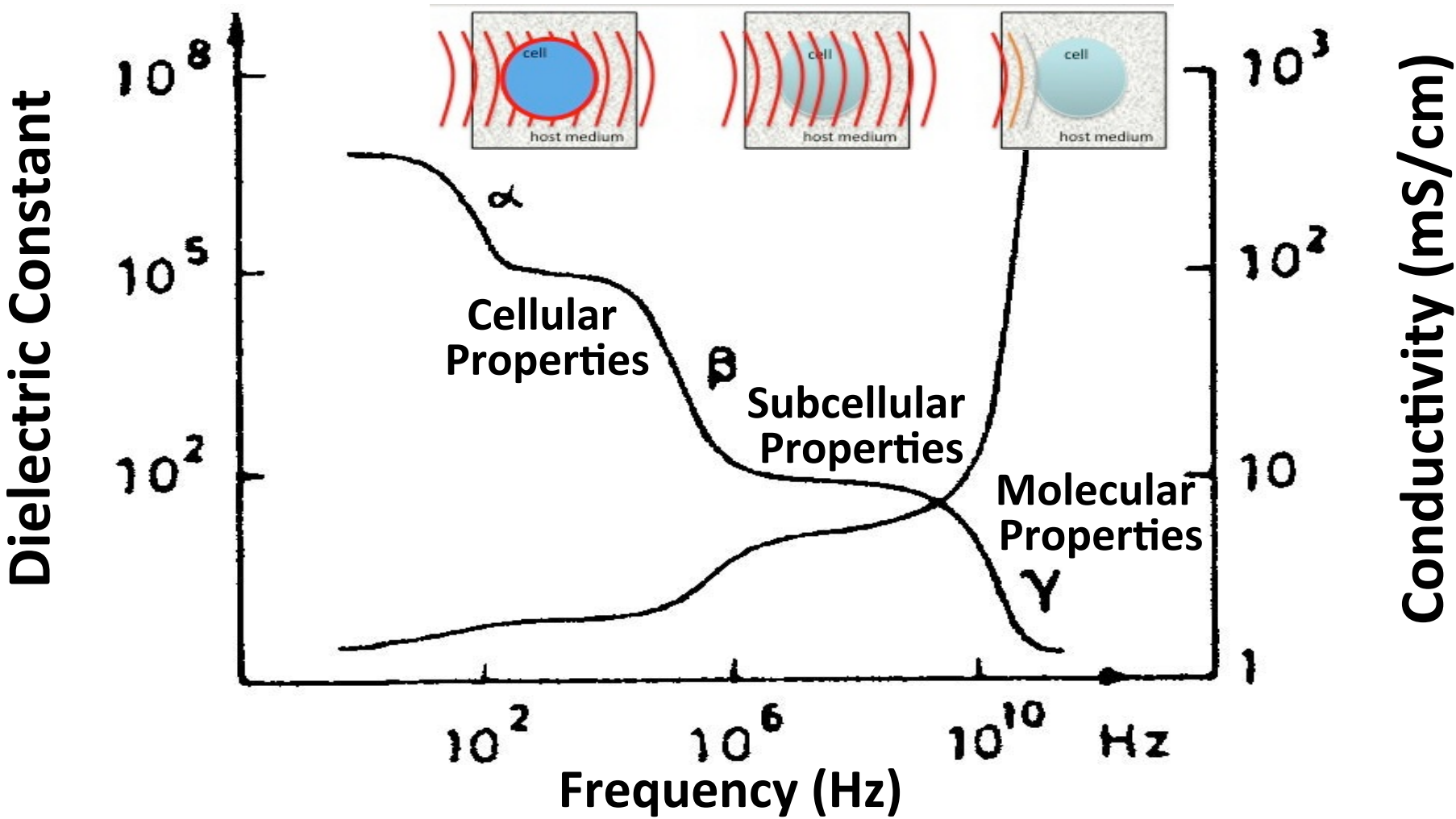

HP Schwan (1985): Hypothesis based on tissue measurement

Broad Band Electrical Sensing

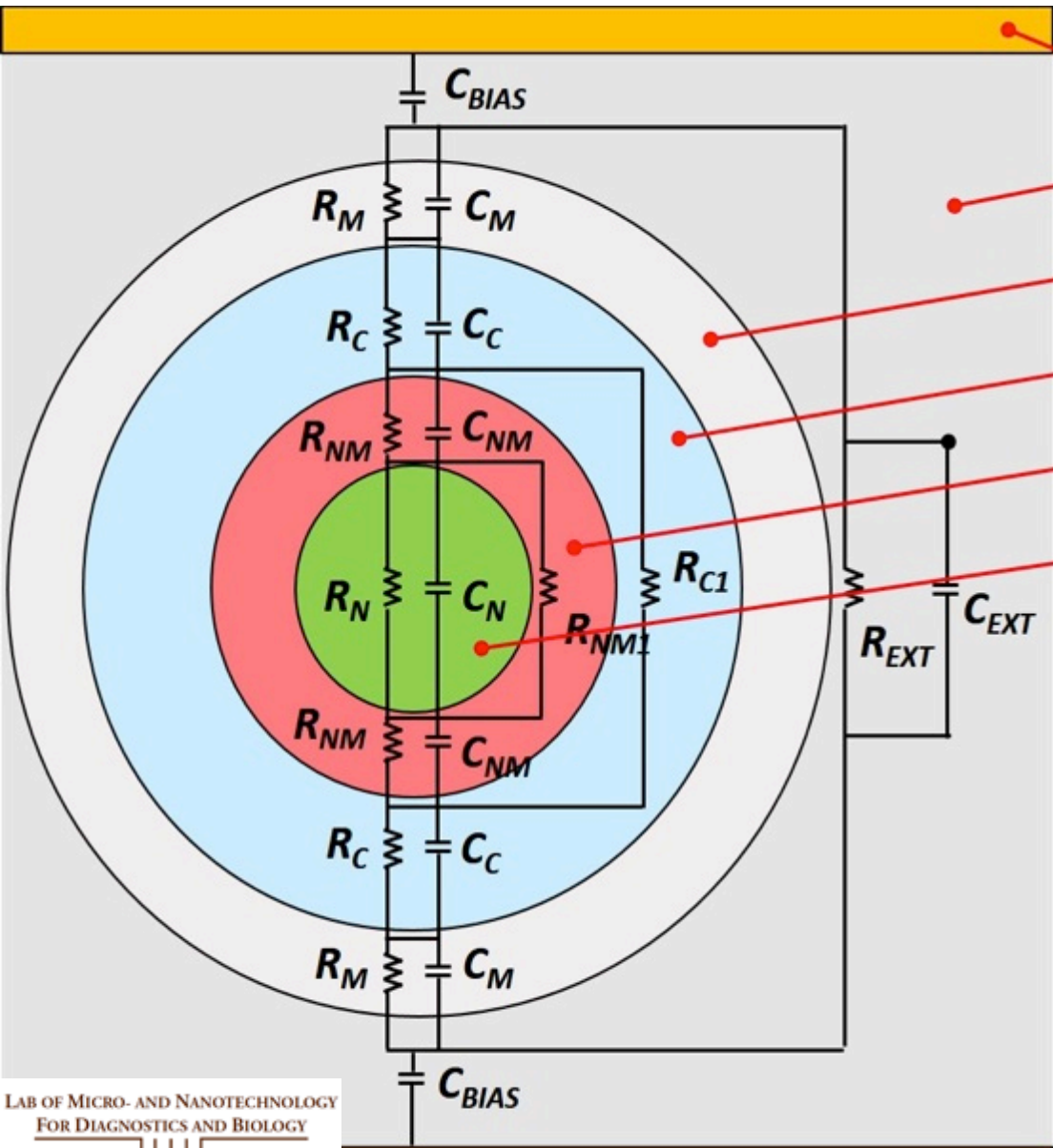

- Electrode
- Solution
- Plasma Membrane
- Cytoplasm
- Organelle/Nucleus Membrane
- Organelle/Nucleus



Experimental Setup

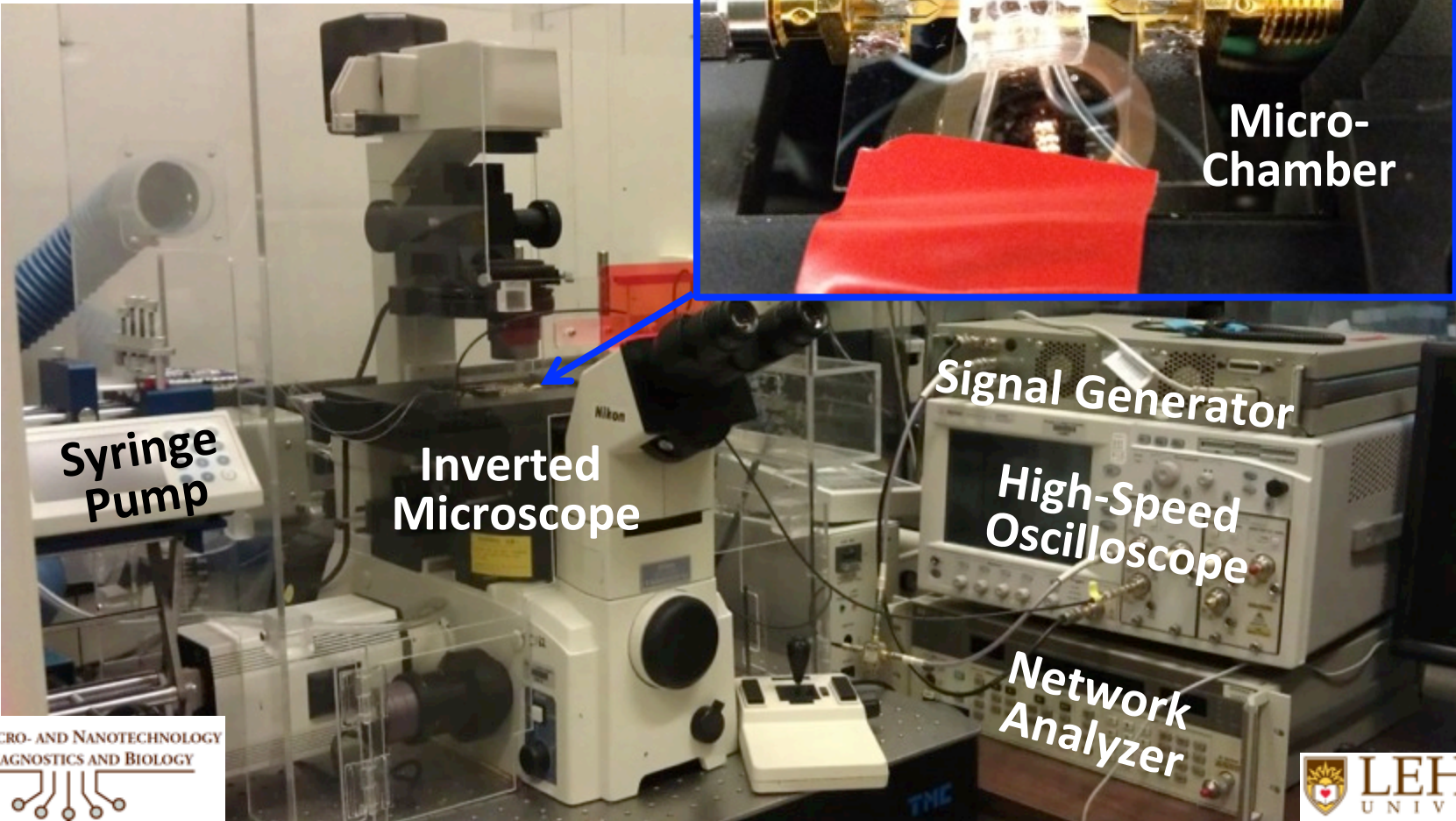
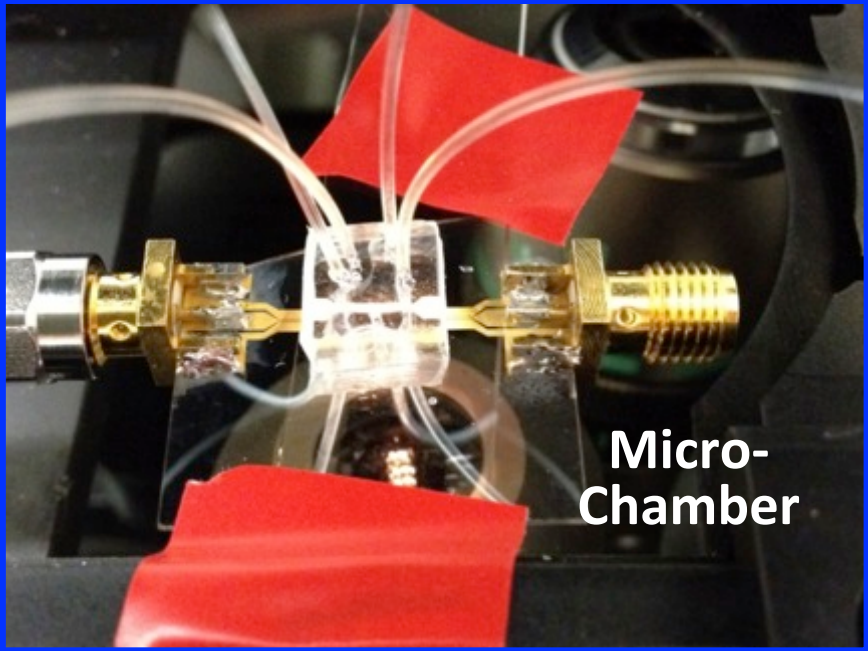
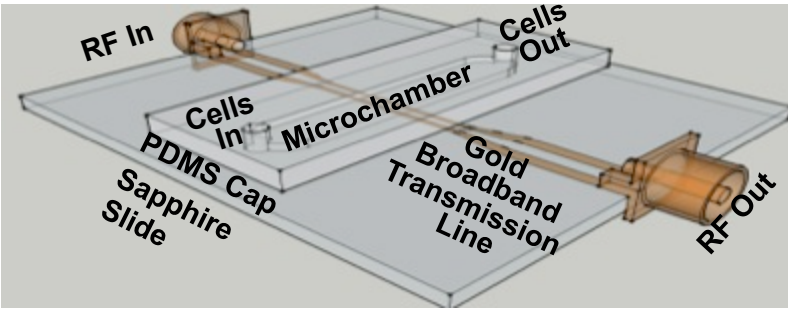

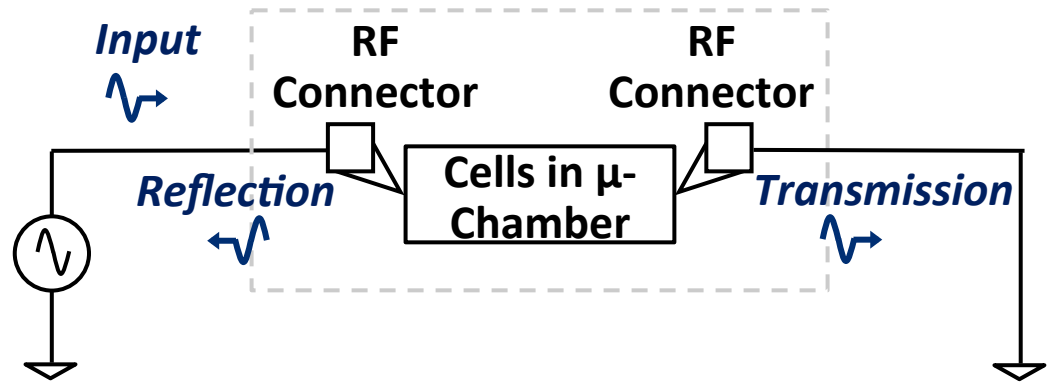
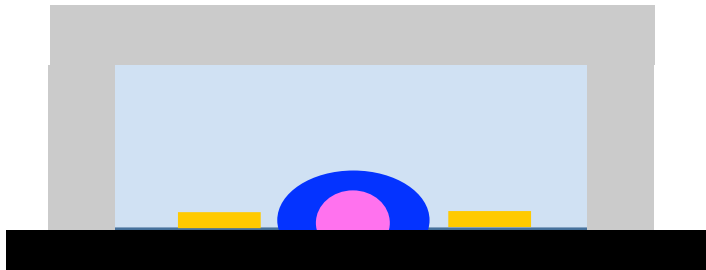
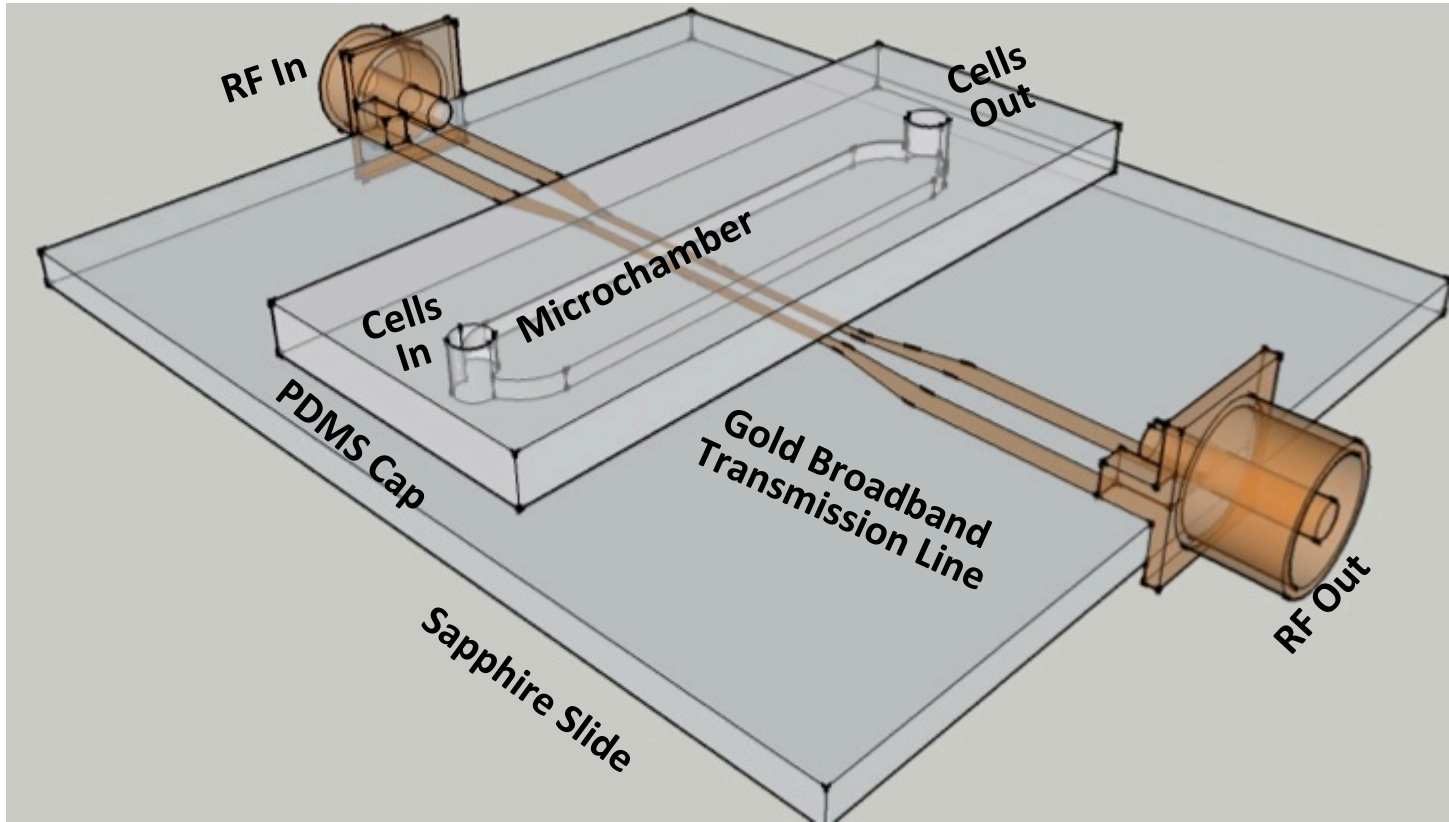

Modeling to Extract Cell Information

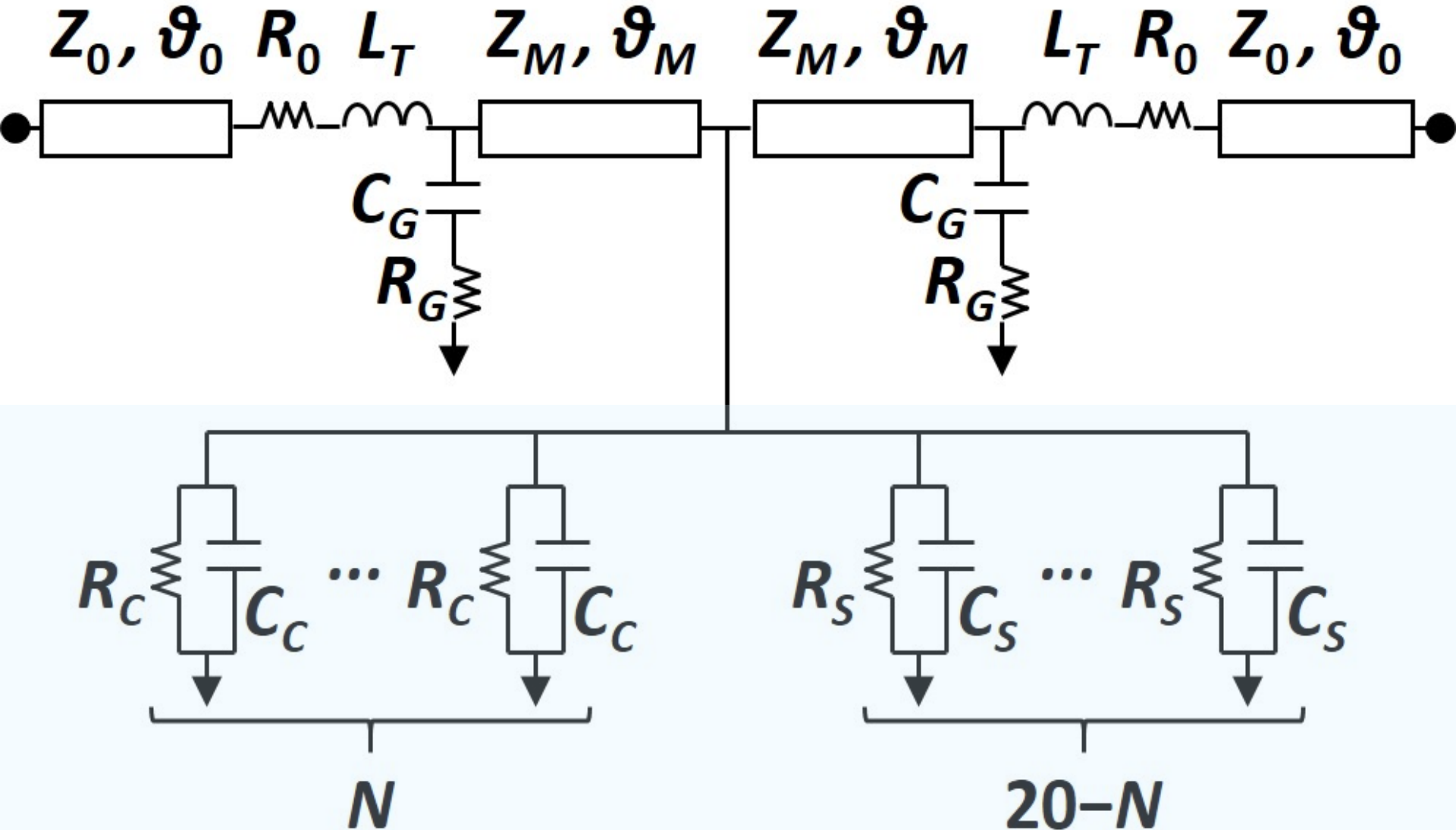

Cell Immobilized by Dielectrophoresis

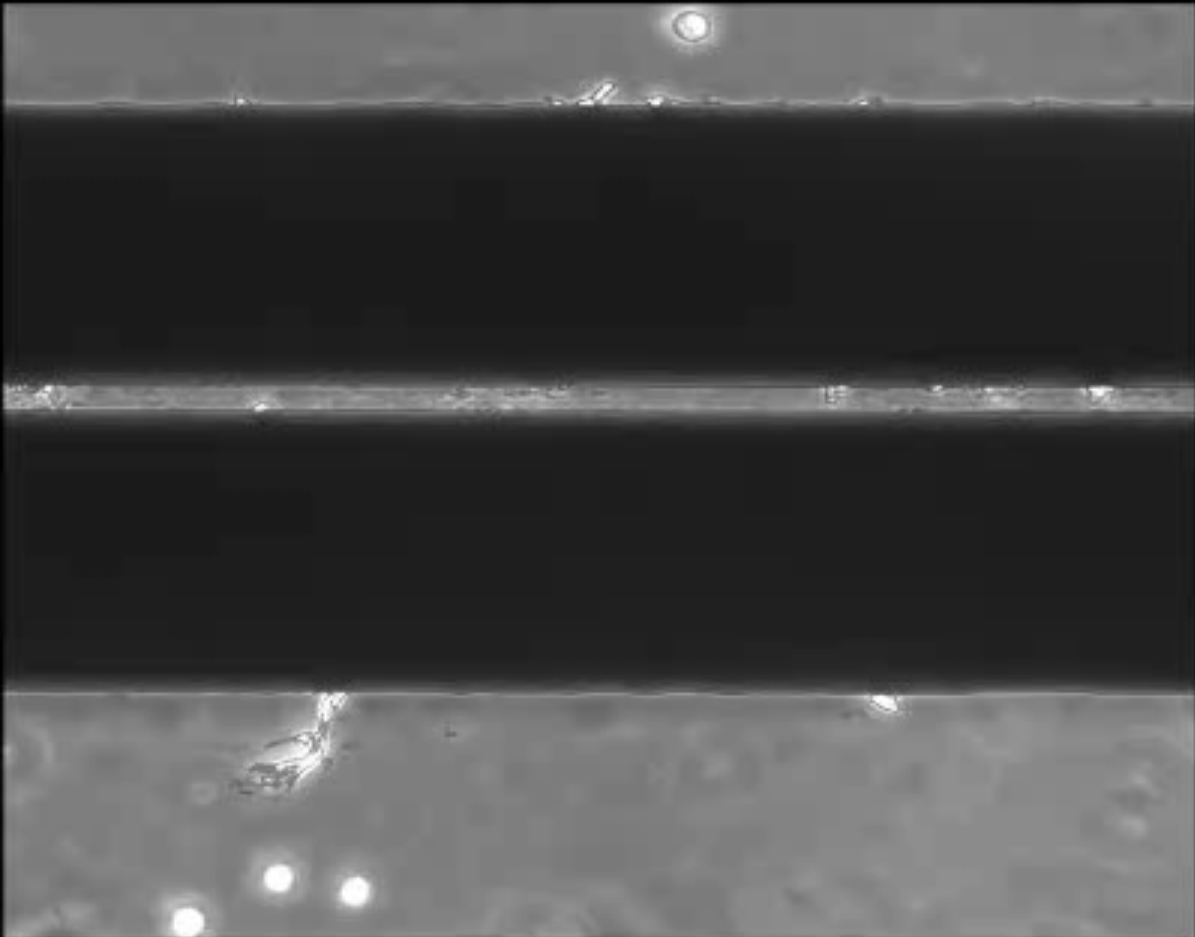

Differentiating Live vs Dead HEK Cells

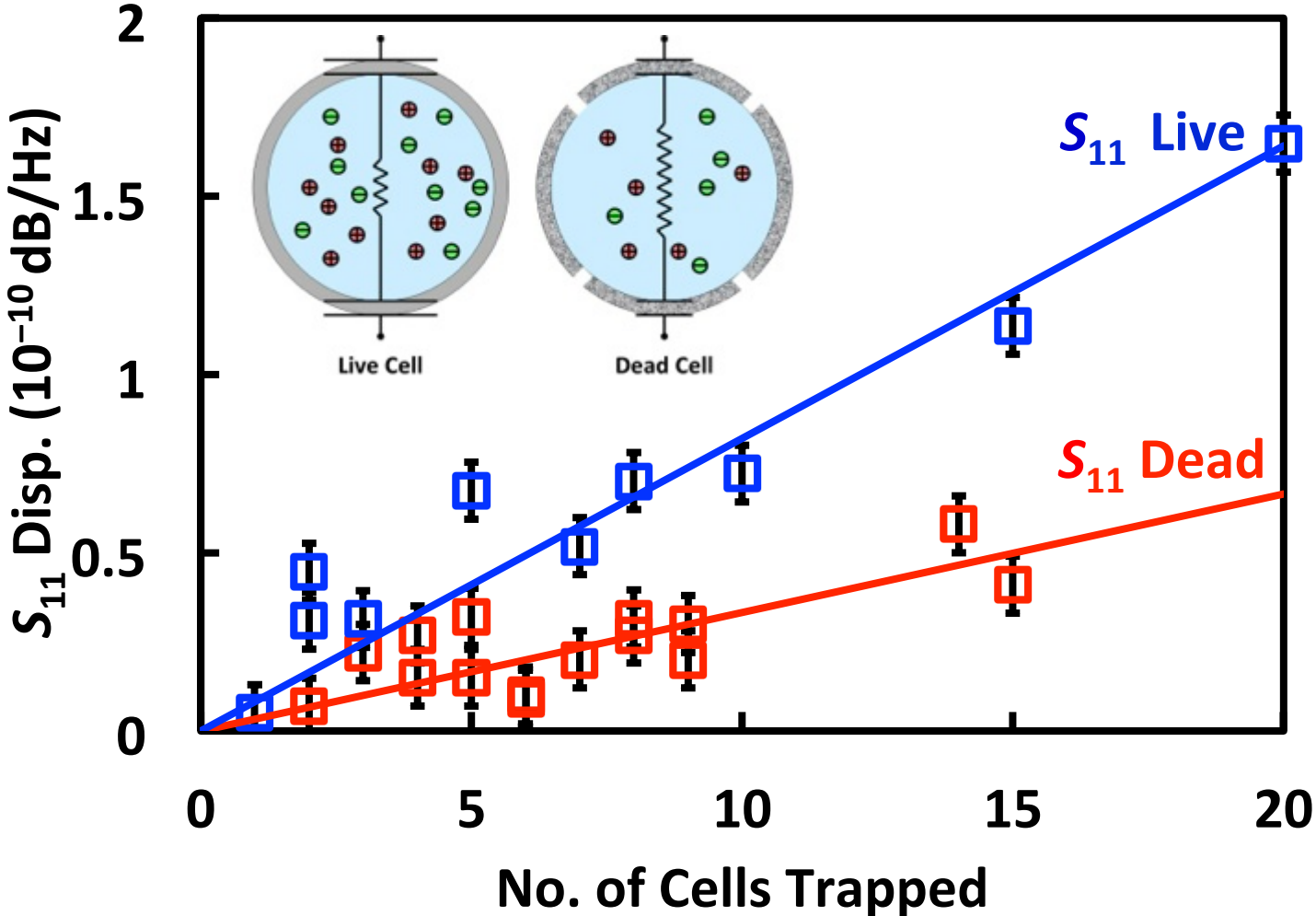

Differentiating Dead HEK and Jurkat Cells

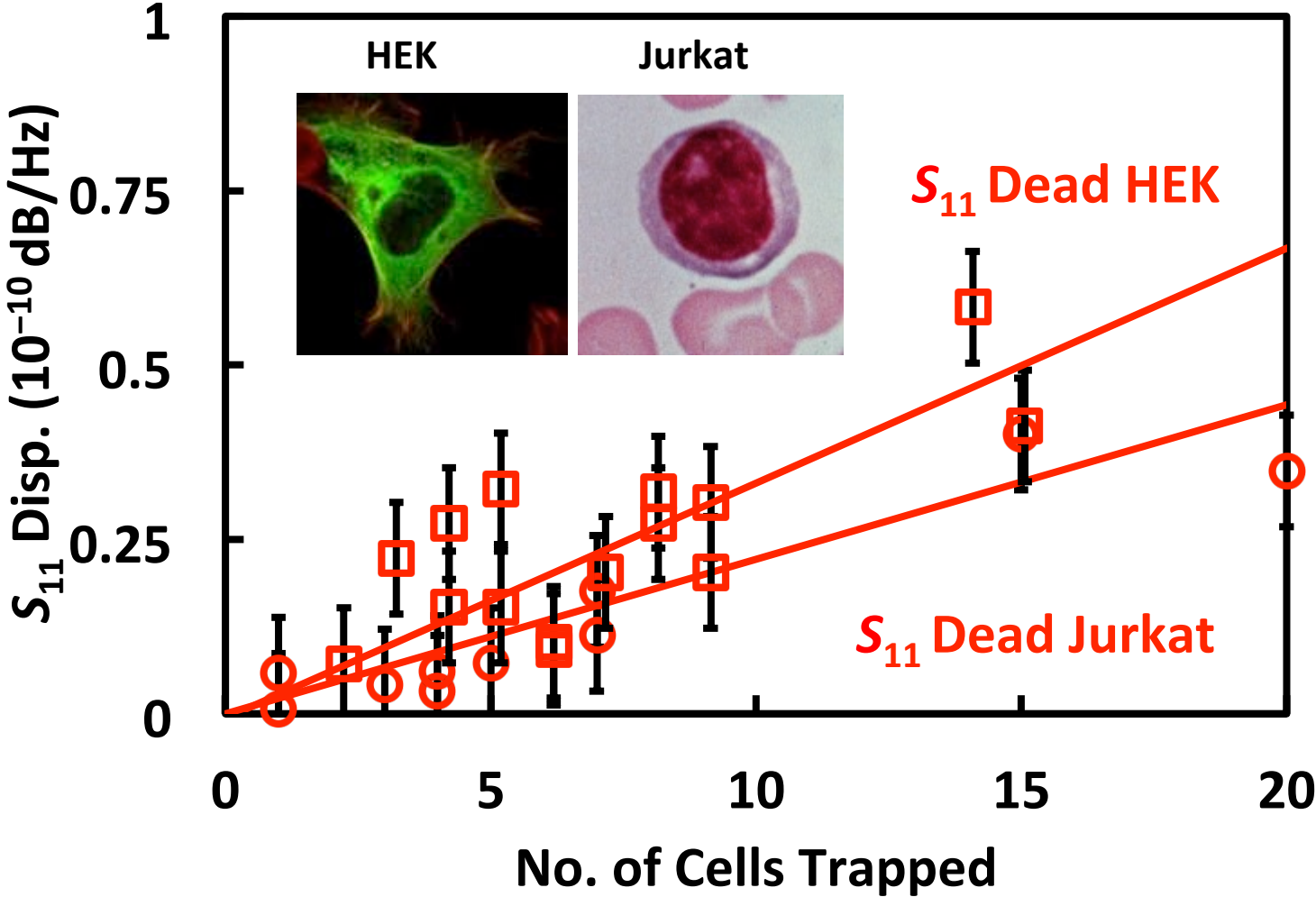

Differentiating Live and Dead E. coli

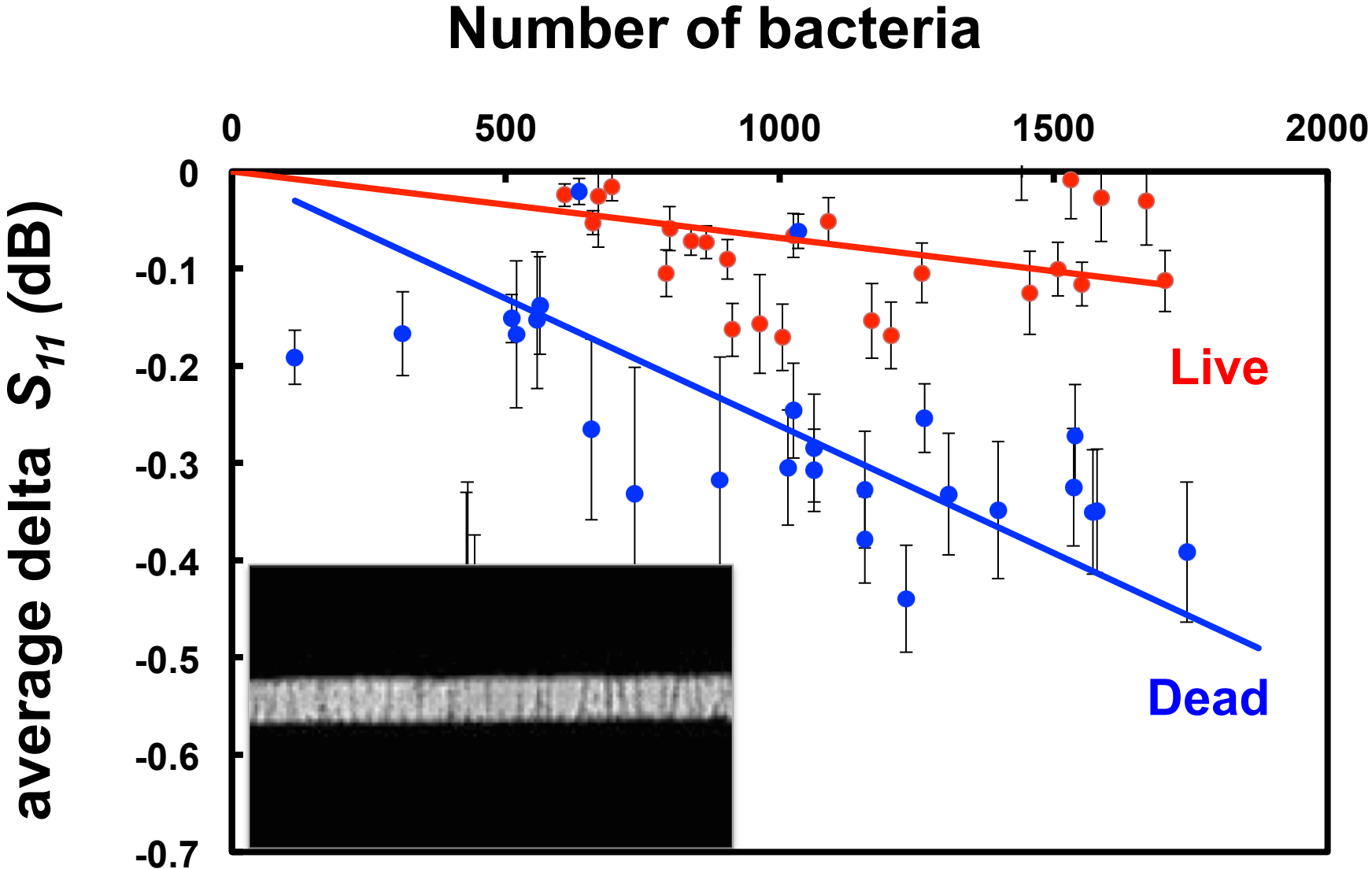

Biofilm Monitoring on a Chip

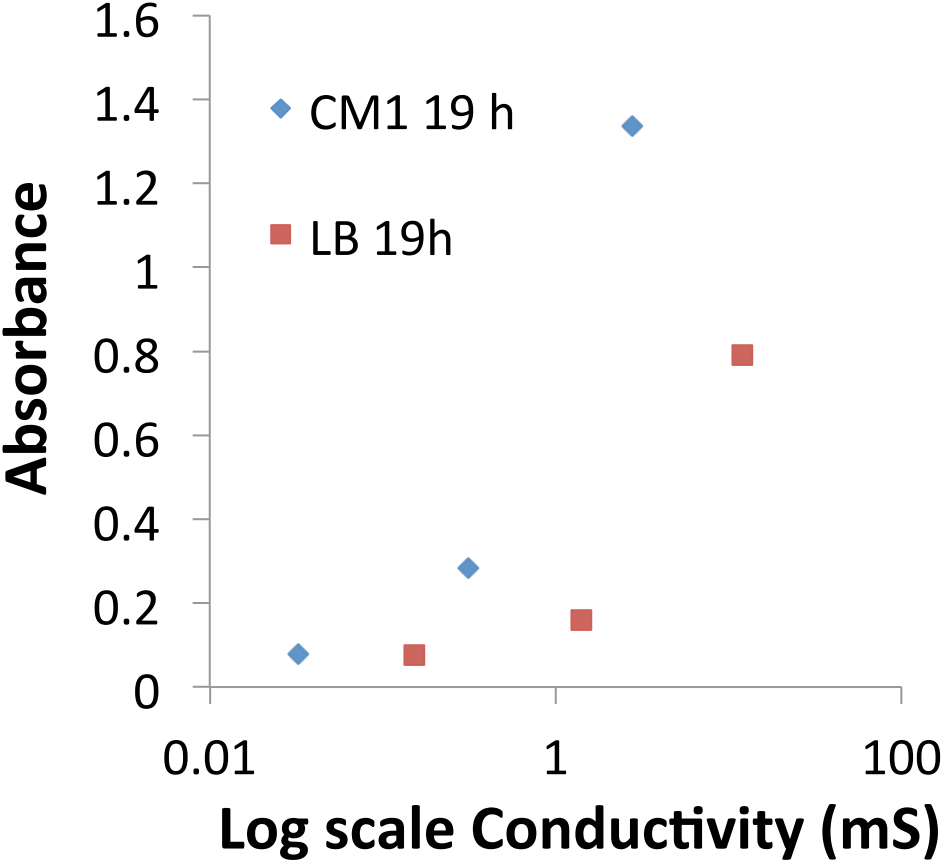
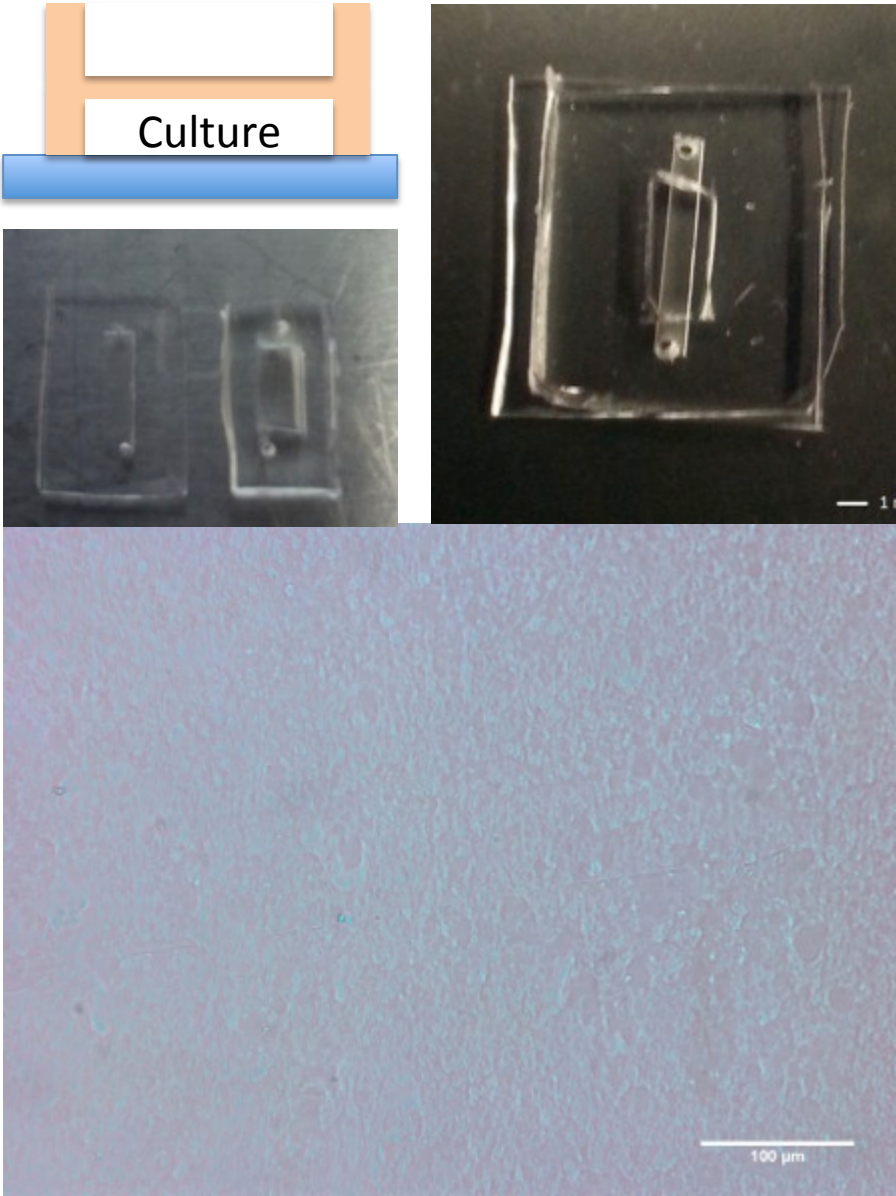

Next Steps

- Monitor biofilm growth on chip
- Screen anti-biofilm reagents

Acknowledgments

Collaborators

Fil Bartoli
Arthur Chiou (Yangming U, Taiwan)
Tim Friel (LVHN)
Martin Hirsch (MGH)
Jim Hwang
Jim Gilchrist
Sabrina Jedlicka
Yaling Liu
Alp Oztakin
Daniel Ouyang
William Rodriguez (MGH)
Olga Latinovic (IHV)
Peikuen Wei (Academia Sinica, Taiwan)
Frank Zhang

Students

Caroline Multari
Krissada Surawathanawises
Bu Wang
Chao Zhao



National Institute of Allergy and Infectious Diseases
Leading research to understand, treat, and prevent infectious, immunologic, and allergic diseases.

DEPARTMENT OF
HEALTH



THANK YOU!
QUESTIONS?

Nanoporous Membrane for Viral Processing and Sensing

- Controllable pore size
- High porosity
- Bio-functionality
- Tight pore size distribution
- Thin membranes

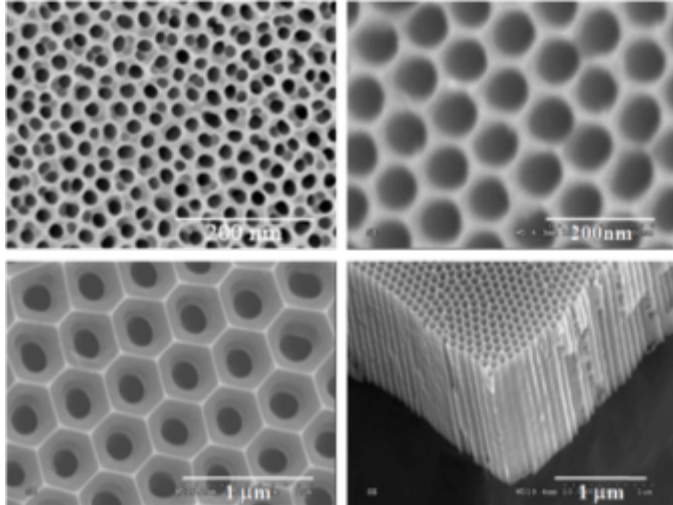
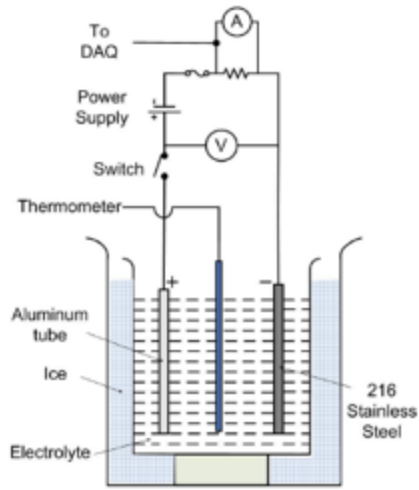
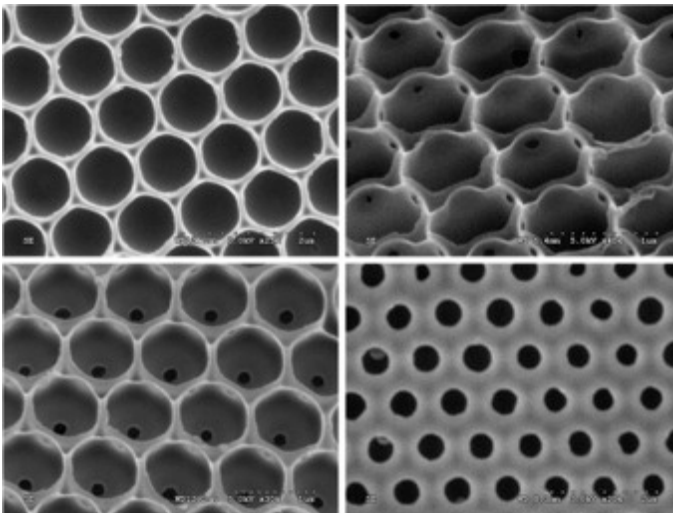
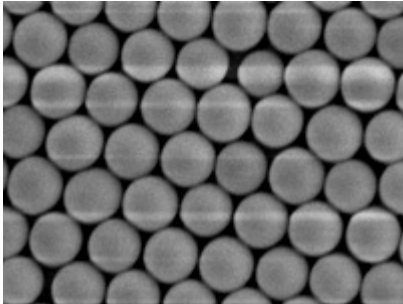

Embedded Nanoporous Membranes for Viral Processing

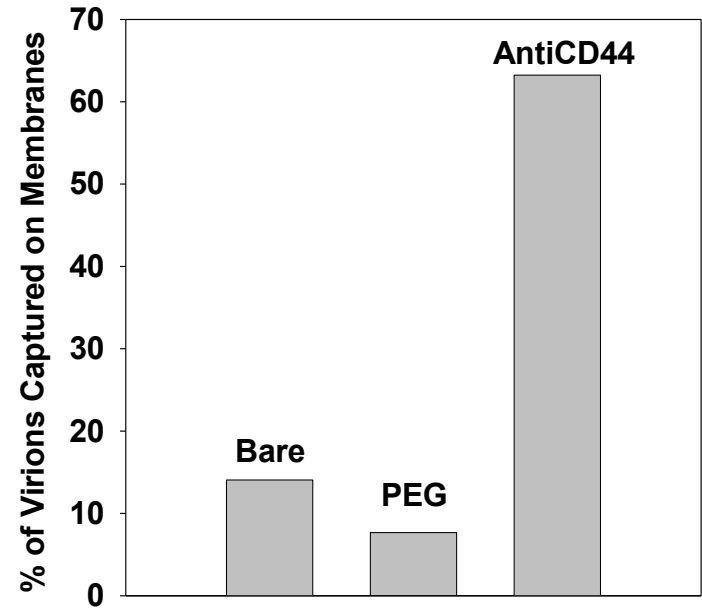
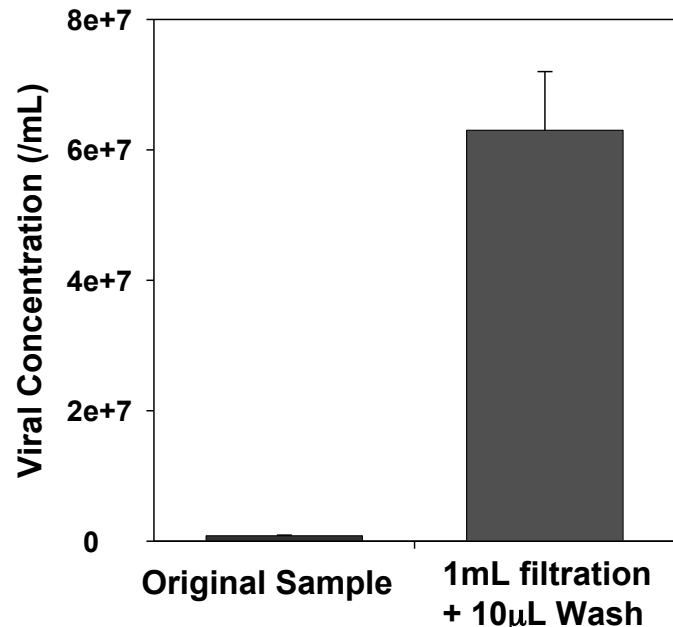
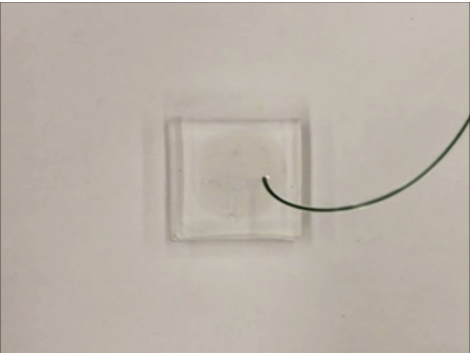
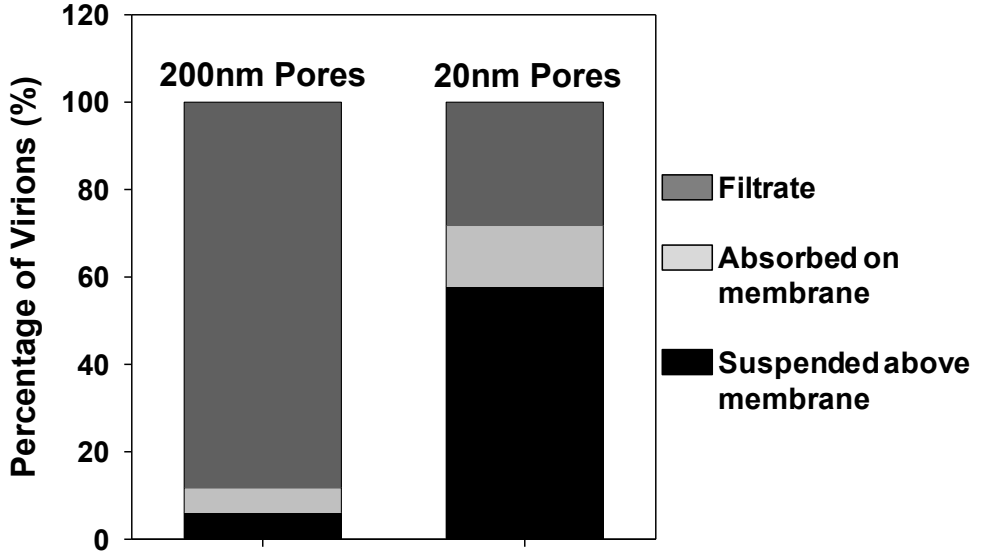
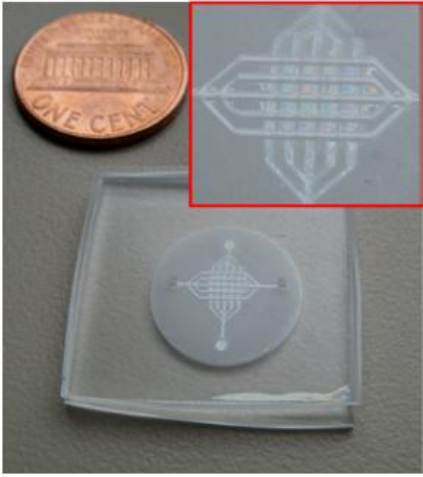

Community-based Care



*Care takes place
in the community.
Reinforced in the
clinic.*

