

CE Customization

User Interface Extensions and Macros
CE 9.8 and RoomOS

With CE Customization you can add custom elements to your Touch10 operated video systems, your DX Series as well as Webex Board user interfaces.

Such user interface extensions may be in-room controls for lights, for curtains or for other peripherals (including one or more video switches to extend the number of video sources available). The interface extensions will then communicate with external control systems to let you obtain the functionality you want.

Macros allow you to write snippets of JavaScript code that can automate parts of your video endpoint behavior.

The fact that the Cisco video system itself and peripherals now can be controlled from the Touch10 and DX Series as well as Webex Boards user interfaces helps providing a consistent user experience throughout the meeting room.

The current version of the CE Customization utility is available for the SX, MX, DX, Room Series Webex Board systems running Collaboration Endpoint Software, software version CE9.8 and for systems running RoomOS.

Note that macros in the SX10 are not supported.

What's In This Document

Part 1

In-Room Control

Definition of Terms	4
In-Room Controls.....	5

Creating a User Interface

Creating a User Interface for the Touch10	7
Launch the In-Room Control Editor	8
A Tour of the In-Room Control Editor	9
Previewing Your Current Configuration.....	10

Application Programming Interface (API)

API for Programming In-Room Controls	12
--	----

Widgets

Overview of Widgets.....	17
Switch	18
Slider	19
Button.....	20
Group Button.....	21
Icon Button.....	22
Spinner.....	23
Text	24
Directional Pad	25
Spacer.....	26

Removing Default Buttons

Removing Default Buttons.....	28
An Out-of-Call Example	29
An In-Call Example	30

Command Reference

Events	32
Commands.....	34
Statuses	35

Creating Interactive Messages

How Interactive Messages Work (I)	37
How Interactive Messages Work (II).....	38

HTTP(S) Requests^{REVISED}

Sending HTTP(S) Requests	40
--------------------------------	----

Troubleshooting

Tips When Troubleshooting	42
---------------------------------	----

Tips and Tricks

Recommended Best Practice	44
Granting Access to In-Room Control Editor and Extensions API.....	46

Part 2

Room Simulator

Running the Simulator.....	48
----------------------------	----

Part 3

Use of a Video Switch

Using a Third-party Video Switch to Extend the Number of Video Sources Available	50
Command Details.....	51
Video Switch Example	52

Part 4

Working with Macros

Creating Macros.....	54
The Macro Editor Panel.....	55
Things to Observe.....	56

Part 5

Incorporating Third-party USB Control Devices

About the USB Control Device Functionality.....	58
Example on the Use of a Third-Party USB Input Device.....	59

Part 6

Audio Console

Customizing the Audio Connections.....	61
The Audio Console Panel.....	62

On the Use of This Guide

When reading this document on javascript enabled devices, the entries in the table of contents are all hyperlinks. You can click on them to go to the topic.

Product Documentation

User guides, compliance and safety information for Cisco TelePresence systems are available at <https://www.cisco.com/go/telepresence/docs>

For Cisco Webex registered devices, go to <https://help.webex.com>

Specific links to other guides:

<https://www.cisco.com/go/sx-docs>
<https://www.cisco.com/go/mx-docs>
<https://www.cisco.com/go/dx-docs>
<https://www.cisco.com/go/room-docs>
<https://www.cisco.com/go/board-docs>

Cloud registered devices:

<https://help.webex.com>

We recommend that you visit the Cisco web site regularly for updated versions of this guide.

Who Has Access to the Editor?

In order to access the In-Room control editor you will need to have administrator rights.

However, an administrator may create an In-Room Control User account. With this account it is possible to log into the codec to run the In-Room Control Editor. No other part of the web interface is accessible from this account.

If you use SSH to log into the codec, only a very limited set of the API will be accessible.

Part 1 In-Room Control

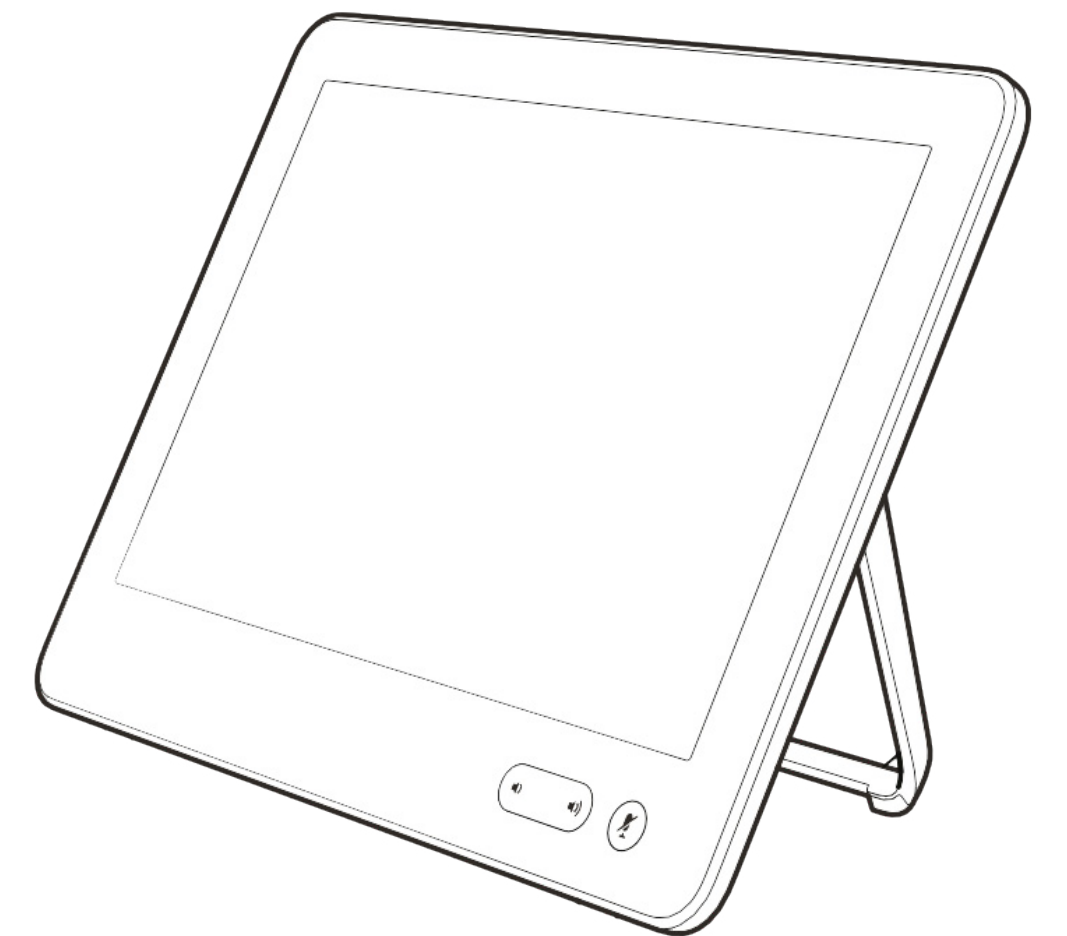

Definition of Terms

What Is In-Room Control?

The following terms will be used throughout this document:

Video system. Video system or codec in the Cisco TelePresence MX Series, SX, DX Series and Webex Board running Collaboration Endpoint Software, version CE9.8 or later, as well as systems running RoomOS. Sometimes all these referred to as video devices. Newer versions of the the CE software will be required to achieve full functionality for future versions.

Control system. Third-party control system with hardware drivers for peripherals, for example Crestron, AMX, Raspberry Pi.

Touch10. Our touch-based control device for the MX Series and SX Series video systems. Full product name: Cisco TelePresence Touch10. Also known as Touch10 controller, Touch10 user interface or Touch10 panel.

In-Room control panel. Panel with controls for third-party peripherals in the room. The panel opens when you tap the corresponding in-room control icon in the status bar on Touch10. See the [Create a user interface chapter for more on this.](#)

In-Room control editor. Our easy to use drag-and-drop editor for making in-room control panels.

xAPI. The bidirectional API of the video system. The xAPI allows third-party applications to interface with and interact with the video system, and vice versa.

Widget. User interface element, for example buttons, sliders, and text fields, that you can use to build an in-room control panel for Touch10.

With In-Room Control you can add custom elements to our Touch10/DX/Webex Board user interfaces. Such *user interface extensions* may be controls for lights or blinds, or other peripherals (including one or more video switches to extend the number of video sources available) all controlled by external control systems.

Since both the Cisco video system and the other peripherals now are controlled from the systems' user interfaces, you will get a consistent user experience throughout the meeting room.

The version of the In-Room Control feature described in this document, is available for the MX, SX (macros not for SX10) and DX Series video systems running Collaboration Endpoint Software, version CE9.8 or later, as well as for systems running RoomOS.

You can customize the Touch10/DX/Webex Board user interface to allow control of peripherals in a meeting room, for example playback of a sound or movie source, lights and blinds.

You can also add content sensitive controls appearing only when in a call and/or only outside calls.

Although the maximum number of panels is unlimited, observe that for all practical purposes the maximum number of panels will be set by usability requirements and, to some extent, the system resources.

Each button you introduce on the Touch10/DX/Webex Board will need a corresponding panel unless you opt for applications like speed dialing and one button to push. For these cases you will prefer an action without an associated panel. For more on this, see the Tip in “A Tour of the In-Room Control Editor” on page 9.

If there is not enough space left on the screen, a **More...** button will appear to provide access to the rest of the buttons.

This means that altogether you have three sets of panels at your disposal:

- **Always** icons (buttons), visible at all times.
- **Outside calls only** icons (buttons), visible outside calls only.
- **In-Call only** icons (buttons), visible during calls only.

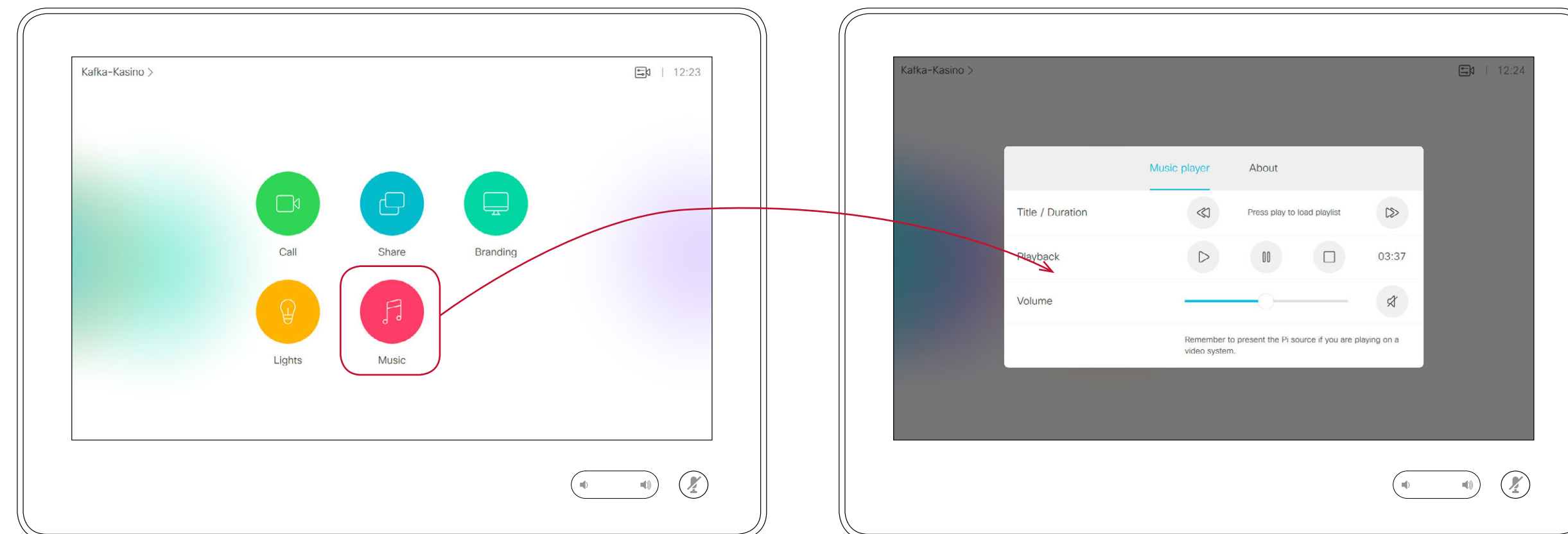

Examples of how customization made by means of In-Room Control may appear on the Touch10, with an icon as shown at left and the menu appearing when that icon has been tapped, allowing control of music player, as shown at right.

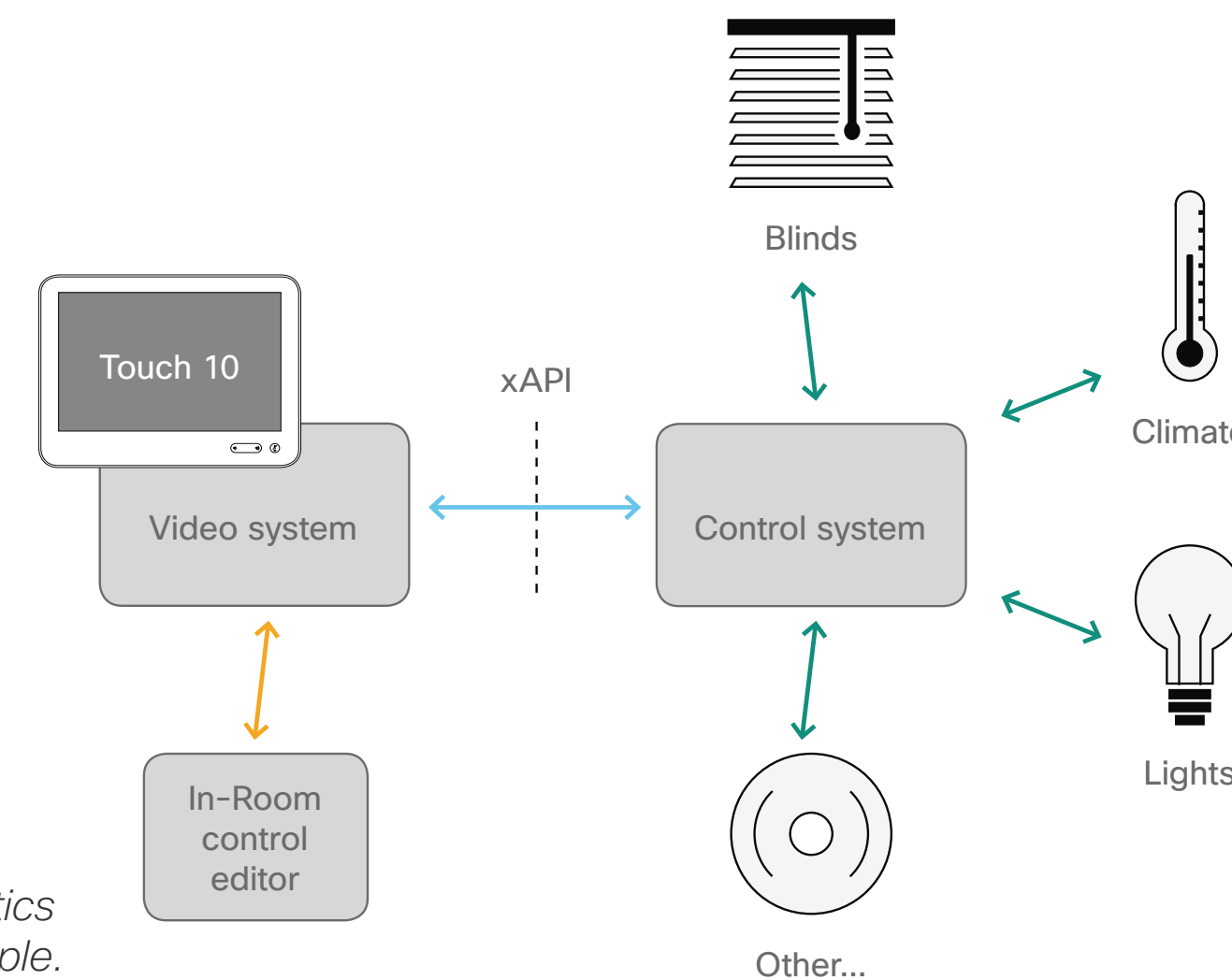

In-Room Control schematics using Touch10 as example.

To utilize the features of the In-Room Control you will need a Cisco video system with a Touch10/DX/Webex Board user interface, and a third-party control system, for example Crestron, AMX.

The video system’s API, referred to as the xAPI, is the link between the video system and the control system. Use the events and commands exposed by the xAPI when you program the control system.

The simple drag-and-drop editor offers a library of user interface elements, referred to as widgets. You can use these widgets to create your own in-room control panel for the Touch10/DX/Webex Board user interface.

Together, all of this provides a powerful combination of the control system’s functionality and the user-friendly Touch10/DX/Webex Board user interface.

Note! All examples in this document show Touch10 user cases only, but this should not cause major difficulties due to the high degree of similarity between the interfaces.

Creating a User Interface

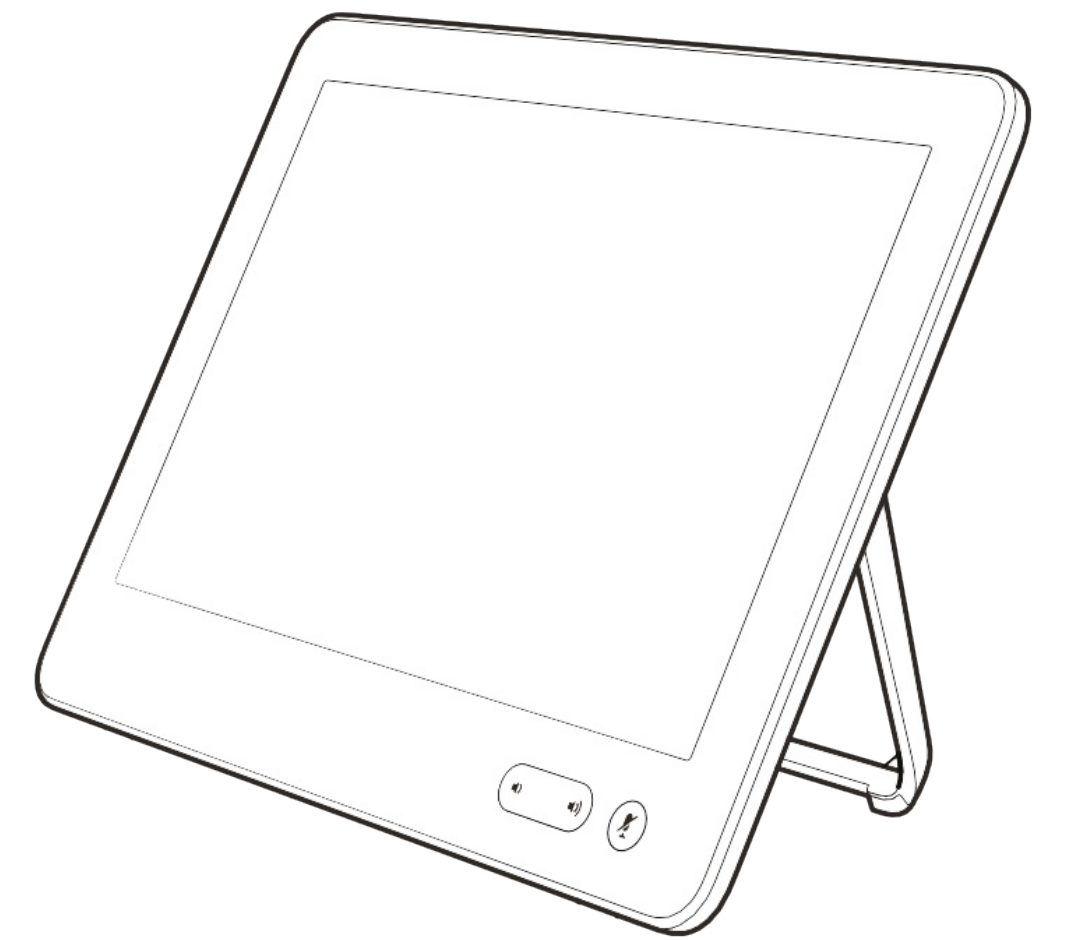

Creating a User Interface for the Touch10

Shared file format

Use the In-Room Control Editor to create customized panels for peripheral controls on the video system's Touch10/DX/Webex Board user interface.

Connected to the Video System

If you have access to the video system, you can launch the editor from the video system's web interface.

If an in-room control panel already has been created on the system, this will automatically load into the editor, ready to act as a starting point for your design.

When you push a new panel to the video system, you will immediately see the result on the Touch10/DX/Webex Board screen.

Offline

There are two places you can download the offline editor from:

- Download from <http://www.cisco.com/go/in-room-control-docs>
- Or, sign in to a video system's web interface with administrator credentials, navigate to **Integration > In-Room Control**, and click **Download Editor**.

If you choose to download the offline editor, extract the files from the downloaded zip-file. Retain the folder structure.

When using the offline editor you will be working with files, rather than communicating directly with the video system. Apart from this, the offline editor has full functionality.

The editor that you launch from the video system's web interface and the offline editor share the same file format, so files created in one version can be opened and modified in the other.

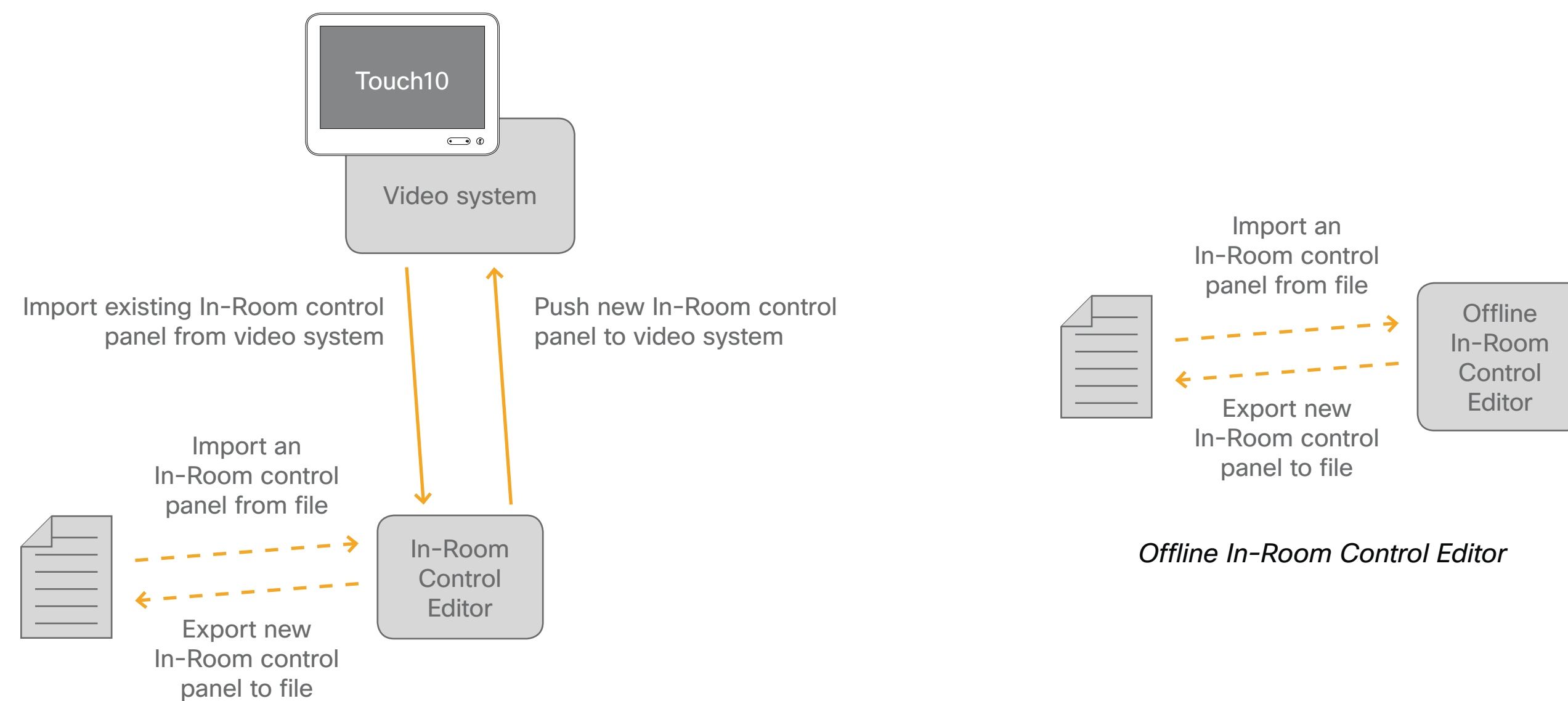

In-Room Control Editor launched from the video system's web interface

Launch the In-Room Control Editor

Sign in to the video system's web interface with administrator credentials, navigate to **Integration > In-Room Control**, and click **Launch Editor**.

If there is a set of in-room control panels on the video system already, it will load automatically into the editor. The Create icons (as in the below example) will then read Edit wherever a panel has already been created.

Offline version. If you are using the offline version of the editor, use a browser to open the **index.html** file that you find in the **rceditor** folder.

With no panels already defined, the user interface will look as shown at right.

Click on **+** as indicated by the text **Add your first panel**.

The first panel will be of the **Home** panel type (see the previous pages for more on this). You can change this—see the next page for more.

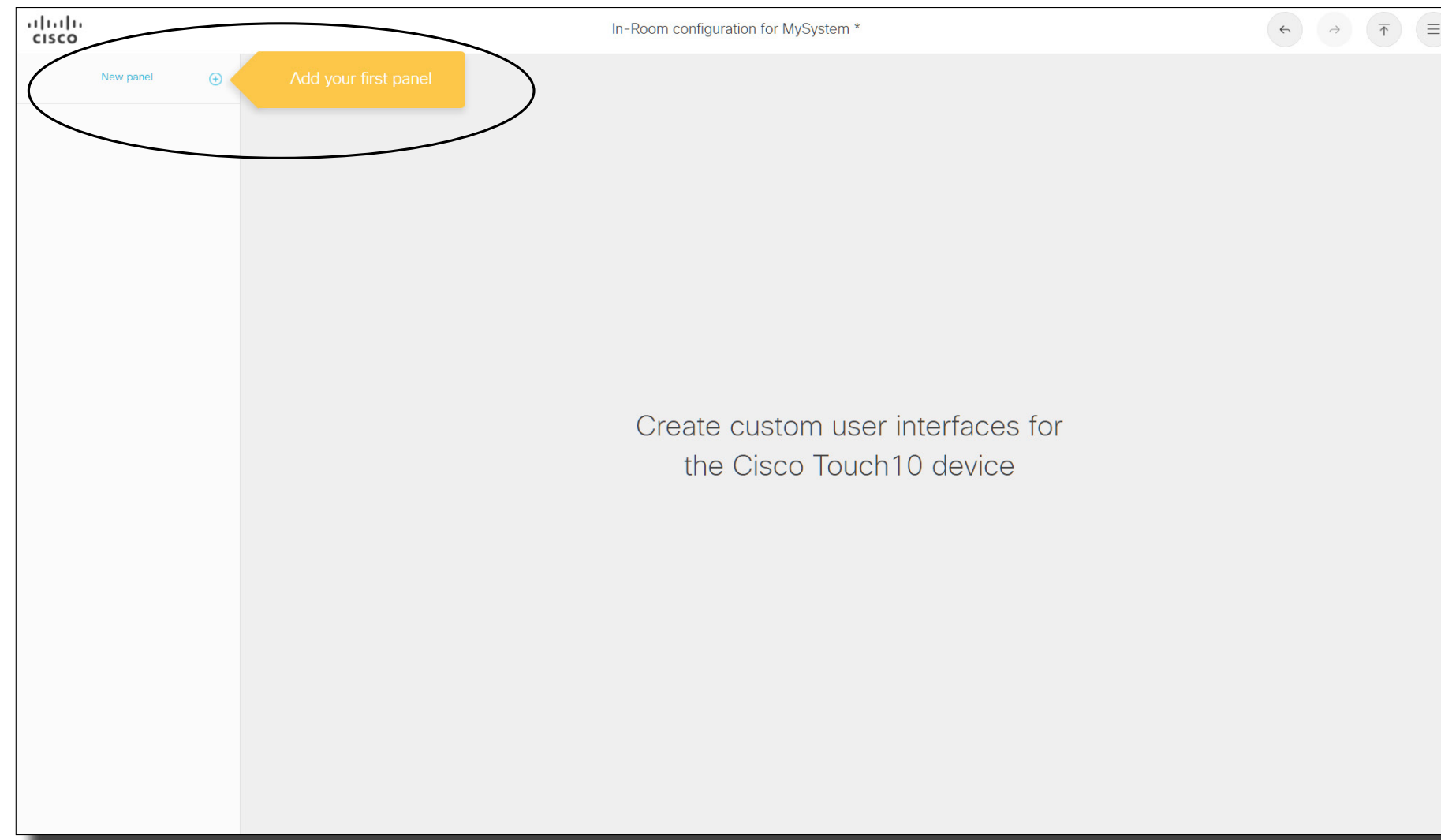

A Tour of the In-Room Control Editor

Use the arrow keys of the Panel position (in Panel properties) to shift the position of a specific panel in the sequence up or down. This will determine the order, in which the buttons appear on the screen.

The Panel button name, color and icon appears here. To change the name, click on the text to make it editable. To specify color and icon use the Properties panel.

Create new panel from here.

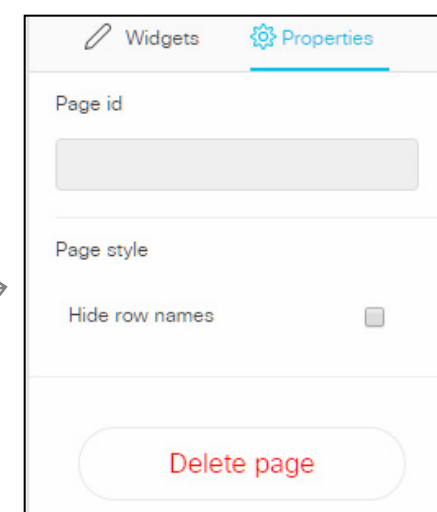

Page properties are accessed by clicking here.

Preview your current configuration, see also the following page.

Undo, Redo and Export configuration to video system.

More options

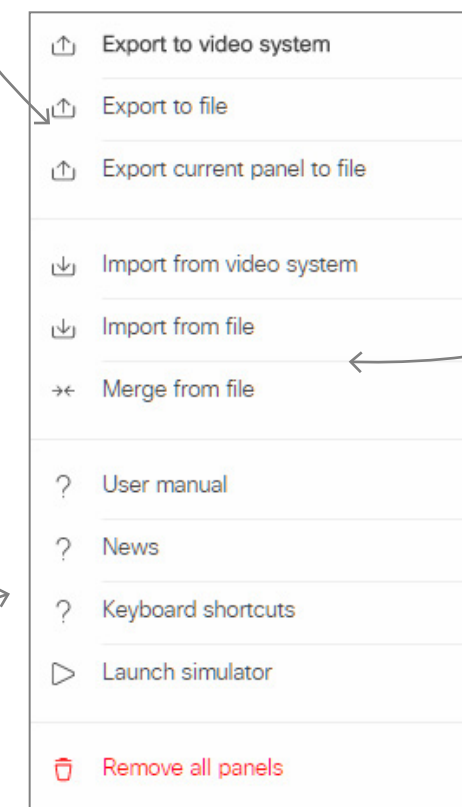

Entire sets of panels, or just a single panel can be exported to file for later use.

When importing from file, choose between Import and Merge. Merge will append panels to current set of panels. Any panels with the same name will then be overwritten.

This controls the width of a widget. Width sizes available will depend on widget type.

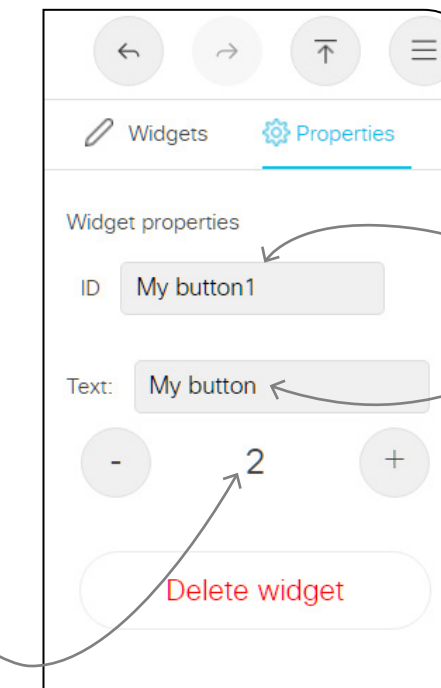

ID is used to refer to a widget.

Text is what appears on the screen.

The properties panel will display settings for any part selected/highlighted by the yellow frame. Such a selection can be Panel, Page, Row or Widget.

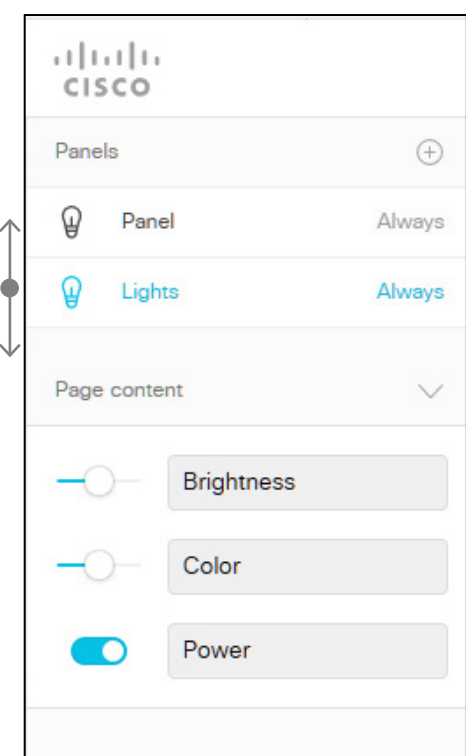

The Widget IDs shown above belong to the active panel (indicated by text in blue).

Once you start to populate a page of a panel, the widget IDs in use will appear as shown above to provide a simpler overview.

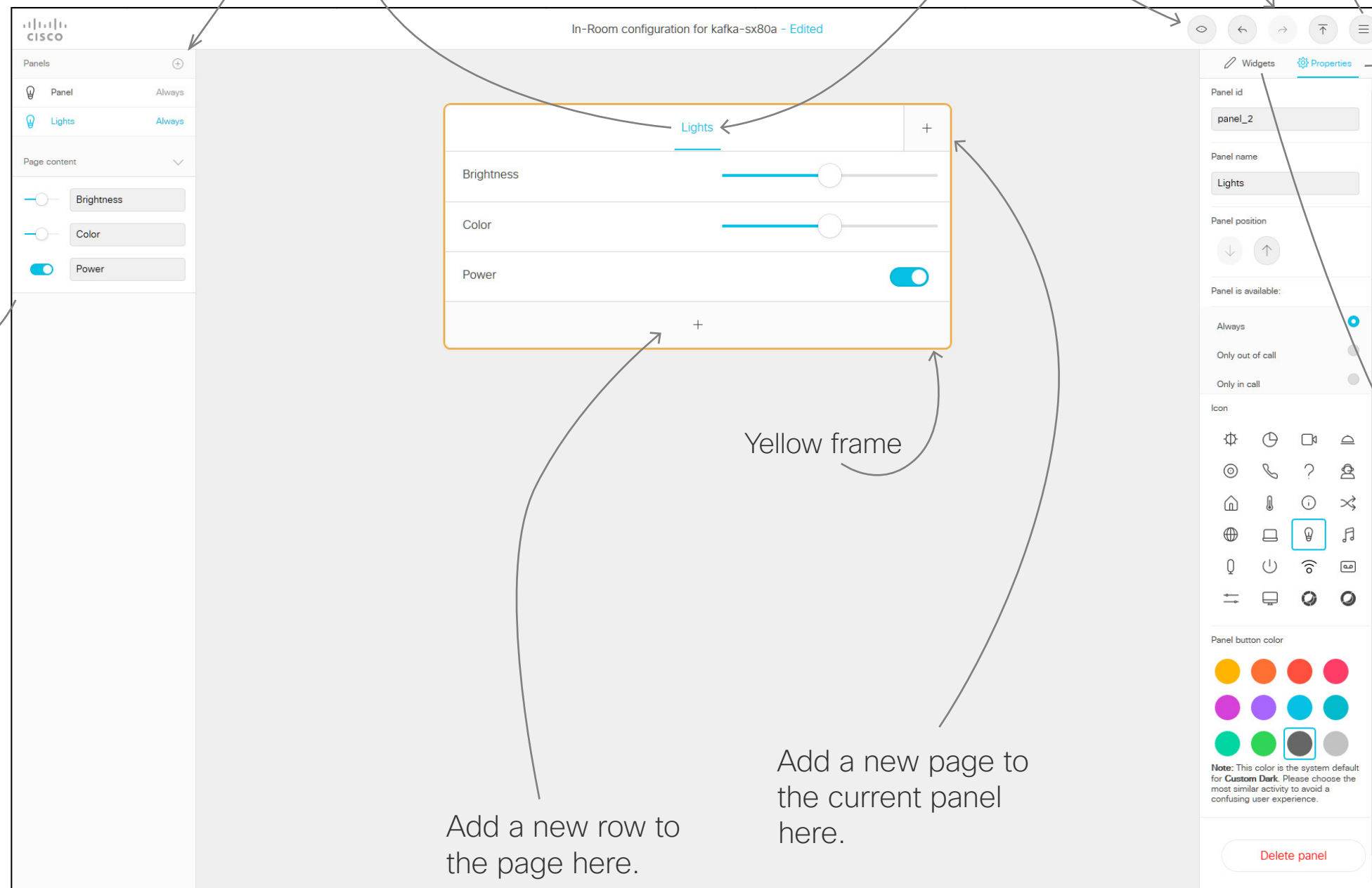

Yellow frame

Add a new row to the page here.

Add a new page to the current panel here.

Tip! In addition to clicking the Undo and Redo icons, you may also use the familiar keyboard shortcut commands to copy and paste (**CTRL C & CTRL V / CMD C & CMD V**).

Drag widgets onto the page to populate it.

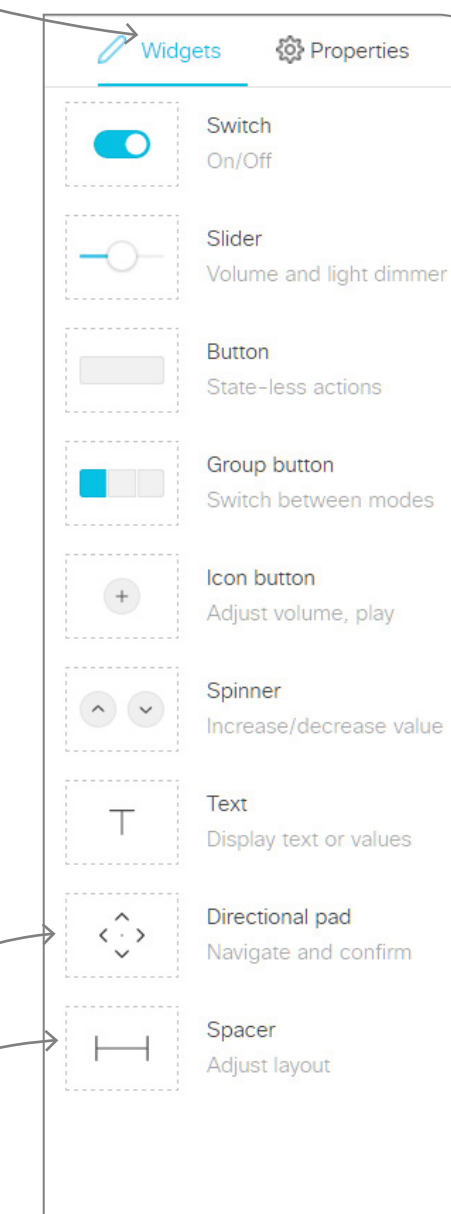

The spacer helps you get a better layout.

The Directional pad can be used to control e.g. Apple TV.

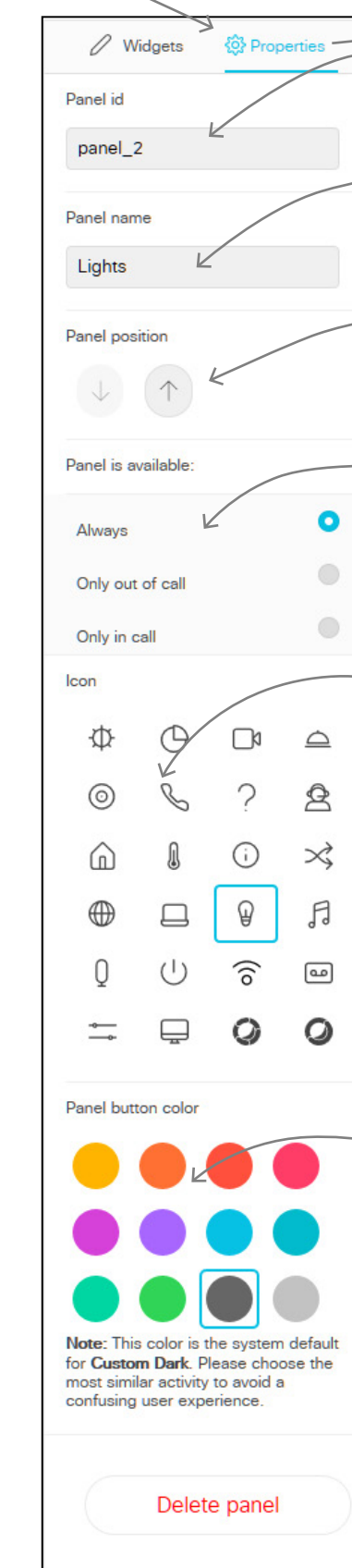

The panel ID.

The panel name

Use these to change the order of the panels, see more about this in the text at top left.

Specify when the panel shall be available.

The icon chosen here will be the one that appears on the In-Room Control button for that panel on the screen.

You may specify the color of an In-room Control button appearing on the screen. A limited color palette used for standard buttons is available in the editor. When you select a color, a small description of the context in which this color is used by Cisco, will be provided, as shown.

The maximum number of panels has now been increased to 20. A practical limit will be set by usability and, to some extent, the system resources. Each button you introduce on the Touch10/DX/Webex Board will need a corresponding panel. Exception: see tip below. A panel will belong to one of the three following groups:

- **In-call only** (visible during calls only)
- **Outside calls only** (visible outside calls only)
- **Always** (visible at all times)

If you create more buttons than the Touch10/DX/Webex Board can accommodate, a button called **More** will be created to give access to the excess buttons.

Boards only: **NEW** To produce **In-call only** buttons on the board during a call, tap the screen. To produce **Always** buttons during a call, tap the **Home** button.

DX only: **NEW** Tap the screen during a call to produce the buttons.

An in-room control panel can be arranged in pages. Each page consists of one or more rows, which you can populate with text and user interface elements known as widgets.

The maximum number of pages per panel is 50.

Widgets are arranged in a four-column grid. The widgets are placed into the grid according to the following rules:

- A widget fills between one and four columns depending on its size.
- Rows are right-aligned.
- If you add more widgets than fit in one line, widgets wrap to a new line within the same row.

Tip: Want to have a button that creates an event, but shows no page? **NEW BEHAVIOR**

Create a new panel, and follow the on-screen instructions. Typical applications for this behavior could be **Speed Dial Buttons** or **One Button to Push**.

Previewing Your Current Configuration

You may preview your configurations to verify them before deploying them.

Note! In order to get a realistic preview of your configurations, you must launch the Simulator before you run the Preview described here. Otherwise the simulator will behave as if no control system is attached.

For the Preview to run successfully, just launch the Simulator. No further setup of the Simulator is needed. If the **Simulator config** has already been loaded into the Simulator, make sure you restore the Codec settings before you run the Preview. See “Running the Simulator” on page 48.

Click here to start the preview.

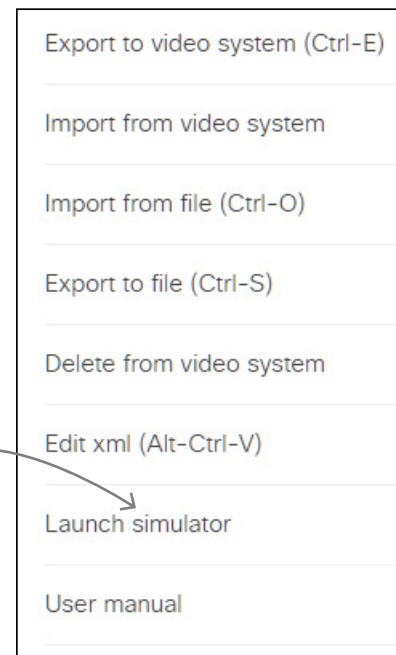

Simulator can be launched directly from the More (≡) menu.

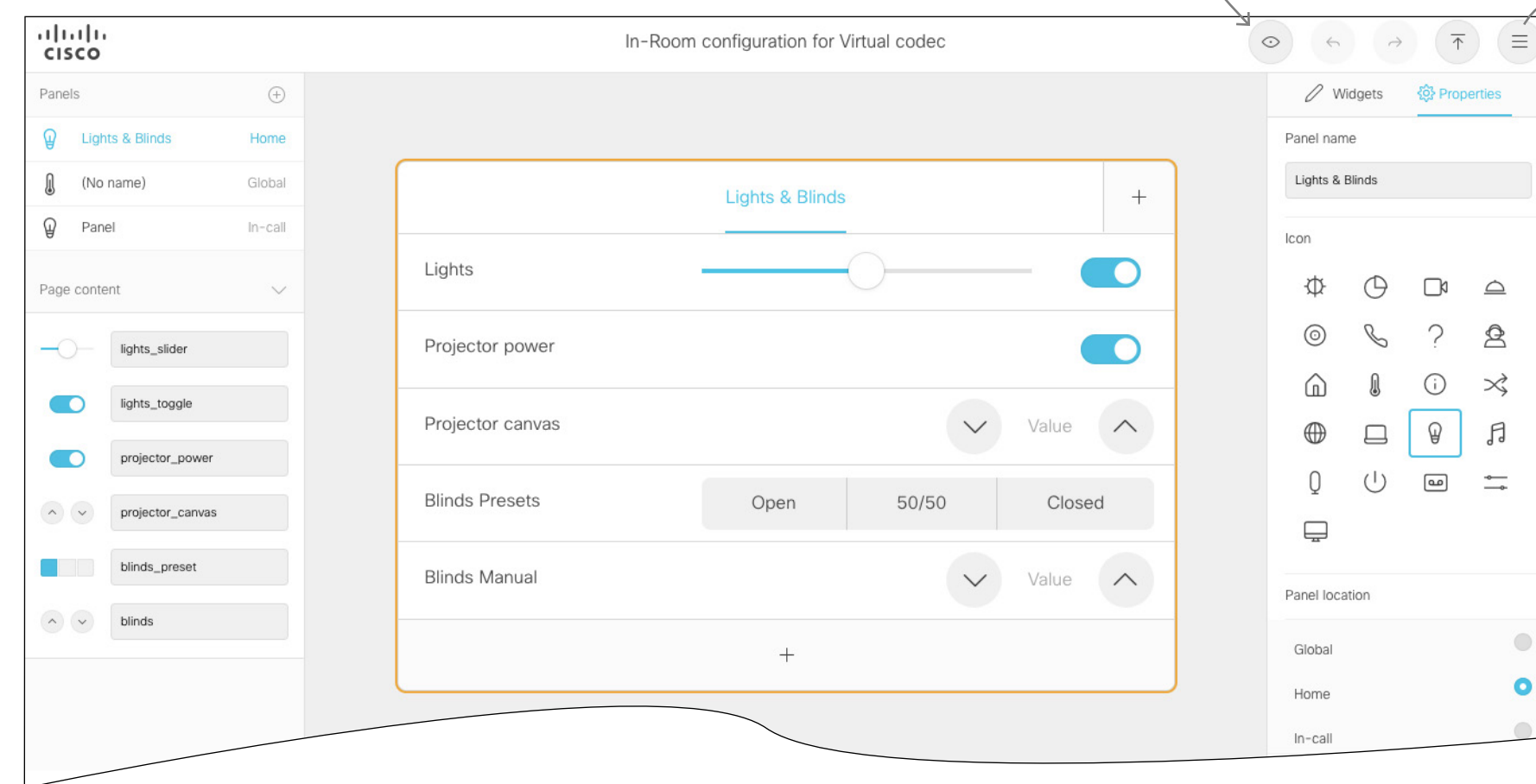

Click here to return to the previous view.

Click in the image to change to displaying the buttons that will appear on the Touch10.

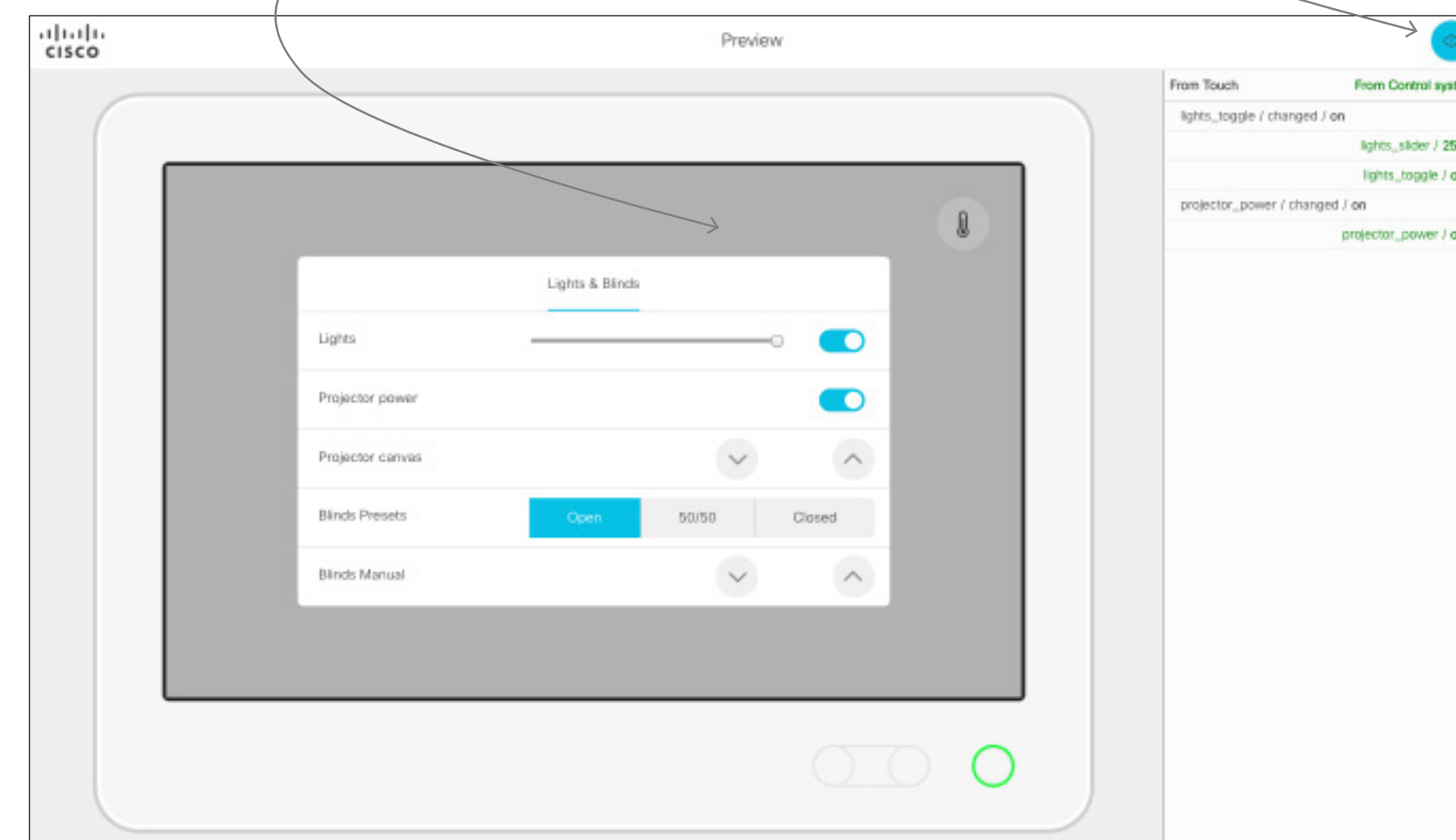

This pane shows the flow of information between a (simulated) control system and the Touch10.

Note! The simulator works for Touch10, DX and Webex Boards, but it will look it as if all of it has been created for a Touch10.

The above provides a simulated view of your configuration, with a simulated third-party control system connected.

When implementing your configurations (a real situation scenario), make sure your control system has been set to send SetValue commands wherever applicable.

Example: If you set **Lights** to **On** in a real situation scenario, the Touch10 needs to receive feedback confirming that the lights actually are switched on. For this to take place, the controller must switch on the lights and then send a SetValue, confirming the change of the lights settings. The right pane of the above example shows a simulation of what the Touch10 sends to the Control system and what the Control system then sends back to the Touch10.

In a real situation scenario, you should also make sure that the control system sends a SetValue to the Touch10 whenever someone operates the light switch on the wall in the meeting room.

Note! If you did not activate the Simulator before running this preview, the configuration will act as if no SetValue commands are received by the Touch10. When no such feedback is received, the **Lights** button on the Touch10 will return to its **Off** setting within a short while.

For more on this, see the following pages.

Application Programming Interface (API)

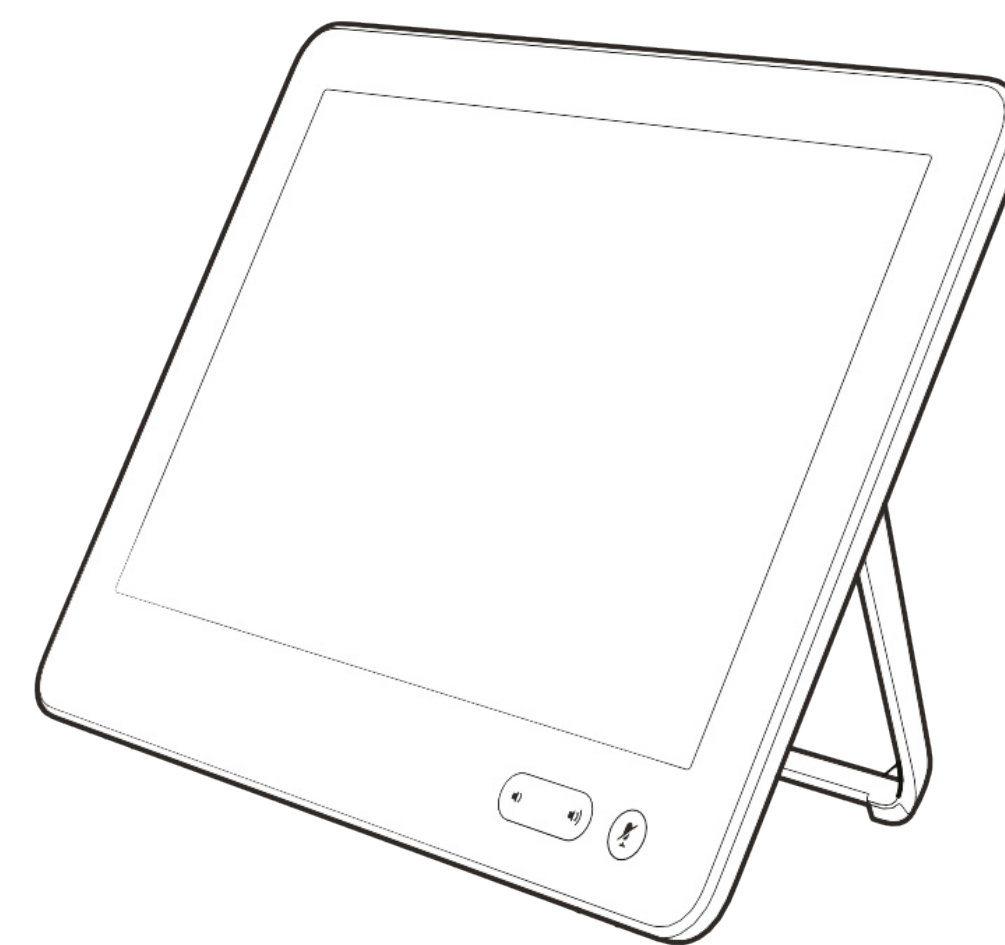

API for Programming In-Room Controls

Connect to the Video System

The video system's API (also known as the xAPI) allows bidirectional communication with third-party control systems, such as those from AMX or Crestron. There are multiple ways to access the xAPI:

- Telnet
- SSH
- HTTP/HTTPS
- RS-232 / serial connection

Regardless of the method you choose, the structure of the xAPI is the same. Choose the access method that suits your application and video system the best.

Consult the API guide for your video system to get a full description of available access methods and how to use the xAPI.

Go to:

- <http://www.cisco.com/go/sx-docs> for SX Series
- <http://www.cisco.com/go/mx-docs> for MX Series
- <http://www.cisco.com/go/dx-docs> for DX Series

Then, click **Reference Guides > Command References** to find the API guides.

Communicate over the API

The video system and the control system exchange messages through the xAPI to make sure that the Touch10/DX In-Room Control panel always reflects the actual status of the room.

The video system sends one or more events when someone uses one of the controls on the Touch10/DX In-Room Control panel, and the control system should send a command to the video system when there is a change in the room settings.

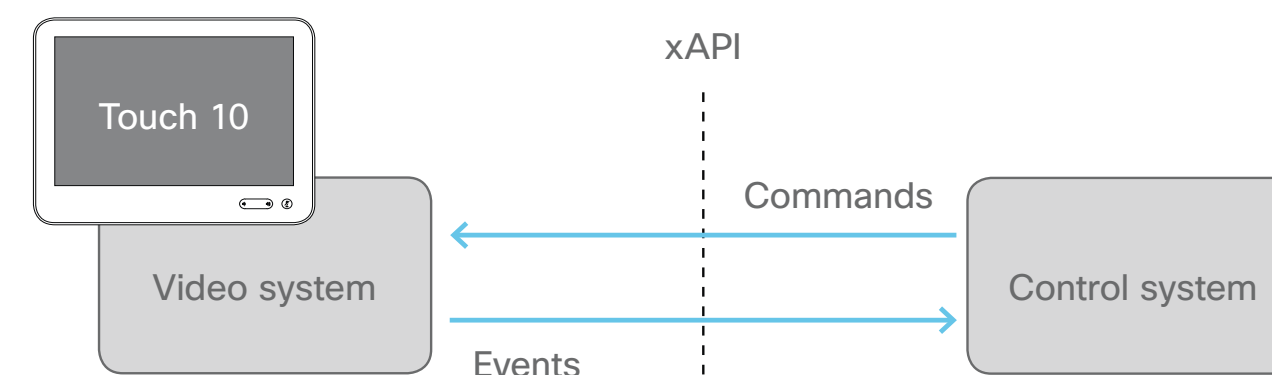

The video system and the control system exchange messages through the xAPI.

Examples:

- When someone taps a **Lights On** button on Touch10/DX, the video system sends the associated events. The control system should respond to these events by switching on the lights in the room and send the corresponding command back to the video system.
- When someone switches on the lights in the room, the control system should send a command to the video system, so that the video system can update the Touch10/DX In-Room Control panel to reflect that the light is on.

See the [Command reference chapter for an overview of all relevant events, commands and statuses for in-room control.](#)

Pairing Video System and Control System

You can register the control system as a peripheral connected to the video system:

```
xCommand Peripherals Connect ID: "ID" Type: ControlSystem
```

where ID is the unique ID for the control system, typically the MAC address.

See the API guide for more details about this command, and its options.

Heartbeats. The control system must send heartbeats to the video system to let the video system know that the control system is connected. The control system stays on the connected devices list (refer to xStatus Peripherals ConnectedDevice) as long as the video system receives these heartbeats from the control system.

```
xCommand Peripherals HeartBeat ID: "ID" [Timeout: Timeout]
```

where ID is the unique ID for the control system, typically the MAC address, and Timeout is the number of seconds between each heartbeat. If Timeout is unspecified, it is assumed to be 60 seconds.

Note! If a connected unit ceases to send heartbeats, some time will elapse until the video system detects the absence of heartbeats—as long as up to a couple of minutes.

This works the other way around as well, up to a couple of minutes may elapse until new heartbeats are detected by the codec.

API for Programming In-Room Controls (Cont.)

Events for Widget Actions

The video system sends one or more of the following events when someone uses the controls on the Touch10/DX in-room control panel:

- **Pressed**—sent when a widget is first pressed
- **Changed**—sent when changing a widget's value (applies to toggle buttons and sliders only)
- **Released**—sent when a widget is released (also when moving away from the widget before releasing)
- **Clicked**—sent when a widget is clicked (pressed and released without moving away from the widget).

These events are sent in two versions:

- **UserInterface Extensions Event**—suited for *terminal output mode*
- **UserInterface Extensions Widget**—suited for *XML output mode*.

See the table at right to find out the version best suited for your control system to register to.

When, and by which widgets (user interface elements), these events are triggered, are described in the [Widgets chapter](#).

UserInterface Extensions Event (suited for terminal output mode)	UserInterface Extensions Widget (suited for XML output mode)
<p>A single string contains information about the type of action, which widget triggered the event (identified by the Widget ID), and the widget value.</p>	<p>The type of action, which widget triggered the event (identified by the Widget ID), and the widget value are included as separate elements in the XML tree.</p>
<p>How to register:</p> <pre>xfeedback register event/UserInterface/Extensions/Event</pre> <p>Example:</p> <pre>*e UserInterface Extensions Event Pressed Signal: "<u>WidgetId:Value</u>" ** end *e UserInterface Extensions Event Changed Signal: "<u>WidgetId:Value</u>" ** end *e UserInterface Extensions Event Released Signal: "<u>WidgetId:Value</u>" ** end *e UserInterface Extensions Event Clicked Signal: "<u>WidgetId:Value</u>" ** end</pre>	<p>How to register:</p> <pre>xfeedback register event/UserInterface/Extensions/Widget</pre> <p>Example:</p> <pre><Event> <UserInterface item="1"> <Extensions item="1"> <Widget item="1"> <Action item="1"> <WidgetId item="1"><u>WidgetId</u></WidgetId> <Value item="1"><u>Value</u></Value> <Type item="1"><u>Type</u></Type> </Action> </Widget> </Extensions> </UserInterface> </Event></pre>

Two event versions that a control system can register to: one suited for terminal output mode, the other for XML output mode

API for Programming In-Room Controls (Cont.)

Event for Panel Update

The video system sends the following event when a new In-Room Control panel is applied:

LayoutUpdated—sent when a new in-room control panel for Touch10/10 is exported to the video system.

As a response to this event, the control system should send commands to initialize all widgets so that they reflect the true status of the room settings.

How to register:

```
xfeedback register event/UserInterface/Extensions/Widget/
  LayoutUpdated
```

Example:

Terminal output mode:

```
*e UserInterface Extensions Widget LayoutUpdated
** end
```

XML output mode:

```
<Event>
  <UserInterface item="1">
    <Extensions item="1">
      <Widget item="1">
        <LayoutUpdated item="1"/>
      </Widget>
    </Extensions>
  </UserInterface>
</Event>
```

Event for Opening or Closing of a Page

If you have given each of your pages a unique Page ID, the system can send events when a page is opened or closed.

EventPageOpened—sent when a page is opened

EventPageClosed—sent when a page is closed

The pages are like radio buttons, opening another page will close the current page. In that case both the EventPageClosed and the EventPageOpened will be issued.

How to register:

```
xfeedback register event/UserInterface/Extensions/PageOpened
xfeedback register event/UserInterface/Extensions/PageClosed
```

Example:

Terminal output mode:

```
*e UserInterface Extensions Event PageOpened PageId: "appletvpage"
*e UserInterface Extensions Event PageClosed PageId: "appletvpage"
```

XML output mode:

```
<Event>
  <UserInterface item="1">
    <Extensions item="1">
      <Page item="1">
        <Action item="1">
          <PageId item="1">appletvpage</PageId>
          <Type item="1">Opened</Type>
        </Action>
      </Page>
    </Extensions>
  </UserInterface>
</Event>
```

For an example of PageClosed, just substitute Closed for Opened in the example at left. This event will typically be used when you want the controller to take some action based on the event, in this case turning on (off) the AppleTV box for you.

API for Programming In-Room Controls (Cont.)

Commands and Statuses

The SetValue command, which sets the value of a widget, is essential when working with in-room controls:

```
xCommand UserInterface Extensions Widget SetValue
  Value: Value WidgetId: WidgetId
```

When the video system receives a SetValue command, the video system's status and the Touch10/DX/Webex Board In-Room Control panel are updated accordingly.

It is important that the control system sends SetValue commands in the following situations, so that the In-Room Control panel truly reflects the status of the room:

- When the control system initially connects to the video system.
- When the video system restarts.
- When the control system restarts.
- When a new In-Room Control panel is exported to the video system from the In-Room Control editor (as response to the LayoutUpdated event).
- When someone physically changes something in the room, for example turns on the lights using a wall control.
- As a response to an event, for example when someone has tapped the **Lights On** button on the In-Room Control panel.
- The control system must also do all that is necessary in the room to reflect the action on the In-Room Control panel, for example actually switch on the light.

Consult the [Widgets chapter for more details about which commands apply to the different widgets \(user interface elements\)](#).

Examples

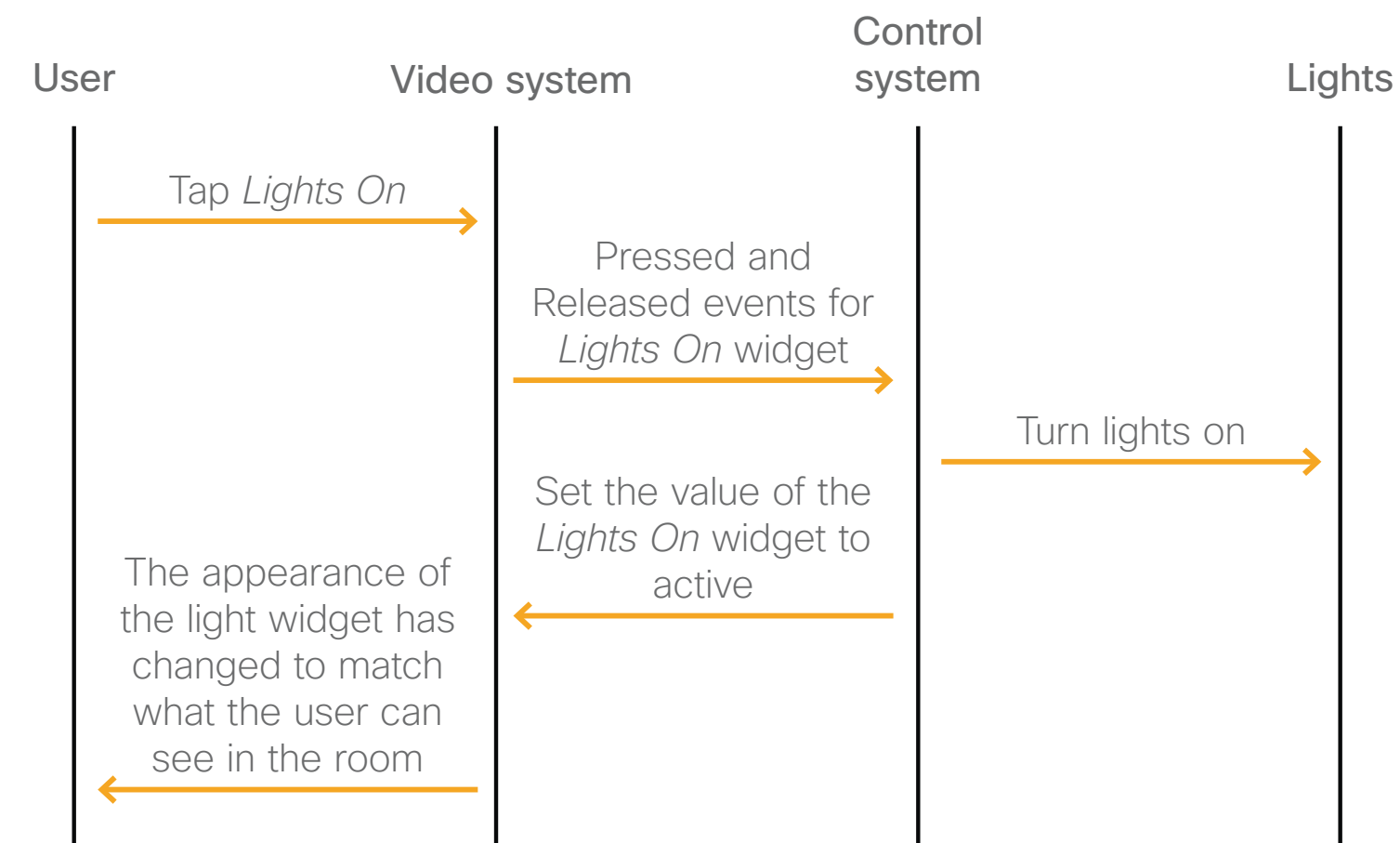

Message flow—turn on the lights using the controls on Touch10/DX/Webex Board

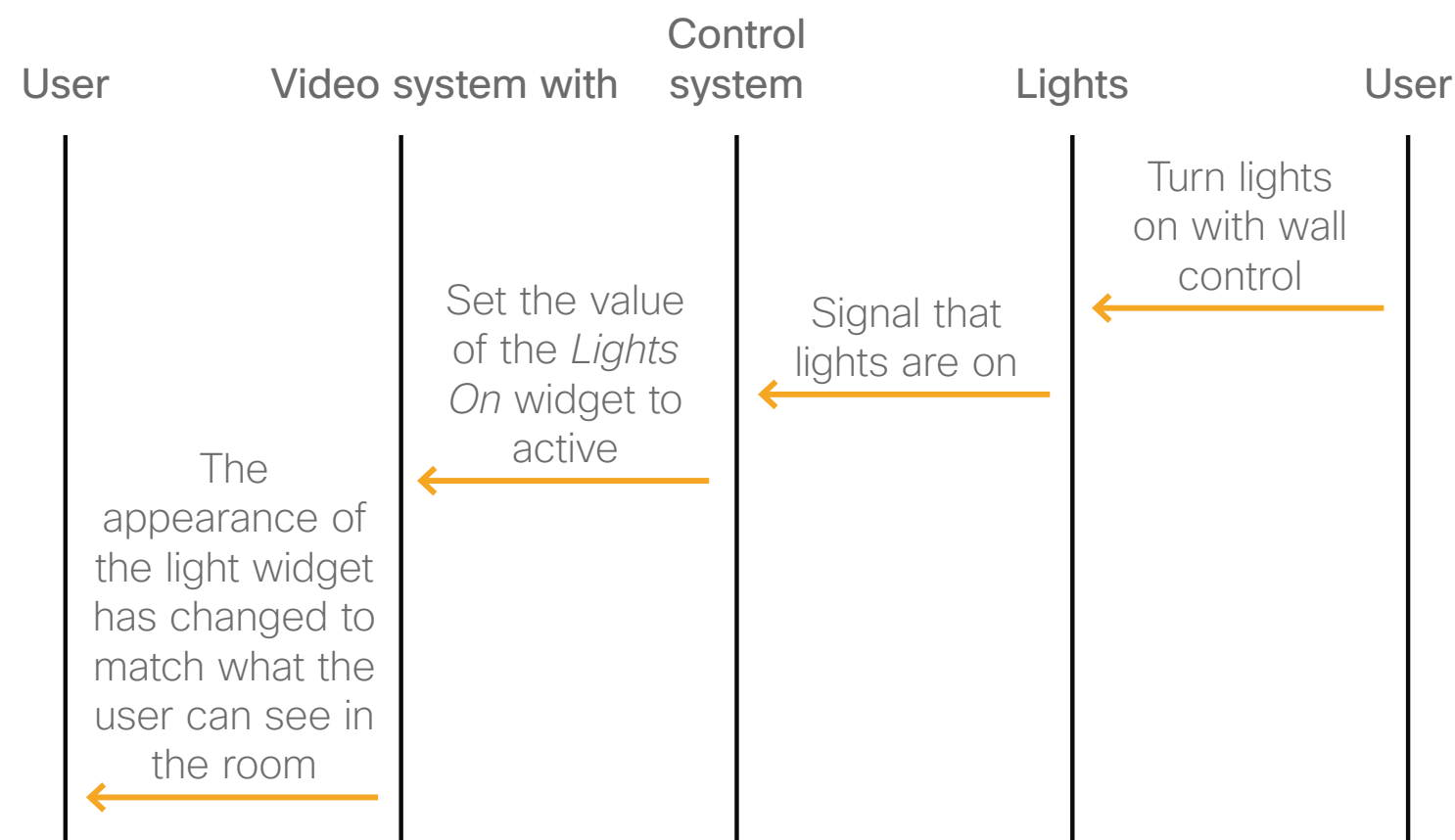

Message flow—turn on the lights using the wall control

Widgets

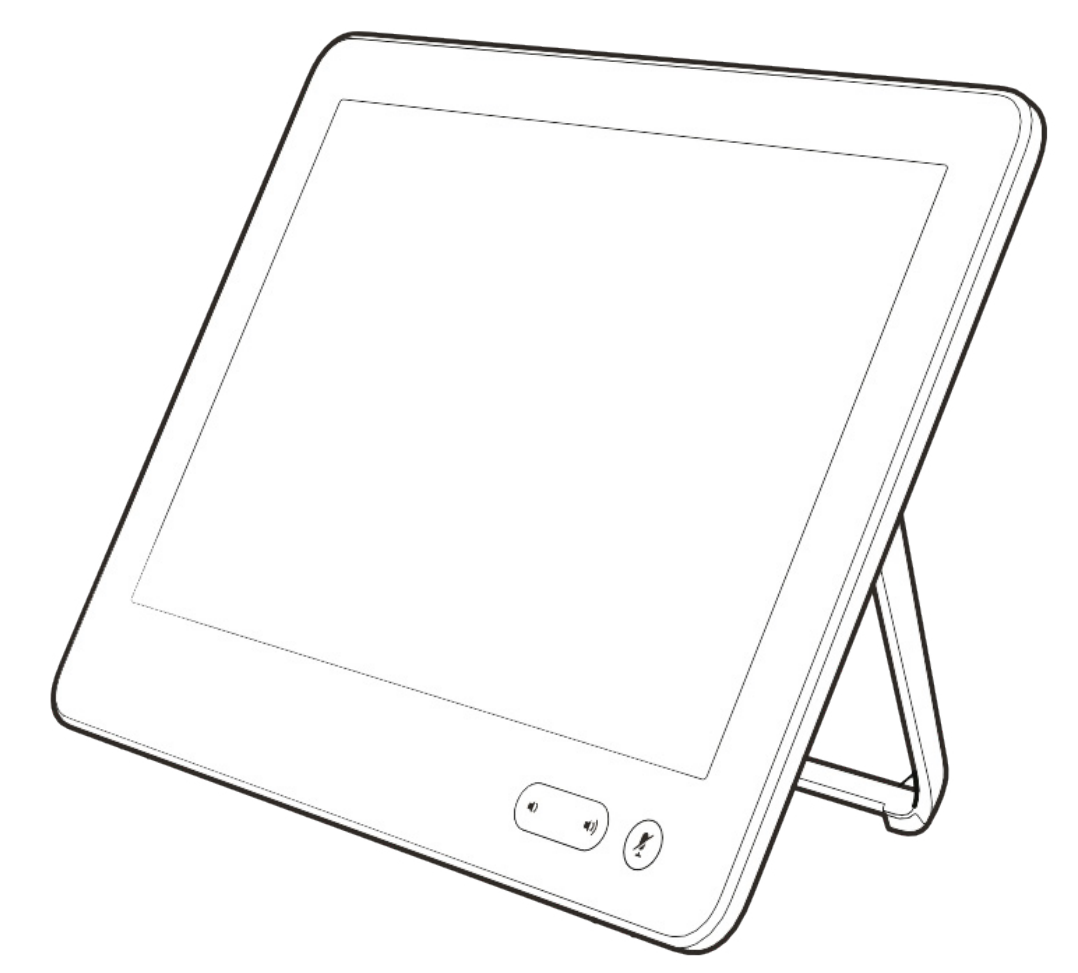

Overview of Widgets

About Widgets

The In-Room Control panel is composed of user interface elements called widgets. You can find the complete widget library in the right pane of the In-Room Control editor.

General tab: Buttons with custom text, group buttons, toggle button, sliders, text fields and more.

Icons tab: Buttons with familiar symbols for Home, Power, Arrow up/down/left/right, Camera controls, Loudspeaker controls, Microphone control, Media player controls, and more.

Each of the widget types available are described on the following pages, with emphasis on:

- Commands that change the value of the widget
- Events that are sent (pressed, changed, released, clicked) and which actions trigger these events
- Examples of commands and events, both in terminal output mode and XML output mode.

Syntax and semantics for all events, commands and statuses that are related to in-room controls (user interface extensions) are included in the Command reference chapter.

The Widget Identifier

All widgets on a In-Room Control panel need a unique identifier, a Widget ID. The Widget ID may either be defined by you, or assigned automatically. The Widget ID can be any name or number; we recommend using a descriptive name without special characters. The maximum number of characters is 255.

The Widget ID is the programming link between Touch10/DX/Webex Board, the video system, and the control system. The Widget ID will be included in all events that are associated with a widget, and you must use the same identifier when you send commands to that widget via the code that you write for your control system.

Group Identifiers

One of the widgets, the Group button, has two types of identifiers: The Widget ID refers to the complete group of buttons, while Group IDs are unique identifiers for the individual buttons within the group.

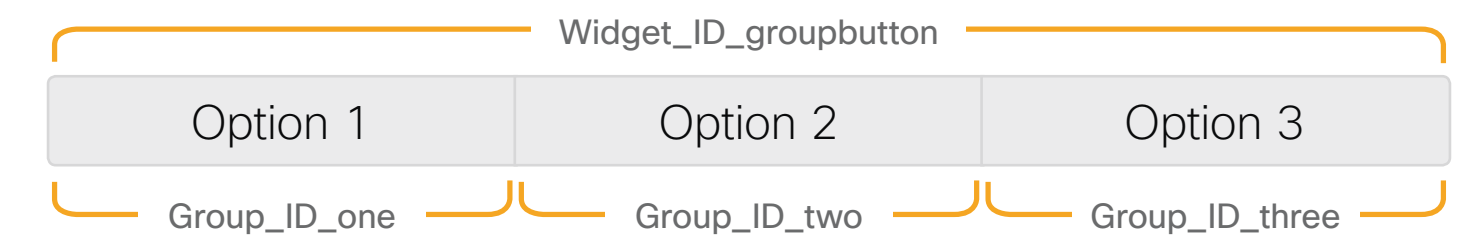

A Group ID is assigned automatically, but can be defined by you instead. A Group ID can be any name or number; we recommend using a descriptive name without special characters. The maximum number of characters is 255.

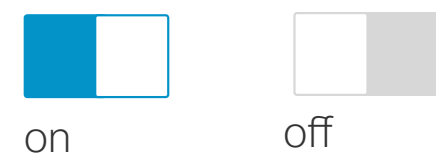
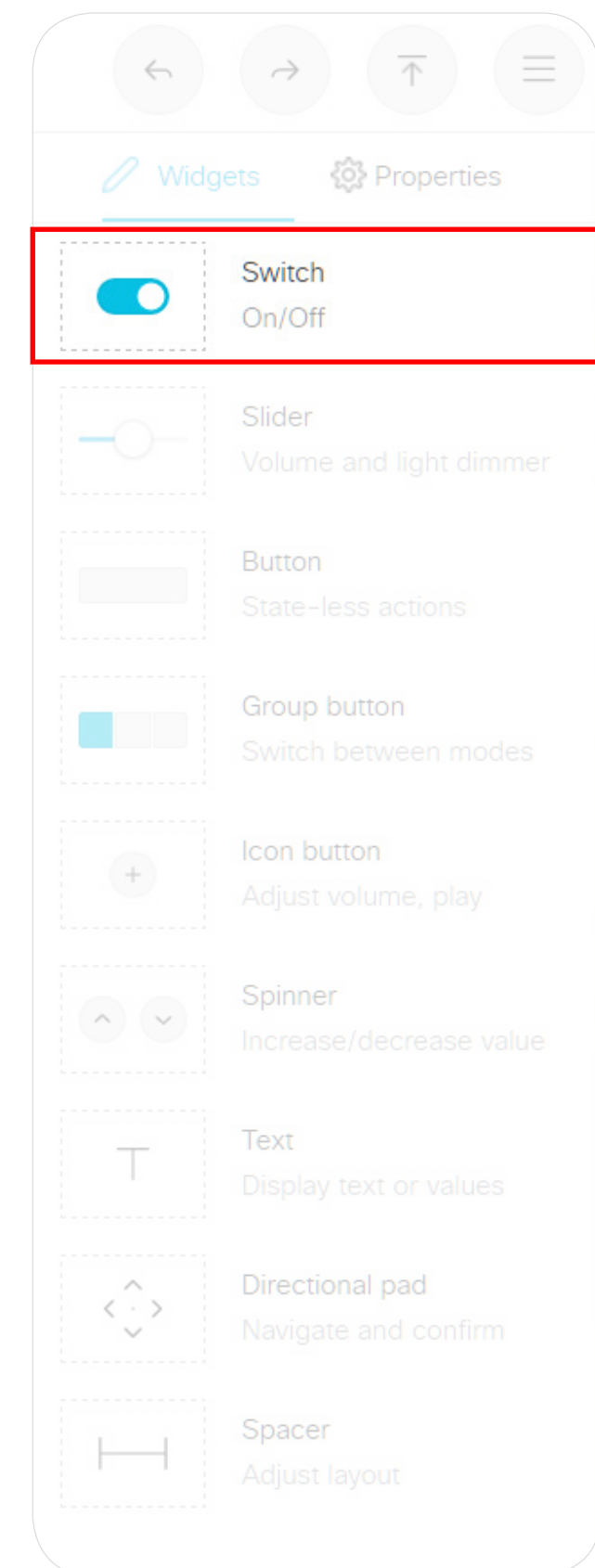

on

off

A two-state switch which indicates either on or off.

Events

Changed—triggered when the button is released.

Value: <on/off>

Commands

The visual appearance of the button changes immediately when you tap it. However, the control system must always send a SetValue command to the video system when the button toggles between *on* and *off*. This ensures that the status is updated accordingly.

Example: Press "on" on a switch with WidgetId = "togglebutton".

Terminal mode

```
*e UserInterface Extensions Event Changed Signal: "togglebutton:on"
** end
```

XML mode

```
<Event>
  <UserInterface item="1">
    <Extensions item="1">
      <Widget item="1">
        <Action item="1">
          <WidgetId item="1">togglebutton</WidgetId>
          <Value item="1">on</Value>
          <Type item="1">changed</Type>
        </Action>
      </Widget>
    </Extensions>
  </UserInterface>
</Event>
```

Example: Set a button with WidgetId = "togglebutton" to "on".

```
xCommand UserInterface Extensions Widget SetValue WidgetId: "togglebutton" Value: "on"
```

Switch is a two-state button which indicates either on or off.

Example of use: Anything that can be turned on or off, for example lights, fan, and projector.

You can also use it as a toggle button together with a slider for lights to be dimmed.

Events

Pressed	Triggered when the slider is pressed Value: N/A
Changed	Triggered when the slider is moved while holding down, and when the slider is released. Value: 0-255
Released	Triggered when the slider is released Value: 0-255

Example: Press the slider with WidgetId = "slider", and move it into a new position ("68"), and release.

Terminal mode

```
*e UserInterface Extensions Event Pressed Signal: "slider"
** end
*e UserInterface Extensions Event Changed Signal: "slider:32"
** end
*e UserInterface Extensions Event Changed Signal: "slider:68"
** end
*e UserInterface Extensions Event Released Signal: "slider:68"
** end
```

XML mode

```
<Event>
  <UserInterface item="1">
    <Extensions item="1">
      <Widget item="1">
        <Action item="1">
          <WidgetId item="1">slider</WidgetId>
          <Value item="1">68</Value>
          <Type item="1">released</Type>
        </Action>
      </Widget>
    </Extensions>
  </UserInterface>
</Event>
```

A slider selects values within a set range. The minimum value is represented by 0, and the maximum value is represented by 255. When the slider is being pressed and moved, events are sent maximum 5 times a second.

When you tap the bar, the slider is immediately moved to that new position.

Example of use: Dimmable lights, volume control.

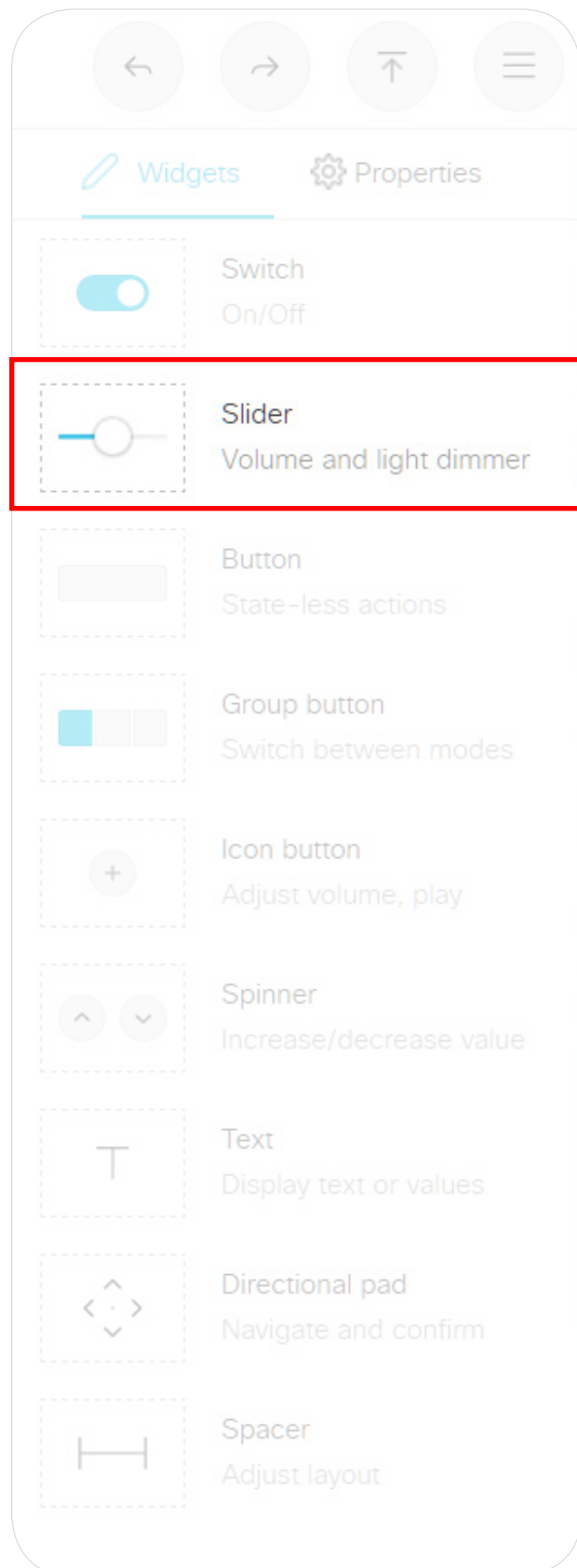

Commands

The visual appearance of the slider changes immediately when you tap or slide it. However, the control system must always send a SetValue command to the video system to tell the new position of the slider. This ensures that the status is updated accordingly.

Example: Set the slider with WidgetId = "slider" to position "98".

```
xCommand UserInterface Extensions Widget SetValue WidgetId: "slider" Value: "98"
```

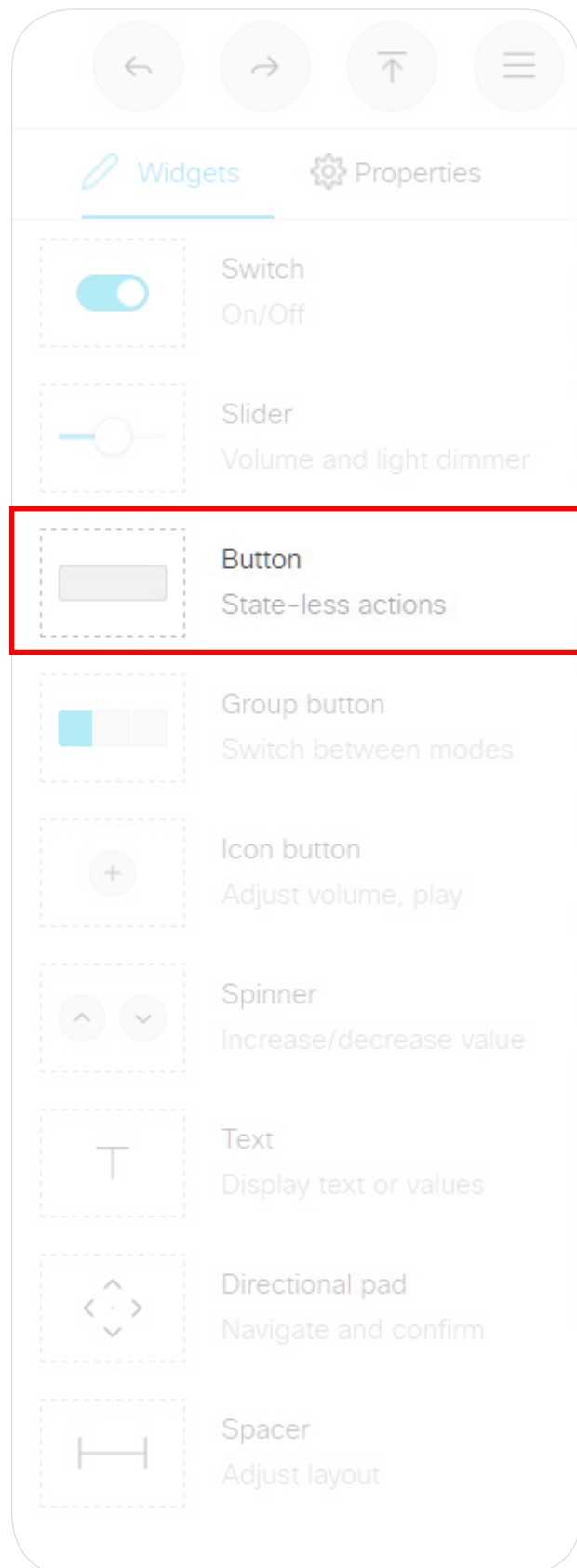

Events

Pressed	Triggered when the button is pressed. Value: N/A
Changed	Triggered when the button is released. Value: N/A
Released	Triggered when the button is released. Value: N/A

Example: Press and release the button with WidgetId = "button".

Terminal mode

```
*e UserInterface Extensions Event Pressed Signal: "button"
** end
*e UserInterface Extensions Event Released Signal: "button"
** end
*e UserInterface Extensions Event Clicked Signal: "button"
** end
```

XML mode

```
Event>
<UserInterface item="1">
  <Extensions item="1">
    <Widget item="1">
      <Action item="1">
        <WidgetId item="1">button</WidgetId>
        <Value item="1"></Value>
        <Type item="1">clicked</Type>
      </Action>
    </Widget>
  </Extensions>
</UserInterface>
</Event>
```

Buttons with custom text come in different sizes. The size determines the maximum number of characters you can add. Text does not wrap to a new line. You cannot use the SetValue command to change the text dynamically.

A button has two states: active and inactive. You do not have to set the button in active state when someone taps it; the button can be used to just send a signal without changing the button's visual state.

If you want to have the buttons linked so that only one can be selected at a time (radio buttons), consider to use Group buttons (next page).

Example of use: Switching things on and off.

Commands

Use the SetValue command to highlight or not the button in the user interface. A value of "active" will highlight the button, and a value of "inactive" will release it.

Example: Highlight the button with WidgetId = "button" (set it in active state).

```
xCommand UserInterface Extensions Widget SetValue WidgetId: "button" Value: "active"
```

Group Button

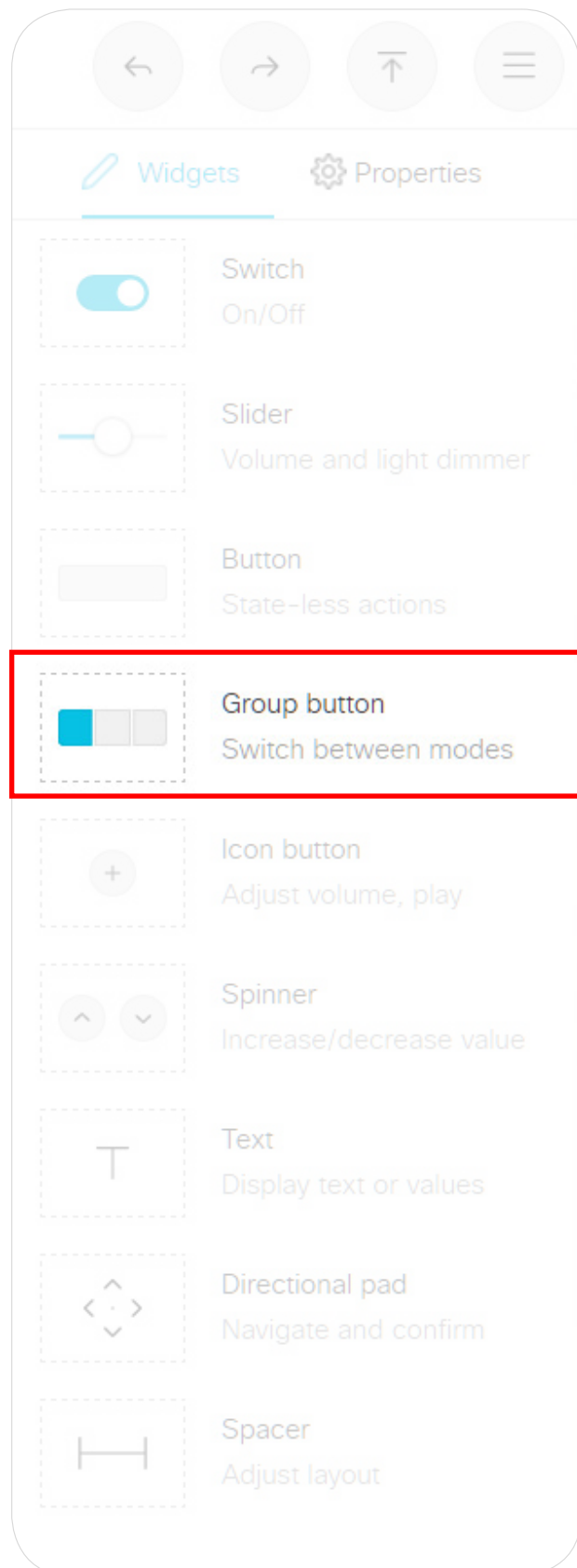

Events

- Pressed** Triggered when one of the buttons is pressed.
Value: The Group ID of the button (within the group) that was pressed.
- Released** Triggered when one of the buttons is released.
Value: The Group ID of the button (within the group) that was released

Example: There are four buttons in the group with WidgetId = "groupbutton". Press the button with Group ID = "two".

```

..... Terminal mode .....
*e UserInterface Extensions Event Pressed Signal: "groupbutton:two"
** end
*e UserInterface Extensions Event Released Signal: "groupbutton:two"
** end
..... XML mode .....
<Event>
  <UserInterface item="1">
    <Extensions item="1">
      <Widget item="1">
        <Action item="1">
          <WidgetId item="1">groupbutton</WidgetId>
          <Value item="1">two</Value>
          <Type item="1">released</Type>
        </Action>
      </Widget>
    </Extensions>
  </UserInterface>
</Event>

```

Group buttons may now be made as a matrix and not just as a line. This means that you are no longer confined to a maximum of 4 radio buttons.

A matrix consists of up to 4 columns and as many rows as you need.

You start by defining how many columns your matrix should consist of (1, 2, 3 or 4). This is a global setting applying to the entire matrix (i.e. all the rows) and it defines the maximum number of buttons per row.

However, a row may contain fewer buttons than this maximum number. Button autosizing will then take place—the buttons will always fill the space available.

Example: Assume that you have defined the matrix to consist of 3 columns and you need 7 buttons (i.e. 3 rows). The system will then put 3 in the first row and 3 in the second row, and the last button in the third row. The single button in the third row will be autosized to fill the space (spanning all 3 columns).

The size of a button determines the maximum number of characters you can add. Text does not wrap to a new line, but will be truncated, whenever needed.

You cannot use the SetValue command to change the text dynamically.

Example of use: Room presets that are mutually excluding, like room presets where you can choose between Dark, Cool, and Bright. Remember to deselect (release) the preset, if it is no longer valid (for instance when changing the lights with a wall control, or a In-Room Control slider).

Another example of use: Changing to a different UI language.

Commands

The visual appearance of the button changes immediately when you tap it. However, the control system must always send a SetValue command to the video system when one of the buttons are tapped. This ensures that the status is updated accordingly.

Use the UnSetValue command to release all buttons in the group so that no button is highlighted.

Example: Select (highlight) the button with Group ID = "one" in the group with WidgetId = "groupbutton". Then, release all buttons (no buttons are highlighted).

```
xCommand UserInterface Extensions Widget SetValue
WidgetId: "groupbutton" Value: "one"
```

```
xCommand UserInterface Extensions Widget UnsetValue
WidgetId: "groupbutton"
```

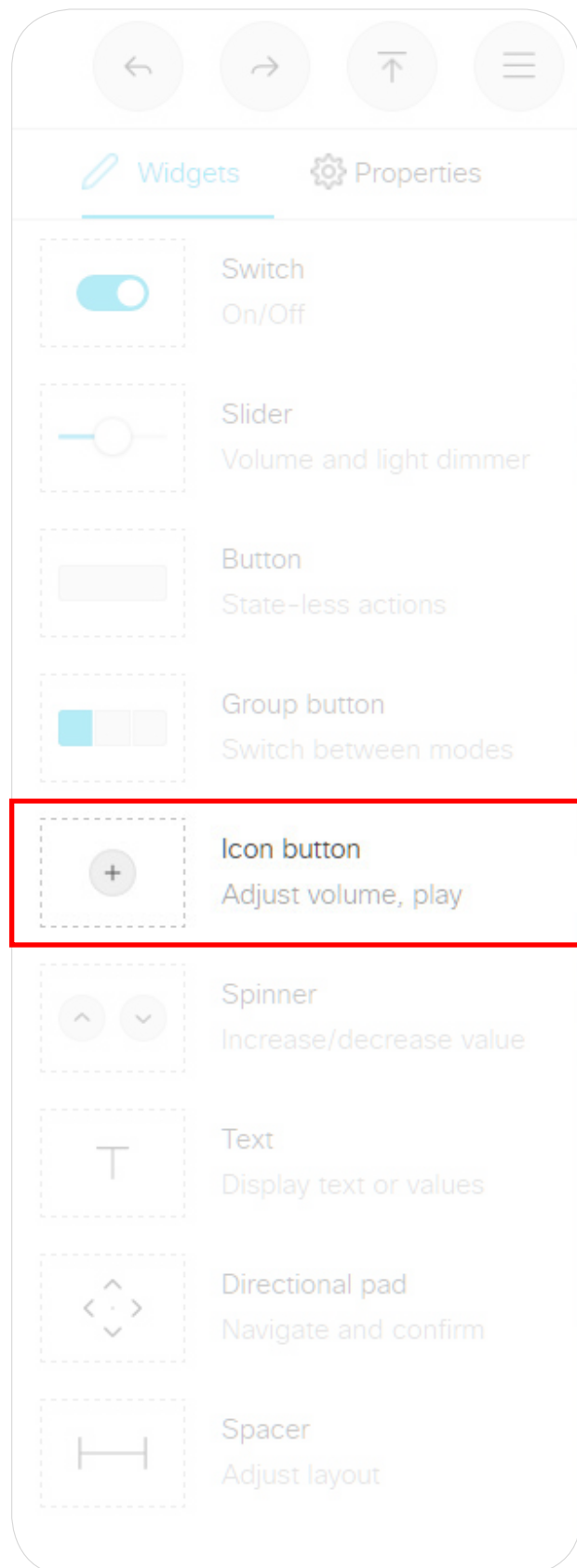

Events

Pressed	Triggered when the button is pressed. Value: N/A
Released	Triggered when the button is released. Value: N/A
Clicked	Triggered when the button is released. Value: N/A

Example: Press and release the button with WidgetId = "symbol".

Terminal mode

```
*e UserInterface Extensions Event Pressed Signal: "symbol"
** end
*e UserInterface Extensions Event Released Signal: "symbol"
** end
*e UserInterface Extensions Event Clicked Signal: "symbol"
** end
```

XML mode

```
<Event>
  <UserInterface item="1">
    <Extensions item="1">
      <Widget item="1">
        <Action item="1">
          <WidgetId item="1">symbol</WidgetId>
          <Value item="1"></Value>
          <Type item="1">clicked</Type>
        </Action>
      </Widget>
    </Extensions>
  </UserInterface>
</Event>
```

Icon buttons share behavior with buttons having custom text.

A button has two states: active and inactive. You do not have to set the button in active state when someone taps it; the button can be used to just send a signal without changing its visual state.

Example of use: Controls for a media player, or other devices that can start, stop, pause.

Commands

Use the SetValue command to highlight or not the button in the user interface. A value of "active" will highlight the button, and a value of "inactive" will release it.

Example: Highlight the button with WidgetId = "symbol" (set it in active state)

```
xCommand UserInterface Extensions Widget SetValue WidgetId: "symbol"
Value: "active"
```

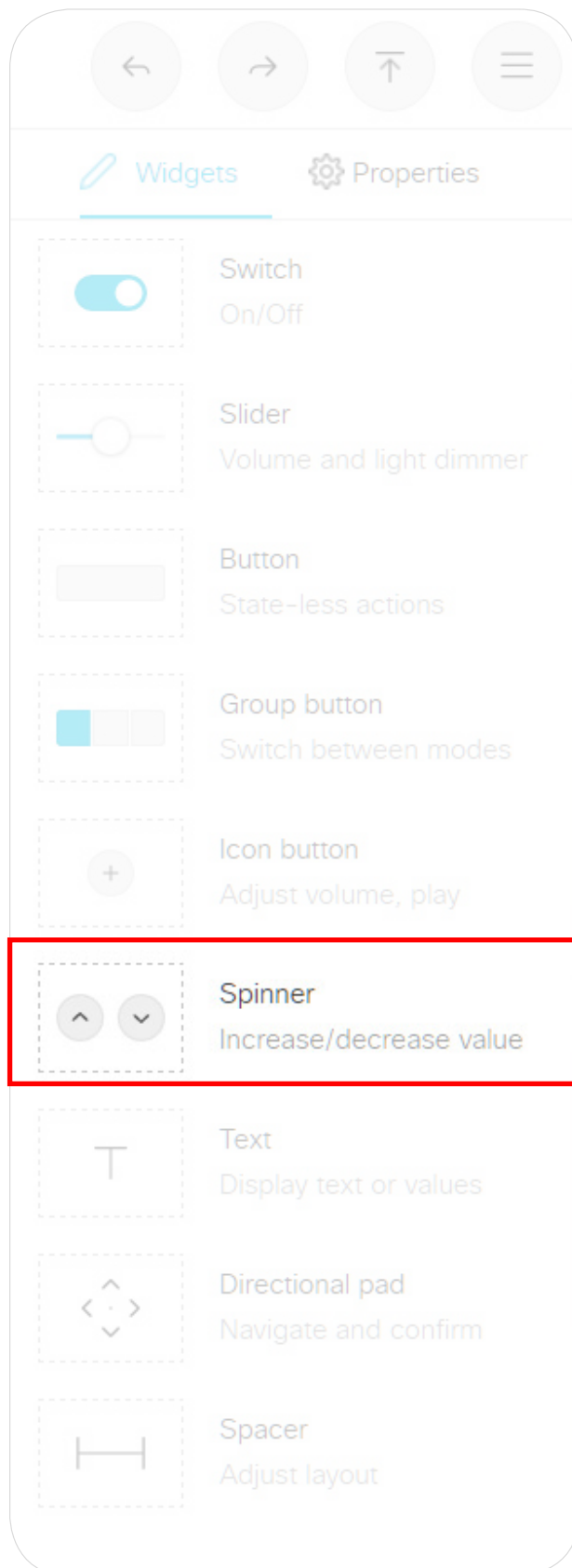

Events

- Pressed** Triggered when one of the spinner buttons is pressed. **Value:** <increment/decrement>
- Released** Triggered when one of the spinner buttons is released. **Value:** <increment/decrement>
- Clicked** Triggered when one of the spinner buttons is released. **Value:** <increment/decrement>

Example: Press and release the decrement button of the spinner with WidgetId = "spinner".

Terminal mode

```
*e UserInterface Extensions Event Pressed Signal: "spinner:decrement"
** end
*e UserInterface Extensions Event Released Signal: "spinner:decrement"
** end
*e UserInterface Extensions Event Clicked Signal: "spinner:decrement"
** end
```

XML mode

```
<Event>
  <UserInterface item="1">
    <Extensions item="1">
      <Widget item="1">
        <Action item="1">
          <WidgetId item="1">spinner</WidgetId>
          <Value item="1">decrement</Value>
          <Type item="1">clicked</Type>
        </Action>
      </Widget>
    </Extensions>
  </UserInterface>
</Event>
```

A spinner is used to step through a list of values. You may use the two buttons to increment or decrement a number, or to step through a list of options.

Use the SetValue command to add text between the buttons.

Example of use: Set the desired temperature in the room.

Commands

Use the SetValue command to add or update the text between the two buttons.

Example: For the spinner with WidgetId = "spinner", add the text "22" between the spinner's increment and decrement buttons.

```
xCommand UserInterface Extensions Widget SetValue WidgetId: "spinner"
Value: "22"
```

Events

None

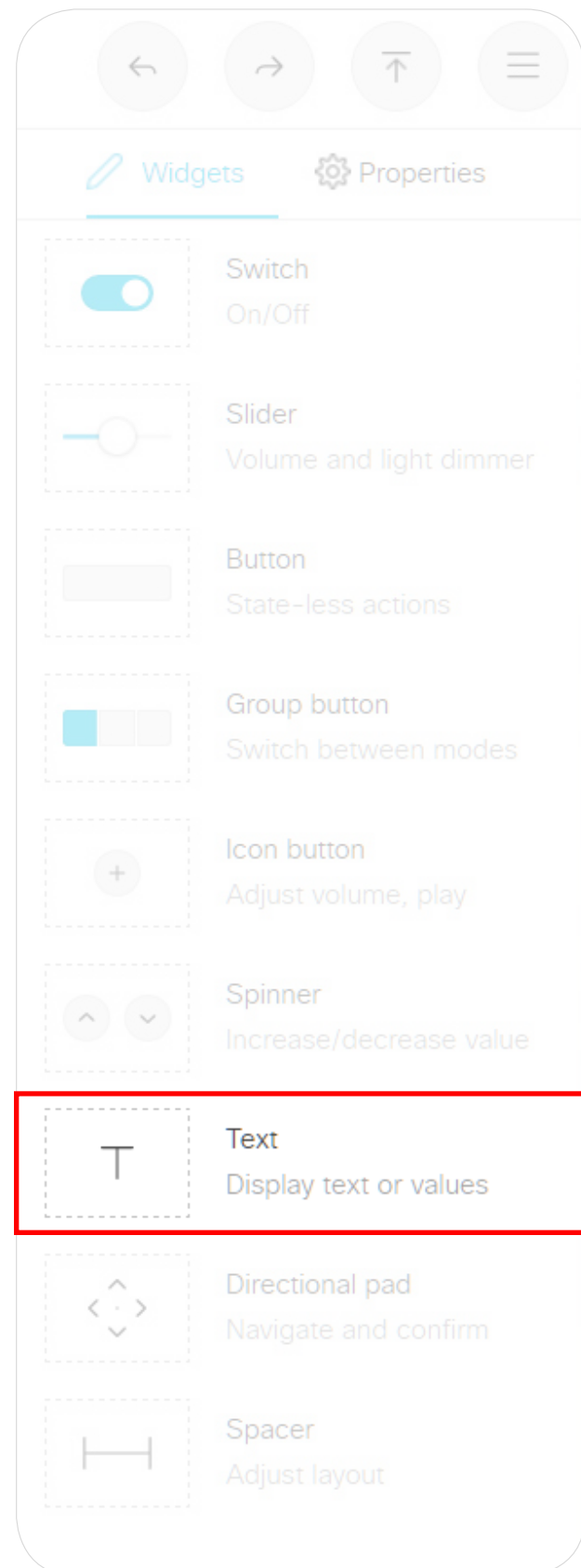

Commands

Use the `SetValue` command to set the text in the text box.

Example: Set the following text in the text box with `WidgetId = "textbox"`: "The projector is warming up."

```
xCommand UserInterface Extensions Widget SetValue WidgetId: "textbox"
Value: "The projector is warming up."
```

Text boxes come in different sizes. They have up to two lines of text and the text automatically wraps to the new line.

A small text box with larger font size and no line wrap is also available.

You can define the initial text for the text box in the editor, and later on use the `SetValue` command to enter text dynamically.

Example of use: Help text, instructions, explanation of what different presets mean, or informative text from the control system, such as "The projector is warming up."

The text box with larger font size is primarily meant for status values, such as the current temperature in the room.

Directional Pad

Events

Pressed	Triggered when the button is pressed. Value: N/A
Changed	Triggered when the button is released. Value: N/A
Released	Triggered when the button is released. Value: N/A

Example: Press and release the button with WidgetId = "dirpad".

Terminal mode

```
*e UserInterface Extensions Event Pressed Signal: "dirpad:up"
** end
*e UserInterface Extensions Event Released Signal: "dirpad:up"
** end
*e UserInterface Extensions Event Clicked Signal: "dirpad:up"
** end
```

XML mode

```
<Event>
  <UserInterface item="1">
    <Extensions item="1">
      <Widget item="1">
        <Action item="1">
          <WidgetId item="1">dirpad</WidgetId>
          <Value item="up"></Value>
          <Type item="1">clicked</Type>
        </Action>
      </Widget>
    </Extensions>
  </UserInterface>
</Event>
```

The Directional Pad can be regarded as a set of 5 buttons, the four Directional buttons and the Center button.

As can be seen from the examples at left, the event will be of the form:

"<WidgetId>:<*the button pushed*>"

in which *the button pushed* assumes the value:

up, down, left, right or center

Example of use: Controlling AppleTV

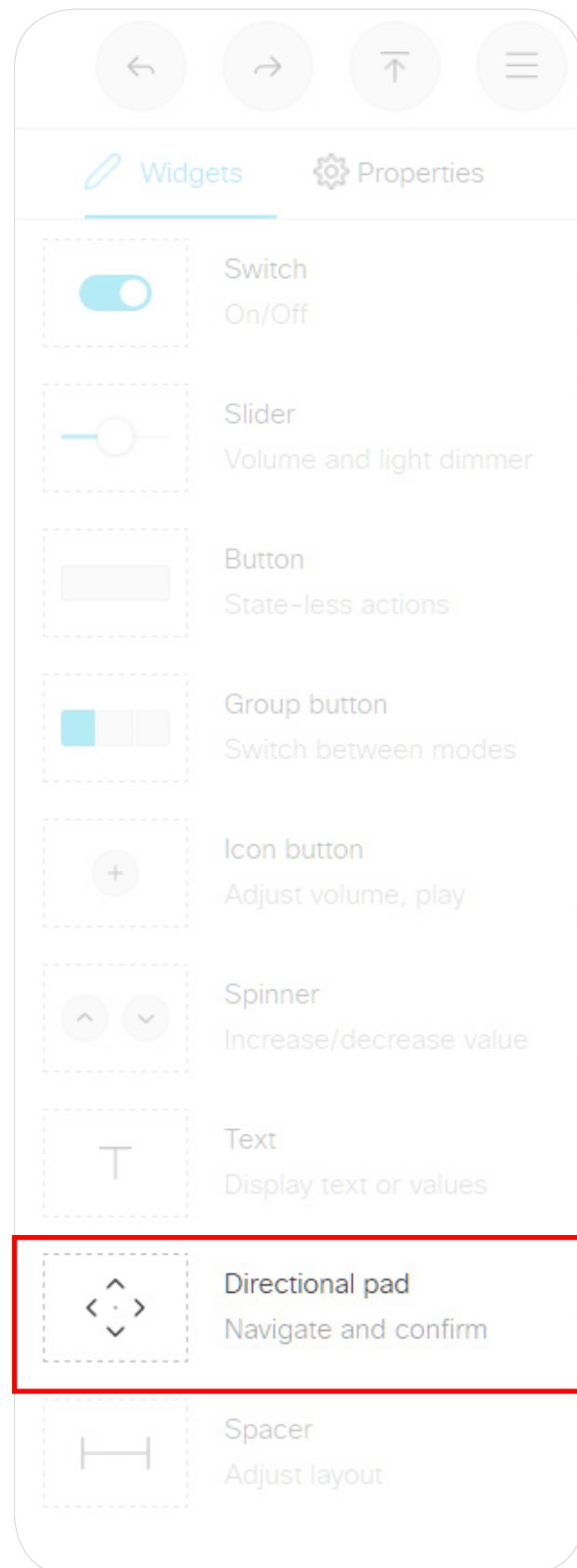

Spacer

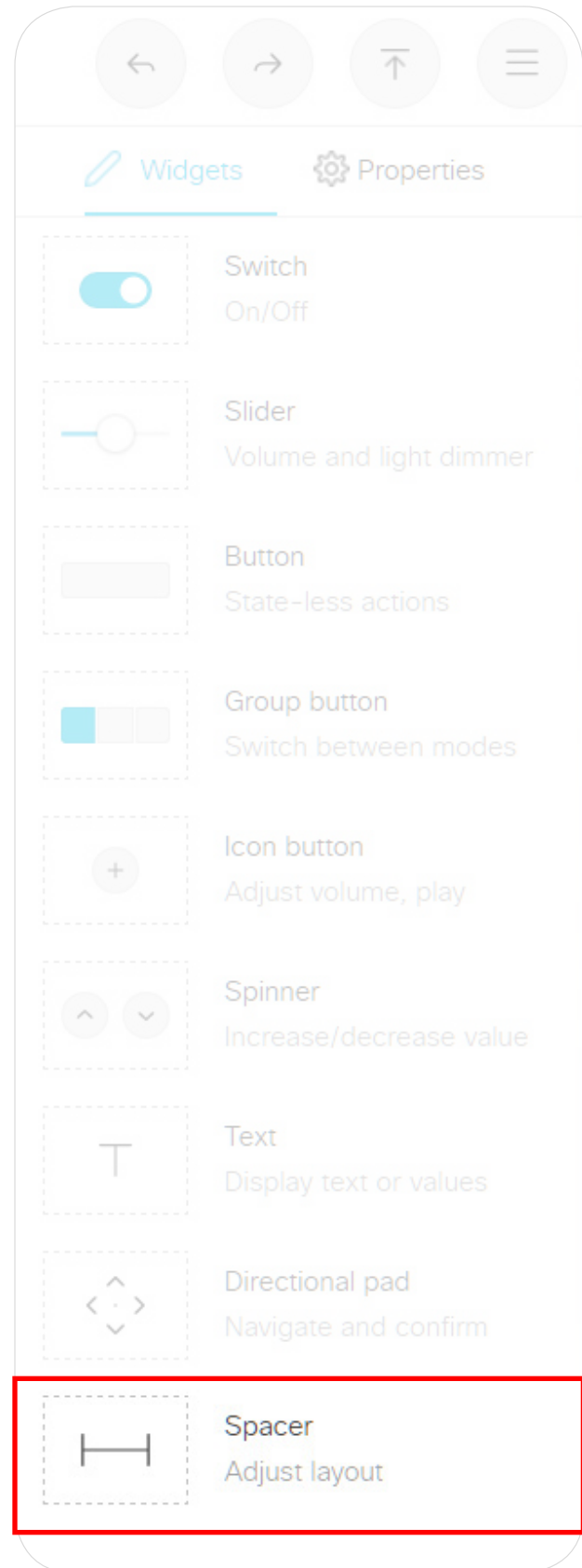

The Spacer is no more than a layout tool. Consequently, there are no events or commands associated with it.

The Spacer lets you add space between or after widgets. It is no more than a layout tool.

The width of the spacer is adjustable (1-4). If you set it to maximum it will occupy its own line, making it usable as a vertical spacer, as well.

Removing Default Buttons



Removing Default Buttons

Why Remove Buttons?

What Is It?

This feature adds the ability to hide default feature buttons in UI while still exposing custom In-Room Control panels. This allows for a more customizable UI.

Even here you will need local admin access to the device to use the xConfigurations.

More specifically, what this feature does is to add a series of configurations that allow you to hide/display certain feature buttons in the UI that has previously not been possible to hide. The feature was new in CE9.6 and has been expanded to include **Turn video On/Off** button.

Functional Overview

The following is at your disposal:

```
xconfig //userinterface/features ?
```

```
*? xConfiguration UserInterface Features Call End: <Auto, Hidden>
```

```
*? xConfiguration UserInterface Features Call MidCallControls: <Auto, Hidden>
```

```
*? xConfiguration UserInterface Features Call Start: <Auto, Hidden>
```

```
*? xConfiguration UserInterface Features Call VideoMute: <Auto, Hidden> NEW
```

```
*? xConfiguration UserInterface Features HideAll: <False, True>
```

```
*? xConfiguration UserInterface Features Share Start: <Auto, Hidden>
```

```
OK
```

The above configurations will also be available via the web interface of the Room Device. The default configurations are indicated in **bold**.

If you choose hide the **Call** (Start) button, this will also hide the default UI feature for making a call or do directory lookups / favorites / recent calls etc. In addition, the **Add** button which is used to add participants while in a call will be hidden.

The MidCallControls are **Hold**, **Transfer** and **Resume**.

Hiding the **Share** button will hide the default UI for sharing as well as hiding the ability to preview sources in- and out-of-call.

Limitations

The feature applies to the Call, MidCallControls and Share sets of buttons only.

You cannot hide other single buttons whose display is a result of certain use-cases, such as Meetings, Extension Mobility, Voicemail etc. These buttons must either be all displayed or all hidden.

If you choose to hide them all, only your custom-made buttons will be shown. To do this, use:

```
xConfiguration UserInterface Features HideAll: <False, True>
```

You may circumvent this all-or-nothing problem through selective provisioning of the settings from the back-end.

Note! This feature is about removing buttons only. The functions themselves are not removed. For instance, although the **Share** button may be removed, the function will still be accessible via Proximity.

Example of Use

Examples of how this can be implemented are shown on the following pages.

Sometimes you may want to create a completely customized UI for your users.

So far, this has not been possible as the **Call** button and **Share** button have always remained visible together with your Custom buttons.

This may cause confusion among users in scenarios where the **Call** or **Share** buttons have no meaning.

Scenario

Assume that we want to create a scenario where users are limited to call a few specific rooms only. This could be the case in companies where external calls are never made. All calls are assumed to take place between this limited number of rooms.

Doing It

Starting out with a standard UI like this:

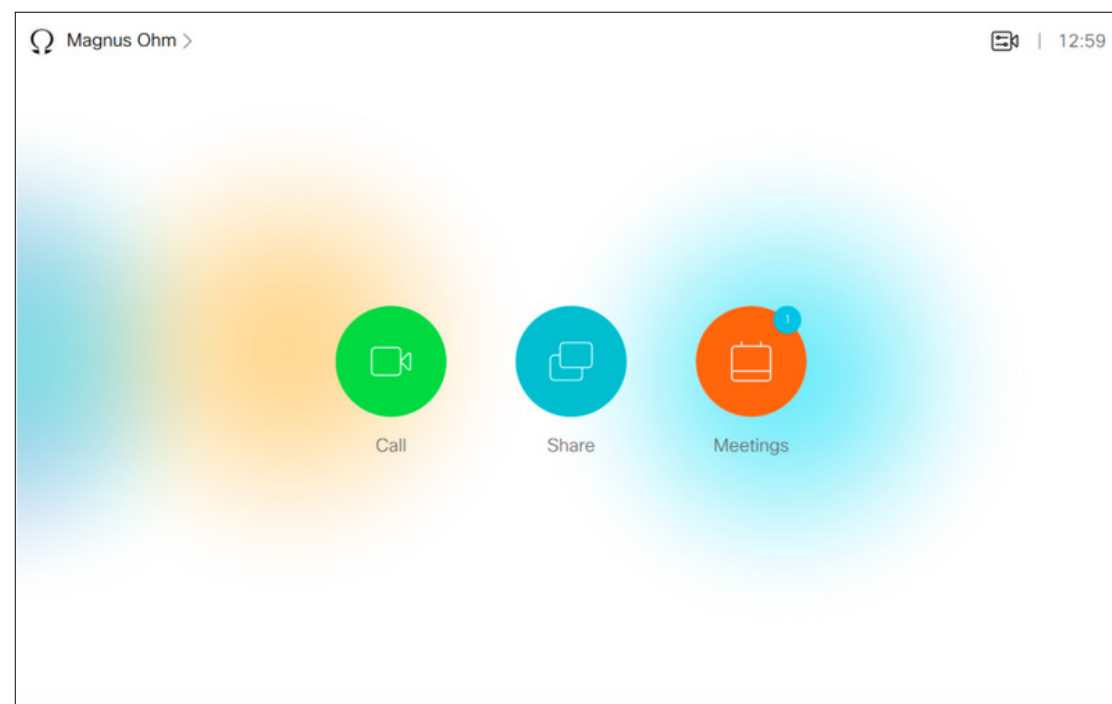

If we now issue the following command:

```
xConfiguration UserInterface Features HideAll: True
```

the UI will look like this:

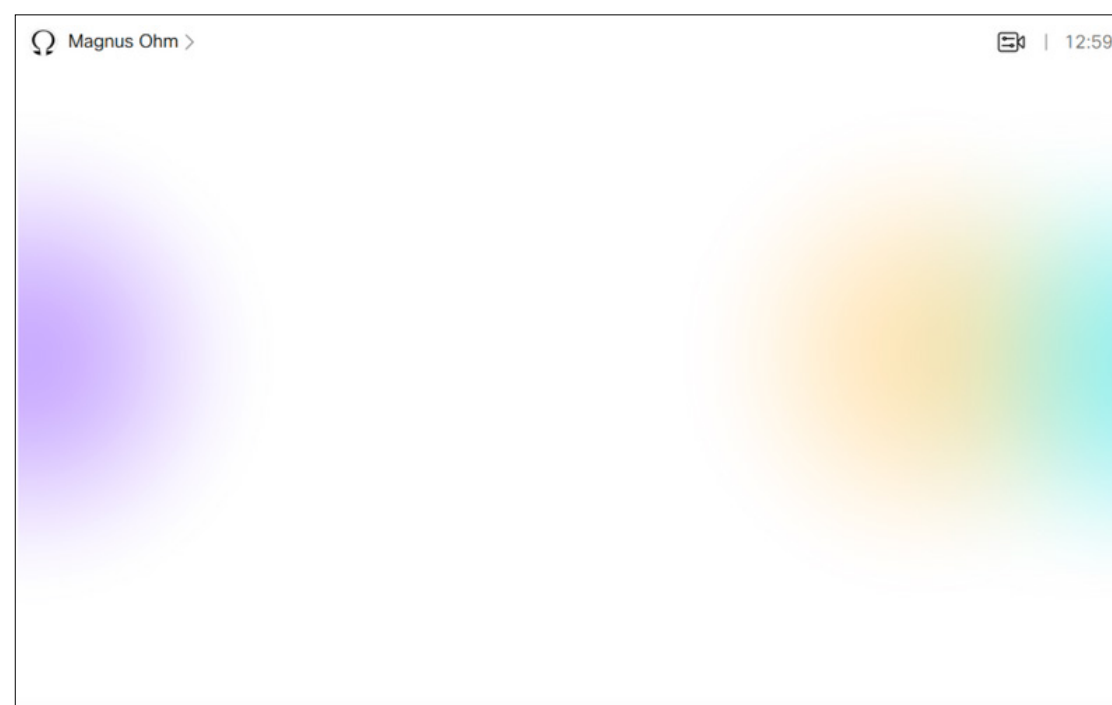

Not very user-friendly, we shall therefore introduce a little In-Room Control magic.

Now, let's open the In-Room Control editor and create this panel:

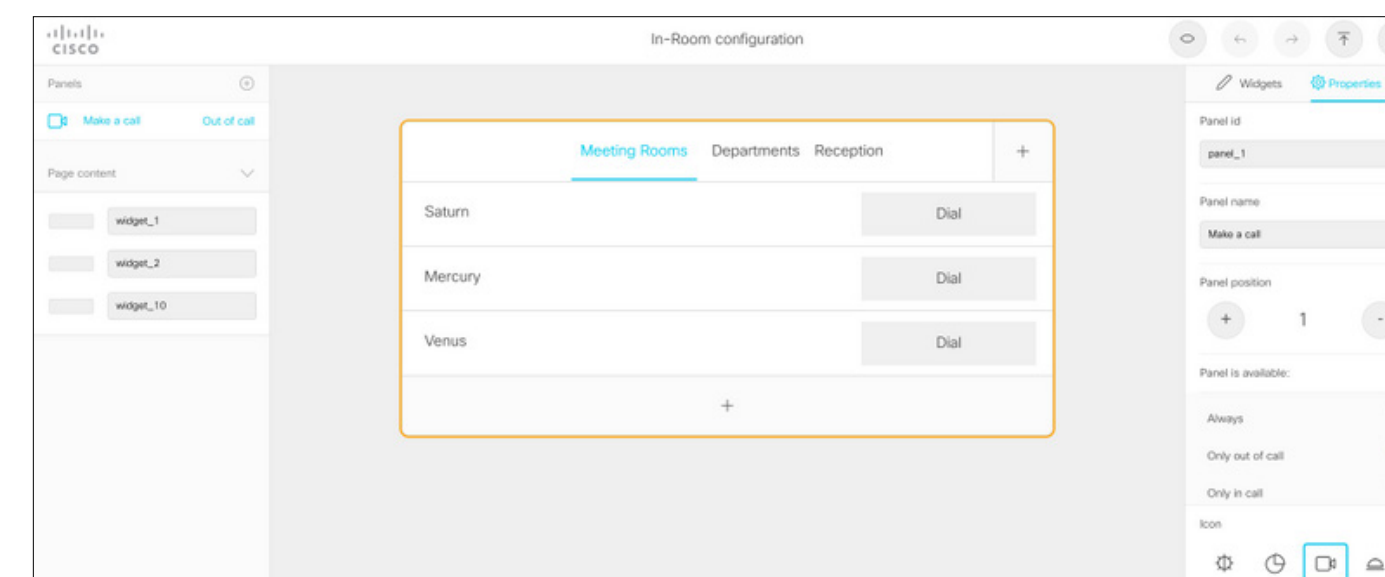

The name of the Panel is **Make a Call**, and that is what will appear below the button, once we've pushed the design to the codec:

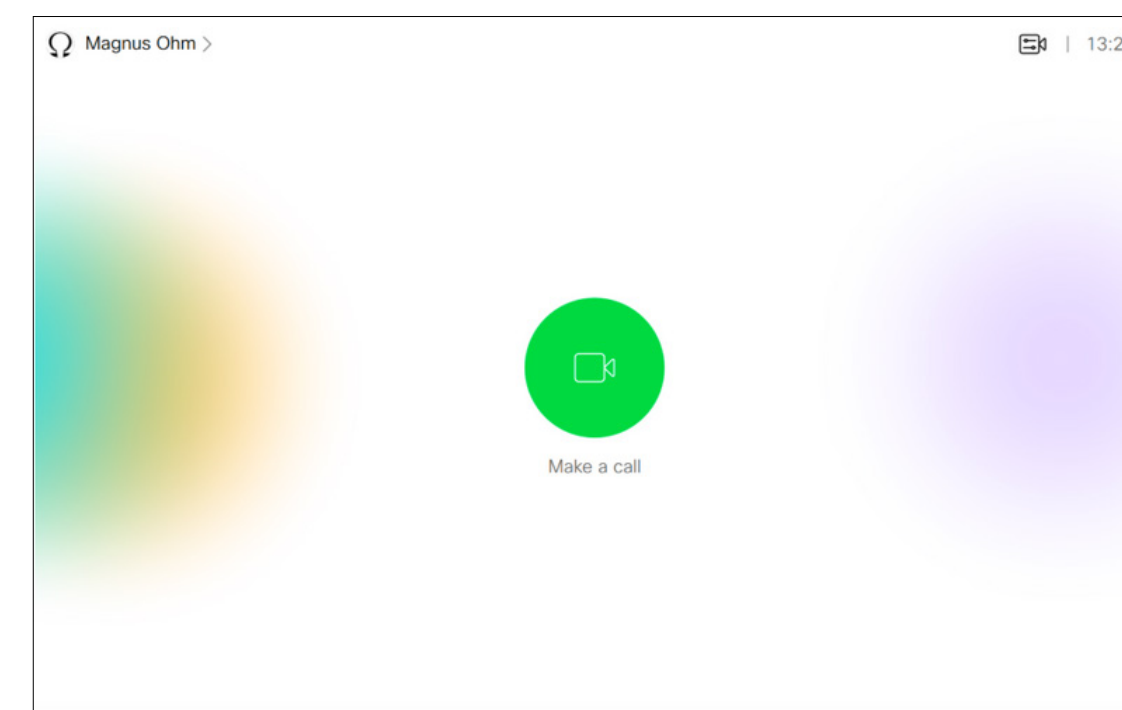

If you now tap the **Make a call** button, the following panel will appear:

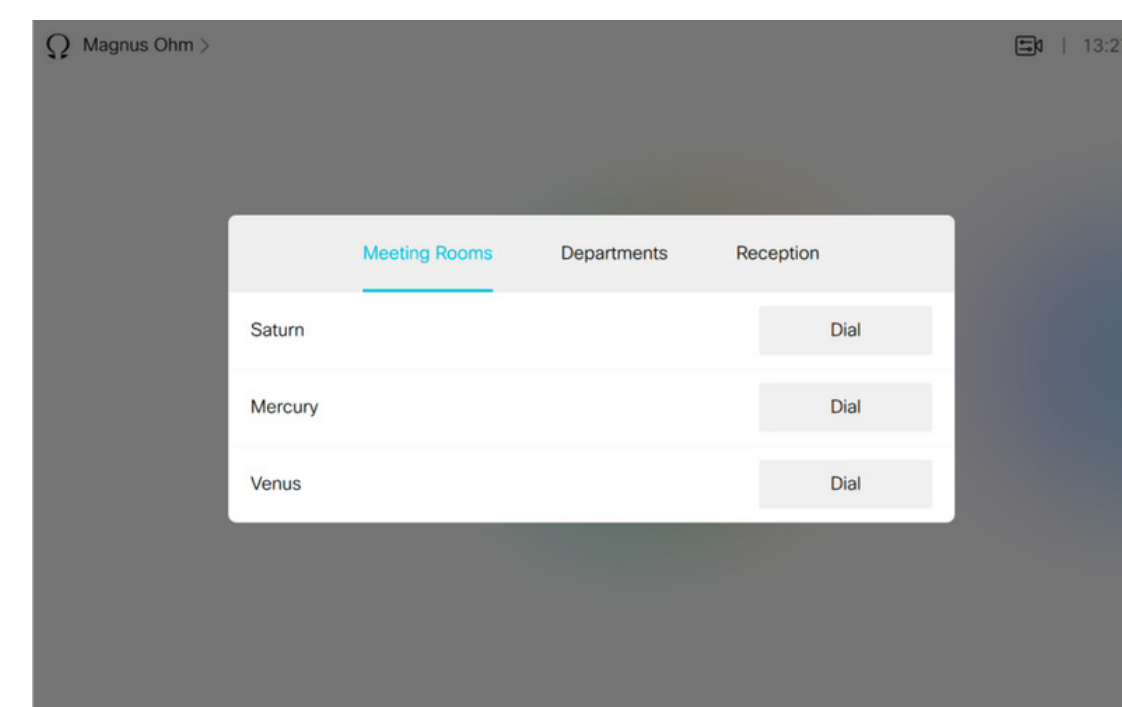

As a user there is not much that you will be able to do here, but that's intentional. No mistakes or random calls possible. To call any of the three rooms possible just tap **Make a Call** followed by **Dial** next to the name of the room to be called.

To actually create and use this In-Room Control panel you will either need an external control device or create a Macro. Macros are described in the Macros section of this document.

This was an out-of-call example. Note that since we used the HideAll and introduced a panel that becomes effective outside calls only, the in-call behavior has been left undefined.

This must be dealt with, and on the next page we provide an in-call example rectifying this.

An In-Call Example

Scenario

As described on the previous page, we need to define in-call behavior as well. Otherwise, we will meet the following when in a call (no way to end the call):

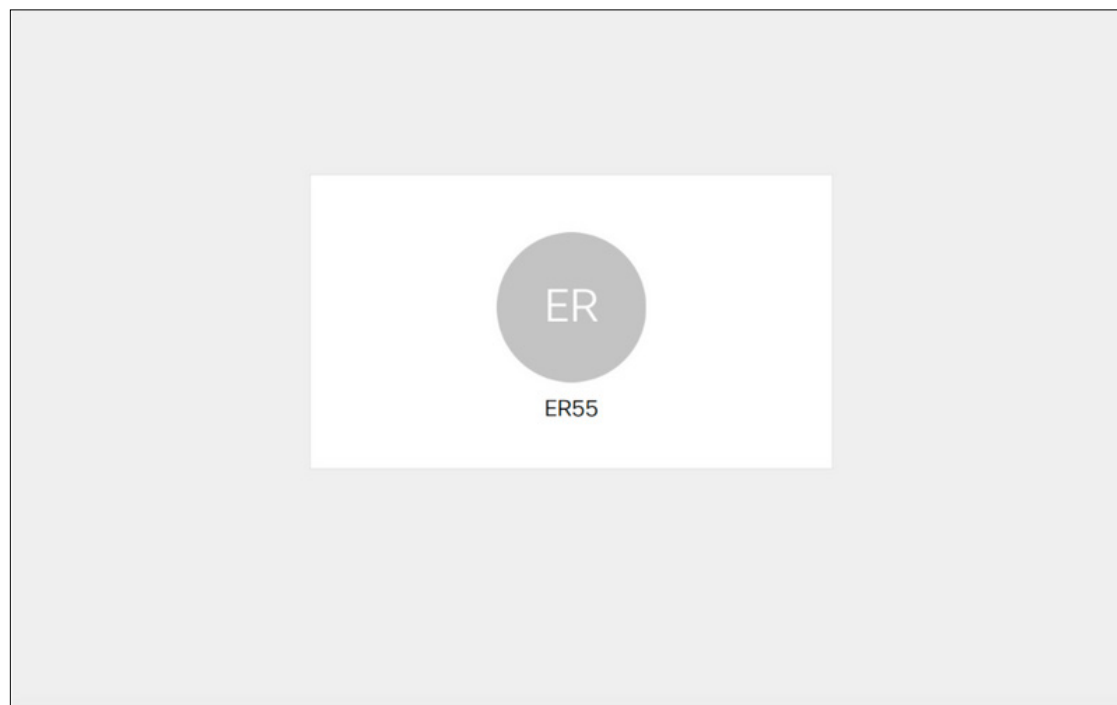

In this example, once you tap the **Call control** button, the following will be displayed:

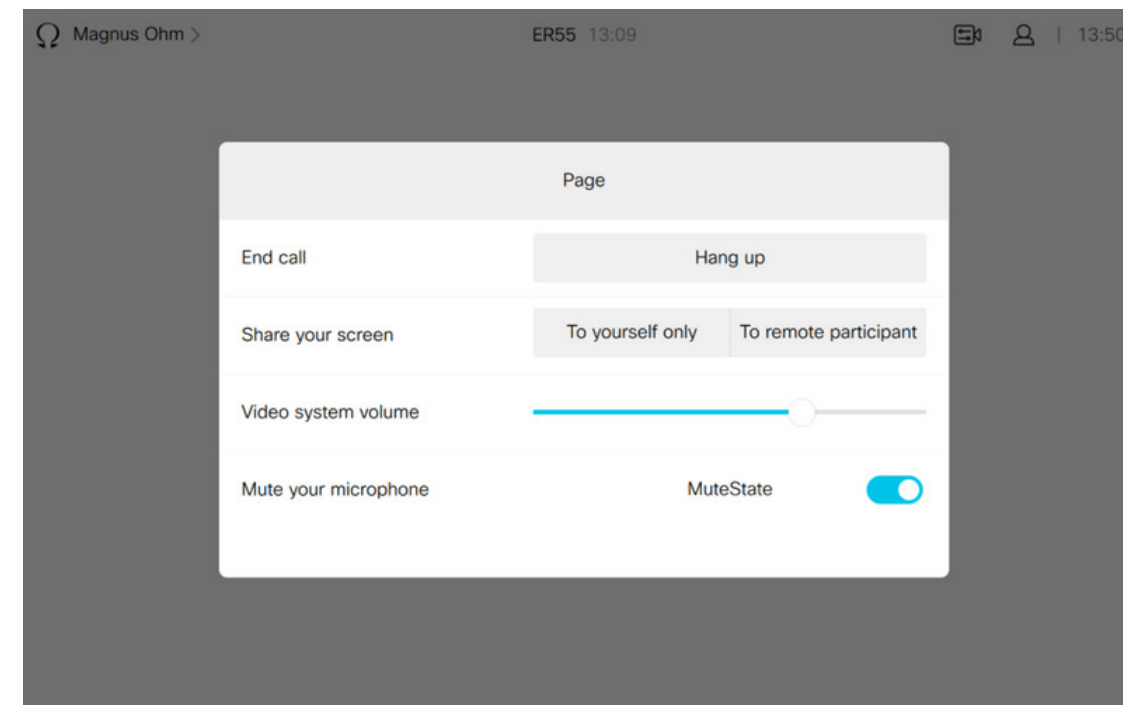

Let's create a setup:

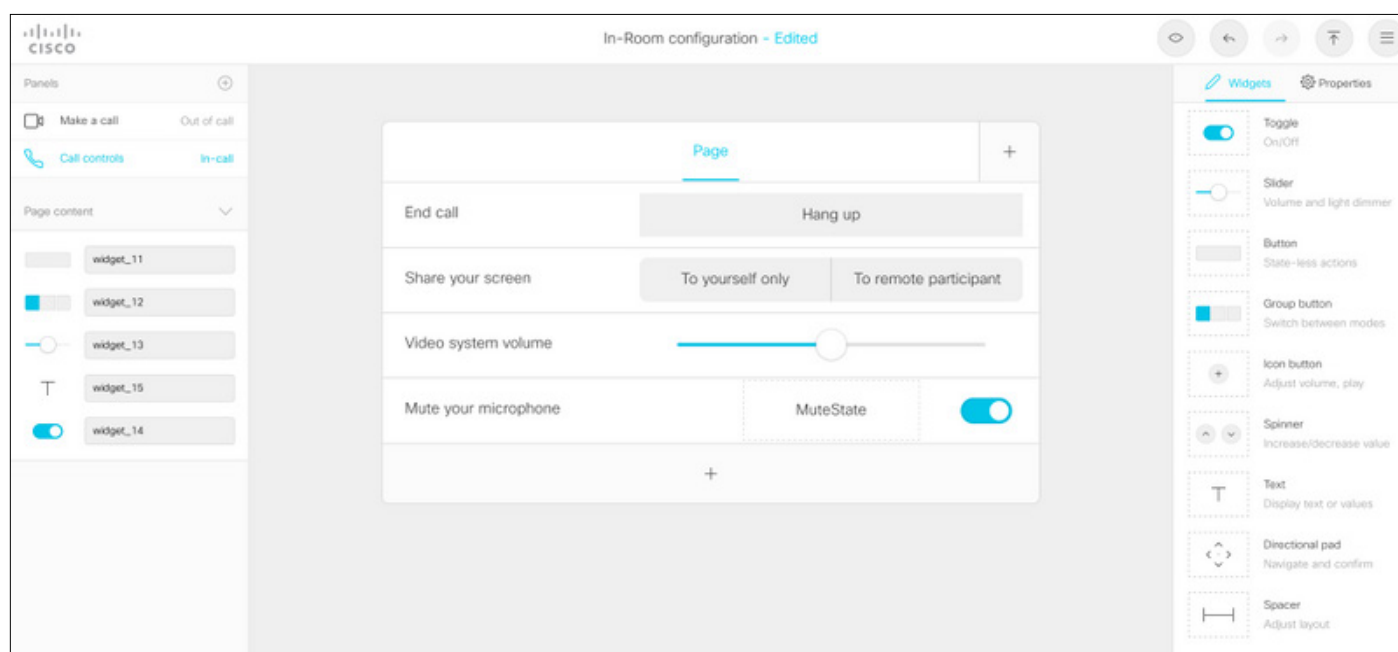

Note! The examples outlined in this chapter are just examples. There are lots of ways to create such scenarios.

This button is set to appear in calls only. Push this to the codec and the required functionality will be available:

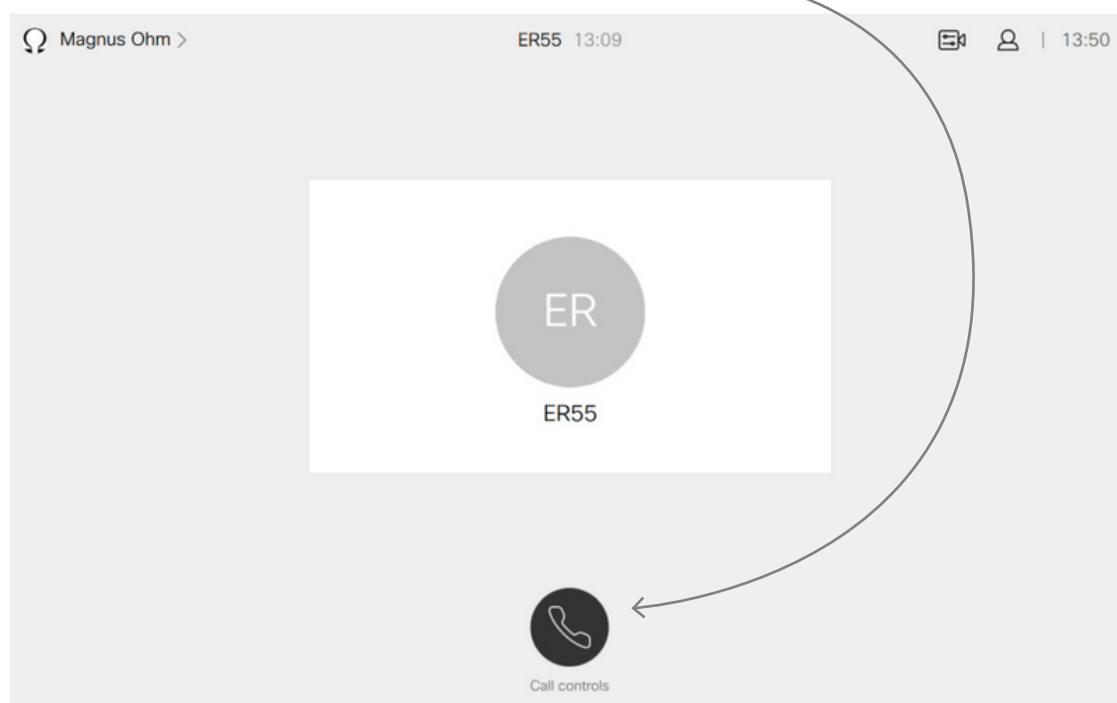

Command Reference

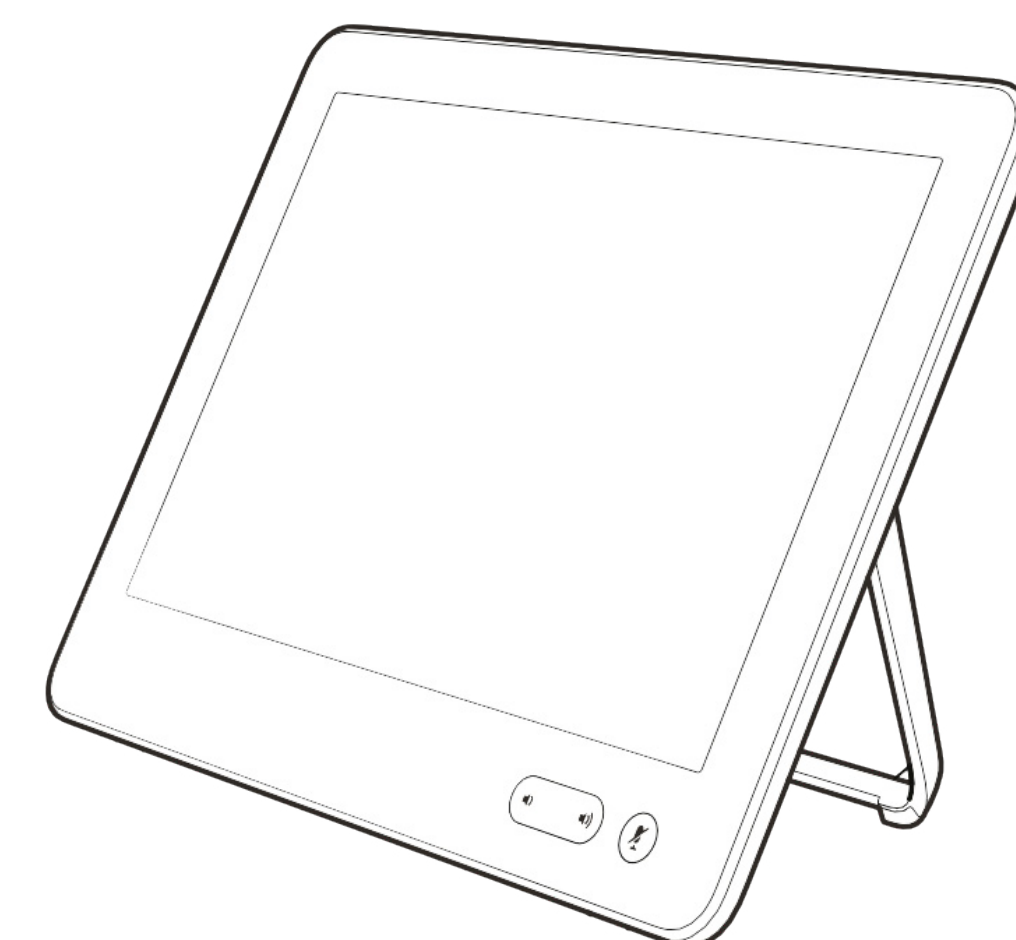

Events

UserInterface Extensions Event Pressed

Sent by the video system when a widget is first pressed.

Equivalent to the UserInterface Extensions Widget Action event with Type “Pressed”.

*e UserInterface Extensions Event Pressed Signal: Signal

in which

Signal: String (0, 255)

The format of the string is “<WidgetId>:<Value>”, where <WidgetId> is the unique identifier of the widget that triggers the event, and <Value> is the value of the widget. The range of allowed values depends on the widget type.

UserInterface Extensions Event Changed

Sent by the video system when changing a widget’s value (applies only to toggle buttons and sliders).

Equivalent to the UserInterface Extensions Widget Action event with Type “Changed”.

*e UserInterface Extensions Event Changed Signal: Signal

in which

Signal: String (0, 255)

The format of the string is “<WidgetId>:<Value>”, where <WidgetId> is the unique identifier of the widget that triggers the event, and <Value> is the value of the widget. The range of allowed values depends on the widget type.

UserInterface Extensions Event Released

Sent by the video system when a widget is released (even if moving the finger out of the widget before releasing it).

Equivalent to the UserInterface Extensions Widget Action event with Type “Released”.

*e UserInterface Extensions Event Released Signal: Signal

in which

Signal: String (0, 255)

The format of the string is “<WidgetId>:<Value>”, where <WidgetId> is the unique identifier of the widget that triggers the event, and <Value> is the value of the widget. The range of allowed values depends on the widget type.

UserInterface Extensions Event Clicked

Sent by the video system when a widget is clicked (pressed and released without moving the finger out of the widget).

Equivalent to the UserInterface Extensions Widget Action event with Type “Clicked”.

*e UserInterface Extensions Event Clicked Signal: Signal

in which

Signal: String (0, 255)

The format of the string is “<WidgetId>:<Value>”, where <WidgetId> is the unique identifier of the widget that triggers the event, and <Value> is the value of the widget. The range of allowed values depends on the widget type.

Events (Cont.)

UserInterface Extensions Widget Action

Sent by the video system when someone uses one of the controls on the user interface (in-room control panel).

Equivalent to the UserInterface Extensions Event *Type* event.

Depending on the action type, this event is equivalent to one of these events:

- UserInterface Extensions Event Pressed
- UserInterface Extensions Event Changed
- UserInterface Extensions Event Released
- UserInterface Extensions Event Clicked Events

```
<Event>
  <UserInterface item="1">
    <Extensions item="1">
      <Widget item="1">
        <Action item="1">
          <WidgetId item="1">WidgetId</WidgetId>
          <Value item="1">Value</Value>
          <Type item="1">Type</Type>
        </Action>
      </Widget>
    </Extensions>
  </UserInterface>
</Event>
```

in which:

WidgetId: String (0, 40)

The unique identifier for the widget that triggered the event.

Value: String (0, 255)

The value of the widget. The range of allowed values depends on the widget type.

Type: <Pressed/Changed/Released/Clicked>

Pressed: Sent when a widget is first pressed.

Changed: Sent when changing a widget's value (only for toggle buttons and sliders).

Released: Sent when a widget is released (even if moving the finger out of the widget before releasing it).

Clicked: Sent when a widget is clicked (pressed and released without moving the finger out of the widget).

UserInterface Extensions Widget LayoutUpdated

Sent by the video system when the configuration file for the user interface extensions has been updated, i.e. when exporting a new configuration from the in-room control editor to the video system.

*e UserInterface Extensions Widget LayoutUpdated

or

```
<Event>
  <UserInterface item="1">
    <Extensions item="1">
      <Widget item="1">
        <LayoutUpdated item="1"/>
      </Widget>
    </Extensions>
  </UserInterface>
</Event>
```

Commands

UserInterface Extensions Widget SetValue

This command sets the value of the given widget, and the UserInterface Extensions statuses are updated accordingly. If the value is out of range, the command returns an error.

USAGE:

```
xCommand UserInterface Extensions Widget SetValue Value: Value  
WidgetId: WidgetId
```

in which

Value: String (0, 255)

The value of the widget. The range of values depends on the widget type.

WidgetId: String (0, 40)

The unique identifier for the widget.

UserInterface Extensions Widget UnsetValue

This command empties the value of the given widget, and the UserInterface Extensions statuses are updated accordingly. The user interface is notified that the widget is no longer selected.

USAGE:

```
xCommand UserInterface Extensions Widget UnsetValue WidgetId:  
WidgetId
```

in which

WidgetId: String (0, 40)

The unique identifier for the widget.

UserInterface Extensions Clear

This command deletes all user interface extensions (widgets) from the video system.

USAGE:

```
xCommand UserInterface Extensions Clear
```

UserInterface Extensions List

Use this command to list all user interface extensions (widgets) that exist on the video system.

USAGE:

```
xCommand UserInterface Extensions List
```

Statuses

UserInterface Extensions Widget [n] WidgetId

UserInterface Extensions Widget [n] Value

This status returns the identifier (*WidgetId*) and the current value of the widgets.

The value is an empty string until a value is set by using the `UserInterface Extensions Widget SetValue` command.

USAGE:

```
xStatus UserInterface Extensions
```

Value space of the result returned:

Value: The value of the widget. Depends on widget type. String (0, 255).

WidgetId: The unique widget identifier. String (0, 40).

Example:

```
xstatus UserInterface Extensions
*s UserInterface Extensions Widget 1 Value: "on"
*s UserInterface Extensions Widget 1 WidgetId: "togglebutton"
*s UserInterface Extensions Widget 2 Value: "255"
*s UserInterface Extensions Widget 2 WidgetId: "slider"
*s UserInterface Extensions Widget 3 Value: "Blinds"
*s UserInterface Extensions Widget 3 WidgetId: "spinner"
*s UserInterface Extensions Widget 4 Value: "inactive"
*s UserInterface Extensions Widget 4 WidgetId: "button"
*s UserInterface Extensions Widget 5 Value: "2"
*s UserInterface Extensions Widget 5 WidgetId: "groupbutton"
*s UserInterface Extensions Widget 6 Value: "Projector is
  ready"
*s UserInterface Extensions Widget 6 WidgetId: "textfield"
** end
```

Creating Interactive Messages



How Interactive Messages Work (I)

Example 1—Rating Your Experience

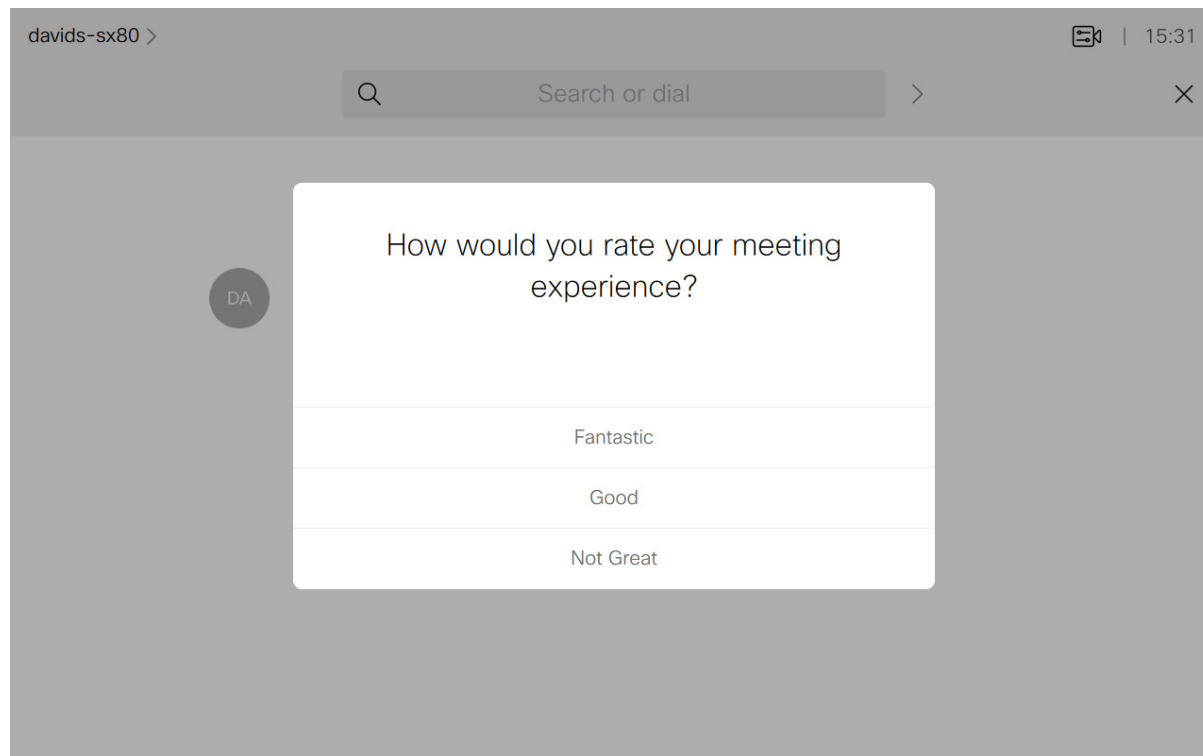

```
xCommand UserInterface Message Prompt Display FeedbackId:
  "MeetingExperience" Text: "" Title: "How would you rate your meeting
  experience?" Option.1: "Fantastic" Option.2: "Good" Option.3: "Not
  Great"
```

```
*e UserInterface Message Prompt Response FeedbackId: "MeetingExperience"
```

```
*e UserInterface Message Prompt Response OptionId: 1
```

```
<XmlDoc resultId="">
<Event>
  <UserInterface item="1">
    <Message item="1">
      <Prompt item="1">
        <Response item="1">
          <FeedbackId item="1">MeetingExperience</FeedbackId>
          <OptionId item="1">1</OptionId>
        </Response>
      </Prompt>
    </Message>
  </UserInterface>
</Event>
</XmlDoc>
```

Example 2—Write Your Feedback Here

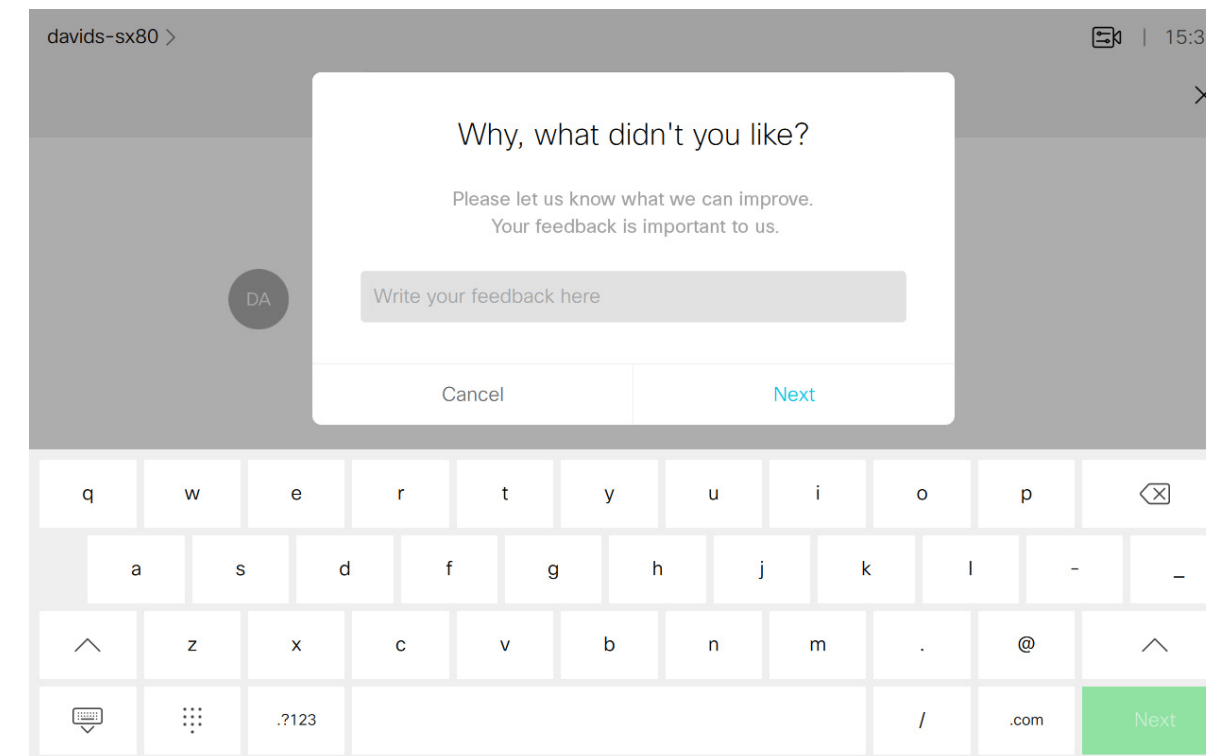

```
xCommand UserInterface Message TextInput Display FeedbackId:
  "MeetingFeedback" Placeholder: "Write your feedback here" SubmitText:
  "Next" Title: "Why, what didn't you like?" Text: "Please let us know
  what we can improve. Your feedback is important to us."
```

```
*e UserInterface Message TextInput Response FeedbackId:
  "MeetingFeedback"
```

```
*e UserInterface Message TextInput Response Text: "Low resolution"
```

```
<XmlDoc resultId="">
<Event>
  <UserInterface item="1">
    <Message item="1">
      <TextInput item="1">
        <Response item="1">
          <FeedbackId item="1">MeetingFeedback</FeedbackId>
          <Text item="1">Low resolution</Text>
        </Response>
      </TextInput>
    </Message>
  </UserInterface>
</Event>
</XmlDoc>
```

The Messages feature lets you create alerting and/or interactive messages on the Touch10/DX/Webex Board screen prompting the user to act accordingly.

If you want to create a sequence of messages where the next message depends on a choice made in the previous message, we recommend the use of macros to create events to act upon. Alternatively, you may use an external control device, which then will act upon the events created.

In order to submit inputs from the user, you should make use of HttpFeedback.

The HttpFeedback enables you to get the device to post http feedback messages (also known as webhooks) upon changes to the API state, e.g. statuses, events and configuration updates. The HTTP Post feedback messages will be sent to the specified ServerURL.

More about this can be found in the API Reference Guide.

Note that when you create messages as shown in example 2, at left, you may specify the text on the "Next" button. The "Cancel" button, however, appears by default and its text cannot be altered.

When you create messages using Message Alert as in example 4 (on the next page), the "Dismiss" button will appear by default. The text on this button cannot be altered.

How Interactive Messages Work (II)

Example 3—Getting In Touch With You

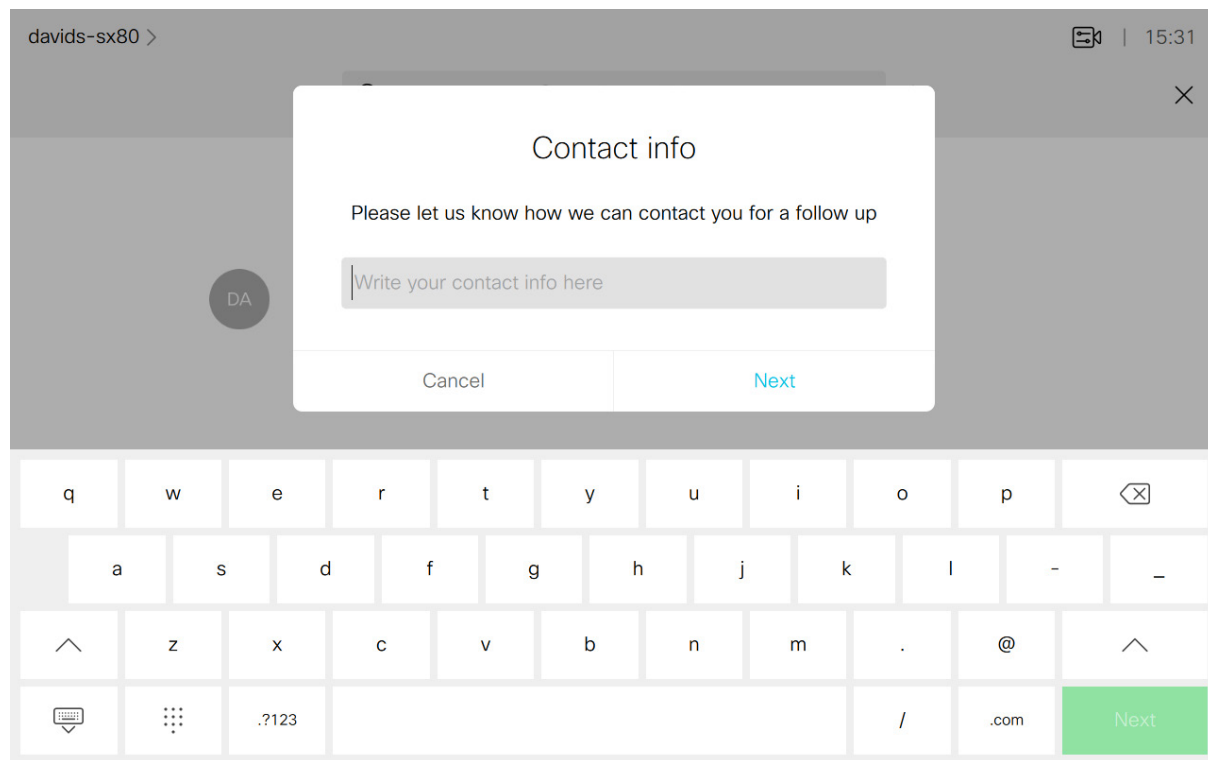

```
xCommand UserInterface Message TextInput Display FeedbackId:
  "ContactInfo" Placeholder: "Write your contact info here" SubmitText:
  "Next" Title: "Contact Info" Text: "Please let us know how we can
  contact you for a follow up"
```

```
*e UserInterface Message TextInput Response FeedbackId: "ContactInfo"
*e UserInterface Message TextInput Response Text: "john@go.webex.com"
<XmlDoc resultId="">
<Event>
  <UserInterface item="1">
    <Message item="1">
      <TextInput item="1">
        <Response item="1">
          <FeedbackId item="1">ContactInfo</FeedbackId>
          <Text item="1">john@go.webex.com</Text>
        </Response>
      </TextInput>
    </Message>
  </UserInterface>
</Event>
</XmlDoc>
```

Example 4—Feedback Receipt

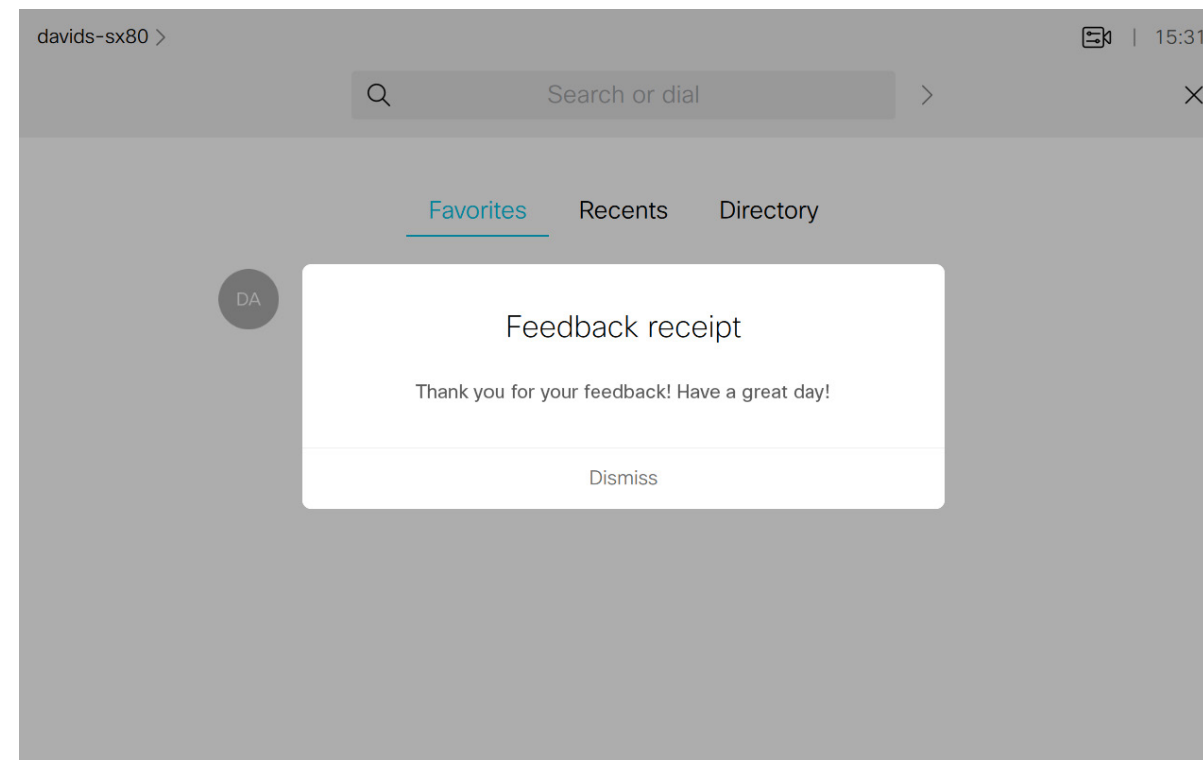

```
xCommand UserInterface Message Alert Display Title: "Feedback receipt"
  text: "Thank you for your feedback! Have a great day!"
```

```
*e UserInterface Message Alert Cleared
```

```
<XmlDoc resultId="">
<Event>
  <UserInterface item="1">
    <Message item="1">
      <Alert item="1">
        <Cleared item="1"/>
      </Alert>
    </Message>
  </UserInterface>
</Event>
</XmlDoc>
```

Example 5—Enter Your WebEx Pin

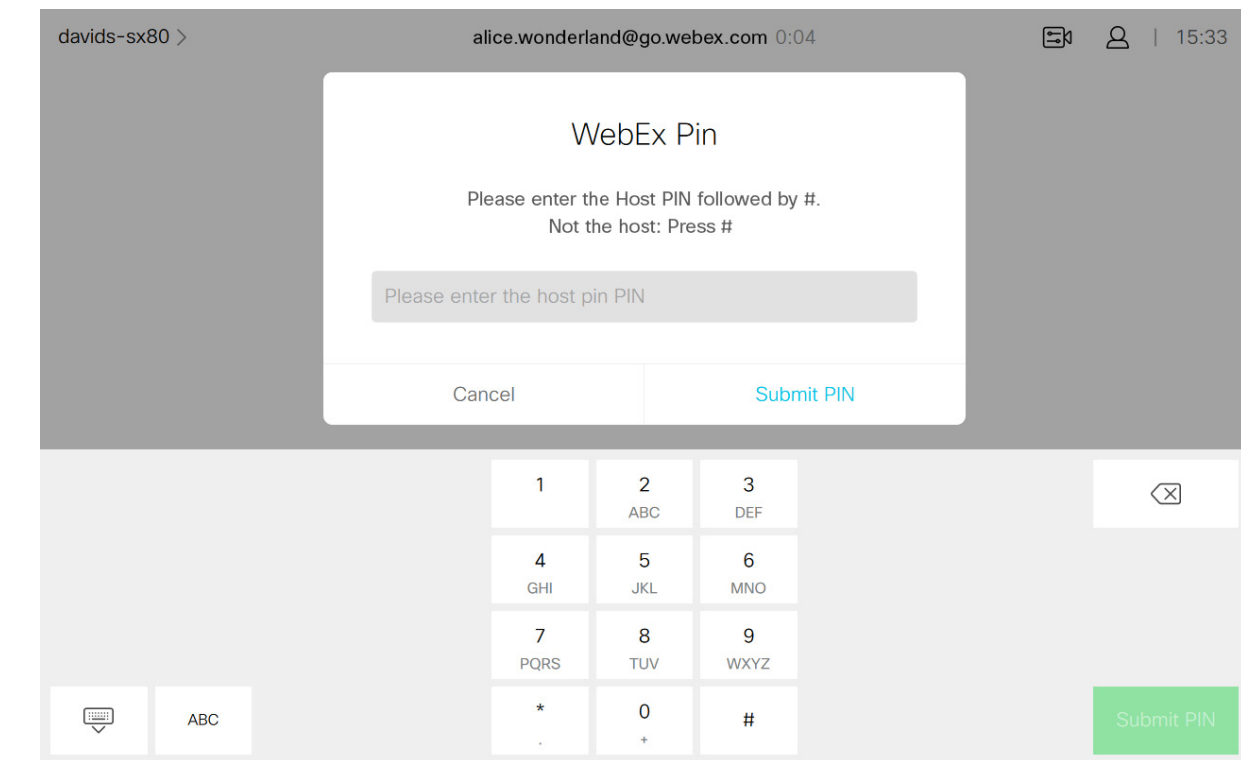

```
xCommand UserInterface Message TextInput Display FeedbackId: "WebExPin"
  InputType: Numeric Placeholder: "Please enter the host pin PIN"
  SubmitText: "Submit PIN" Text: "Please enter the host pin PIN,
  followed by #. Not the host: Press #" Title: "WebEx Pin"
```

```
*e UserInterface Message TextInput Response FeedbackId: "WebExPin"
*e UserInterface Message TextInput Response Text: "1122#"
```

```
<XmlDoc resultId="">
<Event>
  <UserInterface item="1">
    <Message item="1">
      <TextInput item="1">
        <Response item="1">
          <FeedbackId item="1">WebExPin</FeedbackId>
          <Text item="1">1122#</Text>
        </Response>
      </TextInput>
    </Message>
  </UserInterface>
</Event>
</XmlDoc>
```

HTTP(S) Requests

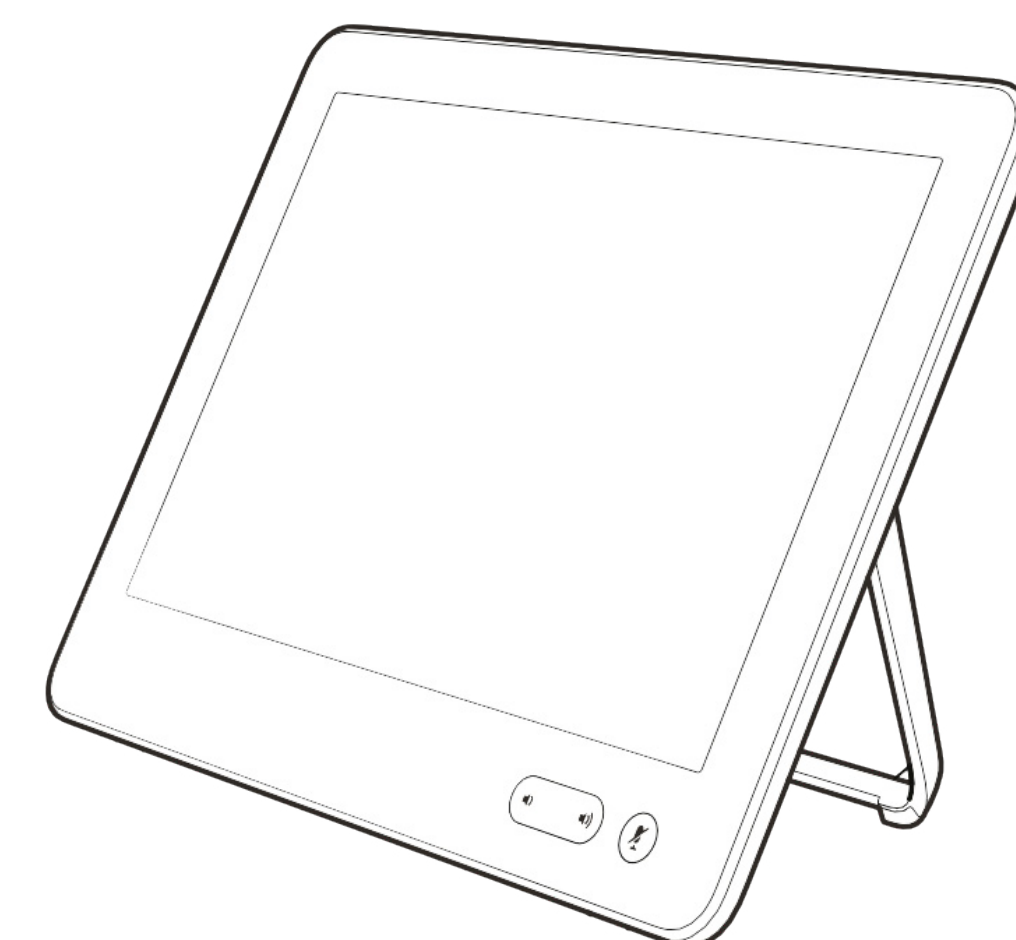

Sending HTTP(S) Requests **REVISED**

What Is It?

This feature makes it possible to send arbitrary HTTP(S) Post and Put requests from a video system to an HTTP(S) server.

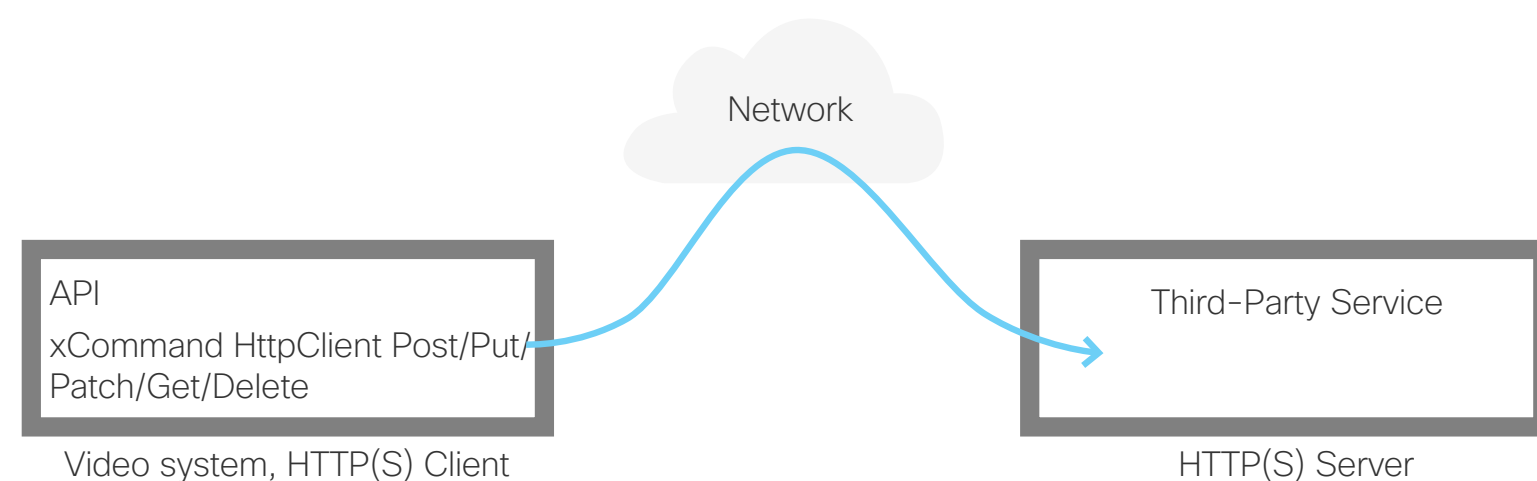

By using macros, you can send data to an HTTP(S) server whenever you want. You can choose what data to send, and structure them as you like. In this way you can adapt the data to an already established service.

Security measures:

- The HTTP(S) Post/Put feature is disabled by default. A system administrator must explicitly enable the feature by setting `HttpClient > Mode` to On.
- The system administrator can inhibit the use of HTTP by setting `HttpClient > AllowHTTP` to False
- The system administrator can specify a list of HTTP(S) servers that the video system is allowed to send data to (see the `xCommand HttpClient Allow Hostname` commands).
- The number of concurrent Post and Put requests is limited.

List of Allowed HTTP(S) Servers

The system administrator can use these commands to set up and maintain a list of up to ten allowed HTTP(S) servers (hosts):

- `xCommand HttpClient Allow Hostname Add Expression: <Regular expression that matches the host name or IP address of the HTTP(S) server>`
- `xCommand HttpClient Allow Hostname Clear`
- `xCommand HttpClient Allow Hostname List`
- `xCommand HttpClient Allow Hostname Remove Id: <id of an entry in the list>`

If the list is not empty, you can send HTTP(S) requests to the servers in the list only. If the list is empty, you can send the requests to any HTTP(S) server.

The check against the list of allowed servers is performed both when using insecure (HTTP) and secure (HTTPS) transfer of data.

Allowing HTTPS without certificate validation

When sending requests over HTTPS, the video system checks the certificate of the HTTPS server by default. If the HTTPS server certificate is not found to be valid, you will get an error message. The video system will not send any data to that server.

We recommend using HTTPS with certificate validation. If this is not possible, the system administrator can set `HttpClient > AllowInsecureHTTPS` to On (`xConfiguration HttpClient AllowInsecureHTTPS: On`), which allows the use of HTTPS without validating the server's certificate.

Sending HTTP(S) Requests

Once the HTTP(S) Client Post feature is enabled, you can use the following commands to send requests to an HTTP(S) server. In the below text `<Method>` is either Post, Put, Patch, Get or Delete:

- `xxCommand HttpClient <Method> [AllowInsecureHTTPS: <True/False>] [Header:<Header text>] [ResponseSizeLimit: <Maximum response size>] [ResultBody: <None/PlainText/Base64>] [Timeout: <Timeout period>] Url: <URL to send the request to>`

Adding header fields is optional, but you can add as many as twenty fields.

The `AllowInsecureHTTPS` parameter is effective only if the system administrator has allowed the use of HTTPS without validating the server's certificate. If so, you can send data to the server without validating the server certificate if the parameter is set to True. If you leave out the parameter, or set it to False, data is not sent if the certificate validation fails.

The `ResponseSizeLimit` parameter is the maximum payload size (bytes) that the device accepts as a response from the server. If the response payload is larger than this maximum size, the command returns a status error with a message saying that the maximum file size is exceeded. However, this has no effect on the server side; the request was received and processed properly by the server.

Use the `ResultBody` parameter to decide how to format the body of the HTTP response from the server in the command result. You have three options:

- None:** Don't include the body of the HTTP response in the command result.
- Base64:** Base64 encode the body before including it in the result.
- PlainText:** Include the body in the result as plain text. If the response contain non-printable letters, the command returns a status error with a message saying that non-printable data was encountered.

Use the `Timeout` parameter to set a timeout period (seconds). If the request is not completed during this period, the API will return an error.

Enter the payload (data) right after you have issued the command. Anything that you enter, including line breaks, is part of the payload. When done, finish with a line break ("`\n`") and a separate line containing just a period followed by a line break ("`\n`"). Now the command is executed, and the data is sent to the server.

Further Information

All commands and configurations are described in detail in the API guide for your product.

Examples

The body of the message is JSON in both these examples. It could be any format, depending on the expected format of the service that is receiving the messages.

Example 1: IoT Device control using HTTP Post

Here is a macro function that turns on a light that is connected to a Philips Hue Bridge:

```
function hue_command(data) {
    var url = 'http://192.0.2.10/api/' ZX1U4tUtQ23Pjbdyl-kiyCjTs0i5ANDEulypJq0-/lights/1/state';
    var headers = 'Content-Type: application/json';
    var command = '{"on":true}';

    xapi.command('HttpClient Put', { 'Url': url, 'Header': headers },
    command);
}
```

You can do the same at the command line using the API:

```
xcommand HttpClient Put Header: "Content-Type: application/json" URL:
"http://192.0.2.10/api/' ZX1U4tUtQ23Pjbdyl-kiyCjTs0i5ANDEulypJq0-/
lights/1/state"
{"on":true}
.
```

Example 2: Posting data to a monitoring tool using HTTP Post

```
xcommand HttpClient Post Header: "Content-Type: application/json" URL:
"https://mymonitoringserver.com/service/devicemonitoring"
{"Message":"A user reported an issue with this
system","systemName":"BoardRoom 4th floor","softwareVersion":"ce9.6.0",
softwareReleaseDate":"2018-06-29","videoMonitors":"Dual"}
```

Troubleshooting



Tips When Troubleshooting

Sign In

Sign in to the video system's web interface with administrator credentials, navigate to **Integration > In-Room Control**. Click the arrow to show the **Development Tools**.

Overview of all Widgets and Their Status

The **Widget State Overview** window lists all widgets, and their status. The status is shown in the **Current Value** column.

If the **Current Value** column is empty, the widget has not been initialized and has no value. We recommend that the control system initializes all widgets when it initially connects to the video system.

Send Value Updates to the Video System

A control system sends `SetValue` commands to the video system, telling it to update a widget. For test purposes, you can use the **Update Value** column in the **Widget State Overview** window to simulate a control system.

Enter a value in one of the input fields to immediately send the corresponding `SetValue` command to the video system. The **CurrentValue** column (status) will be updated, and the Touch10 in-room control panel changes accordingly.

Click **Unset** to clear the value of the widget (send an `UnsetValue` command).

If a control system is connected to the video system, the **Current Value** and **Update Value** columns may come out-of-sync. The **Current Value** column always shows the current status, regardless of whether the `SetValue` command is sent from a real control system, or from the **Update Value** column.

Check for Events and Status Updates

All events and status updates related to widgets appear immediately in the **Log** window. Events are prefixed with `*e`, and statuses are prefixed with `*s`.

Events appear when you use the controls on the Touch 10 user interface, and the status is updated when a command, which changes the video system's status, is sent to the video system.

If a Panel Fails to Load

If an existing in-room control panel failed to load automatically on launching the editor, you may manually import the panel(s) from codec or load a local file made with the offline editor.

All alternatives erase any unsaved data in the editor, but the existing in-room control panel on the video system is neither overwritten nor deleted until a new panel is exported to the video system.

Make Sure That Macros Are Not the Cause

If you experience unintended behavioral changes and you run macros on your system, make sure you deactivate the macros before proceeding with your troubleshooting.

Use `xConfiguration Macros Mode: On/Off` to do this.

The macro framework has its own log file called **macros.log**

The **macros.log** file contains much of what is printed in the Macro console. The macros can be configured to print output to the console and this will be stored in the log, so keep in mind that you can see custom log messages (which must have been created by the developer) in this file.

Tips and Tricks



Recommended Best Practice

Re-register to Get Feedback After Restart

When either the video system or the control system restarts, the control system must re-register to the events that the video system sends when someone uses the In-Room controls or pushes a new In-Room Control panel to the system.

For terminal output mode:

```
xfeedback register event/UserInterface/Extensions/Widget
```

For XML output mode:

```
xfeedback register event/UserInterface/Extensions/Event
xfeedback register event/UserInterface/Extensions/Widget/
  LayoutUpdated
```

Consult the [API for in-room control chapter for more details](#).

Initialize All Widgets

Make sure the control system initializes all the widgets on the In-Room Control panel in the following situations:

- When the control system connects to the video system for the first time
- When the video system restarts
- When the control system restarts
- When a new in-room control panel is exported to the video system (as response to a LayoutUpdated event).

If this is not done, then the system screen may show incorrect values and not truly reflect the status of the room.

Use the `SetValue` command to set the initial values.

Always send values back to the video system when something changes.

To avoid unexpected behavior and ambiguities, the control system must always send `SetValue` commands to the video system when something changes. This applies also when the change is triggered by someone using the controls on the system.

For example, it makes no difference if you use a slider on the In-Room Control panel to dim the light, or a physical dimmer in the room, or another touch panel. The control system must always send the dimmer value back to the video system using the `SetValue` command.

Update the In-Room Control Panel

When you export a new in-room control panel to the video system, the old panel is overwritten and replaced by the new one.

To update, do as follows:

1. Launch the In-Room Control Editor from the video system's web interface.
2. Create the In-Room Control panel you want, or import a previously saved panel from file (**Import > From file**).
3. Click **Export > To codec**.

Other Useful Stuff

Remember previous values when turning lights off (e.g. a light with a slider for dimming and toggle for on/off), remember the current light state when turning off, and use that value when turning back on.

Example: If the light is at 40%, and the user presses off, she will expect it to go back to 40% (not 100%) when pressing the “on” again. Remember also to set the power switch to off if sliding to 0%.

For blinds, consider using the following strategy: Short press on a **Direction** arrow tilts the blinds. If tilted all the way already, a short press moves the blinds slightly.

Long press on a **Direction** arrow starts moving the blind that direction, doesn't stop until blinds are all the way up/down.

To stop movement after long pressing, short press any button (stop button is not really necessary)

Remove Entire In-Room Control Panel and Icon

If there is an In-Room Control panel on the video system then there is also a corresponding In-Room Control icon, either in the Touch 10/DX/Webex Board status bar or as a button to the right of the call control buttons. Even if a panel is empty and contains no widgets, both the icon and the panel will be visible.

Do as follows to remove an In-Room Control panel and icon from system:

1. Launch the In-Room Control editor from the video system's web interface.
2. Select the panel to be removed (Global, Homescreen or In-call)
3. Click **Delete panel**.

Transition From Third-party Control Systems to CE

If you already have been using a third party control system and want to start using CE as described in this document, we recommend the following:

- Let any programming made to control third party stuff remain untouched.
- Remove all code that controls the Cisco video endpoint as that is now already controlled via the In-Room Control.
- Reprogram the signaling from the button-presses coming from the third party control system panel so that it listens to button presses from the Touch10/DX/Webex Board instead.

This programming can be very simple to do as the largest control system manufacturers provide modules/drivers for In-Room Controls making it very easy to get started with the programming.

Recommended Best Practice (cont.)

Inspirational Examples

The following examples may serve as inspiration and to provide further guidance on best practices. It is by no means mandatory to design and implement controls as illustrated in these examples.

Widget ID

When you drag a widget (e.g. a button) onto a page, you may give it a customized ID. Widget IDs do not have to be unique. Widgets can share ID, but they must be of the same type. This means that you can have two sliders in different panels called “main-light”, but you cannot have one slider and one toggle button both called “main-light”.

To create a duplicate of an existing widget on another page or panel, just use Copy and Paste.

Create Groups of What Belongs Together

Consider grouping controls that belong together on the same page. The pages you create in the in-room control editor appear as separate tabs on the control panel.

Control of Lights

The combination of a slider and a toggle button could be used to control lights. The toggle button switches the lights on or off; the slider serves as a dimmer.

Consider the following strategy:

- Set a slider to minimum when the user turns the lights off.
- Set a toggle button to off when the user moves the slider to its minimum.
- Remember the value of the slider when the lights are turned off, so that you can return to this value when the lights are turned back on again.
- If the light is at 40%, when the user switches it off, he or she would expect it to go back to 40% (not maximum) when switching the lights on again.
- When the user selects one of the options in the group button (a light preset), set the sliders and toggle buttons accordingly.
- If the lights are changed away from a preset, for instance by changing a slider or toggle button, deselect all options in the group button.

Control of Temperature

The combination of a spinner and a large font text box (value) may be used to control temperature. Use the spinner to set the desired temperature, and the large font text box to show the current temperature.

For the best user experience keep the following in mind:

- Update the large font text box as the temperature in the room changes. Update the text field of the spinner when someone tap the up and down arrows
- Consult the [Widgets chapter for details about how to update the spinner's text field and the large font text box.](#)

Control of Blinds

You can either use a spinner, or up and down arrows from the Icons tab in the widget library.

Consider the following strategy:

- Tilt the slides as response to a short press on a direction arrow. If tilted all the way, move the blinds up or down incrementally.
- As response to a long press on a direction arrow, start moving the blinds in that direction. They do not stop until all the way up or down.
- Short press any button in order to stop the movement after a long press. Then no separate stop button will be needed.

Group Buttons

Group buttons (radio buttons) are ideal when you want buttons to be linked, so that only one can be selected at a time. For example room presets. When the individual buttons in a group are too small to contain the text that describes their function, consider to use text boxes for the description.

Create Speed Dial or One Button to Push

If you want to create buttons on the screen that directly result in an action without displaying any kind of panels or settings, do as follows:

- Create a new panel and follow the on-screen instructions.

When you tap on the button on the screen, this will directly create an event, which in turn can be used to start an action. Typical examples of use of this feature is Speed Dialing or One Button to Push solutions.

Make sure you give the button a descriptive name for the user, if applicable.

Granting Access to In-Room Control Editor and Extensions API

In order to access the In-Room Control Editor you will need to have administrator rights.

However, an administrator may create an In-Room Control User account. With this account it is possible to log into the codec to run the In-Room Control Editor. No other part of the web interface is accessible from this account.

If you use SSH to log into the codec, only a very limited set of the API will be accessible.

Part 2 Room Simulator



Running the Simulator

In order to make it possible to demonstrate the features of the In-Room Control, we have created a Simulator for you. The purpose of the Simulator is two-fold. It may serve as a sales tool, but it also proves useful if you want to study how commands and events are sent back and forth.

The Simulator contains its own simulated third-party control system. Note that the simulator will look the same, irrespective of which type of video systems you are creating this for (Touch10, DX or Webex Boards).

Used as a Sales Tool

When used as a sales tool to show what this is all about, the Simulator uses a predefined In-Room Control setup. This cannot be changed. The predefined setup will overwrite the setup in the codec. Your current setup will be backed up in your browser and reinstalled after the session (you will be prompted to confirm that).

Note! As the Simulator is self-contained, any controller connected to the codec should be disconnected when running the Simulator to avoid conflicts.

Tip! We recommend using Google Chrome browser when running the Simulator. Other browsers may fail to run the Simulator properly.

To invoke the Simulator navigate to **Integration > In-Room Control** in the web interface and then select **Launch Simulator**:

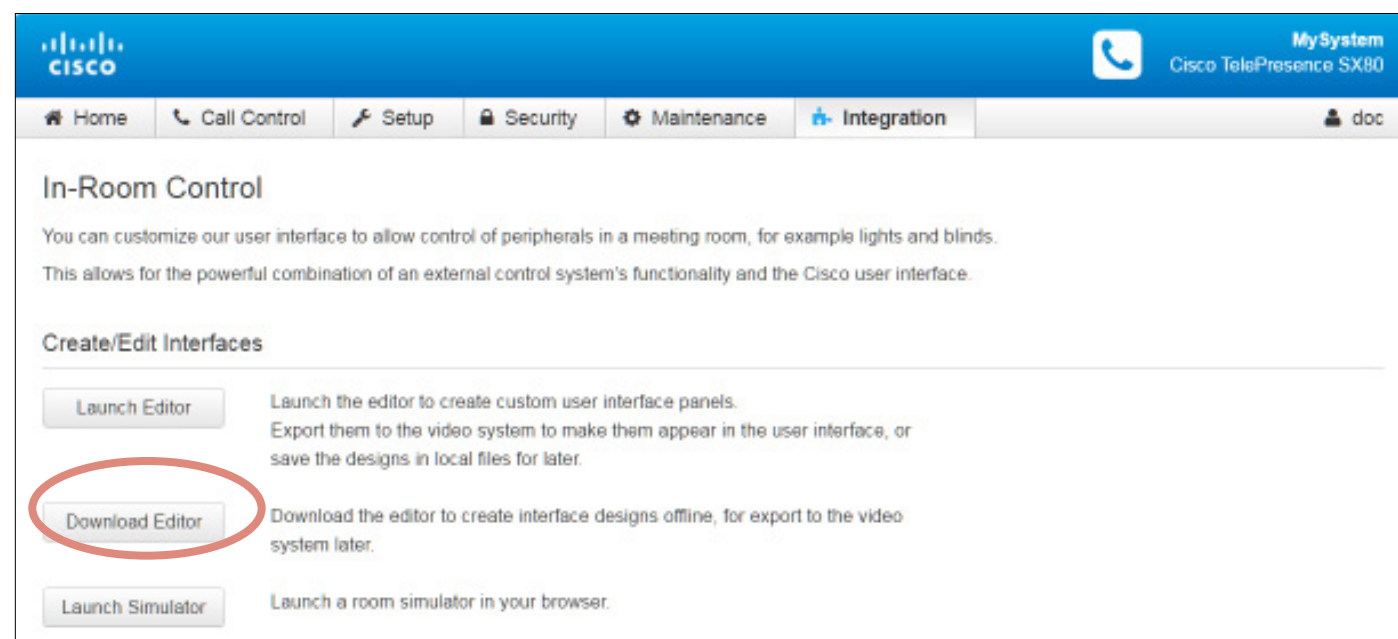

The Example Room will now appear. Click on **Load simulator config**. Once successfully loaded click anywhere to remove messages when needed.

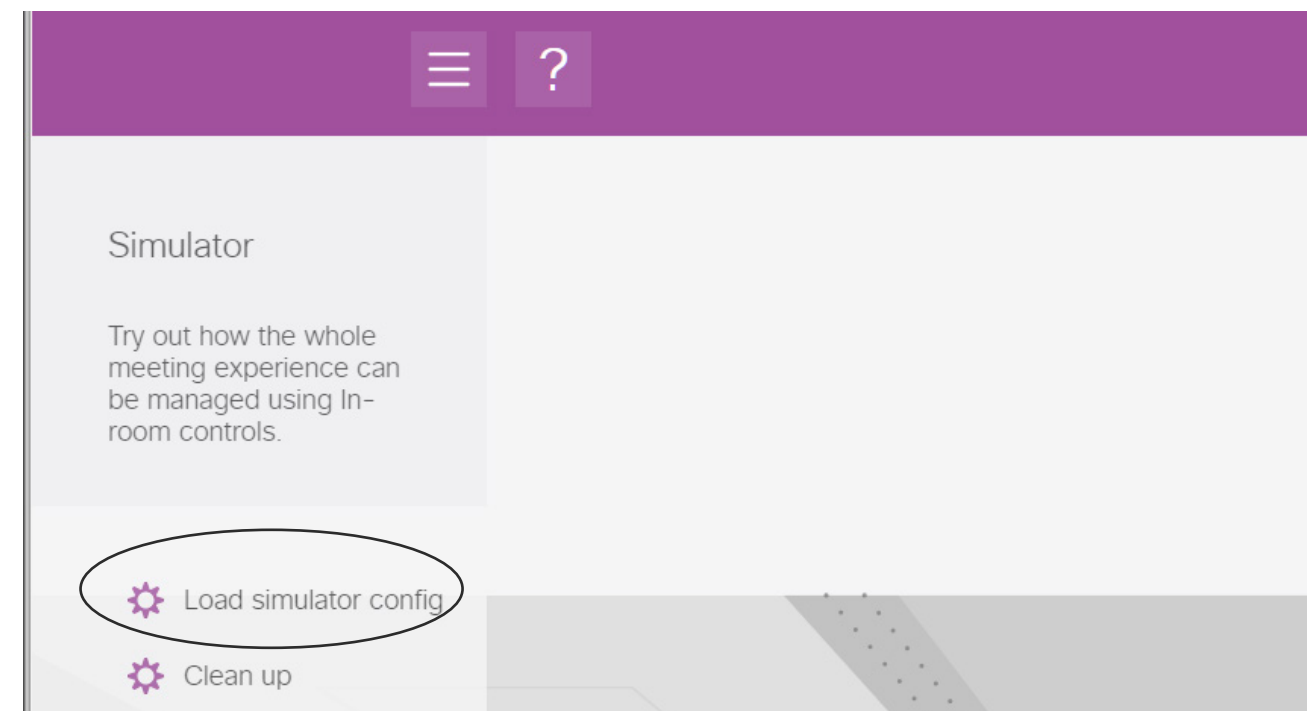

Click on the

Touch10 (1) to enlarge it and then click as shown (2) to invoke the In-Room Controls:

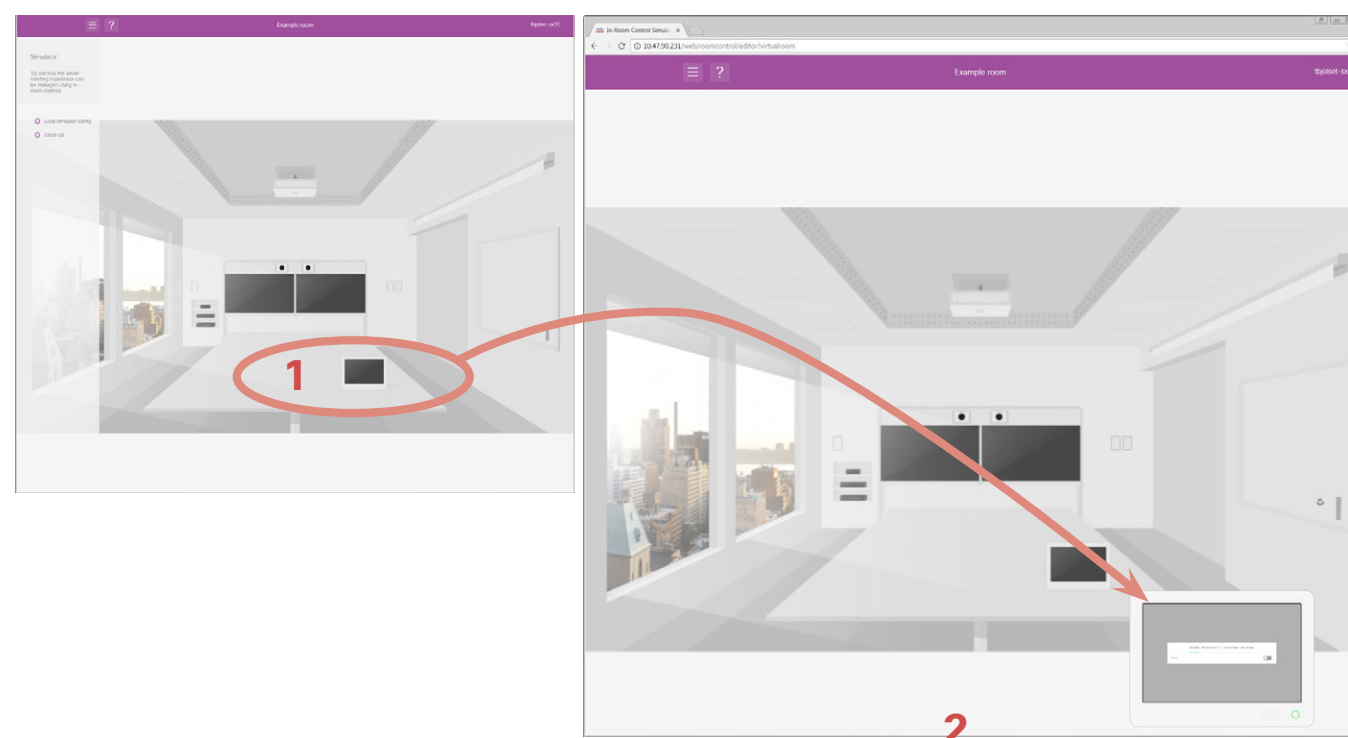

You may now play with the controls on the virtual Touch10, but also with the switches themselves in the room. Click **Clean up** to finish and restore previous settings.

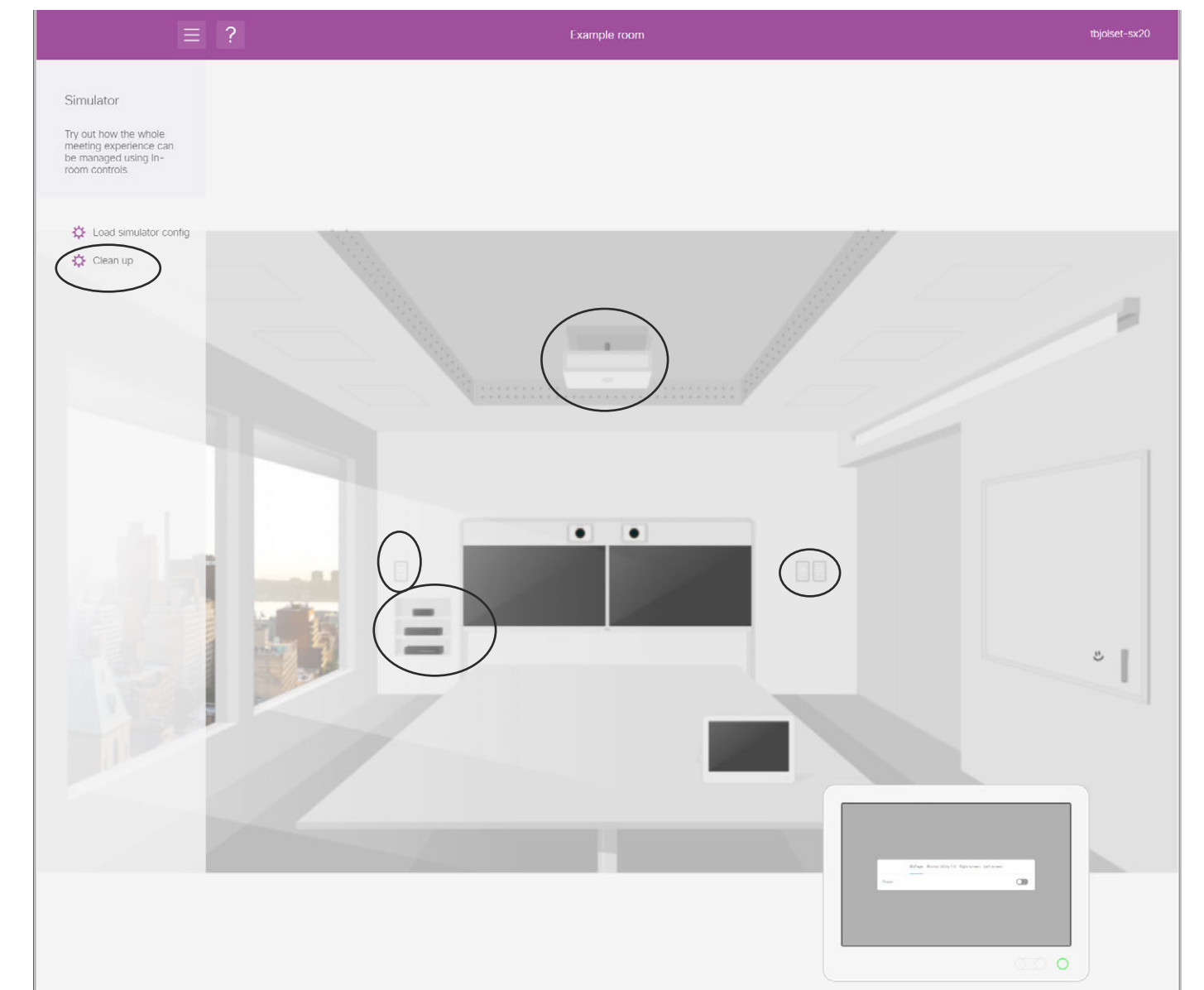

Used as a Preview Simulator

You may also use the simulator to preview the effects of your configuration and to monitor the information interchange between the Touch10 and a simulated third-party control system. Make sure that you have **not** loaded the simulator config into the Simulator. Restore the Codec config, if needed (use **Clean up** as discussed above).

How to use the Preview Simulator is described in "Previewing Your Current Configuration" on page 10.

Part 3

Use of a Video Switch



Using a Third-party Video Switch to Extend the Number of Video Sources Available

The In-Room Control can configure your system to show video sources from a third-party external video switch in the normal Share Tray view.

The sources will appear—and behave—as any other video source connected directly to the codec. For the user this will be perceived as completely transparent—no video switch seems to be involved.

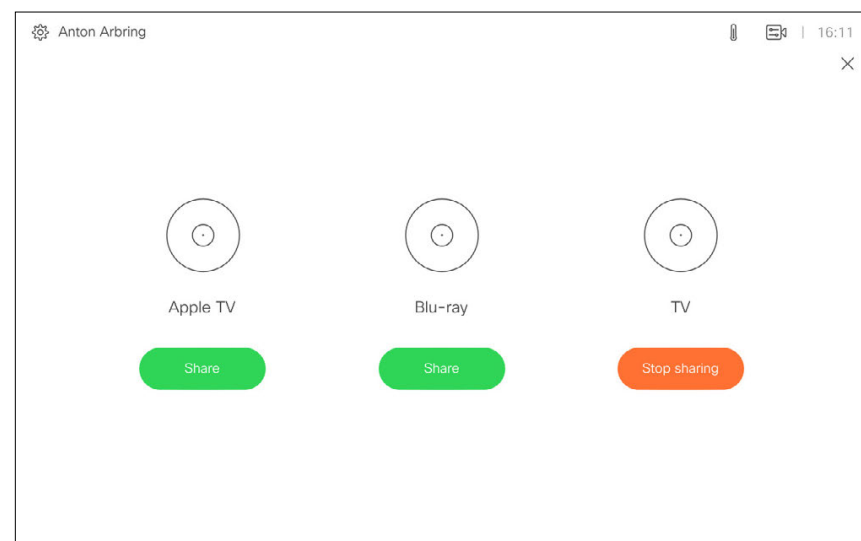

The video switch feature requires, similar to in-room controls, a third-party control system. The control system will use the Codec API to synchronize the source states between the video switch and your system's user interface using a set of API events and commands.

In order to make this work when the user selects a video source, the codec must be set to issue a corresponding event, which in turn shall cause the controller to send appropriate commands to the video switch and the codec.

This event will be issued only if the controller has registered to the codec upon connection, requesting the following from the codec:

```
xFeedback register Event/UserInterface/Presentation/
ExternalSource
```

The event issued will be as follows:

```
*e UserInterface Presentation ExternalSource Selected
SourceIdentifier: "XXXX"
```

Where "XXXX" is a unique string ID used to identify this source when selecting or setting state—see the following pages for more on this.

Furthermore, there are six commands available to control the system:

Add: Adds video source identifiers, including ID of connector, the name to appear on the screen, a unique string ID to identify a source when selecting or setting state, and what type of icon to display on the screen for each source.

List: Returns the current list of external sources.

Remove: Removes a source from the list.

RemoveAll: Removes all of the sources from the list.

Select: Selects a specific source.

State Set: Changes the state of a source.

These are all presented in detail on the following pages.

A simple example of a setup using the configuration shown above is provided in the article ["Video Switch Example"](#) on page 52.

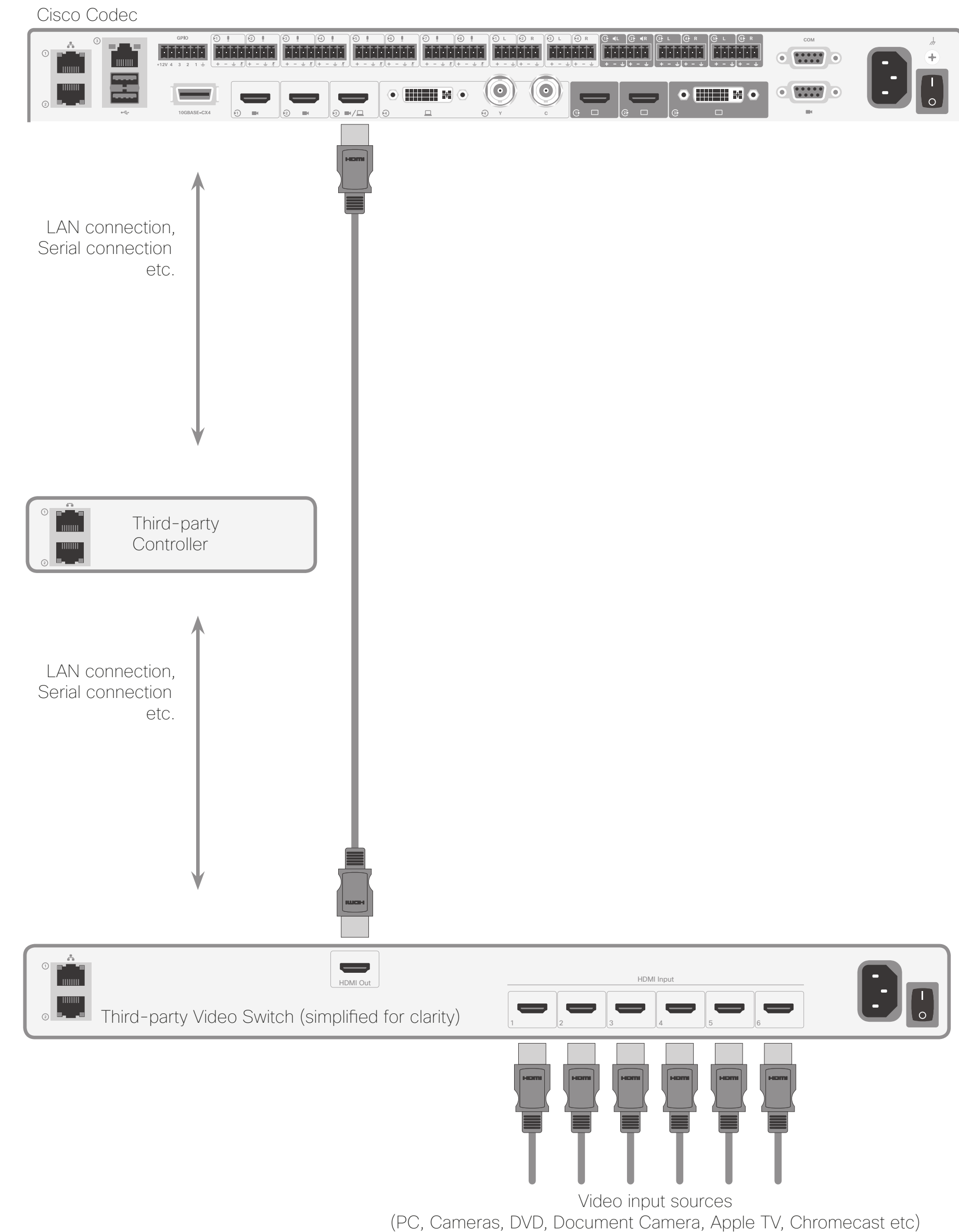

Command Details

UserInterface Presentation ExternalSource Add

This command establishes and defines an input source.

```
xcommand UserInterface Presentation ExternalSource Add ConnectorId:
  ConnectorId Name: Name SourceIdentifier: SourceIdentifier
  Type: Type
```

in which:

ConnectorId: The ID of the codec connector to which the external switch is connected

Name: Name displayed on the screen

SourceIdentifier: A unique string ID used to identify this source when selecting or setting state

Type: Decides what icon is displayed on the screen, choose between: <pc/camera/desktop/document_camera/mediaplayer/other/whiteboard>

Example:

```
xcommand UserInterface Presentation ExternalSource Add ConnectorId:
  3 Name: "Blu-ray"
  SourceIdentifier: bluray Type: mediaplayer
```

UserInterface Presentation ExternalSource List

This command returns the current list of external sources.

```
xcommand UserInterface Presentation ExternalSource List
```

UserInterface Presentation ExternalSource Remove

This command removes a source from the list.

```
xcommand UserInterface Presentation ExternalSource Remove
  SourceIdentifier: SourceIdentifier
```

in which:

SourceIdentifier is a unique string ID used to identify this source when selecting or setting state.

UserInterface Presentation ExternalSource RemoveAll

This command removes all sources from the list.

```
xcommand UserInterface Presentation ExternalSource RemoveAl
```

UserInterface Presentation ExternalSource Select

Starts to present the selected source if it is in ready state and has a valid ConnectorId. Also shows the item in sharetray as "Presenting".

```
xcommand UserInterface Presentation ExternalSource Select
  SourceIdentifier: SourceIdentifier
```

in which:

SourceIdentifier is a unique string ID used to identify this source when selecting or setting state.

UserInterface Presentation ExternalSource State Set

Used to change state of the source with SourceIdentifier.

```
xcommand UserInterface Presentation ExternalSource State Set
  SourceIdentifier: SourceIdentifier State: State [ErrorReason:
  ErrorReason]
```

in which:

SourceIdentifier: is a unique string ID used to identify this source when selecting or setting state

State: <Error/Hidden/NotReady/Ready> Ready is the only presentable state, hidden exists in the list but does not show in the sharetray.

ErrorReason: Optional. Displays in the share tray if the state is set to Error.

Part 3: Use of a Video Switch

Video Switch Example

A simple example of setup could be:

Controller sending:

```
xcommand UserInterface Presentation ExternalSource Add
  ConnectorId: 3 Name: "Blu-ray" SourceIdentifier: bluray Type:
  mediaPlayer

xcommand UserInterface Presentation ExternalSource Add
  ConnectorId: 3 Name: "Apple TV" SourceIdentifier: appletv Type:
  mediaPlayer

xcommand UserInterface Presentation ExternalSource Add
  ConnectorId: 3 Name: "TV" SourceIdentifier: tv Type:
  mediaPlayer
```

The default state is NotReady (Fig. 1)

So the next step for an integrator would be to set them to ready (Fig. 2).

```
xcommand UserInterface Presentation ExternalSource State Set
  State: Ready SourceIdentifier: bluray

xcommand UserInterface Presentation ExternalSource State Set
  State: Ready SourceIdentifier: appletv

xcommand UserInterface Presentation ExternalSource State Set
  State: Ready SourceIdentifier: tv
```

If one of the sources is selected on the video switch the controller should send a command accordingly:

```
xcommand UserInterface Presentation ExternalSource Select
  SourceIdentifier: tv
```

If the switch is connected on the chosen connector it will start to present (Fig. 3).

When a user selects another source, by clicking the other source item in the share tray, the codec will send the following event:

```
*e UserInterface Presentation ExternalSource Selected
  SourceIdentifier: "appletv"
```

The Controller should listen to this event and display the selected source.

Note! The presentation will not start if the below setting has been set to Manual:

```
xconfiguration Video Input Connector [x]
  PresentationSelection: <AutoShare, Desktop, Manual, OnConnect>
```

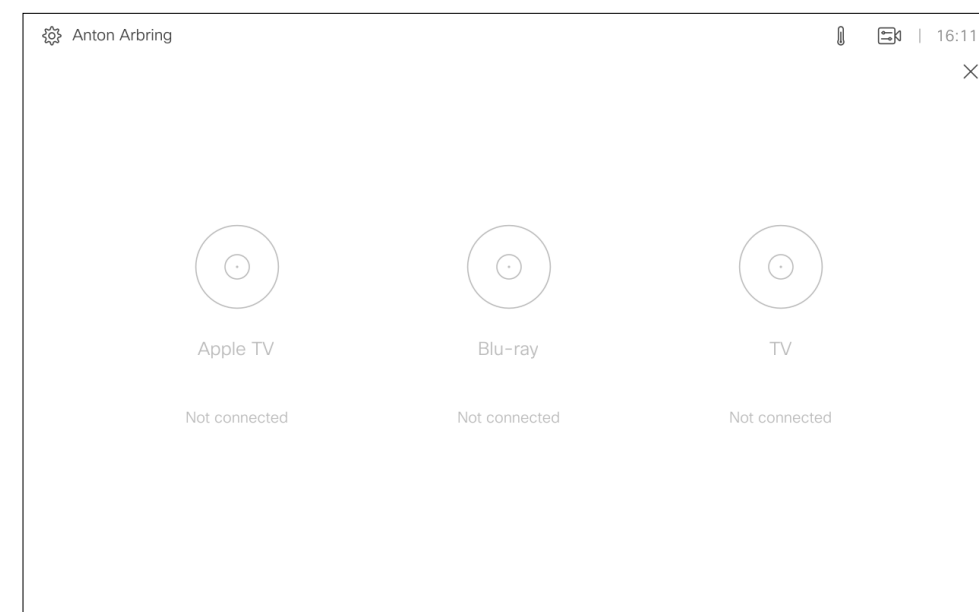

Fig. 1 Default state is NotReady.

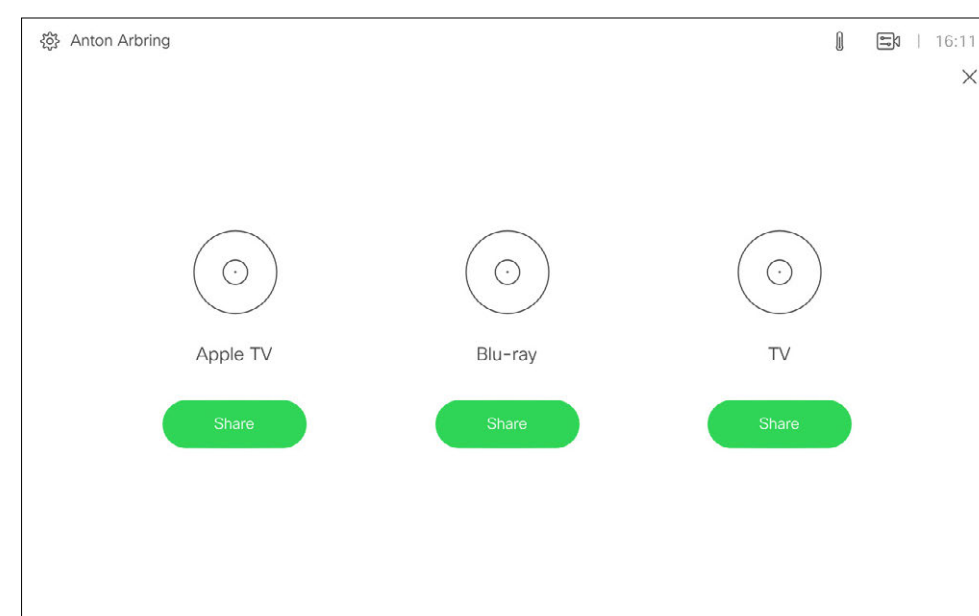

Fig. 2 When Input sources have been set to Ready.

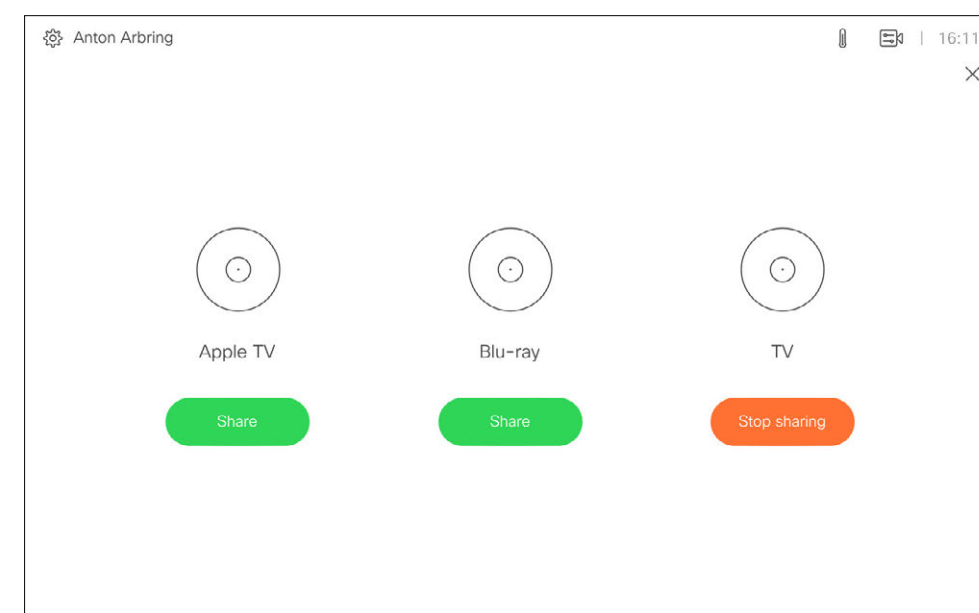

Fig. 3 If the switch is connected on the chosen connector it will start to present.

Part 4

Working with Macros



Creating Macros

Macros allow you to write snippets of JavaScript code that can automate parts of your video endpoint, thus creating custom behavior.

Note! The SX10 does not support macros.

Sign in to the video system's web interface with administrator credentials and navigate to **Integration > Macro Editor**.

The first time this is done on a codec, you will be asked whether to enable the use of macros on this codec.

You may later disable the use of macros from within the Macro Editor. This will not permanently disable macros from running. Every time the codec is restarted, the macros will be re-enabled automatically.

To disable automatic restart, you must use the `xConfiguration Macros Mode: Off`.

You may want to use this command in the event of unintended behavior by the system. In such cases you should always disable the macros before proceeding with your troubleshooting.

The Macro Framework has many benefits, as it allows integrators to:

- Tailor their deployments.
- Create their own “features” or “workarounds” to functionality Cisco is reluctant to provide in form of a new software feature.
- Automate scenarios/re-configurations.
- Create custom tests or monitoring.

With the Macros, in-room controls no longer need an external control system to activate local *functionality*.

However, performing local *actions* via the xAPI, such as to control other things like lights and blinds will still require a suitable third-party control system.

Examples of local *functionality* can be an In-Room Control panel for speed dialing or to trigger a “Room Reset” that puts all the configurations back to default (input sources, camera presets etc.).

Note! The Macro Framework is limited to local xAPI interaction. You cannot establish remote network connections to servers to push or receive data via the Macro Framework code.

Disclaimer: Cisco will support the Macro Framework itself only. Cisco will not support code that fails to compile or fails to work as the developer “intended”. It is entirely up to the person writing the code to ensure that the syntax is correct and that possessed coding skills are sufficient to write macros in JavaScript.

Please refer to public developer forums, the API Reference Guide of the product in question, as well as the Help section of the Macro editor. See also the following pages for more.

Part 4: Working with Macros The Macro Editor Panel

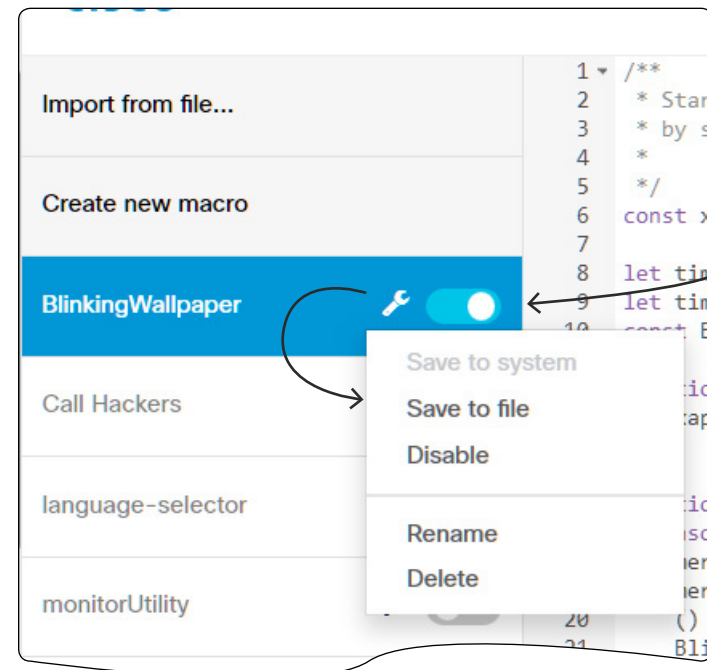

Activate or deactivate a macro.

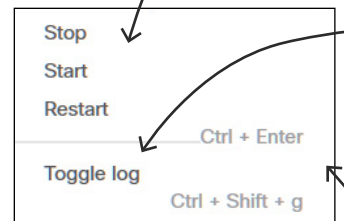

Use these to start, stop or restart the macros. Note that after a restart, macros will be re-enabled automatically, see text on the previous page for more on this.

Toggle log will hide / display the Log Console.

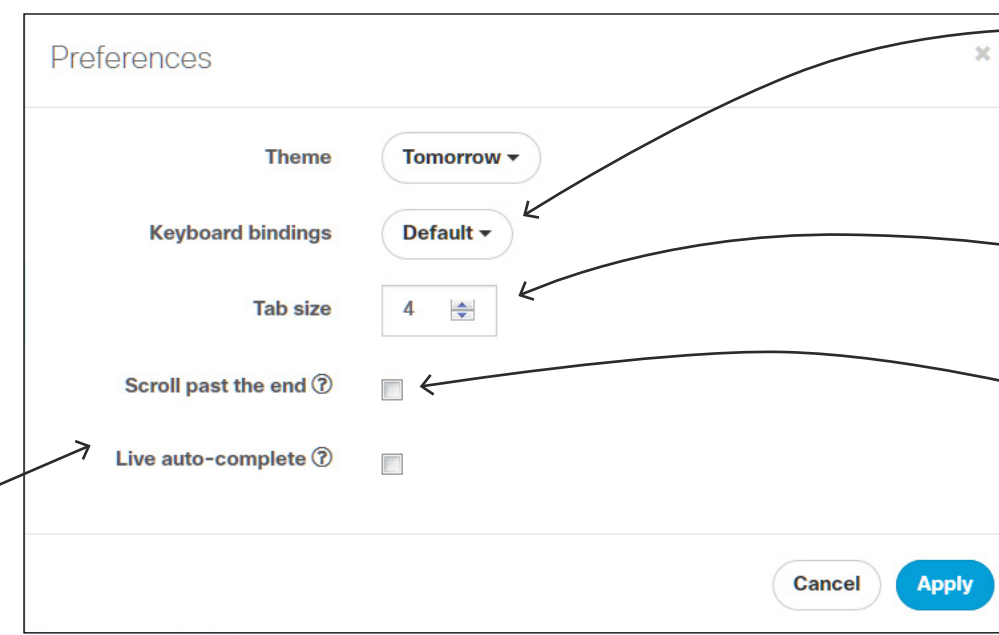

Defines which set of keyboard shortcuts to use, choose between **Vim** or **Emacs**.

Defines the width of a tab (in #spaces).

When checked, **Scroll past the end** keeps the bottom lines of your macro in the middle of your screen.

For any of the example macros you can click the **Load Example** in order to paste the code directly into the main editor window.

Note: You must be in an active editing session for this to work, click **Create new macro** from the left menu and then click **Load Example**.

Above shows where to start a new macro programming session from. You can either import existing code from a file (*.js), by clicking **Import from file...** or create a blank macro by clicking **Create new macro**.

By clicking **Create new macro**, the main editor window will be activated. You may now start coding.

The macro will be displayed in the list of macros.

Click the **Wrench** icon to gain access to available options, as shown above.

To change the name of a macro, you may also click its name, edit it, and then hit **Enter**.

Anytime a macro is saved, deleted or activated/deactivated, the whole runtime (and therefore all active macros) is restarted. Read more about runtime on the following page.

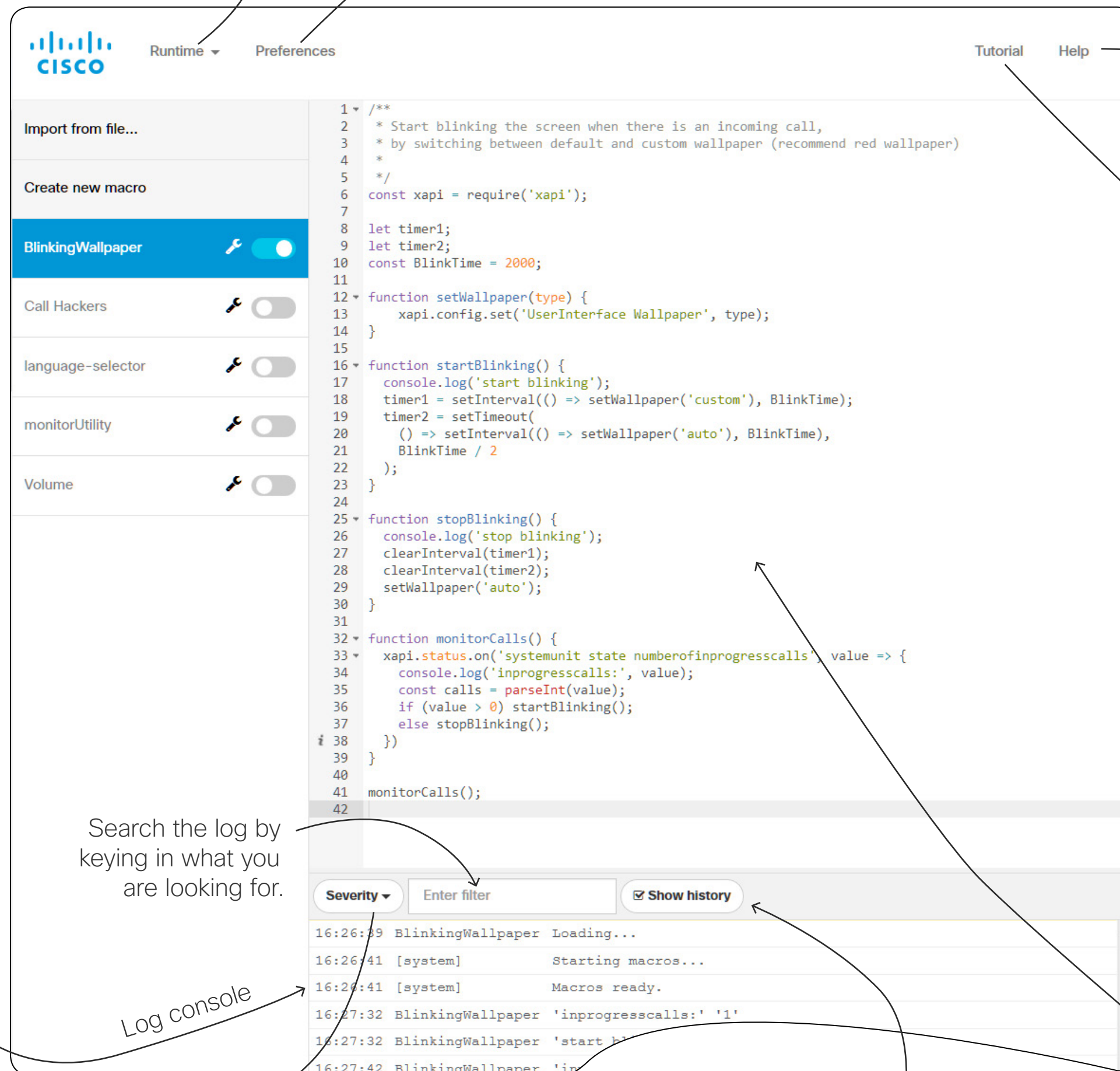

Introduction to macros
Macros tutorial

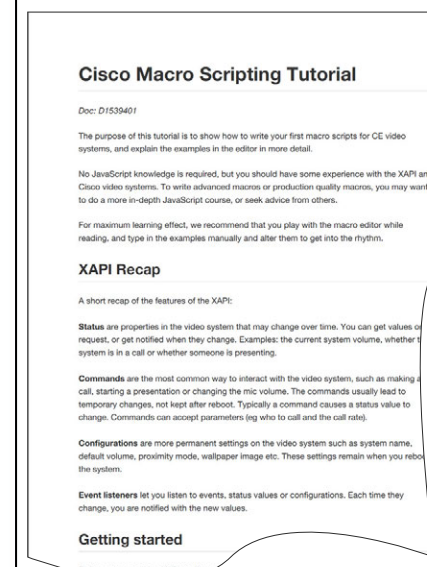

Clicking on the Tutorial will prompt you to download a PDF.

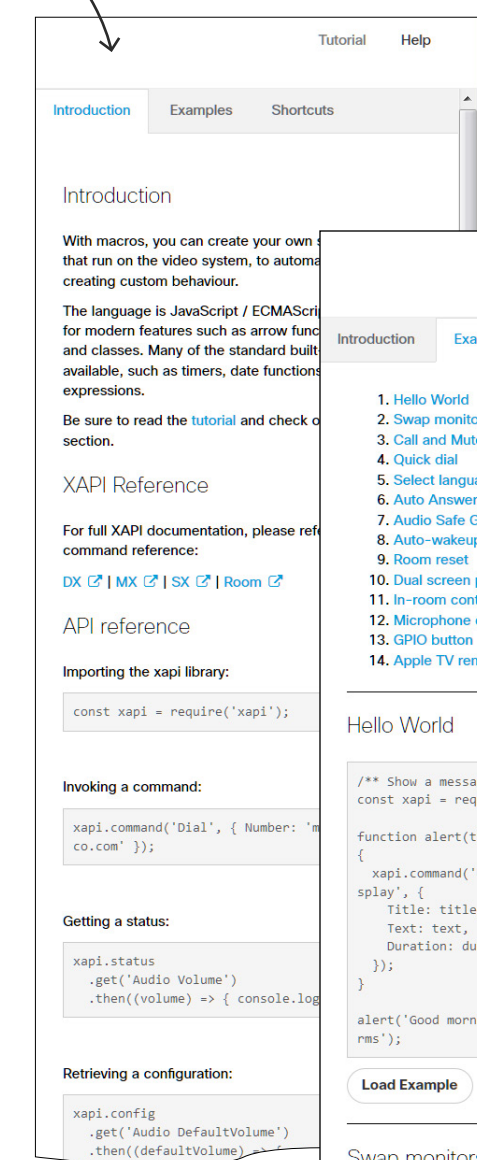

Keyboard shortcuts available.

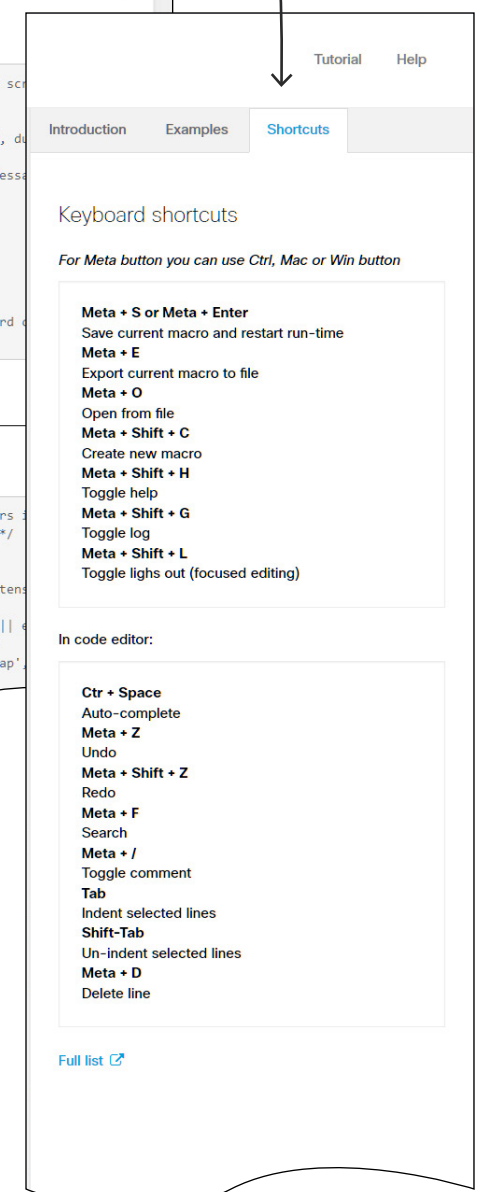

The purpose of the **Log Console** is to reveal what happens when you run the macro. Here you will see the actions of the runtime and whatever else you choose to print out to the console.

Much of what is displayed in the console log window is exported to the **macros.log** file in the log bundle of the endpoint.

This can be used to reveal errors and exceptions in the code. You can also log custom text by issuing:
`console.log('this is a log entry');`

Search the log by keying in what you are looking for.

Log console

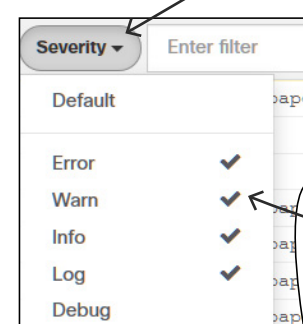

Make sure the type of errors and exceptions you want to be logged is checked here, otherwise they won't appear in the console log window.

Check **Show history** if you want to the log to cover the entire history and not just what has taken place since the last restart.

This is where you write the JavaScript code. Note that the JavaScript library may be perceived as somewhat limited in some areas. This has been done on purpose to prevent certain scenarios.

The editor automatically detects syntax errors, and will prevent you from saving the code if there are errors detected in the script. Hover over the error to see details.

Macros can alter the expected behavior of the system. If your macro is likely to surprise or confuse normal users, let them know with e.g. a notification on the video system screen.

We recommend that you never let macros depend on other macros. You can, of course, create several macros that listen to the same xapi values, e.g. the call state, as long as their actions are independent of each other.

Note that extensive use of macros may slow down codec performance due to heavy load.

Currently, macros cannot get or send data externally, e.g. to control lights in the room. For this you will need an external control system. However, it can be useful to combine macros and external systems, for example using a Crestron for light control at a low level, and then use macros to adjust in a more sophisticated way, such as adjusting the light depending on presentation status, call status etc.

Your macros may contain customized text to be displayed on the Touch10/DX. This text may alert users to observe the activation or deactivation of certain features as well as alert them to act in accordance with the message given, etc.

Such text can be purely informative, but it may also prompt the user to respond to it by keying in information. This information may, in turn, cause the video system to directly act upon it. See also [“Sending HTTP\(S\) Requests”^{REVISED}](#) on page 40.

About Macro Runtime

All the activated macros run in a single process on the video endpoint, called the macro runtime. It should be running by default, but you can choose to stop and start it manually from the editor. If you restart the video endpoint, the runtime will automatically start again if xconfiguration macros autostart is On.

If any macro becomes unresponsive (fails to respond within a few seconds due to e.g. an infinite loop), a safety mechanism will stop the runtime, thereby stopping all macros.

The runtime will then be automatically restarted after a few seconds. This will continue, but the time between restarts will increase every time the runtime is shut down. If this happens more than a certain number of times, this will cause a system diagnostic to be displayed to notify that the macros are having problems.

Learning Resources Available

If you want to learn about how to utilize the macros feature, may we recommend the following:

- Read through the *Introduction to Macros*, which can be found in the Help section of the Macro Editor.
- Read through the *Macros Tutorial*, which is also found in the Macro Editor. This tutorial is also available as a free download from cisco.com.
- The Macro Editor even contains several examples ready for use. All these examples may be loaded in to the editor and studied there, or they may be used as is in your configurations. They may, of course, also serve as basis for further refinement, if you so wish.

Disable Macros When Troubleshooting

If you experience unintended behavioral changes and you run macros on your system, make sure you deactivate the macros before proceeding with your troubleshooting.

Use xConfiguration Macros Mode: On/Off to do this.

The macro framework has its own log file called **macros.log**

The **macros.log** file contains much of what is printed in the Macro console. The macros can be configured to print output to the console and this will be stored in the log, so keep in mind that you can see custom log messages (which must have been created by the developer) in this file.

An *Introduction to Macros* can be found in the Help section of Macro Editor.

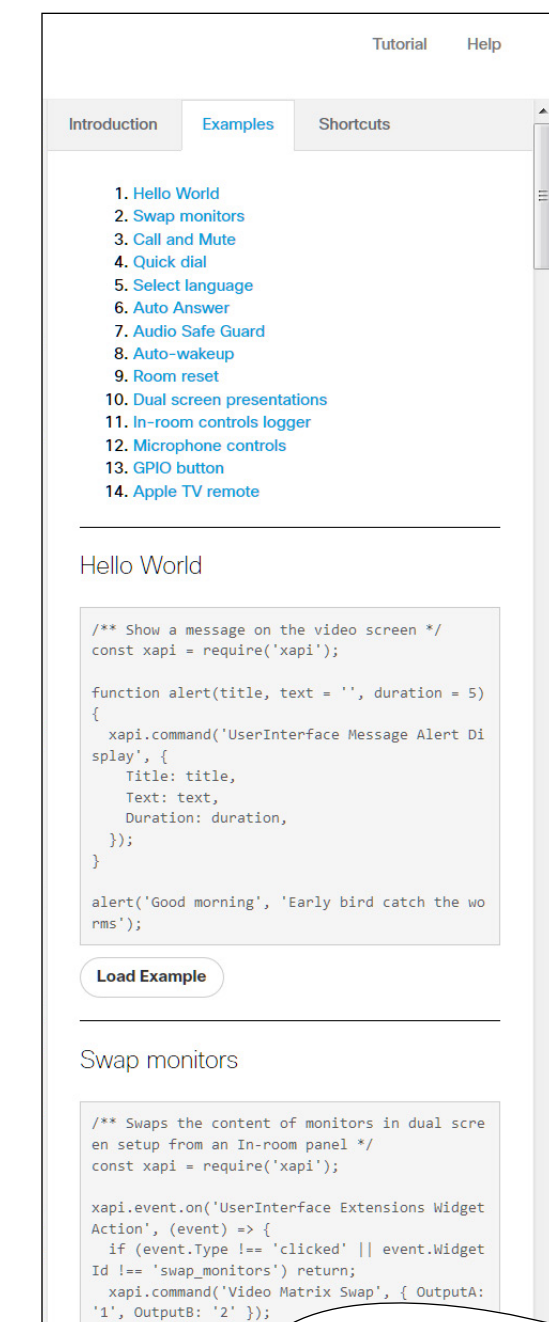
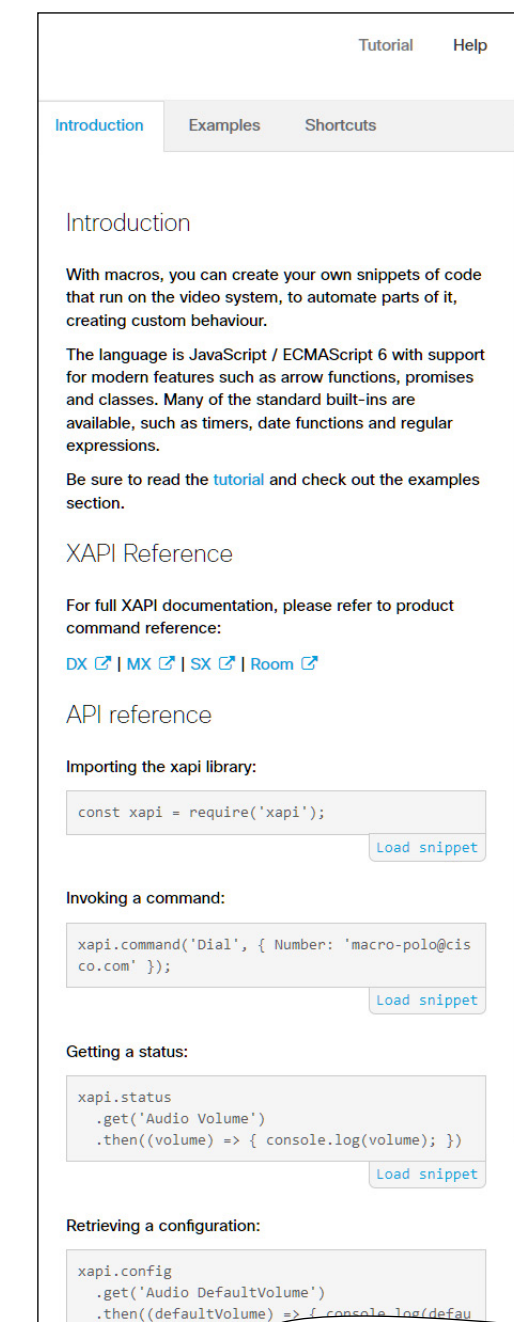

For any of the example macros you can click the **Load Example** in order to paste the code directly into the main editor window. See the previous page for more.

The *Tutorial* provides most of what you will need to know to start creating your own macros.

Note that clicking on the Tutorial will prompt you to download a PDF.

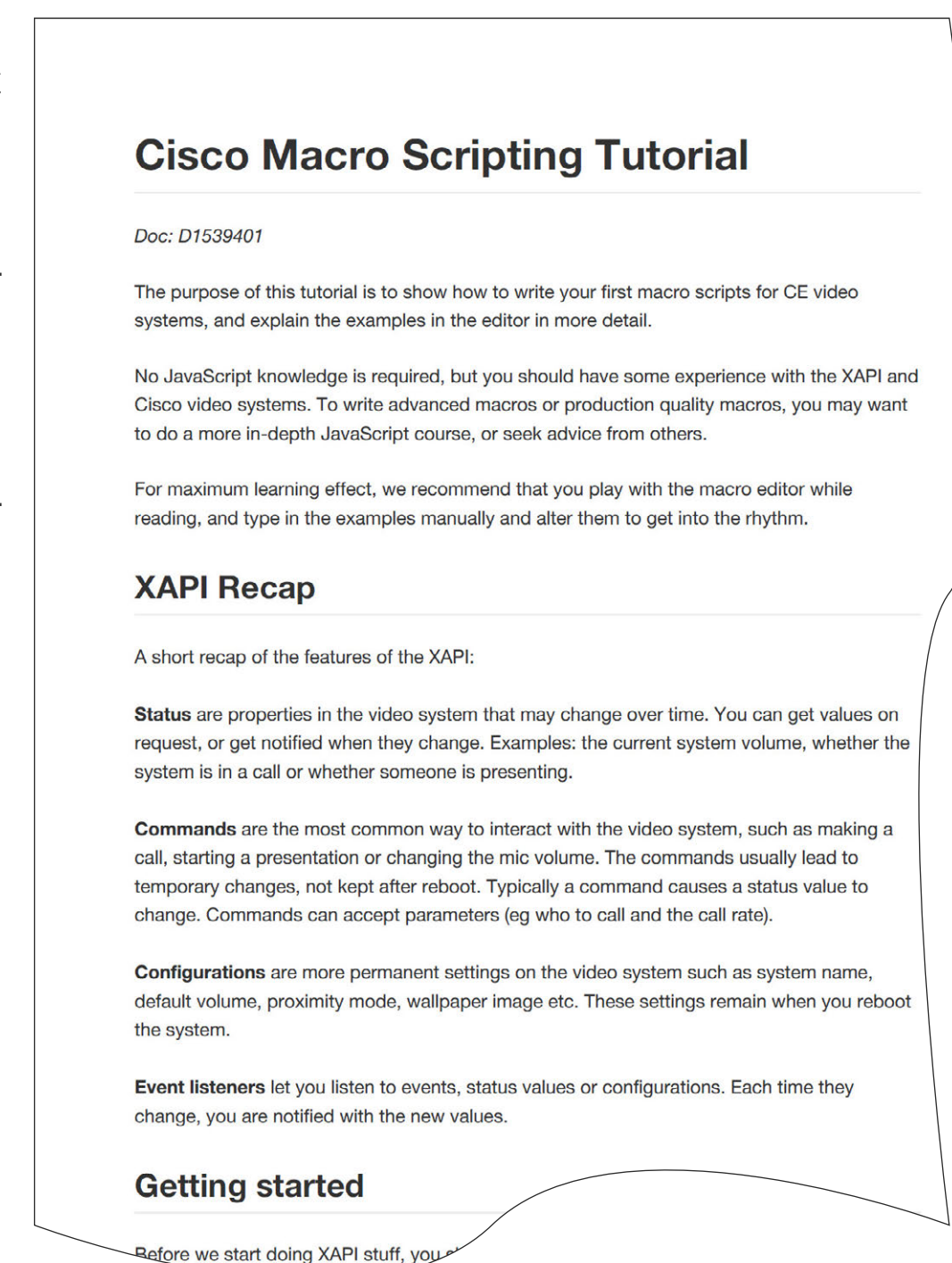

Part 5

Incorporating Third-party USB Control Devices



About the USB Control Device Functionality

Why This Feature?

What Is It?

This feature lets you use a third-party USB input device to control certain functions on, or behavior of, a video system. Examples of such devices could be a Bluetooth remote control (with a USB dongle) or a USB keyboard.

Note! To make this work you must define and implement any action the use of such input devices is meant to cause—there is no such as a library of actions readily available to pick actions from.

This feature is not meant to replace the Touch 10 or the DX user interface, but it may complement parts of their functionalities, wherever convenient.

Input Device Requirements

The input device must advertise itself as a USB keyboard. The term keyboard should not necessarily be understood literally here— a Bluetooth remote control with a USB dongle will do the trick.

Functional Overview

Pressing a button on the USB input device will generate an event in the API. Macros or third-party control devices can listen for such events and respond to them. This is similar to the In-Room Control buttons on the Touch 10 user interface. It is also possible to listen for the events via webhooks, directly in an SSH session.

You must implement the actions to be taken as response to these events. For example:

- Increase the volume of the video system when the Volume Up key is pressed.
- Put the video system in Standby Mode when the Sleep key is pressed.

Note! The support for third-party USB input devices is disabled by default. This means that you must explicitly enable it. Set the **Peripherals > InputDevice > Mode** to **On**

Pressing and releasing a button will generate a Pressed and a Released event, like this:

```
*e UserInterface InputDevice Key Action Key: <Name of key>
*e UserInterface InputDevice Key Action Code: <Id of key>
*e UserInterface InputDevice Key Action Type: Pressed
** end
*e UserInterface InputDevice Key Action Key: <Name of key>
*e UserInterface InputDevice Key Action Code: <Id of key>
```

```
*e UserInterface InputDevice Key Action Type: Released
** end
```

To listen for events, you must register feedback from the InputDevice events:

```
xFeedback Register /event/UserInterface/Inputdevice
** end
```

When the input device is detected by the video system, it shows up in the **UserInterface > Peripherals > ConnectedDevice** status. Note that the input device may be reported as multiple devices.

For a practical example, see the following page.

Examples of applications for this feature will typically be:

In classrooms and during lectures, a small remote control can be used to wake up systems from standby mode and select which input source to present.

Control of pan, tilt and zoom of a camera in situations where Touch 10 is an inconvenient alternative or not allowed to be used (for instance in operating rooms in hospitals combined with telemedicine).

Example on the Use of a Third-Party USB Input Device

This example shows how to use the keys of a third-party USB input device (in this case a remote control) to control the standby function, increase and decrease the volume, as well as to control the camera of a room or desk device.

The macro created will listen for relevant events, and carry out the associated actions using the API of the room or desk device.

Note: In the command examples below the text in normal font is entered by you, and the text in *italics* is the response received from the room device.

- 1 Sign in to the room or desk device on SSH. You need a local *admin user*.
- 2 Configure the device to allow the use of a 3rd party USB remote control.

```
xConfiguration Peripherals InputDevice Mode: On
** end

OK
```

Note: You can check if the configuration is On or Off by using this command:

```
xConfiguration Peripherals InputDevice Mode
*c xConfiguration Peripherals InputDevice Mode: On
** end

OK
```

- 3 Register for feedback, so that we are notified when the remote control buttons are pressed and released.

```
xFeedback Register /event/userinterface/inputdevice
** end

OK
```

Note: You can check which feedbacks the device is registered for, using this command:

```
xFeedback list
/event/userinterface/inputdevice
** end

OK
```

- 4 Press and release a button on the remote control to check that feedback registration works.

This generates two different events: **Pressed** and **Released**. If you press and hold a button you see the **Pressed** event until you release the button. Then the **Released** event is generated.

These are the events issued when pressing and releasing the Enter key:

```
*e UserInterface InputDevice Key Action Key: KEY_ENTER
*e UserInterface InputDevice Key Action Code: 28
*e UserInterface InputDevice Key Action Type: Pressed
** end
```

```
*e UserInterface InputDevice Key Action Key: KEY_ENTER
*e UserInterface InputDevice Key Action Code: 28
*e UserInterface InputDevice Key Action Type: Released
** end
```

- 5 Write a macro that listens for the relevant *InputDevice* events, and carries out the associated actions using the API of the device.

- a Bring the standby, volume up and volume down buttons to life.

When the macro sees an event containing **KEY_VOLUMEUP**, **KEY_VOLUMEDOWN**, or **KEY_SLEEP** it executes the related commands.

- b Create a camera control function for the arrow keys. We want to keep moving the camera as long as the button is pressed. When the button is released, the camera movement should stop.

When the macro sees an event containing **KEY_LEFT**, **KEY_RIGHT**, **KEY_UP**, or **KEY_DOWN**, it executes the related commands.

The parts related to the camera control function is highlighted with **bold** font in the code below.

```
const xapi = require('xapi');

function com(command, args='') {
  xapi.command(command, args);
  log(command + ' ' + JSON.stringify(args));
}

function log(event) {
  console.log(event);
}

function notify(message) {
  xapi.command('UserInterface Message TextLine Display', {
    Text: message,
    duration: 3
  });
}

function cameraControl(motor, direction, cameraId='1') {
  com('Camera Ramp', { 'CameraId': cameraId,
    [motor]: direction
  });
}

function init() {
  let standbyState;
  xapi.status.get('Standby').then((state) => {standbyState = state.State
=== 'Off' ? false : true; });
  xapi.status.on('Standby', state => {
    standbyState = state.State === 'Off' ? false : true;
  });
}
```

```
xapi.event.on('UserInterface InputDevice Key Action', press => {
  if (press.Type == "Pressed") {
    switch (press.Key) {
      case "KEY_LEFT":
        cameraControl('Pan', 'Left');
        break;
      case "KEY_RIGHT":
        cameraControl('Pan', 'Right');
        break;
      case "KEY_UP":
        cameraControl('Tilt', 'Up');
        break;
      case "KEY_DOWN":
        cameraControl('Tilt', 'Down');
        break;
      default:
        break;
    }
  } else if (press.Type == "Released") {
    switch (press.Key) {
      case "KEY_LEFT":
        cameraControl('Pan', 'Stop');
        break;
      case "KEY_RIGHT":
        cameraControl('Pan', 'Stop');
        break;
      case "KEY_UP":
        cameraControl('Tilt', 'Stop');
        break;
      case "KEY_DOWN":
        cameraControl('Tilt', 'Stop');
        break;
      case 'KEY_VOLUMEUP':
        com('Audio Volume Increase');
        break;
      case 'KEY_VOLUMEDOWN':
        com('Audio Volume Decrease');
        break;
      case 'KEY_SLEEP':
        com(standbyState ? 'Standby Deactivate' : 'Standby Activate');
        break;
      default:
        break;
    }
  }
});
}
```

Part 6 Audio Console



Customizing the Audio Connections

The Audio Console utility lets you define how audio inputs and outputs should be connected together, using simple drag and drop.

The Audio Console is available for systems using **SX80** and **Codec Pro**, including video systems with those codecs built-in.

The Audio Console can be found under Setup in the Web interface of your video system.

You start by defining logical input and output groups. The physical inputs and outputs are then assigned to those logical inputs and outputs.

New logical input and output groups may be added at all times. Likewise, you may remove logical modules at all times.

Changes applied to the settings are immediately put into effect. In this version saving has been automated, no need to worry!

The logical input and output groups can be given names defined by you.

A physical input, e.g. a microphone, can be assigned to more than one input. This comes in handy when working with local reinforcement, typically using a video system in lecture halls where the local audience also needs to hear what is being said through the microphone.

The Audio Console setup lets you utilize Echo Control on the part of the microphone signal that is sent to the far end, but at the same time omitting it for the part used locally (by assigning that microphone to more than one logical group).

You may also apply noise reduction and equalizer settings to the microphone signal.

A physical output cannot be assigned to more than a single logical output group.

In the Codec Pro, a Microphone input is a Line input with Phantom Feeding activated. This will give you more degrees of freedom since you will not be limited to a fixed number of microphone inputs and a fixed number of line inputs.

Using Audio Return Channels

HDMI offers, under certain circumstances, the ability to transmit audio in either direction. When audio is sent in reverse, this is referred to as an Audio Return Channel (ARC). The Codec Pro supports this.

Consider the below configuration, showing a Cisco QuadCam (top), a monitor (middle), and a Codec Pro (bottom) connected via HDMI. The QuadCam will act as both camera and soundbar in this setting.

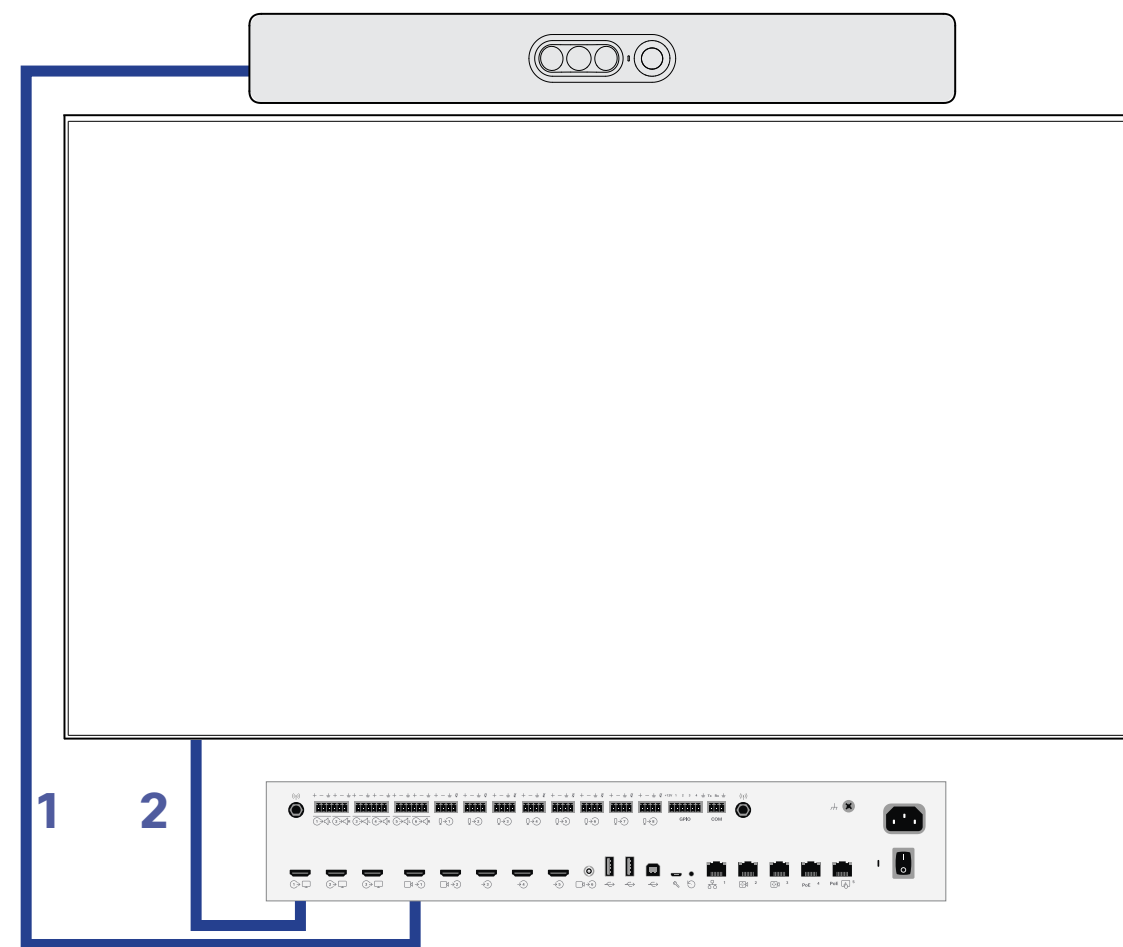

During normal use, the HDMI1 is used to provide the Codec Pro with video from the cameras of the QuadCam unit and the audio return channel of the same will be used to route the audio from the Codec Pro to the loudspeakers of the QuadCam.

However, if you want to use the setup as just a TV with a soundbar, the system will send audio from the monitor to the Codec Pro through HDMI out 1 (ARC) of Codec Pro and the Codec Pro will send that audio further to the QuadCam through HDMI1 in (ARC).

In order to be able to do this, the monitor must be CEC+ARC enabled. If your setup makes use of 4k video, make sure the monitor supports CEC+ARC in 4k format.

The Audio Console Panel

The Audio Console can be found under **Setup** in the Web interface of your video system.

The pool of physical Input connectors available.

The physical Input connectors are assigned to logical Input groups. These logical Input groups are created by you.

The name of a logical group is specified by you when clicking on **New input group**.

A given physical Input connector may be assigned to more than one logical group. Use Drag and Drop.

To remove a group or a member of a group hover the mouse over the group or member. An **X** will appear. Click on this to remove the item.

A member of a logical group may be expanded to gain access to setup details:

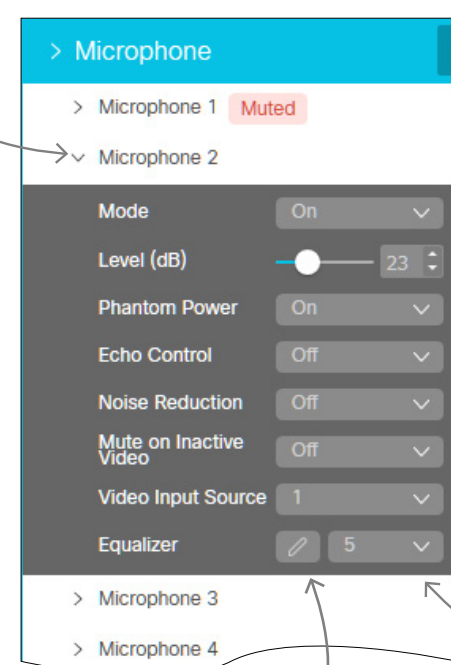

Gain access to the equalizer setup.

Use this feature in scenarios with e.g. a presenter's microphone. This mic will be muted unless the associated camera (the one filming the presenter) actually sends video, provided that you have set up a camera/mic combination this way.

Equalizer lets you choose among up to 8 predefined equalizer settings (or none, i.e. **Off**). This version of the Audio Console offers a graphical tool to set up the equalizer, see the next page for more on this.

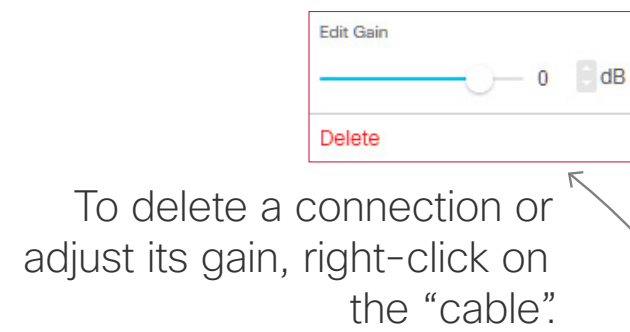

To delete a connection or adjust its gain, right-click on the "cable".

For the Codec Pro and the Room 70 G2 there is an automatic mode available. This mode will create a preset of connections based on connected devices detected. You may then modify this to your liking.

Gain access to the equalizer setup.

This is the pool of physical Output connectors not yet used. They are therefore considered inactive.

The logical Output groups are similar to the logical Input groups, but a physical Output cannot be assigned to more than one logical Output group.

Click **here** and drag over **here** to establish a connection between an Input and an Output.

Expand the Logical group rather than the individual members of the Logical group when using it for local reinforcement.

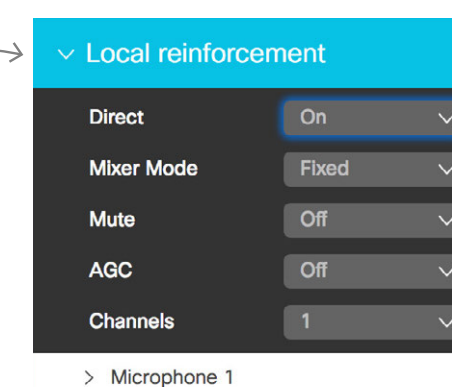

For local reinforcement scenarios, set microphones to **Direct**, see text below.

A few things to note:

The Codec Pro offers Audio Return Channels (ARC) as additional choices (see the previous page for more on this).

In the Codec Pro, a **Microphone input** is a **Line input** with **Phantom Feeding** activated. If a **Microphone input** is converted to **Line input**, the **Phantom Feeding** will be switched off, any mute will be ignored and the **Gain** value space will be reduced from 0-70 dB to 0-24 dB.

In local reinforcement scenarios, make sure you set the **Microphone(s)** to **Direct** to bypass extra processing like Echo Control. This will minimize latency and also serve to avoid that the Master volume control also affects the volume of the local presenter.

Expand the logical group to gain access to this, as shown above.

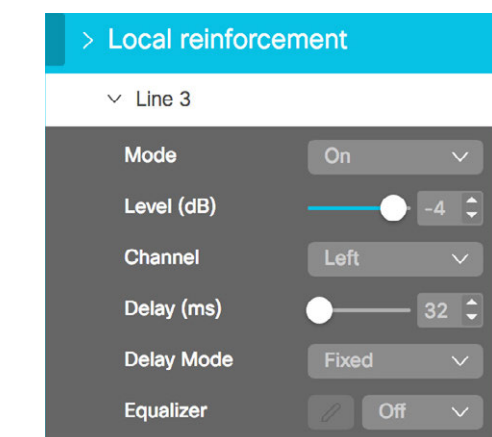

We recommend that you set **Delay Mode** to **Fixed** to avoid potential delay caused by external screens.

Setting Up the Equalizer

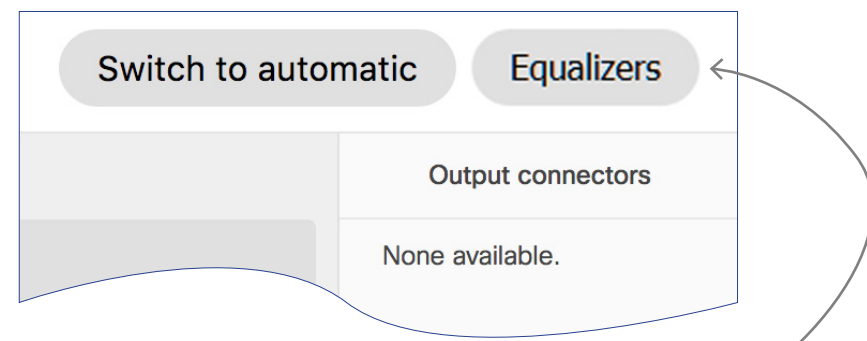

Gain access to the equalizer from **here** or **here**.

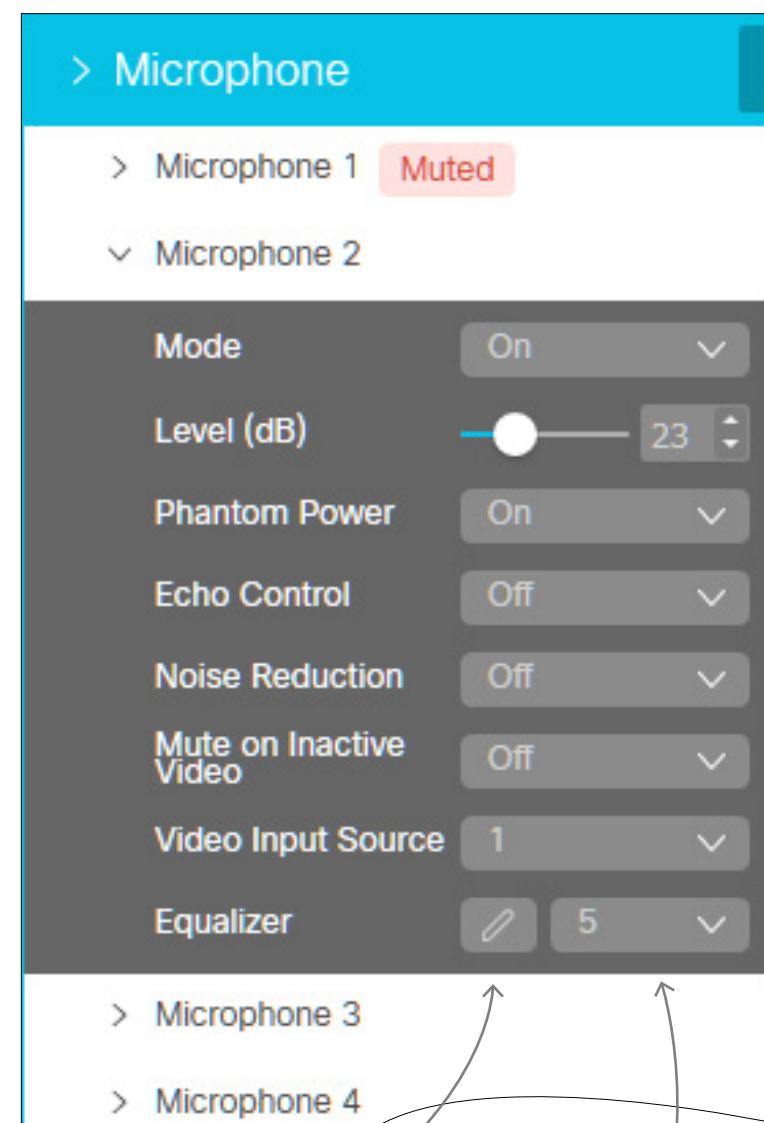

Here you define which of the 8 equalizer settings to apply (No. 5 in this example).

There are 8 user-definable parametric equalizer settings available.

A setting consists of up to 6 sections, each of which has its own filter type, gain, center/crossover frequency and Q value.

Each section is shown with its own color, while the white line shows the combined frequency response of the equalizer.

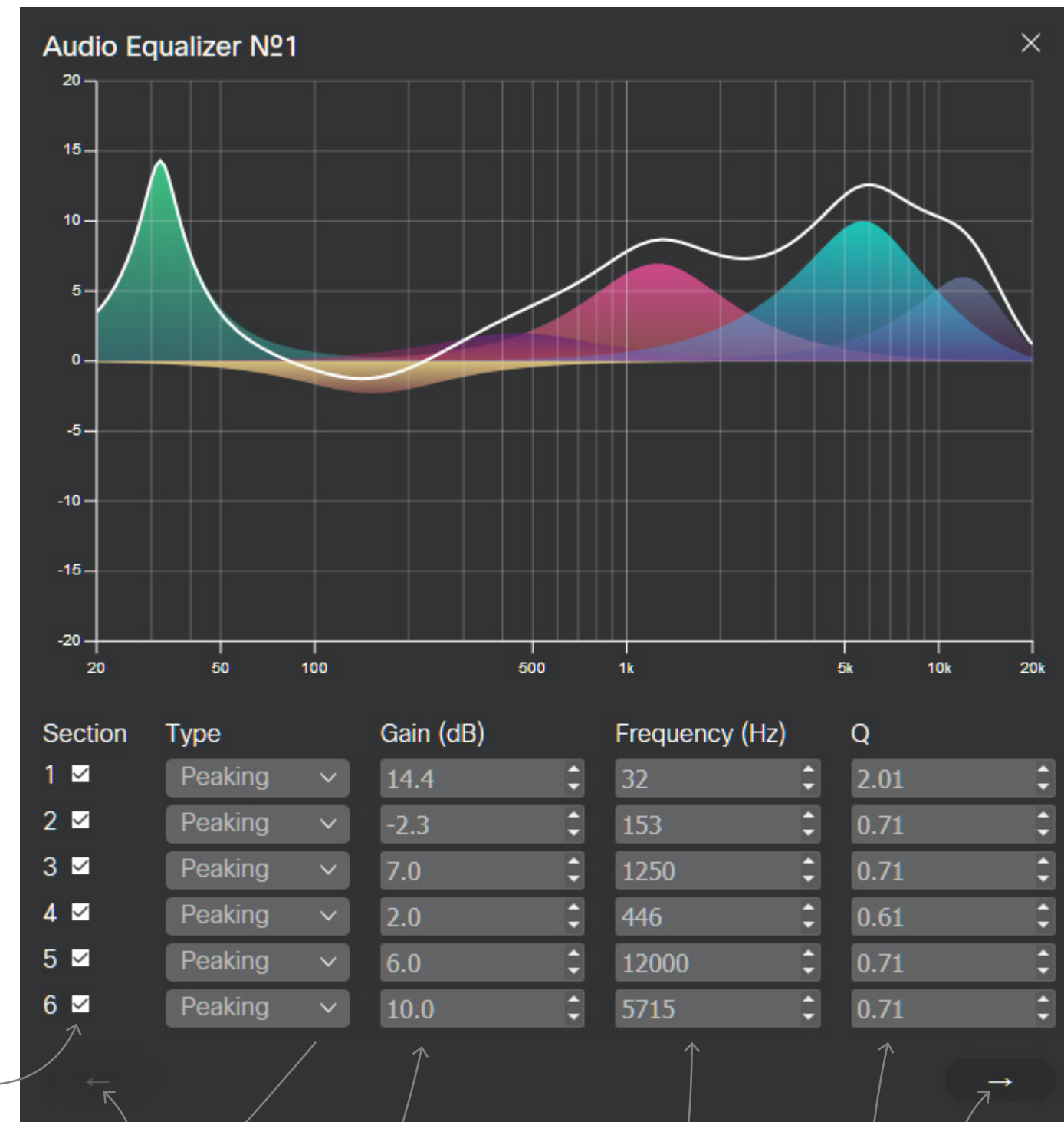

The effect of altering any of the parameters will immediately become visible in the graph.

Your settings are saved automatically, no need to click a **Save** button anymore!

To activate or deactivate a filter section, click **here**.

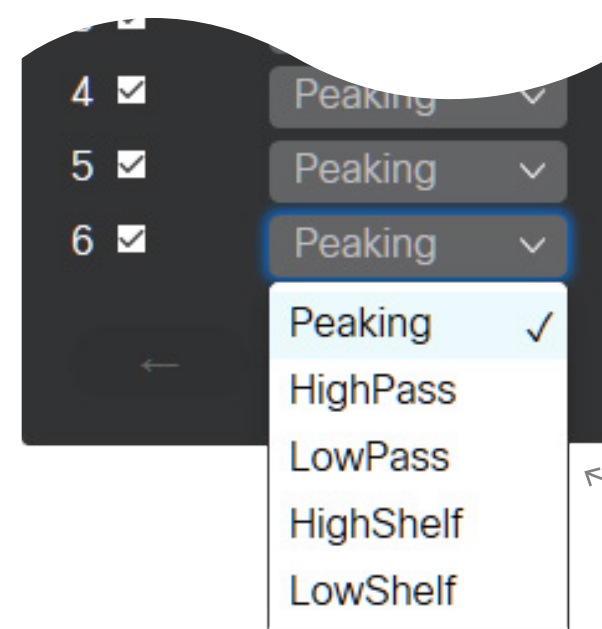

The filter types available

Previous setting (if applicable)

Next setting (if applicable)

Value space for the Gain setting is 0 dB ±20 dB.

Value space for Frequency is 20-20000 Hz.

Value space for Q is 0.1-10.0.

Cisco contacts

On our web site you will find an overview of the worldwide Cisco contacts.

Go to: <http://www.cisco.com/go/offices>

Corporate Headquarters
Cisco Systems, Inc.
170 West Tasman Dr.
San Jose, CA 95134 USA

Intellectual property rights

THE SPECIFICATIONS AND INFORMATION REGARDING THE PRODUCTS IN THIS MANUAL ARE SUBJECT TO CHANGE WITHOUT NOTICE. ALL STATEMENTS, INFORMATION, AND RECOMMENDATIONS IN THIS MANUAL ARE BELIEVED TO BE ACCURATE BUT ARE PRESENTED WITHOUT WARRANTY OF ANY KIND, EXPRESS OR IMPLIED. USERS MUST TAKE FULL RESPONSIBILITY FOR THEIR APPLICATION OF ANY PRODUCTS.

THE SOFTWARE LICENSE AND LIMITED WARRANTY FOR THE ACCOMPANYING PRODUCT ARE SET FORTH IN THE INFORMATION PACKET THAT SHIPPED WITH THE PRODUCT AND ARE INCORPORATED HEREIN BY THIS REFERENCE. IF YOU ARE UNABLE TO LOCATE THE SOFTWARE LICENSE OR LIMITED WARRANTY, CONTACT YOUR CISCO REPRESENTATIVE FOR A COPY.

The Cisco implementation of TCP header compression is an adaptation of a program developed by the University of California, Berkeley (UCB) as part of UCB's public domain version of the UNIX operating system. All rights reserved. Copyright © 1981, Regents of the University of California.

NOTWITHSTANDING ANY OTHER WARRANTY HEREIN, ALL DOCUMENT FILES AND SOFTWARE OF THESE SUPPLIERS ARE PROVIDED "AS IS" WITH ALL FAULTS. CISCO AND THE ABOVE-NAMED SUPPLIERS DISCLAIM ALL WARRANTIES, EXPRESSED OR IMPLIED, INCLUDING, WITHOUT LIMITATION, THOSE OF MERCHANTABILITY, FITNESS FOR A PARTICULAR PURPOSE AND NONINFRINGEMENT OR ARISING FROM A COURSE OF DEALING, USAGE, OR TRADE PRACTICE.

IN NO EVENT SHALL CISCO OR ITS SUPPLIERS BE LIABLE FOR ANY INDIRECT, SPECIAL, CONSEQUENTIAL, OR INCIDENTAL DAMAGES, INCLUDING, WITHOUT LIMITATION, LOST PROFITS OR LOSS OR DAMAGE TO DATA ARISING OUT OF THE USE OR INABILITY TO USE THIS MANUAL, EVEN IF CISCO OR ITS SUPPLIERS HAVE BEEN ADVISED OF THE POSSIBILITY OF SUCH DAMAGES.

Any Internet Protocol (IP) addresses and phone numbers used in this document are not intended to be actual addresses and phone numbers. Any examples, command display output, network topology diagrams, and other figures included in the document are shown for illustrative purposes only. Any use of actual IP addresses or phone numbers in illustrative content is unintentional and coincidental.

All printed copies and duplicate soft copies are considered un-Controlled copies and the original on-line version should be referred to for latest version.

Cisco has more than 200 offices worldwide. Addresses, phone numbers, and fax numbers are listed on the Cisco website at www.cisco.com/go/offices.

Cisco and the Cisco logo are trademarks or registered trademarks of Cisco and/or its affiliates in the U.S. and other countries. To view a list of Cisco trademarks, go to this URL: www.cisco.com/go/trademarks. Third-party trademarks mentioned are the property of their respective owners. The use of the word partner does not imply a partnership relationship between Cisco and any other company. (1110R)