

Upon Improving the Prediction of the Flow Rate of Sonic Pump

Ivan A. Loukanov *, Jacek Uziak **

*(Department of Mechanical Engineering, University of Botswana, Botswana)

** *(Department of Mechanical Engineering, University of Botswana, Botswana)

ABSTRACT

The aim of this paper is to develop an improved equation for the prediction of the flow rate of a sonic pump. Based on the pump equations of motion and the previously derived equation for the flow rate a new expression for the water column (WC) relative displacement is obtained accounting for the valve head losses, valve submersion depth and the depth of pumping. The earlier version of the flow rate equation is then modified with the new relative displacement of the WC to obtain an improved equation for the flow rate. In addition to that the proposed equation is customized to account for the head losses in the pipes. The analysis revealed that the new equation predicts the flow rate much better than the old one and its predictions match closely the experimentally determined flow rates discharged by a model low frequency sonic pump.

Keywords - sonic pumps, water column motion, poppet valve

I. INTRODUCTION

Since the invention of the sonic pump by Bodine [1] it was widely used in the oil industry of the USA, France, Italy, UK and Russia for many decades primarily for pumping crude oil from deep wells. Some attempts were made in the past to utilize sonic pumps for pumping ground water from deep boreholes of small diameters [2, 3] and even today these pumps are successfully used for pumping ground water from medium depth boreholes for agricultural applications [4, 5, 6]. One of the most challenging problems with these pumps is to develop an equation for proper prediction of the flow rate. The problem is that the parameters involved in the pumping process of the sonic pumps, known also as inertia pumps, are numerous having very complicated interactions. First attempt was made by [2] who proposed the following simple equation for the flow rate of an inertia pump,

$$Q = L.A \frac{\omega}{2\pi} \quad (1)$$

where, L – is the distance between the valve seat and the lower end of the water column (WC) in the pipe when it is in the highest position, A – is the pipe cross sectional area, and $\omega/2\pi$ is the frequency of pipe oscillations. Later Usakovskii in

his monograph on inertia pumps suggested the following empirical equation for the flow rate [3],

$$Q = cX \sqrt{\omega - \sqrt{\frac{g}{X}}} \quad (2)$$

where, c is a coefficient accounting for the pump design and the depth of pumping; X is the amplitude of the pipe oscillations and g - the gravitational acceleration.

Later an attempt is made by Loukanov [7] based on the approach suggested by Usakovskii [2]. The proposed equation is applicable for a low frequency (up to 20 Hz) sonic (inertial) pump and is given by the expression,

$$Q_{\text{with } g}^{\text{Theoretical}} = 250\pi d_{in}^2 x_{rel} n \text{ [l/min]} \quad (3)$$

where, x_{rel} is the relative distance between the valve seat and the bottom end of the WC when the latter is in its highest position with respect to the valve and is given by,

$$x_{rel} = \frac{[\omega X_{\max} \cos(\omega t_s)]^2}{2g} + \frac{g}{\omega^2} - X_{\max} \sin[\omega(t_s + t_1)] \quad (3a)$$

Equations (3) and (3a) are derived based on the assumption that the WC motion in the pipe is controlled by the gravitational acceleration only, $g = 9.81 \text{ m/s}^2$ [7].

Unfortunately the predicted flow rate by (3) appears to be on the high side, because it does not account for the head losses in the valve and the pipe system, and does not consider the effect of the depth of pumping and the valve submersion depth under the water level in the well.

In this regard an effort is made to improve the prediction of (3) taking into account the major pump and valve design parameters as well as the installation parameters of the pump [8].

Therefore the aim of this paper is to derive an equation predicting closely the flow rate of a sonic pump taking into consideration the most important pump and valve design parameters, friction losses in the pipe system and compare the predicted flow rates with that provided by (3) and the experimental results obtained from a model low frequency sonic pump.

II. MATERIAL AND METHODS

In the following analysis the dynamic model proposed by Loukanov [7] is considered in order to account for the effects of valve head losses, valve submersion depth under the water level in the

well, the depth of pumping and the friction losses in the pipe system on the flow rate of a sonic pump. Fig. 1 shows the dynamic model of a sonic pump when furnished with a single spring-loaded poppet valve. The model is one degree-of-freedom oscillating system and for the ease of the analysis it is assumed that both the pipe and the water column (WC) in the pipe are solid bodies. As a result of that the compressibility of WC and the elastic properties of the pipes are ignored. Due to the fact that the pipes, the valve and the shaker are connected together they undergo the same displacement, velocity and acceleration. The total mass of the oscillating system - M consists of masses of the shaker, pipes, foot valve and that of the WC in the pipes. In Fig. 1 $x(t)$ denotes the absolute displacement of the oscillating system of mass M , [kg], H is the depth of pumping, [m], and h_s is the depth of valve submersion under the water level in the well, [m].

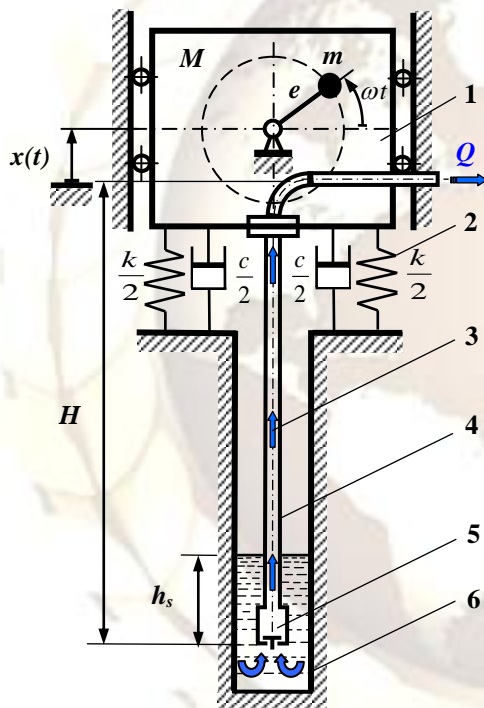

Figure 1. Dynamic model of sonic pump: 1 - mechanical shaker with unbalance me , rotating at an angular speed n [rev/min] or ω [rad/s], 2 - spring suspension system of stiffness k [N/m] and damping c [N.s/m], 3 - WC enclosed in the pipes, 4 - A series of connected pipes, 5 - one way spring-loaded poppet valve, 6 - borehole and the aquifer. The equations governing the resonance vibrations of the pipe (valve) for a period of oscillation are,
 $x_p(t) = X_{\max} \sin \omega t$,
 $v_p(t) = \omega X_{\max} \cos \omega t = V_{\max} \cos \omega t$ (4)
 $a_p(t) = -\omega^2 X_{\max} \sin \omega t = -a_{\max} \sin \omega t$
 where,

ω is the angular frequency of the system, [rad/s]

$$X_{\max} = \frac{me}{2M\zeta\sqrt{1-\zeta^2}}, \text{ [m]} \quad (4a)$$

is the resonance amplitude of the pipe (valve) and,

$$\zeta = \frac{\delta}{\sqrt{4\pi^2 + \delta^2}} \quad (4b)$$

is the damping factor of the oscillating system obtained through the logarithmic decrement of the free damped vibrations of the system [7].

The equations governing the absolute and independent motion of the WC taking place inside the pipe after separating from the valve are found to be,

$$\begin{aligned} x_{wc}(t) &= -\frac{g_1 t^2}{2} + (V_{\max} \cos \omega t_s) t + \frac{g}{\omega^2} \\ v_{wc}(t) &= -g_1 t + (V_{\max} \cos \omega t_s) \\ a_{wc}(t) &= -g_1 \end{aligned} \quad (5)$$

The parameters involved in (5) are as follows:

$$g_1 = g \left(1 + \frac{h_v - h_s}{H} \right), \text{ [m/s}^2\text{]} \quad (6)$$

is the WC retardation during the motion in the pipe, being mainly dependent upon the valve head losses h_v , valve submersion depth h_s , and the depth of pumping H . Where g is the gravitational acceleration $g=9.806 \text{ m/s}^2$ as mentioned above.

The parameter t_s involved in (5) is the time taken by the pipe (valve) to move from equilibrium position to the point of separation when motion takes place in Phase 1 [7],

$$t_s = \frac{1}{\omega} \sin^{-1} \left(\frac{g}{a_{\max}} \right), \text{ [s]} \quad (7)$$

The modification of (3) requires determining a new expression for the relative distance between the bottom end of the WC, when it is in the top dead position (TDP), and the valve seat, further designated as x_{rel}^{wc} . It is obtained from (5), and hence accounts for the parameters involved in (6). After substituting the new expression for x_{rel}^{wc} in (3) the equation for the improved flow rate of the pump is obtained.

The new equation predicting the flow rate of a sonic pump is then presented in the following form as,

$$Q_{\text{with } g_1}^{\text{Theoretical}} = 250\pi d_{in}^2 x_{rel}^{wc} n, \text{ [l/min]} \quad (8)$$

where,

d_{in} - is the valve inlet diameter, assumed to be equal to the pipe internal diameter, [m];

x_{rel}^{wc} - is the relative distance between the valve seat and the bottom end of WC when the WC is in the top dead position [m], and

n - is the shaker speed of rotation, [rev/min].

The proposed expression for the WC relative displacement is based on (3a) but the terms involved

are obtained from (5) hence accounting for the WC retardation given by (6), where $g_l \neq g$. This is contrary to (3a) which is derived on the assumption that WC retardation is due to the gravitational acceleration $a_{wc} = -g$ only.

In this regard the new WC relative displacement is defined as per Loukanov [7] in the form,

$$x_{rel}^{wc} = h_{max} - x_p(t_s + t_1) \quad [m] \quad (9)$$

Now the WC maximum height h_{max} is obtained from (5) for the following end conditions being used:

At $t = t_1$, $V_{wc}(t_1) = 0$ and $x_{wc}(t_1) = h_{max}$

Upon substitution in the first expression of (5) and rearranging terms yields,

$$h_{max} = x_{wc}(t_1) = \frac{[\omega X_{max} \cos(\omega t_s)]^2}{2g_1} + \frac{g}{\omega^2}, \quad [m] \quad (10)$$

where,

h_{max} is measured from the equilibrium position of the oscillating system to the top dead position (TDP) of the WC, the retardation g_l of the WC is given by (6) and the separating time t_s by (7).

The time variable t_l used in deriving (10) is obtained from the second term of (5) when the WC is at the TDP where the WC velocity nullifies $v_{wc}(t_1) = 0$,

that is, $-g_l t + (V_{max} \cos \omega t_s) = 0$.

From where considering $V_{max} = \omega X_{max}$ one gets,

$$t_l = \frac{\omega X_{max} \cos(\omega t_s)}{g_1} \quad [s] \quad (11)$$

After that the corresponding instantaneous position of the pipe (valve) when WC is at TDP is found to be,

$$x_p(t_s + t_1) = X_{max} \sin[\omega(t_s + t_1)], \quad [m] \quad (12)$$

The sign of (12) changes depending on the phase at which valve is located, being positive when the valve is in Phase 1 and 3 and negative in Phase 4 and 5 [7].

Substituting (10) and (12) into (9) subsequently the new WC relative displacement is found,

$$x_{rel}^{wc} = \frac{[\omega X_{max} \cos(\omega t_s)]^2}{2g_1} + \frac{g}{\omega^2} - X_{max} \sin[\omega(t_s + t_1)] \quad (13)$$

Upon substitution of (13) into (8) the improved flow rate equation of a sonic pump is obtained. The only losses not taken into account by (8) are the head losses in the pipes. To account for them it would require calculating the resultant dimensionless head loss coefficient $K^{(R)}$ of the entire pipe system. Therefore one should take into considerations the head losses in the valve, in the straight pipe segments, local losses in reducers, elbows, water meter and other fittings involved in the pipe system. The resultant head loss coefficient is given by [9],

$$K^{(R)} = \Sigma(k_i) \quad (14)$$

where, k_i is dimensionless head loss coefficient in a particular fitting of the pipe system.

According to Kletzkina [9] to account for the head loss in the pipes the flow rate given by (3) and (8) have to be modified by using (14) as follows,

$$Q_{with\ pipe\ losses}^{Theoretical} = \frac{Q_{with\ g}^{Theoretical}}{\sqrt{\Sigma k_i}} = \frac{250\pi d_m^2 x_{rel} n}{\sqrt{K^{(R)}}}, \quad [l/min] \quad (15)$$

$$Q_{with\ all\ losses}^{Theoretical} = \frac{Q_{with\ g_l}^{Theoretical}}{\sqrt{\Sigma k_i}} = \frac{250\pi d_m^2 x_{rel}^{wc} n}{\sqrt{K^{(R)}}}, \quad [l/min] \quad (16)$$

Equation (15) accounts for the energy losses in the spring suspension system and the head losses in the pipes, while (16) incorporates all potential losses in the pump system and therefore is believed to predict better and closer the flow rate to that of the pump.

To compare the flow rates predicted by (3) and (8) as well as the corresponding (15) and (16) a comprehensive numerical analysis is performed and the results obtained are plotted against the pipe (valve) maximum acceleration.

III. RESULTS AND DISCUSSION

The numerical analysis will follow the same sequence described in the preceding section. Calculations are done for the parameters of a model low frequency sonic pump by using Excel Spreadsheet. The results obtained are presented graphically indicating the variation of the flow rates upon the pipe (valve) maximum acceleration. The design and installation parameters of the model low frequency sonic pump used in the numerical analysis and the experiments are:

- Total oscillating mass: $M = 26.3$ kg, slightly varying with the size of valves being used.
- The shaker resonance speeds: $n_{1.5''} = 325$ rev/min; $n_{2''} = 322$ rev/min; $n_{3''} = 297$ rev/min.
- The shaker rotating unbalance: $me = 0.0351$ [kg-m].
- The valve's inlet diameters for the three sizes of valves, mainly the 1.5", 2.0" and 3.0" valves $d_m^{1.5''} = 0.043$ [m], $d_m^{2.0''} = 0.055$ [m], and $d_m^{3''} = 0.080$ [m]
- Valve head loss coefficient $h_v = 0.43$ [m] assumed for all the valves, although it varies upon the size.
- Valve's submersion depth under the water level in the well: $h_s = 0.25$ m for 1.5" and 2.0" valves, and $h_s = 0.20$ m for the 3.0" valve.
- The depth of pumping $H = 1.65$ m maintained the same for all sizes of valves by varying the pipe lengths.
- Maximum pipe (valve) resonance accelerations $a_{max}^{1.5''} \cong 3.2g$; $a_{max}^{2''} \cong 3.0g$; $a_{max}^{3''} \cong 2.6g$.

The values of the individual coefficient of head losses for the fittings used in the model pump are found from [9, 10] as follow:

For a spring loaded poppet valve $k_1=4.0$; for the water meter $k_2=3.5$; for a standard 90° elbow $k_3=0.9$; for two 90° reducers $k_4=2 \times 0.24=0.48$; for a zinc plated steel pipe of length $l_1=1.2$ m of $d_{int}=0.021$ m and a plastic hose of length $l_2=4$ m and $d_{int}=0.025$ m, both having same $k=0.025$. Thus the combined head loss coefficient for the pipe and hose is

$$k_5 = \left(\frac{l_1}{d_1} + \frac{l_2}{d_2} \right) k = \left(\frac{1.2}{0.021} + \frac{4}{0.025} \right) 0.025 = 5.43$$

Therefore the resultant dimensionless head loss coefficient of the entire pipe system is

$$K^{(R)} = \sum k_i = \sum (4 + 3.5 + 0.9 + 0.48 + 5.43) = 14.31$$

Or the value of modified head loss $\sqrt{K^{(R)}}$ to be used in (15) and (16) is $\sqrt{K^{(R)}} = \sqrt{14.31} \cong 3.78$.

Further the flow rates defined by (3) and (8) are modified as per (15) and (16) to get the ultimate flow rates, which will be compared to the experimental ones discharged by a model sonic pump.

The variation of the WC retardation g_l for the model pump in terms of valve head loss h_v and valve submersion depth h_s , both varying from 0 to 1m, at a depth of pumping $H=1.65$ m is presented in Fig. 2.

Depending upon the combination of these parameters WC may retard faster if $g_l > g$ or slowly if $g_l < g$, provided that the depth of pumping H is relatively small. The above effects depreciate quickly when the depth of pumping is considerably increased and the value of g_l tends to attain at large depths the value of the gravitational acceleration [11].

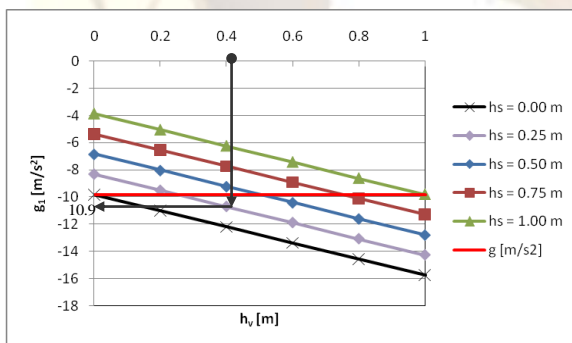

Figure 2. Retardation of the WC of a model pump, at a depth of pumping $H=1.65$ m

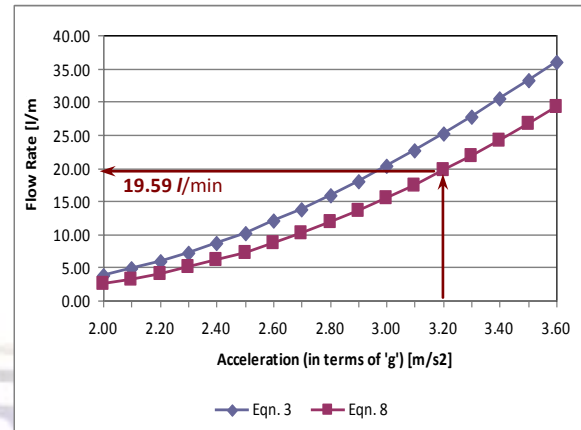

Figure 3. Flow rates of 1.5" valve at $n = 325$ rev/min,

Figs 3, 4 and 5 show the variations of the predicted flow rates estimated from (3) and (8) for the parameters of the model low frequency sonic pump. It is observed that the flow rates predicted by (3) and (8) increase whenever the valve inlet diameter increases, the acceleration increases, and the pump resonance frequency decreases. This is because the WC relative displacement is dependent upon the resonance frequency $x_{rel}^{wc} = f(\omega)$ of the system.

It is also found that the flow rates predicted by (8) are smaller than those obtained from (3). The reason is that the WC retardation g_l of the model pump is larger than the gravitational acceleration g used in (3). This is clearly indicated by the reference arrows shown in Fig. 2 pointing out that WC retardation is $g_l=10.9$ m/s² hence larger than $g=9.81$ m/s². As a result the WC retards faster than the pipes therefore a smaller flow rate results.

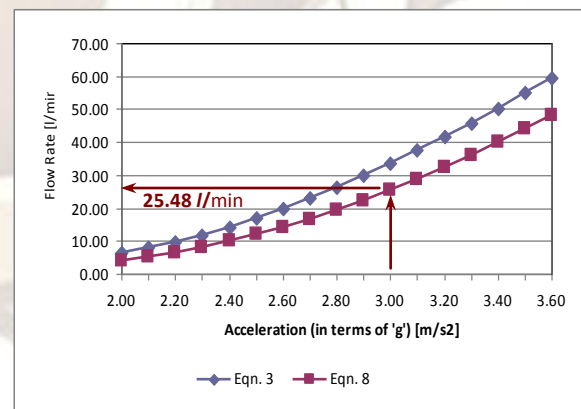

Figure 4. Flow rates of 2" valve at $n = 322$ rev/min,

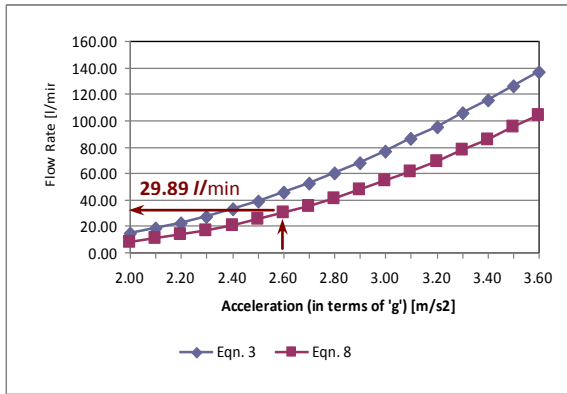

Figure 5. Flow rates of 3" valve at n = 297 rev/min,

The predicted flow rates from (3), (8) and these from the modified (15) and (16) along with the experimental flow rates discharged by a model low frequency sonic pump are listed in Table 1.

It should be noted that the average values of the experimental flow rates listed in Table 1 are based on the average flow rates obtained from three valves of the same size being tested, that is valves No. 1, 2 and valve No. 3.

Table 1. Predicted flow rates versus test results

Flow rates	Q [l/min]		
	1.5"	2.0"	3.0"
Number of valves tested	3	3	3
Flow Rates from (3)	25.21	33.53	45.56
Flow Rates from (15)	6.67	8.87	12.05
% diff. by (15) and test	26.33	50.41	48.22
Flow Rates from (8)	19.59	25.48	29.89
Flow Rates from (16)	5.18	6.74	7.91
% diff. by (16) and test	-1.33	9.24	-2.35
Average test flow rates	5.25	6.17	8.13

When comparing the flow rates obtained from (3) and (8) it is seen that (8) predicts lesser flow rates than (3). This is because (8) accounts for the WC retardation due to the valve head losses and the valve submersion depths, contrary to (3) where the WC retardation is due to the gravitational acceleration only and does not account for these effects.

The equations used in Table 1 to calculate the % difference between the flow rates predicted by (15) and (16) respectively, and the experimental (tests) flow rates are as follows:

$$\% \text{ diff. by Eq. (15)} = (Q_{\text{Eq.(20)}} - Q_{\text{Test}}) / Q_{\text{Test}} \times 100\% \quad (17)$$

$$\% \text{ diff. by Eq. (16)} = (Q_{\text{Eq.(21)}} - Q_{\text{Test}}) / Q_{\text{Test}} \times 100\% \quad (18)$$

The analysis of the data listed in Table 1 reveals that the accuracy of predicting the flow rate of the sonic pump by (16) is much better than that of (15). The reason is that (16) accounts for all potential losses in the pump. For the 1.5" and 3" valves the predictions are very close but slightly

below the experimentally determined flow rates, while for the 2" valve the prediction is on the high side making a difference of about 9%. The problem is due to the large discrepancies in the individual valve spring constants, valve spring preloads and valve strokes among the three 2" valves being tested [8]. It appears that one of the valves has very low valve spring constant with small spring preload, which delivered lesser flow rate because it allows some backflow of water to the well. These always happen to any valve if the preload is not enough to quickly close the valve and prevent a backflow when the WC tends to move towards the valve. The other two valves sizes have relatively low spring constants but somewhat higher preloads that is why they perform better than the 2" valves. As a result a smaller average experimental flow rate is obtained from all 2" valves than it is predicted by (16). Apparently, in choosing spring loaded poppet valves for sonic pumps a careful selection of the valve's mechanical parameters is required in order to avoid large variations in their performance. Of course 9.24% difference between the predicted and experimental values is usually assumed to be a reasonable discrepancy, so as the experimental flow rates obtained for the 2" valves should not be discarded as being statistically unreliable.

IV. CONCLUSION

Based on the results obtained the following conclusions are drawn:

- Equation (16) predicts accurately the flow rates of the pump for the three valve sizes than (15) as compared to the experimental flow rates discharged by a low frequency sonic pump.
- The average percentage difference between the predicted flow rates by (16) and the experimental ones is about 4.3%, contrary to the results obtained from (15) providing 42.7% difference. This indicates the importance of considering the head losses in the pipe system and their effect on the flow rate, suggesting that they should not be discarded at all.
- On the other hand the flow rates predicted by (3) and (8) and the corresponding modified (15) and (16) always increase whenever:
- The valve inlet diameter increases,
- The maximum acceleration of the system increases,
- The submersion depth of valve below the water level in the well increases, and
- The pump resonance frequency decreases.

If larger flow rate is desired it necessitates that one should increase the valve size, the acceleration, the valve submersion depth and reduce the resonance frequency accordingly. Since the valve inlet diameters are limited by the borehole internal

diameter, the 3" valves are the largest possible choice to be selected for the 160-mm boreholes. Alternatively, an excessive increase of the acceleration is generally not advisable since this cause increased energy losses, huge dynamic loads in the pipe flanges and enormous forces transmitted to the foundation.

In this regard it is always wise to keep the resonance frequency much below 20 Hz setting the acceleration between 3g and 5g and explore the useful effect of large resonance amplitudes. This will provide reasonable dynamic loading conditions to both pipe flanges, valves and pump foundation together with relatively high efficiency of the pump. It should be noted that in resonance when the frequency decreases the resonance amplitude increases and when the frequency increases the amplitudes decrease. Thus an appropriate balance between the acceleration, operating frequency, resonance amplitude, and valve submersion depth need to be established to achieve desirable flow rate, pressure developed, better efficiency and reasonable loading conditions to pump components and the foundation. To optimize the pump setup it necessities conducting a comprehensive analysis of the pump performance parameters but this will be done at later stage.

REFERENCES

- [1] Bodine A. G., Deep Well Pump. US Patent No. 2, 553, 543, 1951.
- [2] Usakovskii V.M., 1963. Vibration Method for Pumping Water from Boreholes of Small Diameters. *Proceedings of VIESH*, Moscow, 1963, 13, 10-13.
- [3] Usakovskii V.M., *Inertial Pumps* (Machine-Building Publishing House, Moscow, 1973).
- [4] Usakovskii V.M., *Water Supply and Water Transportation in Agriculture* (Kolos Publishing House, Moscow, 2002).
- [5] Loukanov I.A. and J. Uziak, 2006. *Theoretical Investigation and Experimental Analysis of Inertia Water Pump for Boreholes in the Desert and Rural Areas of Botswana*. Unpublished Research Report R569, University of Botswana, Gaborone, Botswana, 2006.
- [6] Loukanov I.A. and J.E. Johnson, Design Features and Experimental Analysis of a Resonance Pump for Boreholes in Botswana. *Mechanics of Machines*, 71(5), 2007, 15-19.
- [7] Loukanov I.A., Investigating the Pumping Process of a Resonance Vibrating Pump for Medium-depth Boreholes. *Research in Agricultural Engineering*, 53, 2007, 172-181.
- [8] Loukanov I.A., Measuring the Parameters of Foot Valves for Sonic Pumps. *Journal of*

Emerging Trend in Engineering and Applied Sciences, 1 (2), 2010, 184-189.

- [9] Kletzkin M.N., *Handbook of Machinery Design* (Machine-Building Publishing House, Moscow, 1969)
- [10] Douglas J.F., Gasiorek J.M., Swaffield J. A. and L.B. Jack, *Fluid Mechanics*. (Prentice Hall, 2005)
- [11] Loukanov I.A., J. Uziak, 2011. Investigating the Effect of Valve Submersion Depth on the Flow Rate of Sonic Pumps. *Global Journal of Researches in Engineering, A Mechanics & Mechanical Engineering*, 11, 7, 2011, 73-78.