

UNCLASSIFIED

~~CONFIDENTIAL~~

HISTORY
OF THE
REDEYE WEAPON SYSTEM

S E C U R I T Y

This document is considered for official use only and contains information affecting the National Defense of the United States within the meaning of the Espionage Laws, Title 18, U.S.C., Sections 793 and 794. The transmission or the revelation of its contents in any manner to an unauthorized person is prohibited by law.

Distribution outside the Department of the Army will not be made except with the approval of the Chief of Military History, per paragraph 7-6, AR 870-5, 18 June 1971.

UNCLASSIFIED

~~CONFIDENTIAL~~

REQUEST FOR OR NOTIFICATION OF REGRADING ACTION
(AR 380-5)

FILE

DATE

26 Feb 75

NOTE: Read instructions on reverse side before completing this form.

TO:

FROM:

Historical Division, US Army Missile Command, Redstone Arsenal, Alabama 35809

- THE DOCUMENT(S) DESCRIBED BELOW HAS/HAVE BEEN REVIEWED FOR REGRADING AND ACTION HAS BEEN TAKEN AS INDICATED. APPROPRIATE ACTION SHOULD BE TAKEN TO MARK YOUR COPIES AND NOTIFY ALL RECIPIENTS TO WHOM ADDITIONAL DISTRIBUTION WAS FURNISHED IN ACCORDANCE WITH AR 380-5. DOCUMENTS CONCERNING THIS SAME SUBJECT SHOULD BE REVIEWED FOR POSSIBLE REGRADING.
- REQUEST DOCUMENT(S) DESCRIBED BELOW BE REVIEWED TO DETERMINE WHETHER THEY CAN BE DOWNGRADED OR DECLASSIFIED AT THIS TIME. (Include justification in the Remarks Section of this form.)
- REQUEST APPROPRIATE GROUP MARKINGS FOR DOCUMENTS DESCRIBED BELOW.
- DOCUMENT(S) DESCRIBED BELOW HAS/HAVE BEEN PLACED IN A DIFFERENT GROUP AND WILL BE RE-MARKED IN ACCORDANCE WITH AR 380-5 AND AR 380-6.

CONTROL NUMBER <i>a</i>	DOCUMENTS (Type, Headquarters of Origin, Date, Subject or Short Title) <i>b</i>	CLAS OF SUBJ <i>c</i>	INCL <i>d</i>	CLAS AND GP NO. <i>e</i>	RE-GRADED TO CLAS & GP NO. <i>f</i>
928753	History of the REDEYE Weapon System (Historical Monograph AMC 79M).	U		S-GDS	C-XGDS-3 U-198/ * See Remarks

AUTHORITY OR COMMAND LINE (When applicable)

HELEN B. JOINER, Chief, Historical Division

PRINTED OR TYPED NAME AND TITLE OF OFFICER

SIGNATURE

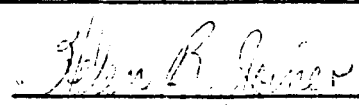

REMARKS

Classified by REDEYE Security Classification Guide, 1 November 1974.

1st Indorsement

INSTRUCTIONS

1. Prepare sufficient number of copies to furnish one copy to each addressee of the original document and one copy for retention. Entries on form may be printed in ink.

2. Care will be taken to completely identify the document(s) being regraded to prevent error by the recipient. All inclosures being regraded will be accounted for in the inclosure column. When covering document only is being regraded and there are inclosures (classified or unclassified) which are not being regraded, the symbol "n/c" will be entered in the inclosure column. The regrading form will contain unclassified information only. Short titles will consist of the first letter of each word in the subject or title except when a formal short title has been assigned.

3. The following symbols will be used (for purposes of this form only) to indicate the classification of the document(s) or portions thereof and protective marking to be affixed:

- TOP SECRET-----TS
- SECRET-----S
- CONFIDENTIAL-----C
- CONFIDENTIAL Modified Handling Authorized---CM
(CM - not to be used for classification of subject or title)
- UNCLASSIFIED-----U
- UNCLASSIFIED FOR OFFICIAL USE ONLY-----U-OFLUSE

(Indicate in parentheses the number of years from date of origin OFLUSE will be removed from document.)

4. When the document(s) will be regraded upon the occurrence of an event, the classification will be followed by an asterisk (*) and the event described on the bottom of the form or in "Remarks" above.

5. When the form is used as a request for review, the need for a lower classification for the document or documents will be shown. When the classification of the subject or title standing alone is unknown to the holder of the document, the symbol "?" will be placed in the column headed "Classification of Subject." When the form is used as a notification, the current classification of the subject or title will be indicated in this column using the symbols shown in paragraph 3 above.

UNCLASSIFIED

~~CONFIDENTIAL~~

HISTORY
OF THE
REDEYE WEAPON SYSTEM

Mary T. Cagle

Approved by:

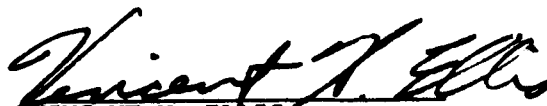

VINCENT H. ELLIS
Major General, USA
Commanding

Issued by: Helen Brents Joiner
Chief, Historical Division
Army Missile Command
23 May 1974

Historical Monograph
Project Number: AMC 78M

UNCLASSIFIED

~~CONFIDENTIAL~~



REDEYE Missile Poised for Firing

PREFACE

A major network, in its TV morning news of 13 August 1973, carried a story on the Marine Corps maneuvers being held at Twenty-Nine Palms, California, in the Mojave Desert. In one sequence, showing battlefield action and massive troop movements, a Marine gunner hefted a REDEYE anti-aircraft guided missile to his shoulder, took aim, and shot down a target drone in a mock low altitude attack on ground combat units. This vividly portrayed the vital air defense role of the REDEYE missile system which joined the arsenal of operational weapons in 1967.

This monograph traces the history of the REDEYE weapon system from its inception in the mid-1950's through 1973. Except for the chapter dealing with project management, the REDEYE story is related in basically chronological sequence. It begins with the origin of the project and progresses through the feasibility studies, engineering development, production, system deployment, and on through early work on the second-generation STINGER weapon system, which is being developed as a replacement for the basic REDEYE.

17 May 1974

Mary T. Cagle

TABLE OF CONTENTS

<i>Chapter</i>	<i>Page</i>
I. ORIGIN OF THE REDEYE PROJECT	1
The War Department Equipment Board	1
The STINGER Project.	2
New Equipment Development Guides of 1950	2
The HAWK Project	3
The PORCUPINE and OCTOPUS Projects	4
Revision of the Army Equipment Guide	5
Advent of the REDEYE Concept	6
Statement of Requirement	14
Evaluation of Weapon System Proposals.	15
Establishment of the REDEYE Project.	17
II. PROJECT MANAGEMENT STRUCTURE	19
Formation of the Project	19
The AOMC/ARGMA Era—1958-61.	20
The MAULER-REDEYE Project Office	24
The REDEYE Commodity Office—1962-64	26
The REDEYE Project Office—1964-71	28
The Air Defense Special Items Management Office— 1971-73	34
III. FEASIBILITY STUDY PROGRAM.	36
Human Factors Tests.	37
Target Radiation Tests	38
Flight Tests	39
Establishment of Military Characteristics.	43
Recommendation for Initiation of R&D Program	45
Engineering Development Program Approved	50
The Updated Commodity Plan	51
IV. BASIC ENGINEERING DESIGN	54
Contractor Structure	55
Development Concept and Target Dates	57
Component Development - Experimental Model	59
Seeker Head.	60
Control Section.	63
Electrical Power Section	64
Warhead Section.	64
Propulsion System.	66
Launcher/Gripstock Assembly.	69
Development Test Program—1960	73
LTV-1 Firings.	73
LTV-1B Firings	75
GTV-2 Firings.	76
The Abortive FY 1961 Procurement Program	78

Chapter

Page

V. ENGINEERING DESIGN REFINEMENT.	83
Compromise in the MC's	84
Missile Design	88
Roll Rate Problem.	88
Rocket Motor Problems.	91
Guidance and Control Refinements	92
Tactical Prototype Delivery Schedule	93
Proof Tests of the Tactical Shoulder Launcher.	93
Firings in Support of the System Demonstration	94
The System Demonstration	95
Design Release Inspection and Schedule Revision.	98
Weapon System Analysis	99
Seeker Sensitivity	100
Miss Distance Investigation.	101
Roll Rate Investigation.	101
Accelerated Firing Program	102
Revision of the Program Schedule	107
Implementation of the Reoriented Program	109
Deferment of FY 1963 Procurement	112
Transition from R&D to Production.	115
FY 1963-64 Development Costs	116
Improvement in System Performance & Reliability.	117
Release for Limited Production	118
VI. INDUSTRIAL AND PRODUCT IMPROVEMENT PROGRAMS.	121
Production Base Line	122
Block I (XM-41) System - FY 1964	123
Block II (XM-41E1) System - FY 1965.	127
Block III (XM-41E2) System - FY 1966-68.	131
The Standard M41 Weapon System	143
Type Classification.	143
FY 1969-73 Procurements.	153
Weapon System Procurement Summary.	155
Air Force and Navy Applications.	157
Air Force RAM Program.	157
Helicopter RAM Program	159
The Navy REDEYE Program.	160
VII. TRAINING EQUIPMENT	162
The M46 Series Field Handling Trainer.	163
Electronic Trainers.	167
XM-42 Electronic Trainer	167
Interim XM-49 Tracking Head Trainer.	169
The Standard M76 (XM-49E3) Training Set.	170
M87 Moving Target Simulator.	175

<i>Chapter</i>	<i>Page</i>
VIII. WEAPON SYSTEM DEPLOYMENT.	182
Employment/Deployment Concepts.	182
Employment Missions	183
Organization.	183
Training Program.	190
Gunner and Controller Training.	190
Maintenance Training.	192
Implementation of Army Deployment Plans	192
Stratification of Army REDEYE Weapons	196
IX. THE REDEYE IMPROVEMENT PROGRAM.	198
Advanced Sensor Development Program	199
Establishment of MANPADS Requirement.	203
Advent of the STINGER Project	204
X. CONCLUSION.	207
GLOSSARY.	211
INDEX	219

CHARTS

<u>No.</u>		
1.	(U) USAOMC Chain of Command, Mar 58 - Jul 62.	21
2.	(U) AOMC Organization Chart, 2 Apr 62	25
3.	(U) REDEYE Project Manager Organization Chart, 9 Jun 64	30
4.	(U) MICOM Organization Chart, 29 Jan 65	31
5.	(U) REDEYE Provisional Commodity Plan, Nov 58	48
6.	(U) REDEYE Commodity Plan, 30 Nov 59.	52
7.	(U) REDEYE Organization	186
8.	(C) Allocation of REDEYE Teams to U. S. Army Division (U)	187

TABLES

1.	(U) REDEYE Program Estimate	49
2.	(C) M41 REDEYE System Characteristics (U)	146
3.	(C) M41 REDEYE System Capabilities vs MC's (U).	147
4.	(C) Major Production Contracts with General Dynamics.	156
5.	(C) PEMA Cost Summary - REDEYE Missile System Major Items (U).	158
6.	(C) Principal Item Distribution Plan - Guided Missile Intercept-Aerial Trainer, M46, M46A1, & M46A2 (U).	165
7.	(U) M87 Moving Target Simulator Revised Schedule as of 30 June 1973.	181
8.	(S) Stratification of Army REDEYE Weapons—FY 1966-79 (U)	197
9.	(C) REDEYE Cost Summary	209

LIST OF ILLUSTRATIONS

	<i>Page</i>
(U) REDEYE Missile Poised for Firing.	Frontispiece
(U) REDEYE Weapon Experimental Model.	9
(U) Structural Arrangement of Proposed REDEYE Missile (Nov 56).	10
(U) Missile Wing Extension Linkage.	11
(U) Tail Fin and Nozzle Assembly.	11
(U) REDEYE System Operation	12
(U) REDEYE Missile Sectionalization (31 Dec 59)	61
(U) REDEYE Rocket Motor Characteristics	68
(U) REDEYE Launcher External Configuration.	70
(U) REDEYE Tactical Simulator	72
(U) Army Lieutenant Shoulder Fires the REDEYE for the President	103
(U) XM-147/XM-147E1 (Block I/II) Launcher	134
(U) XM-171 (Block III) Launcher	134
(U) Cutaway View of XFIM-43C (Block III) REDEYE Missile	135
(C) REDEYE Flight Sequence (U).	148
(U) REDEYE Weapon System Major Items, 7 Mar 69.	149
(U) FIM-43C Guided Missile, Intercept-Aerial.	150
(U) REDEYE Launcher Section Components.	151
(U) REDEYE Weapon System in Depot Storage, Aug 70	152
(U) Intercept-Aerial Trainers M46 and M46A2	166
(U) Intercept-Aerial Trainers XM-49 and XM-49E1/E2.	171
(U) M76 (XM-76) Training Set.	174
(U) M87 Moving Target Simulator	179
(U) REDEYE Target Types	184
(C) Division Deployment Overview—Typical Area Defense (U).	188
(C) Procurement Items - U. S. Basis of Issue (U).	189
(U) Troop Training Test at Orogrande Range.	191
(C) Missile Configurations - Basic REDEYE and REDEYE II (U)	205

CHAPTER I

ORIGIN OF THE REDEYE PROJECT (U)

(U) The REDEYE low-altitude air defense weapon released for use by Army and Marine Corps troops in 1967 was the product of an evolutionary development effort that began after World War II. In that span of more than two decades, significant progress was made in developing highly sophisticated antiaircraft guided missiles to counter the high- and medium-altitude threat. But the development of a small, man-portable infantry weapon to protect the foot soldier against attack by low-flying, strafing planes and close-support aircraft proved to be an exceedingly difficult task. The search for such a weapon to replace the standard .50-caliber machine gun was largely influenced by the recommendations of a number of army equipment review boards and tripartite conferences on antiaircraft equipment.

The War Department Equipment Board

(U) Concluding that the mission of the infantryman was the most difficult in modern war, the War Department Equipment Board, in May 1946, emphasized the importance of providing him with the very best equipment that this nation could produce. It called for the highest priority in the allocation of lightweight materials for man-carried and man-handled equipment. In addition, it asserted that such equipment should be simple to produce, operate, and maintain, and be capable of being separated into loads weighing not more than 25 pounds each. In the specific area of short-range, low-altitude antiaircraft weapons, the board concluded that the existing .50-caliber machine gun did not have sufficient range or

velocity for use against targets of the future. It therefore recommended that an antiaircraft machine gun of suitable caliber be developed for use at short ranges, from 200 to 2,500 yards, against targets flying near the ground at speeds up to 1,000 miles per hour (mph). This weapon was to have free, truck-cab, and multiple mounts of static, trailer, and self-propelled types.¹

The STINGER Project

(U) Accordingly, the Ordnance Corps, in June 1948, began work on the STINGER weapon which consisted of four .60-caliber machine guns, on either a towed or self-propelled mount, and an integrated, on-carriage, radar-directed fire control system. Work on this system continued until 1951, when the developer determined that the .60-caliber guns would not meet the new requirement for an effective slant range of up to 14,000 feet. A 37-mm. revolver-type gun was later built and tested for possible use with a modified STINGER system, but it proved to be too complex and unreliable, and the project was finally terminated.²

New Equipment Development Guides of 1950

(U) The new Army Equipment Development Guide (AEDG), published in December 1950, stated a requirement for a family of optimum performance weapons and fire control equipment capable of

¹(1) War Dept Equipment (Stilwell) Bd Rept, 29 May 46, p. 25.
(2) TIR CD-7, OCO, Dec 60, subj: Dev of Inf Wpns, p. 12. Both in Redstone Scientific Information Center (RSIC).

²(1) TIR CD-1, OCO, Jun 60, subj: Dev of AD Wpns, p. 6. RSIC.
(2) Another STINGER project was established early in 1972, but the similarity between the two programs was purely coincidental. Originally known as the REDEYE II, the modern-day STINGER was being developed to replace the basic REDEYE weapon system.

engaging and defeating all enemy aerial vehicles having speeds of up to 1,000 mph, altitudes of from ground level to 60,000 feet, and horizontal ranges of up to 27,000 yards. Included in the recommended family of antiaircraft weapons was an all-arms system suitable for mounting on a ground mount, truck cab mount, or armored vehicle, excluding tanks, to engage effectively low-flying targets from 0 to 1,000 feet. While recommending that the .50-caliber air-cooled machine gun be retained as an infantry weapon on a short-term basis, the review board emphasized the need for a vastly improved low-altitude antiaircraft weapon having a longer range, greater accuracy, and a higher cyclic rate.³

The HAWK Project

(U) Following a study of the capabilities of existing and development-type aircraft, the Army Field Forces,^{*} in early 1951, established a formal requirement and military characteristics for a surface-to-air guided missile capable of protecting units in forward combat areas from attack by low-altitude aircraft. From these military characteristics, the HAWK (Homing All The Way Killer) guided missile system evolved; however, it acquired technical characteristics that made it suitable for the division and Corps areas only.⁴

^{*} Later redesignated and hereafter referred to as the Continental Army Command (CONARC).

³ AEDG, Dec 50, pp. 21, 47-48. RSIC.

⁴ (1) DOD Rept 302/4, Jul 56, subj: Rept of the Ad Hoc Gp on LA Antiaircraft Systems, p. 36, & App II thereto, DOD Rept 302/3, Jun 56, p. 69. RSIC. (2) The HAWK development program was established in April 1953, industrial deliveries began in January 1958, and the first HAWK missile battalion was activated in June 1959. HAWK Chronology. Hist Div File.

The PORCUPINE and OCTOPUS Projects

(U) At the Tripartite Conference held in London during 1950, it was agreed that the U. S. Army .50-caliber machine gun would be an acceptable weapon for defense against low-flying aircraft from 1950 to 1960, but that after 1960 a new system would be required for use against 800-mph airplanes flying at altitudes of up to 1,000 feet. The PORCUPINE and OCTOPUS projects were subsequently established to meet the newly stated low-altitude air defense requirements, but neither of these was ever made operational.

(U) Work on Project OCTOPUS was begun in 1953. Before its cancellation in 1957, work was done on the .50- and .60-caliber mount and 20-mm. weapon systems. A unique "great circle" mount, the T176 short-range antiaircraft gun mount, was developed for tracking along a slant range up to 35° from the horizontal, as well as in azimuth and elevation. Its design principles were also used in the T189 and T190 mounts, for which development of the T220 and T247 20-mm. automatic guns was undertaken.

(U) In the meantime, feasibility studies in 1951 resulted in work on the PORCUPINE, which was a proposed system for coping with possible attacks, after 1960, on the Continental United States by fighter-bomber planes, at altitudes of from 50 to 6,000 feet and ranges of between 3,000 and 6,000 feet. A PORCUPINE battery was to have comprised 64 launching tubes that could fire 2.75-inch rockets at the rate of 6,000 per minute. No complete PORCUPINE system was ever built. The project was terminated in February 1956, after it was decided that its continuation was no longer justified.⁵

⁵TIR CD-1, Jun 60, p. 7. RSIC.

Revision of the Army Equipment Guide

(U) By the mid-1950's, antiaircraft weapons at medium and high altitudes were becoming so effective that an increasing proportion of attack aircraft could be expected to enter the battle area at low altitudes. The ever-increasing speed and maneuverability of low-flying aircraft decreased the time of warning and effective action and increased the required effectiveness of low-altitude air defense weapons. The standard automatic weapons—the caliber .50 and 40-mm.—were rapidly becoming obsolete because of their short range, low lethality, and inability to engage high-speed, low-altitude targets. Moreover, the existing methods of fire control with these weapons were characterized by visual tracking and target speed estimation applied to inexact mechanical sighting devices. For slow-speed targets, where the time available for engagement was not critical, the approximate solution produced by the existing methods was only marginally satisfactory. The existing fire control methods were totally inadequate to meet the challenge of high angular tracking rates and the short engagement periods of high-performance aircraft. Additionally, they were totally ineffective at night and under bad weather conditions. Nevertheless, the .50 caliber machine gun would remain the standard all-arms antiaircraft weapon until satisfactory solutions could be found to the complex problems posed by the low-altitude air threat.

(U) In recognition of the increasing threat to combat troops and installations in the forward area, the revised AEDG, published in 1954, restated the requirement for an all-arms antiaircraft weapon to engage low-flying targets from 0 to 1,000 feet, and recommended that first priority be placed on the provision of weapons to counter the low-altitude (0 to 10,000 feet) air threat. (Aside from the all-arms weapon to cover the altitude zone up to

1,000 feet, the latter included light antiaircraft weapons to engage enemy aircraft at altitudes up to 10,000 feet.*) The fire control equipment for the all-arms antiaircraft weapon was to be a light, rugged sight small enough for mounting on the weapon without impairing operation, and it was to be operable by the gunner alone. Since the weapon would be provided primarily for self-defense, it was essential that the sight be particularly effective on targets flying incoming courses. To facilitate operations during hours of poor visibility, the review board recommended that emphasis be placed on research for the military application of infrared techniques. Specifically, infrared equipment was to be explored for possible use in the detection, positioning, and tracking of airborne targets and in target location and homing guidance for guided missiles.⁶

Advent of the REDEYE Concept

(U) Drawing upon its years of experience as a Navy missile development contractor, Convair, a division of General Dynamics, in 1955 began feasibility studies of a very lightweight, man-transportable, low-altitude missile system to fulfill the stated requirement for an all-arms weapon to protect combat and support troops in the battle zone. Preliminary studies indicated that judicious application of several design principles, both proven and radical, could bring this surface-to-air missile system into reality. Intensive technical effort was required, however, to

* For a history of the unsuccessful Light Antiaircraft Development Program, see Mary T. Cagle, *History of the MAULER Weapon System* (MICOM, 19 Dec 68).

⁶ (1) DOD Rept 302/4, Jul 56, subj: Rept of the Ad Hoc Gp on LA Antiaircraft Systems, p. 1, & App II thereto, DOD Rept 302/3, Jun 56, pp. 1, 84. (2) AEDG, 3 May 54, w Ch 1, 3 Nov 54, pp. 45-46, 48, 50-51, 76-77. All in RSIC.

confirm the results of these studies. In January 1956, Convair engineers, using corporate funds, undertook an 11-month design program to develop the concept. Since no military characteristics for such a weapon existed at that time, they formulated a set of design objectives and proceeded to fabricate a functional, full-scale model of the missile which they named the REDEYE because of its infrared homing device.⁷

(U) The initial test model consisted of an electronic section, a control section, and an infrared homing head similar to that used in the existing SIDEWINDER* missile. This entire control system was housed in a container, or airframe, which simulated the weight, balance, and configuration of the ultimate missile. The warhead, propellant grains, fuze, and thermal battery were not included in the laboratory test model; however, no difficulty was foreseen in the development of these components. A gripstock and launching tube were built to complete a mockup of the REDEYE weapon system. The test vehicle was subjected to 8 hours of wind tunnel testing

*The first passive infrared homing weapon to become operational with American military forces, the SIDEWINDER air-to-air missile was developed by the Naval Ordnance Test Station at China Lake, California, and produced by the Philco Corporation and General Electric Company, both of which participated in the guidance system manufacture. The development program began in 1950 and the system became operational in 1956. The solid-propellant missile was 9.1 feet long by 4.8 inches in diameter and weighed 155 pounds. The infrared seeker occupied a space about 4 inches long by 4 inches in diameter in the blunt nose of the missile, and was capable of sensing and homing at a maximum range of some 5 miles. Discounting the rounded nose portion, the entire guidance system was contained in the forward 11 inches of the missile. The SIDEWINDER's unit cost was about \$3,000. Frederick I. Ordway, III, & Ronald C. Wakeford, *International Missile and Spacecraft Guide* (N. Y., 1960), p. USA 34.

⁷REDEYE Program History, atchd as App A to Convair Rept CR-590-577-012, Oct-Dec 60, subj: REDEYE Dev Program - Interim Tech Rept. RSIC.

UNCLASSIFIED

~~CONFIDENTIAL~~

and its guidance performance was predicted on the basis of 400 hours of analog computer analysis. From the data accumulated in these and other experiments, Convair published details of the proposed REDEYE system in three volumes, and made a comprehensive presentation to representatives of the U. S. Army and Marine Corps on 30 November 1956.⁸

(U) Designed to be carried and shoulder-launched by individual field personnel using a bazooka-type launcher, the proposed REDEYE missile compared favorably in size and weight with the 2.75-inch Folding Fin Aircraft Rocket (FFAR). It was 2.75 inches in diameter and 42.75 inches long, and had a gross weight of 14.5 pounds distributed as follows:

Infrared Seeker Head.....	1.00
Electronics Section.....	.25
Auxiliary Power Supply & Controls.....	1.90
Warhead.....	2.35
Booster Motor with Curved Folding Tail Fins...	0.90
Rocket Motor.....	8.10

The launching tube and gripstock weighed 3.7 pounds, giving a total weapon system weight of only 18.2 pounds. A brief summary of the system's technical characteristics follows.

(U) The proposed REDEYE used a passive heat-homing guidance system, wherein the receiver in the missile used radiation from the target with no provision for target illumination by any outside source. It was designed to follow essentially a proportional navigation course to intercept, using target position and rate information obtained from the infrared (IR) seeker. For simplicity, the missile would be launched directly toward the target.

(U) The initial boost phase would develop 700 pounds of thrust

⁸(1) *Ibid.* (2) DA Rept, 1 Oct 58, subj: R&D Anl GM Rept, p. 73. (3) Convair Rept R6-300-008, Vol 3, Nov 56, subj: REDEYE Tech Ppsl. Both in RSIC.

~~CONFIDENTIAL~~

UNCLASSIFIED

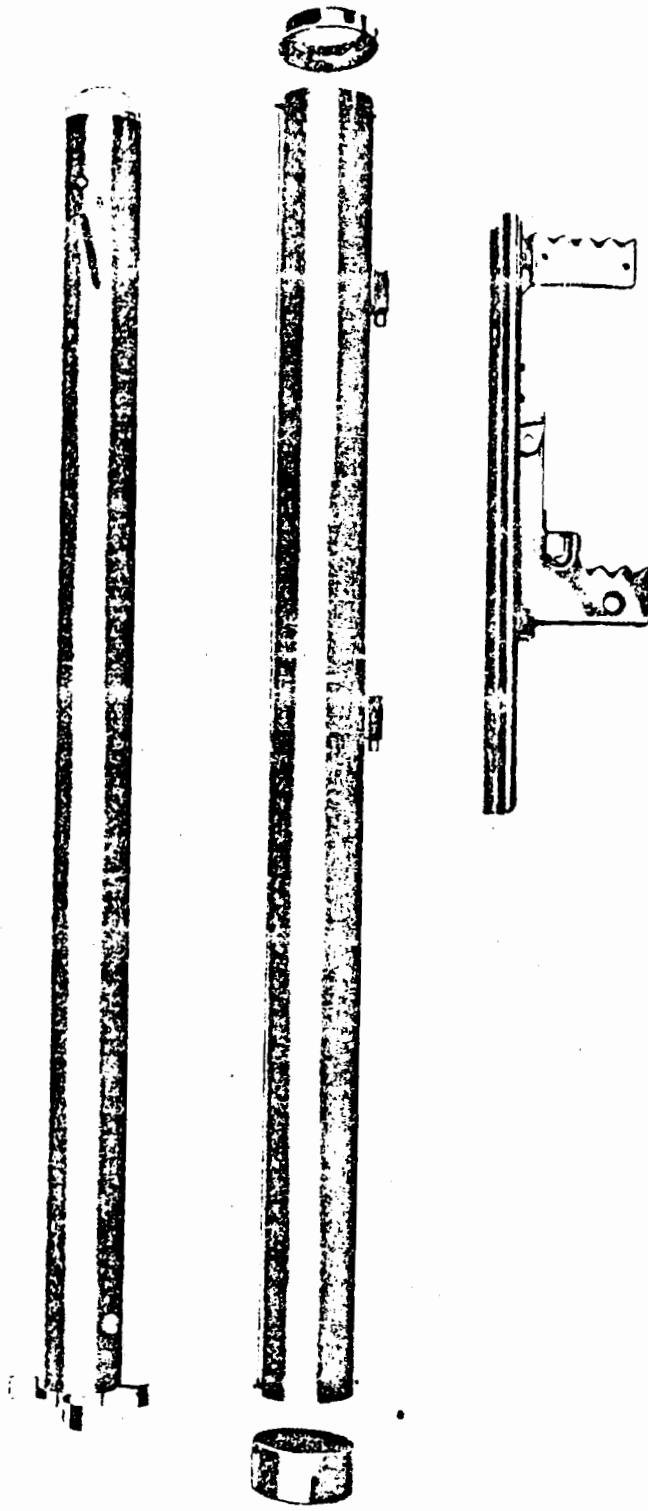

(U) REDEYE Weapon Experimental Model

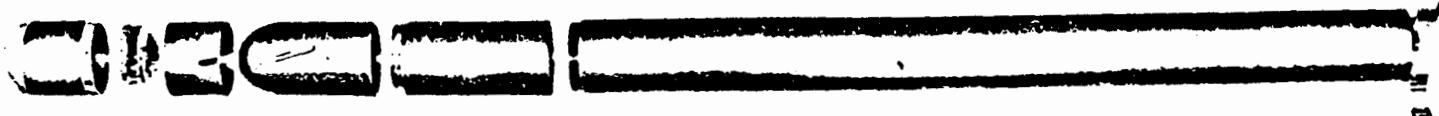

10

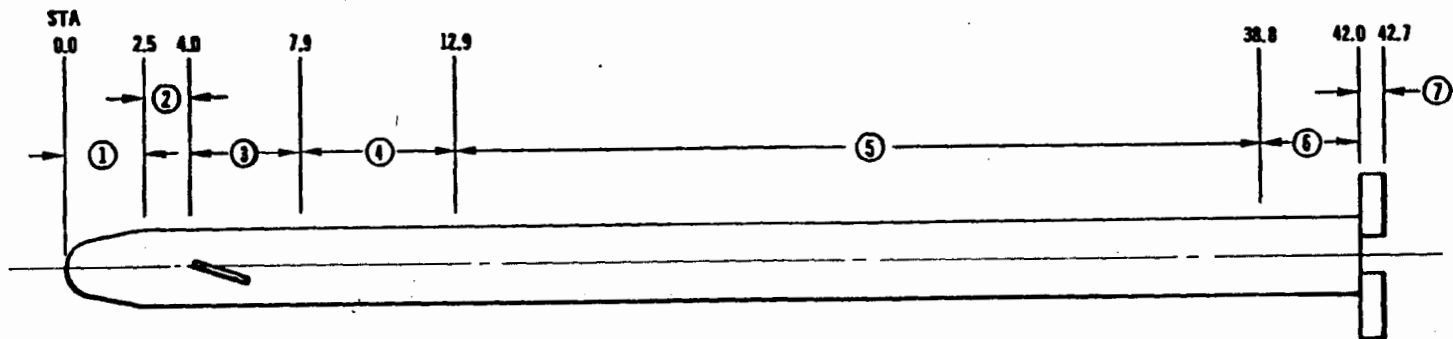

- 1. SEEKER HEAD
- 2. ELECTRONICS
- 3. CONTROLS
- 4. WARHEAD
- 5. ROCKET MOTOR
- 6. NOZZLE & BOOST MOTOR
- 7. TAIL FINS



(U) Structural Arrangement of Proposed REDEYE Missile (Nov 56)

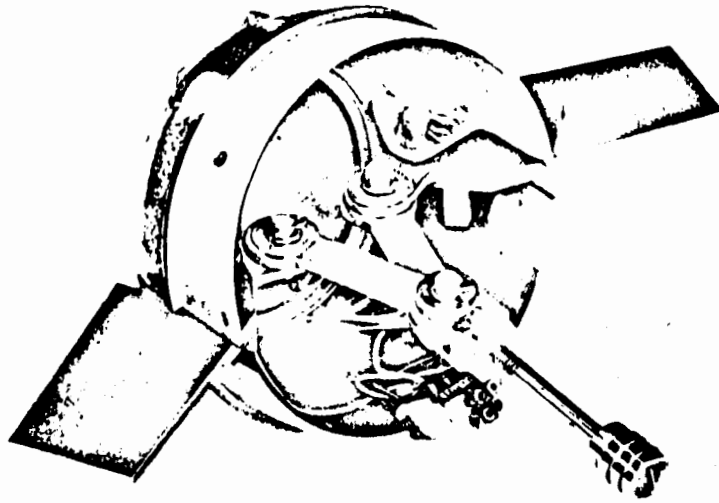

Wing Extension Linkage

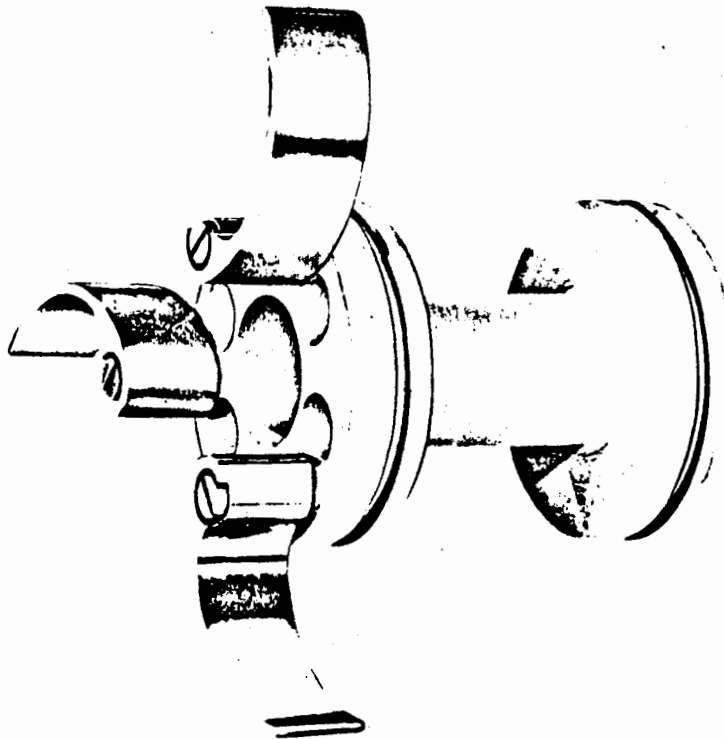

Tail Fin and Nozzle Assembly

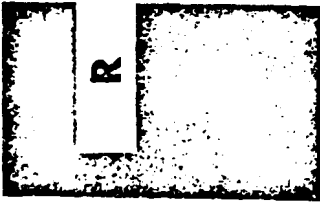

R E D E Y E

SYSTEM OPERATION

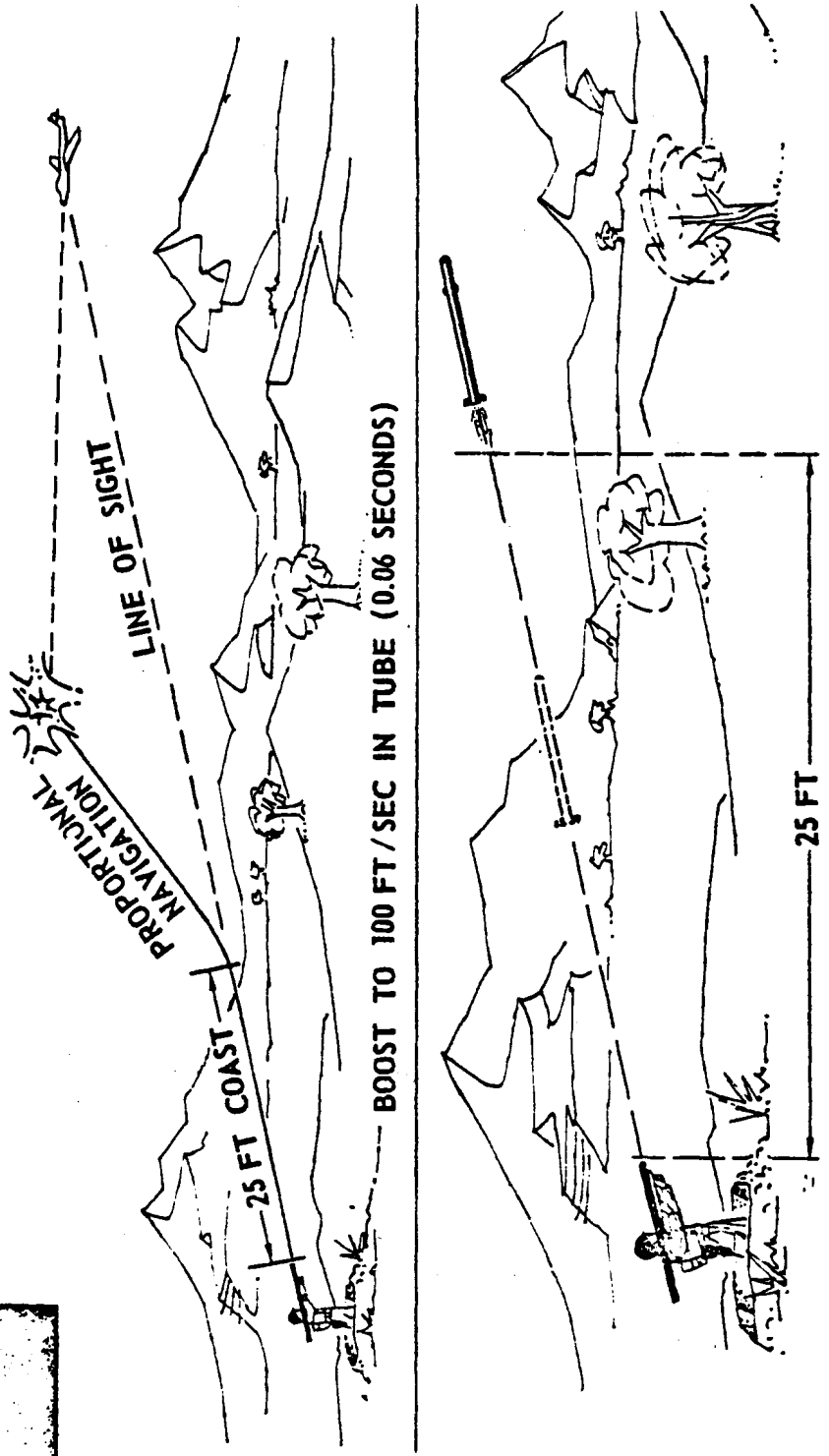

~~UNCLASSIFIED~~
~~CONFIDENTIAL~~

for 0.062 second (3 feet of travel), with booster burnout occurring in the launch tube and resulting in a terminal velocity of 100 feet per second (fps). After a delay of 0.25 second (at which time the missile would be 25 feet from the launching tube and a safe distance from the gunner), the main stage rocket motor would ignite and develop 282 pounds of thrust for 4.4 seconds, resulting in a terminal velocity of 2,700 fps. Guidance would be possible to a terminal velocity of 1,500 fps. Control of the missile would be accomplished by means of a set of fixed angle, retractable fins. The missile would roll continuously during flight. The roll rate would be established during launch by means of canted nozzles, and maintained during flight by canted tail fins.

(U) The REDEYE would use a 1.2-lb. HBX warhead and a contact fuze, which would require that a direct hit be made on some portion of the aircraft structure in order to assure a high kill probability. The results of preliminary analog computer studies indicated that a miss distance of 4 to 8 feet could be obtained within the performance boundaries. A direct hit probability of 0.35 to 0.40 was predicted. The expected maximum impact range was about 2 nautical miles.

(U) Encouraged by the results of their preliminary design work, the Convair engineers recommended that the proposed REDEYE weapon system be developed to operational readiness at the earliest possible time. With this objective in mind, they formulated a system development plan which called for a three-phase effort. In the first phase, the feasibility of the basic weapon system concept would be proven by 30 flight tests, using modified 2.75-inch FFAR's* as test vehicles, and preliminary specifications

* A survey of existing rocket motors indicated that the 2.75-inch air-to-air rocket, manufactured by the Aerojet General Corporation, came the closest to duplicating the REDEYE propulsion requirements and would provide an adequate range for proof testing the guidance and control system.

~~CONFIDENTIAL~~
~~UNCLASSIFIED~~

UNCLASSIFIED

~~CONFIDENTIAL~~

and drawings would be prepared for use in the selection of future members of the development and production team. Assuming a contract date of January 1957, Phase I would continue through December 1957. In Phase II, beginning in mid-1957 and continuing through December 1958 (18 months), the development and production team would be established, the prototype weapon design would be developed and proofed by flight test of 400 missiles, and pilot production would begin. In the final phase, the missile would be placed in quantity production at a rate of 5,000 per month and a personnel training program would be established preparatory to integration of the REDEYE into service use. The total estimated cost for Phases I and II, including \$1,010,000 for additional facilities, was \$10,430,000. The unit cost for initial production of 150,000 units at the rate of 5,000 per month was estimated at \$900. A unit cost approaching \$700 was predicted for subsequent lots.⁹

Statement of Requirement

(6) The Qualitative Materiel Requirements for the all-arms, low-altitude air defense system were published in the Combat Development Objectives Guide (subparagraph 737b[5]) on 10 July 1957. The complete statement of requirement, which was obviously built around the alleged capabilities of the proposed REDEYE, follows.

A self-contained, very lightweight, low altitude, air defense weapon system designed to seek out and destroy all aerodynamic targets traveling at speeds up to 600 knots and at ranges up to 4100 meters. The missile and launcher combination must be of such size and weight that it can be handcarried and operated by one man. The missile must contain a guidance system which is capable of

⁹ (1) *Ibid.* (2) Convair Rept R6-300-008, Vol 2, Nov 56, subj: REDEYE Sys Dev Plan. RSIC.

~~CONFIDENTIAL~~

UNCLASSIFIED

UNCLASSIFIED

~~**CONFIDENTIAL**~~

effecting an engagement when pointed in the general direction of the target and must not depend upon any outside source of energy for proper functioning except for external warm-up power and the energy radiated by the target. The system must be capable of being used by the ground combat forces for defense against attacks by low flying aircraft in areas not adequately protected by organic air defense elements. It is desired that the system have a capability of ground fire support, particularly in the antitank role, without modification to fire control or launching equipment. The weapon will replace the M63 and ring mounted caliber .50 HB machine gun as an air defense weapon. . . . This item is required by FY 61.¹⁰

Evaluation of Weapon System Proposals

(U) In 1957, three defense contractors submitted to Redstone Arsenal unsolicited proposals for an all-arms, man-portable weapon to fulfill the requirements set forth in the Combat Development Objectives Guide. Aside from Convair's REDEYE proposal, which had been presented to Army and Marine Corps representatives in November 1956, the Arsenal evaluation team, chaired by Mr. Francis W. DuVall, considered the LANCER proposal by the Sperry Gyroscope Company and the SLAM (Shoulder-Launched Antiaircraft Missile) proposal by North American Aviation, Inc.

(U) The evaluation team was not completely sold on either of the proposals. Sperry's LANCER missile was not shoulder-launched and was far too heavy to be carried and operated by one man. Though designed for shoulder-launching, the SLAM system was too heavy to meet the requirements of a man-portable weapon, its weight being about 50 pounds. The members of the evaluation team concluded that Convair's REDEYE system offered the best potential of meeting the military requirements, but recommended that it not be committed to development until certain obvious shortcomings and

¹⁰Quoted in REDEYE Msl Sys Plan, ARGMA MSP 8, 15 Feb 60, p. B-6. RHA Bx 14-209.

~~**CONFIDENTIAL**~~

UNCLASSIFIED

and problem areas had been thoroughly investigated in a program of supporting research. They found, for example, that the REDEYE was not structurally sound as designed, but probably could be made to perform as claimed in the proposal with an improved infra-red seeker and a system weight increase. Among specific shortcomings and potential problem areas of prime concern were (1) obvious errors in adopting values of IR radiation levels emanating from typical target aircraft; (2) the limited zone of effectiveness coverage; (3) questions concerning the feasibility of the unique guidance and control scheme; (4) the effect of background radiation on target detection and missile guidance (i.e., the ability of the seeker to discriminate between target radiation and background radiation, such as a hot spot on the horizon); and (5) the human factors associated with the use of the weapon, particularly the ability of service personnel, under the stress of battle, to detect, acquire, and track typical targets.

(U) The recommendation that REDEYE development be preceded by supporting research to corroborate the validity of the proposed design and performance parameters was never implemented precisely as intended by the evaluation committee. Convair objected to the approach on the grounds that it had already performed exhaustive research in its corporate-funded studies. The driving force in the final decision, however, was the Marine Corps, which performed an evaluation of its own and insisted that the weapon was ready for development. Having \$1 million in R&D funds to spend or lose, the Marine Corps asked the Army to use it to begin REDEYE development.¹¹

¹¹ (1) Intvw, M. T. Cagle w Francis W. DuVall, 26 Feb 73. (Mr. DuVall either chaired or participated in all evaluations of weapon systems at Redstone Arsenal during the 1950's. When interviewed, he was assigned as Chief, ABM Concepts Studies Office, Systems Research Directorate, RDE&MSL.) (2) SAM Def Fundamentals Presn by Francis W. DuVall, 2 Feb 59, p. 1. Hist Div File. (3) REDEYE Dev Test Plan, ARGMA TP-9, 15 May 60, p. 8. RHA Bx 14-209.

(U) The next step, then, was to determine the availability of facilities and the probability of successful development and initial production of the REDEYE. Investigation revealed that Convair had considerable experience in missile development as a Navy contractor; that its Navy-owned, contractor-operated plant at Pomona, California, was producing at about 50 percent capacity; and that the Navy was agreeable to the Army's use of the facility for REDEYE development and possible production.¹²

Establishment of the REDEYE Project

(U) Pursuant to authority granted by the Assistant Secretary of the Army (Logistics), on 17 January 1958, Contract DA-04-495-ORD-1202 was awarded to Convair/Pomona on 14 April 1958,* for a 1-year feasibility study and demonstration of the REDEYE missile system under a program sponsored jointly by the U. S. Army and Marine Corps. Two months later, in June 1958, the REDEYE project was officially established with LA priority and the scope of work under the contract was increased to include design and development effort on the rocket motor and airframe. As noted earlier, the Marine Corps requested and funded this early development work, the use of Army funds (\$230,000) being confined to the feasibility study and supporting research. The total FY 1958 obligation for the Phase I feasibility study and initial development effort was

* The delay in negotiation of the contract stemmed from a complaint registered by North American Aviation upon learning that Convair's REDEYE system had been selected. A comparative analysis of the SLAM and REDEYE systems failed to change the committee's conclusions, however, and the Los Angeles Ordnance District was authorized to proceed with contract negotiations. Intvw, M. T. Cagle w Francis W. DuVall, 26 Feb 73.

¹² DF, Chf, REDEYE Sec, AD Br, RDD, to Chf, ARGMA Con Ofc, 8 Feb 60, subj: Cdr, ARGMA, DF Dtd 3 Apr 59 Concerning Prog Repts. Hist Div File.

\$1,580,000 in Army and Marine Corps funds.¹³

(U) Subsequent developments proved the evaluation team's findings to be remarkably prophetic. Despite the optimistic conclusions expressed in Convair's feasibility study report, most of the previously noted shortcomings and problem areas persisted throughout the Phase II development program. The task of guiding a rolling missile turned out to be much more difficult than expected; the seeker had to be improved even for minimum performance against typical targets; serious guidance problems were encountered in the area of background radiation; and structural redesign led to an 11-pound weight increase—from 18.2 to 29.3. As a result of these and numerous other problems, the R&D cost more than tripled the original (December 1958) estimate of \$23.9 million, and it took nearly 7 years to develop the interim REDEYE system, which finally reached the field in October 1967. The feasibility study and subsequent engineering development effort will be dealt with in appropriate detail following a brief review of the project management structure within the Redstone Arsenal complex.

¹³ (1) *Ibid.* (2) OTCM 36810, 12 Jun 58, subj: ADGM Sys (REDEYE) - Estb of Proj. RSIC. (3) REDEYE Msl Sys Plan, ARGMA MSP 8, 15 Feb 60, p. B-1. RHA Bx 14-209. (4) REDEYE Program Est, atchd as incl to DF, CofOrd to CRD, DA, 31 Dec 58, subj: ADGM Sys, REDEYE. Hist Div File.

CHAPTER II

(U) PROJECT MANAGEMENT STRUCTURE

Throughout its history, the REDEYE project was endowed with progressively effective command and management systems that assured coherent guidance, clearly defined command channels, responsive local controls, and competent technical supervision. As each new management system took shape in major command reorganizations, there were the usual disruptions and frustrations; however, the REDEYE project generally managed to retain enough of its experienced personnel to assure continuity of operation. The summary which follows traces the basic management structure as it evolved at Redstone Arsenal during the 1958-73 period. The contractual structure and problems stemming from the lack of adequate fiscal support will be treated in later chapters.

Formation of the Project

With approval of the REDEYE feasibility study program, in January 1958, the Chief of Ordnance assigned to Redstone Arsenal the national mission responsibilities for the project, which included research and development, procurement and production, industrial engineering, and industrial mobilization. The Arsenal Commander promptly established a REDEYE Section under the Surface-to-Air Missile (SAM) Branch of the R&D Division, and appointed Mr. Charles A. Cockrell as the project director.¹ Two months

¹(1) Intvw, M. T. Cagle w Charles A. Cockrell, 22 Feb 73. (Mr. Cockrell remained with the REDEYE program until March 1961, serving as project director until December 1958 and as the deputy director thereafter.) (2) Ltr, CG, RSA, to CG, CONARC, *et al.*, 11 Mar 58, subj: REDEYE Feasibility Dmstn Program. Hist Div File.

later, while negotiation of the feasibility study contract was still in progress, Redstone Arsenal underwent a general reorganization and the REDEYE project was placed under a new management system.

The AOMC/ARGMA Era—1958-61

On 31 March 1958, the Department of the Army (DA) created the U. S. Army Ordnance Missile Command (AOMC) at Redstone Arsenal and appointed as its head MG John B. Medaris. Placed under General Medaris' direct control were the Army Rocket & Guided Missile Agency (ARGMA), the Army Ballistic Missile Agency (ABMA), the Jet Propulsion Laboratory, the White Sands Proving Ground (later renamed White Sands Missile Range), and the Redstone Arsenal. Officially established on 1 April 1958, ARGMA assumed responsibility for the REDEYE project and other technical missions formerly assigned to Redstone Arsenal, leaving the latter with post support functions.²

The integration of primary research, development, test, and logistical support installations under single direction, together with the administrative streamlining, provided the means to carry out more effectively the existing and future Army missile programs. (See Chart 1.) Under the executive control of the Chief of Ordnance, AOMC was charged with the execution of Army rocket and guided missile programs, from the inception of an idea through research, development, production, procurement, and training, to supply, maintenance, and support in the field. Although not directly involved in operational matters, the AOMC Commander, as the weapon system manager, was concerned with whatever pertained to rockets and guided missiles, regardless of the service within the Army

²(1) DA GO 12, 28 Mar 58. (2) OrdC Order 6-58, 31 Mar 58.
(3) AOMC GO 6, 1 Apr 58.

CHART 1

USAOMC CHAIN OF COMMAND
March 1958 — July 1962

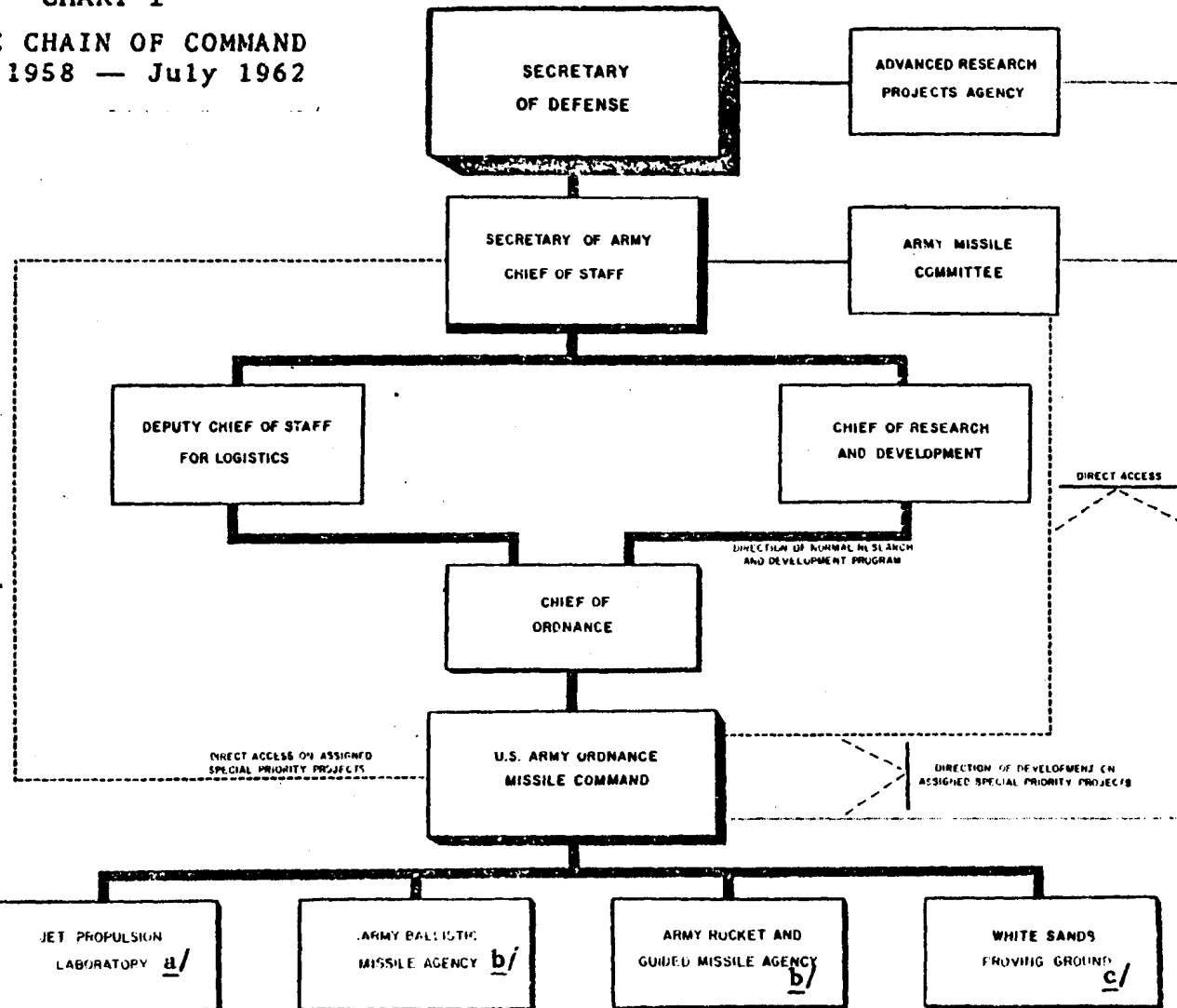

a. Reasgd to NASA, 3 Dec 58 (TT, CoFOrd to CG, AOMC, 3 Dec 58).

b. Abolished/merged with AOMC Hq 11 Dec 61 (AOMC GO 96, 5 Dec 61; DA GO 47, 26 Dec 61).

c. Renamed WSMR, 1 May 58 (DA GO 14, 19 Apr 58); Reasgd to OCO 1 Jan 62 (Ord Corps Order 16-58, Ch 5, 24 Nov 61).

that might be directly interested.³

During the 1958-61 period, ARGMA, as the commodity manager under command of AOMC, guided the REDEYE project through the Phase I feasibility demonstration and the first 29 months of engineering development. The REDEYE project activities were directed and coordinated through the Agency Control Office by a Senior ARGMA Representative (SXR) at the contractor's plant and designated representatives in the three national mission operations.⁴

With the commencement of REDEYE development in July 1959, the Control Office set up a resident office at the Convair/Pomona plant and appointed MAJ John G. Ransier as the SXR. When Convair began development of the MAULER weapon system in March 1960, additional ARGMA personnel were placed in residence there and Major Ransier became the SXR for the MAULER as an additional duty.⁵

Mr. Charles A. Cockrell continued to serve as the REDEYE project director in R&D Operations until December 1958, when the Commanding General of AOMC directed that such positions be filled with military personnel. MAJ Thomas F. McGraw, Jr., a U. S. Marine Corps officer already assigned to the REDEYE Section, took over the

³ OrdC Order 16-58, 1 Jul 58, subj: Msn of the AOMC.

⁴ (1) ARGMA Cir 7 (later renumbered 600-1), 28 Jun 58, subj: ARGMA Ln Pers at Contrs' Plants & Govt Instls, as amended 19 Jun 59. (2) ARGMA Cir 16, 19 Sep 58, subj: Sys Proj Resp (reissued as Cir 1-2, 4 Jun 59, with no change in content). The latter was superseded by Cir 1-2, 12 May 60, subj: Agcy Cmdty Coord. See ARGMA Hist Sum, 1 Jan 60 - 30 Jun 60, pp. 15-19.

⁵ (1) DF, Cmt 2, Chf, Con Ofc, to Chf, Indus Div, 9 Jul 59, subj: Asgmt of ARGMA Rep to REDEYE Program. (2) DF, Chf, Projs Ofc, ARGMA Con Ofc, to SXR, Firestone-Gilfillan Ofc, Los Angeles, Calif., 17 Nov 59, subj: Asgmt of Auth & Resp to SXR for REDEYE & SHILLELAGH Msl Sys. (3) DF, Chf, Projs Ofc, ARGMA Con Ofc, to Civ Pers Ofc, 2 Feb 60, subj: The Estb of SXR Ofc at the Aeronutronics Plant & Convair. (4) Ltr, Cdr, ARGMA, to CO, LAOD, 22 Mar 60, subj: Asgmt of ARGMA Fld Rep. All in Hist Div File.

director's job on 1 December 1958 and served until 19 July 1959. He was succeeded by MAJ Henry L. Claterbos, another Marine Corps officer. Major Claterbos was promoted to lieutenant colonel on 16 November 1962 and remained with the project until mid-1964.⁶ The REDEYE project officers in the other national mission operations and Control Office were Mr. Fred Sittason (Control), Mr. J. R. Turner (Industrial), and MAJ F. C. Keller and CPT H. W. Strohm (Field Service).⁷

In view of the magnitude of development problems and schedule slippages experienced during 1960-61, the number of civilian manpower spaces allocated to the REDEYE project was surprisingly small. As of 30 September 1961, the equivalent of 18 manpower spaces were charged to the REDEYE (15 in the national mission operations and 3 in the Control Office). In contrast, the MAULER project had 79 manpower spaces, the HAWK had 543, the NIKE HERCULES had 843, and the NIKE AJAX had 94.⁸

To assist the weapon system manager in the decision-making and coordination process, the Commanding General of AOMC, in early 1960, established a REDEYE Steering Committee. MAJ Henry L. Claterbos represented ARGMA as a member and Mr. Charles A. Cockrell was the recorder. The committee held its first meeting on 10 May 1960.⁹ This was followed, in November 1961, by the creation of a REDEYE Technical Coordinating Committee at ARGMA to assist the commodity manager in the coordination and timely dissemination of

⁶ (1) Intvw, M. T. Cagle w Charles A. Cockrell, 22 Feb 73.
(2) Roster of Officers, May 64 & Sep 64. Hist Div File.

⁷ List of Proj Offs by Wpn Sys Proj, 30 Jun 60 & 1 Aug 60. Hist Div File.

⁸ ARGMA Rept, Civ Mpr Allocn by Msl Sys as of 30 Sep 61. Hist Div File.

⁹ (1) DF, Chf, Review Br, ARGMA Con Ofc, to CG, AOMC, 13 Jan 60, subj: Estb of REDEYE Steering Com. Hist Div File. (2) AOMC Hist Sum, 1 Jan 60 - 30 Jun 60, p. 40.

of data to those agencies participating in the technical aspects of the program. It was chaired by MAJ Henry L. Claterbos and consisted of representatives from the ARGMA Industrial and Field Service Operations, White Sands Missile Range, Chief of Ordnance, Naval Ordnance Test Station, Picatinny Arsenal, Ballistic Research Laboratories, and Human Engineering Laboratories.¹⁰

In the AOMC reorganization of 11 December 1961, ARGMA and its sister agency, ABMA, were abolished and their functions merged with AOMC Headquarters.¹¹

The MAULER-REDEYE Project Office

Under the new AOMC organizational structure, which became operational on 1 January 1962, the national and support missions of the former ARGMA and ABMA were consolidated and assigned to the R&D, Industrial, and Field Service Directorates. Established under the Commanding General were Deputy Commanding Generals (DCG's) for the two missile system groups—ballistic missiles and guided missiles. The MAULER-REDEYE Project Office was established under the DCG for Guided Missiles (DCG/GM) effective 12 December 1961.¹² At the same time, COL B. J. Leon Hirshorn became the MAULER-REDEYE Project Manager,¹³ with responsibility for directing and coordinating the project activities assigned to and performed by the national

¹⁰ Ltr, Cdr, ARGMA, to CofOrd, *et al.*, 2 Nov 61, subj: Estb of REDEYE Tech Coord Com. Hist Div File.

¹¹ (1) AOMC GO 96, 5 Dec 61. (2) DA GO 47, 26 Dec 61.

¹² (1) Ltr, CG, AOMC, to CofOrd, *et al.*, 29 Dec 61, subj: Reorg of the USAOMC. Hist Div File. (2) AOMC GO 96, 5 Dec 61, as amd by AOMC GO 30, 14 Mar 62. (The latter order changed the organizational designation of the Project Office to Project Manager.) (3) The DCG/GM was later renamed and is hereafter referred to as the DCG for Air Defense Systems (DCG/ADS). MICOM GO 43, 3 Oct 62.

¹³ AOMC GO 99, 13 Dec 61.

CHART 2
US ARMY ORDNANCE MISSILE COMMAND

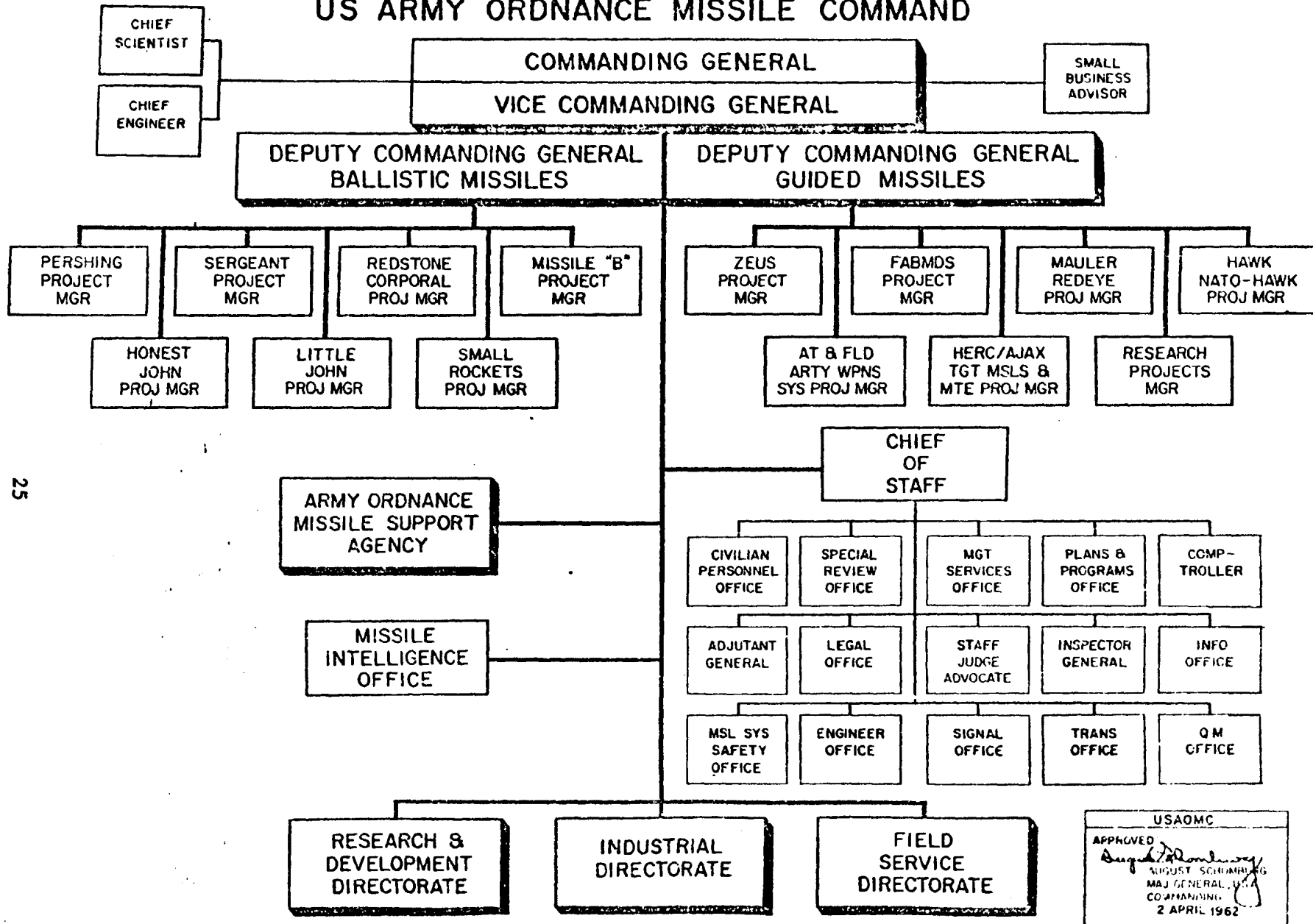

25

USAOMC
APPROVED
August Schmitt
AUGUST SCHMITT
MAJ GENERAL, USA
COMMANDING
2 APRIL 1962

mission directorates and supporting services.¹⁴

Mr. Lewis L. Gober replaced Colonel Hirshorn as acting project manager on 13 June 1962.¹⁵ As of 30 June 1962, the DCG/ADS and his 7 project offices, including the MAULER-REDEYE, had a total assigned strength of 75 personnel. Only three of these were allotted to the REDEYE, indicating no improvement over the previous ARGMA Control Office project staff.¹⁶

The REDEYE Commodity Office—1962-64

The AOMC reorganization extended into 1962, overlapping a major Army reorganization which culminated in the creation of the Army Materiel Command (AMC), the abolition of the Office, Chief of Ordnance (OCO), and the realignment and redesignation of AOMC as the Army Missile Command (MICOM). The new AMC and MICOM organizations existed with skeleton staffs from 23 May to 1 August 1962, when they became operational. AMC absorbed the functions of the former OCO, and MICOM absorbed functions of the former AOMC.¹⁷

In the AOMC realignment, the MAULER project was reorganized in accordance with the AMC concept of centralized or vertical management, while the REDEYE project continued to operate under the decentralized management system as a product (commodity) office. Among the criteria considered in the selection of a weapon system for project managership were: the need for

¹⁴ AOMC Org Manual, 26 Jan 62, Sec 380.

¹⁵ AOMC GO 78, 5 Jul 62.

¹⁶ (1) AOMC Pers Sta Rept, 30 Jun 62. Hist Div File. (2) Intvw, M. T. Cagle w Fred Sittason, 2 Mar 73. (3) *Also see* above, p. 23.

¹⁷ (1) DA GO 23, 4 May 62. (2) AMC GO 4, 23 May 62. (3) DA GO 46, 25 Jul 62. (4) MICOM GO 5, 30 Jul 62. (5) DA GO 57, 27 Sep 62. (6) For a detailed history of the reorganization, *see* AOMC Hist Sum, 1 Jan - 30 Jun 62; MICOM Hist Sum, FY 1963; & AMC Hist Sum, FY 1963.

accelerating the decision-making process; significant interest in the system expressed by the Congress, the President, or the Secretary of Defense; the essentiality of the item to the Army mission; and the high dollar value of the system, or the presence of major managerial and technical problems. These problems might involve such factors as slippages in production or significant deficiencies revealed in user tests.¹⁸ At the time of the AOMC reorganization, in 1962, both the MAULER and REDEYE projects were in very deep trouble and both met virtually all of the criteria for special management.¹⁹ Ironically, the MAULER project eventually was terminated despite its special management status, while the REDEYE struggled to escape the same fate as a commodity office.

The REDEYE Product Office was established under the DCG/ADS effective 31 July 1962,²⁰ and was redesignated as the REDEYE Commodity Office on 22 October 1962.²¹ Mr. Lewis L. Gober served as the Acting REDEYE Product (Commodity) Manager from 1 August 1962 until the assignment of COL Norman T. Dennis on

¹⁸Raymond J. Snodgrass, *The Concept of Project Management* (AMC Hist Ofc, 1964), pp. 89, 92.

¹⁹For example, because of continuing technical problems, the scheduled completion of the REDEYE development program had been delayed from 1961 to 1965; initiation of the industrial effort had been deferred on a year-by-year basis from FY 1960 to FY 1964; the estimated development cost had increased from the original projection of \$23.9 million to nearly \$61 million, about \$27.3 million of that sum having been spent through FY 1962; and, as more was learned about the weapon, the estimated unit cost of production systems continued to increase. (1) DF, Chf, AOMC Con Ofc, to Distr, 6 Dec 60, subj: Mins of REDEYE Wpn Sys Mgr's Rept. (2) Sum of CRD/C MFR, 12 Oct 62, subj: Rept of Mtgs, DDRE Ad Hoc Gp on REDEYE. (3) DF, C&DP to REDEYE Prod Mgr, 24 Oct 62, subj: DA/AMC Staff Review of REDEYE, AMCP, w incl: Detailed Data for AMCP Prepn. (4) R&D Anal for REDEYE Program, atchd as incl to DF, R&D Dir to REDEYE Cmdty Mgr, 14 Feb 63, subj: R&D Anal - REDEYE. All in Hist Div File.

²⁰(1) AOMC GO 87, 30 Jul 62. (2) MICOM GO 5, 30 Jul 62.

²¹MICOM GO 54, 5 Nov 62.

20 November 1962.²² In the ensuing 14 months, Colonel Dennis and a very small civilian staff saw the basic REDEYE system through solutions to the stubborn technical problems that had plagued the contractor from the inception of development, and on to early studies leading to the advanced REDEYE II system later to be known as the STINGER. Initially, the REDEYE Commodity Office was authorized three civilians and had an assigned strength of two. By 30 June 1963, the personnel authorization had been increased to six, and there were five assigned. On 31 December 1963, the office was up to full strength with a staff of six civilians.²³

Mr. Ernest K. Charlton succeeded Colonel Dennis as Acting REDEYE Commodity Manager on 29 January 1964.²⁴ Two months later, the REDEYE was elevated from commodity to project management status.

The REDEYE Project Office—1964-71

The Office of the REDEYE Project Manager was established at MICOM Headquarters on 1 April 1964,²⁵ some 10 days before the award of the first production contract, which had been delayed for 4 years because of technical difficulties in meeting certain military characteristics. The concept of vertical project management recognized the project manager as the single individual responsible for accomplishing the objectives of his assigned program. Specifically, the project manager was charged with exercising full-line authority over all planning, direction, and control of tasks and

²² (1) MICOM GO 15, 7 Aug 62. (2) MICOM GO 61, 27 Nov 62. (3) This was an additional duty for both Mr. Gober and Colonel Dennis, their primary duty assignment being as the MAULER Project Manager.

²³ MICOM Pers Sta Repts, 31 Dec 62, 30 Jun 63, & 31 Dec 63.
Hist Div File.

²⁴ MICOM GO 10, 30 Jan 64.

²⁵ MICOM GO 22, 18 Mar 64.

associated resources involved in furnishing REDEYE systems and system support to the intended operational destination. This included all phases of research, development, test, procurement, production, distribution, and logistic support for the purpose of maintaining a balanced program to accomplish the stated objectives of AMC.²⁶

Unlike the older project offices, the REDEYE Project Office was organized according to the refined MICOM project management policy, which decreed that such offices would consist of small groups of elite management technicians who would rely on the functional directorates to accomplish the "doing" portions of the project work, with the project manager retaining full-line authority for planning, direction, and control of the total effort.²⁷ The REDEYE Project Manager was initially allotted a total of 37 personnel spaces (3 officers; 34 civilians),²⁸ which were to be filled through normal manpower channels.²⁹

The task of staffing the expanded organization with competent management and engineering talent initially fell to Mr. Ernest K. Charlton, who served as the Acting REDEYE Project Manager from 1 April 1964 until COL Arthur W. Reed's arrival on 23 July 1964.³⁰

²⁶ MICOM Org Manual, Sec 175, 9 Jun 64.

²⁷ Handbook, Proj Mgr/Dir Funcl Relationships, 15 Sep 65. Hist Div File.

²⁸ MICOM Pers Sta Rept, 30 Jun 64. Hist Div File.

²⁹ (1) MICOM GO 22, 18 Mar 64. (2) The older project offices, such as the NIKE HERCULES, HAWK, and SERGEANT, had secured the bulk of their staff by the transfer of project-oriented personnel from the functional directorates. With implementation of the refined management policy, however, the staffing level of these offices was drastically reduced as many of the functions, personnel, and personnel spaces were sent back to the functional directorates. For example, the HERCULES Project Manager's manpower authorization dropped from 235 to 111. MICOM Pers Sta Repts, 30 Jun 65 & 30 Jun 66.

³⁰ (1) MICOM GO 22, 18 Mar 64. (2) AMC SO 103, 24 Jul 64.

APPROVED:
DATE 9 JUN 64
[Signature]
JOHN C. HENRY
MAJOR GENERAL
COMMANDING

CHART 3
US ARMY MISSILE COMMAND
REDEYE PROJECT MANAGER

30

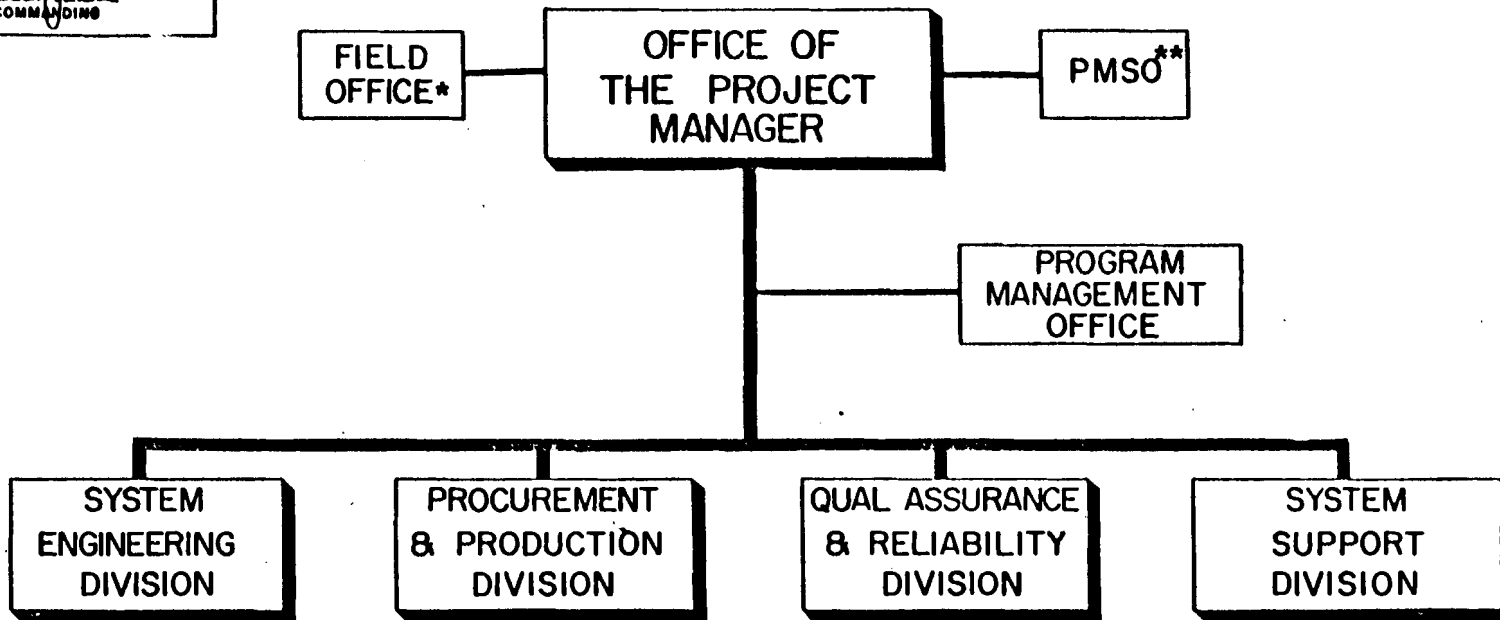

* At General Dynamics/Pomona (Prime Contractor).

** Project Management Staff Officer, AMC Headquarters.

CHART 4 HEADQUARTERS, U.S. ARMY MISSILE COMMAND

APPROVED:
DATE 29 JAN 65
[Signature]
JOHN G. TENDY
MAJOR GENERAL
COMMANDING

COMMODITY OFFICES *

AIR DEFENSE
- MTE
- TARGET MISSILES
- DIVISION AIR DEFENSE
SYS/FAIR WEATHER
SAM-D (AADS-70's)**
AJAX **

LAND COMBAT
-MAW -HONEST JOHN
-M-22 -LITTLEJOHN
-ENTAC -CORPORAL **
-XM-3 -REDSTONE **

COMMANDING GENERAL
DCG, AIR DEFENSE SYSTEMS
DCG, LAND COMBAT SYSTEMS
CHIEF OF STAFF

PROJECT MANAGERS *

LANCE	MAULER
SERGEANT	HAWK/NATO HAWK
PERSHING	HERCULES
TOW	REDEYE
SHILLELAGH	

**COMPTROLLER & DIRECTOR
OF PROGRAMS**

31

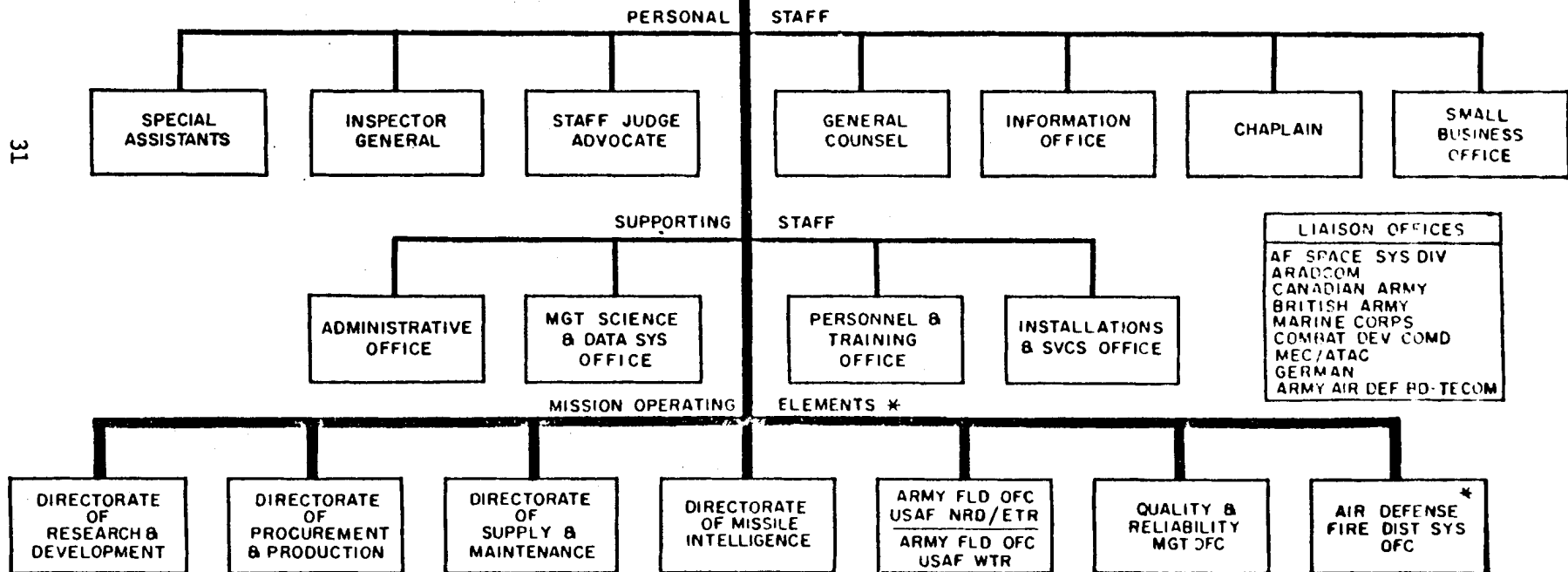

* PROJECT MANAGERS, AIR DEFENSE FIRE DISTRIBUTION SYSTEMS OFFICE, AND COMMODITY OFFICES/MISSION OPERATING ELEMENTS, ARE ON THREE SEPARATE TABLES OF DISTRIBUTION.

** SURF TO AIR MSL / DEV (AADS-70's) MANAGED BY DIRECTORATE OF RESEARCH & DEVELOPMENT; AJAX MANAGED BY HERCULES PROJECT MANAGER; CORPORAL & REDSTONE MANAGED BY DIRECTORATE OF SUPPLY & MAINTENANCE

By 15 July 1964, the office staff had grown from a skeleton crew of 6 to 27 (2 officers; 25 civilians).³¹ In the next 12 months, the project manager gained 14 personnel, pushing his assigned strength to 41, 4 more than authorized.³² Included in his staff and charged against the Table of Distribution (TD) were three personnel assigned to the REDEYE Field Office at General Dynamics/Pomona. Mr. Asa Edens, the Senior REDEYE Representative, had full authority for all required on-site actions and provided the contractor with technical direction and guidance to assure timely and economical development, production, and fielding of the weapon system.³³

During the last half of FY 1966, the TD authorization was increased from 37 to 66 (3 officers; 63 civilians), and at the end of that fiscal year the office had 59 personnel (5 officers; 54 civilians).³⁴ The peak authorized and actual personnel strength was reached with initial deployment of the REDEYE in FY 1968, the former being increased to 68 (3 officers; 65 civilians) and the latter to 67 (3 officers; 64 civilians).³⁵

With Colonel Reed's retirement, Mr. Charlton again took over as acting project manager on 1 June 1967.³⁶ COL John R. M. Covert became the REDEYE Project Manager on 21 August 1967³⁷ and remained on the job through deployment of the weapon system. He was succeeded, on 14 July 1969, by LTC William L. Rehm,³⁸ who steered

³¹ MICOM Pers Sta Rept, 15 Jul 64. Hist Div File.

³² *Ibid.*, 30 Jun 65.

³³ (1) List of MICOM Fld & Ln Ofc Pers, 11 May 65. (2) MICOM Org Manual, Sec 175, 9 Jun 64.

³⁴ MICOM Pers Sta Rept, 30 Jun 66. Hist Div File.

³⁵ *Ibid.*, 31 Dec 67 & 30 Jun 68.

³⁶ AMC Msg 66469, 31 May 67.

³⁷ MICOM GO 98, 24 Aug 67.

³⁸ MICOM GO 67, 11 Jul 69.

the REDEYE program through the gradual phasedown of operations preparatory to deprojectization, and the transition to the special items/functional management concept under the new standard commodity command structure. At the end of December 1969, the project manager's authorized strength had dropped to 62 (3 officers; 59 civilians), and his assigned strength to 58 (2 officers; 56 civilians).³⁹

In October 1969, following a review of the management requirements of the program, MICOM recommended that the REDEYE be continued under project management with a decreased staffing level until September 1970, at which time a decision would be made relative to a follow-on system and continuation of the project office.⁴⁰ After a further review in January 1970, the Commanding General of MICOM, over objections of the project manager, recommended that the REDEYE be deprojectized on 30 June 1970, or concurrently with the realignment to the new commodity command structure. At the same time, he recommended that the NIKE HERCULES be converted to commodity management by 30 September 1971.⁴¹ However, the Secretary of the Army, with concurrence of AMC, removed both the REDEYE and HERCULES from project management status effective 27 April 1970,⁴² and the transition plan for deprojectization was forwarded to AMC early in June 1970.

The approved MICOM plans called for the establishment of a

³⁹ MICOM Pers Sta Rept, 31 Dec 69. Hist Div File.

⁴⁰ SS AMSMI-WM-149-69, Mgt Science & Data Sys Ofc, 24 Oct 69, subj: MFR's on MICOM Bfg to BG Guthrie, AMCRD, 9 Oct 69, & incl thereto. Hist Div File.

⁴¹ Ltr, CG, MICOM, to LTG Henry A. Miley, Jr., DCG, AMC, 14 Jan 70, n.s., & Incl 1 thereto, REDEYE Proj Fact Sheet, subj: Just for REDEYE Proj Mgt. Hist Div File.

⁴² Ltr, SA to CG, AMC, 27 Apr 70, subj: Termn of Proj Mgt for REDEYE and HERCULES. Hist Div File.

very small management office, to be known as the Air Defense Special Items Management Office (ADSIMO) and consisting of 15 civilians and 4 officers, to exercise overall management of the REDEYE and HERCULES systems after their deprojectization. The same plans provided for the creation of a new Systems Engineering & Integration Office in the Directorate for Research, Development, & Engineering, which, among other things, would be responsible for all system engineering on weapon systems under technical direction of ADSIMO.

During the transition period (April-December 1970), the REDEYE Project Manager continued to operate under his existing organizational structure. His operational concepts, however, were modified to follow more closely the concept of commodity management, and activities, reports, and other instruments or requirements directly connected to project management, as such, were discontinued. Pursuant to the transition plan, the REDEYE personnel authorization was reduced, in May 1970, from 62 (3 officers; 59 civilians) to 26 civilians. However, the assigned staff remained at a level of 28 (1 officer; 27 civilians) through 31 December 1970.⁴³

The Air Defense Special Items Management Office—1971-73

Effective 4 January 1971, the REDEYE and HERCULES Project Offices were officially discontinued and the new Air Defense Special Items Management Office was organized with an authorized strength of 4 officers and 15 civilians. At the same time, COL Morris W. Pettit was relieved as HERCULES Project Manager and

⁴³ (1) Rept of HERCULES/REDEYE Deprojectization Study Com, 28 May 70. (2) Ltr, DCG/ADS to REDEYE PM, 5 Jun 70, subj: Termn of Proj Mgt for REDEYE. (3) MICOM Pers Sta Repts, 30 Jun 70 & 31 Dec 70. All in Hist Div File.

assigned as the manager of ADSIMO, with responsibility for overall management of REDEYE and HERCULES activities and for providing control and coordination to assure full support by all functional directorates. In accordance with the approved MICOM reorganization plan and deprojectization study, selected personnel of the Systems Engineering & Integration Office of the restructured Directorate for Research, Development, Engineering, & Missile Systems Laboratory, were collocated with the ADSIMO staff.⁴⁴ COL Donald H. Steenburn succeeded Colonel Pettit as the manager of ADSIMO on 17 April 1972.⁴⁵

On 16 September 1973, the Air Defense and Land Combat Special Items Management Offices (ADSIMO and LCSIMO) were discontinued and their assigned weapon system management functions were transferred to the newly created Special Systems Management Office. COL Hal C. Bennett, Jr., chief of the former LCSIMO, was appointed chief of the new office.⁴⁶

⁴⁴MICOM GO's 22, 23, & 24, all dtd 1 Mar 71.

⁴⁵MICOM GO 60, 17 Apr 72.

⁴⁶MICOM GO 149, 12 Sep 73.

CHAPTER III

(S) FEASIBILITY STUDY PROGRAM (U)

(U) The Convair/Pomona Division of General Dynamics began the 1-year feasibility study in April 1958, under the technical direction of ARGMA. In addition to specified system studies, the project consisted of three separate test programs. The first dealt with the human aspects of the weapon system. The second covered target radiation tests to obtain the infrared radiation patterns of typical aircraft. The third program called for the flight test of 30 missiles to demonstrate the feasibility of the REDEYE guidance and control systems. Where practicable, the test vehicles used existing hardware, such as the 2.75-inch FFAR's for propulsion and SIDEWINDER seekers for guidance.

(U) All flight tests and radiation measurements were conducted at the Naval Ordnance Test Station (NOTS), China Lake, California. The use of this facility saved considerable time and expense in the conduct of both the feasibility demonstration and the subsequent development test program. NOTS, developer of the Navy's SIDEWINDER missile, offered excellent test facilities and trained infrared personnel within 100 miles of the contractor's plant at Pomona, allowing close scheduling of test firings. In addition, it had targets on the station to support the firing test program, and manned tactical aircraft were available for tracking tests and continued infrared radiation measurements with modified seeker designs. An additional factor in the choice of the test site was that the cost of contractor support at NOTS would be much less than the cost at a remote proving ground.

(U) In addition to the development work funded by the Marine

Corps, Picatinny Arsenal was authorized to conduct a feasibility study of a warhead and fuze of the size and weight allowable for the REDEYE, and the Human Engineering Laboratories at Aberdeen Proving Ground were funded to monitor the human factors tests. Also, arrangements were made for ARGMA's Ordnance Missile Laboratories (OML) to monitor and evaluate the contractor's infrared measurements and preliminary rocket motor design.¹ The FY 1958 R&D funds obligated for the Phase I feasibility study program and early development effort totaled \$1,580,000, all but \$230,000 of which was supplied by the Marine Corps.²

Human Factors Tests

(U) The objective of the human factors tests was to demonstrate the ability of Army and Marine Corps personnel to detect, acquire, and track typical targets and to fire the missile in time to exploit the design capabilities of the weapon. These tests were performed in May 1958 at Twenty-nine Palms and Camp Pendleton, California, using six simulators designed and constructed to simulate the REDEYE weapon as nearly as possible in weight, balance, appearance, and feel. The simulators were equipped with 16-mm. battery-operated cameras to record tracking accuracy and time of fire. A light bulb, operated by the trigger and located at the forward end of the tube in the camera field of view indicated the time of fire. Camera activation was controlled by a squeeze switch on the rear grip. The F-9F and FJ-4 single engine jets were used in most of the tests; however, some data

¹(1) REDEYE Msl Sys Plan, ARGMA MSP 8, 15 Feb 60, pp. B-1, B-2, D-8. RHA Bx 14-209. (2) Convair Rept, REDEYE Feasibility Program Final Rept, 30 Jun 59, p. 1. RSIC.

²REDEYE Program Est, atchd as incl to DF, CofOrd to CRD, DA, 31 Dec 58, subj: ADGM Sys, REDEYE. Hist Div File.

UNCLASSIFIED

~~CONFIDENTIAL~~

were obtained with the T-28, TV-2, and F-102 aircraft. The targets flew standard flight courses at speeds of 160 to 620 knots and at altitudes of 20 to 10,000 feet.

(U) The test results confirmed that service personnel could properly acquire and track the target and fire the missile, and that detection ranges were adequate. According to the test report, the probability of personnel effectively launching the missile in time to exploit the design capabilities of the REDEYE exceeded 95 percent. In a random sample of 167 target runs—about 20 percent of all available film—100 percent were successfully fired at either incoming or outgoing targets, with success being achieved in 89.8 percent of the incoming shots attempted and in 98.8 percent of the outgoing shots attempted.³

Target Radiation Tests

(U) Convair conducted the target radiation tests at NOTS during the period 2 June through 15 July 1958. The basic types of aircraft used in the tests were as follows:

F9F-6K and A4D single engine jets
F3D, A3D, and F2H twin engine jets
JD-1 and R5D multi-engine reciprocating aircraft
HUS-1 helicopter

(U) The overall results of the tests indicated that typical military targets, including jet engine and reciprocating engine aircraft, radiated enough energy in the portion of the spectrum used by the REDEYE to provide seeker with sufficient signal for predicted performance for incoming and outgoing targets. Radiation measurements of various tactical aircraft indicated that

³(1) REDEYE Dev Test Plan, ARGMA TP-9, 1 Feb 60, p. 8. RHA Bx 14-209. (2) Convair Rept, REDEYE Feasibility Program Final Rept, 30 Jun 59, pp. 3-7, 9. RSIC.

~~CONFIDENTIAL~~

UNCLASSIFIED

UNCLASSIFIED

~~CONFIDENTIAL~~

production model seekers would be able to achieve head-on ranges of about 1,500 meters and tail-chase ranges in excess of 5,000 meters against single engine jet aircraft. Background radiation tests showed possibilities of increasing ranges in excess of 5,000 meters against single engine jets by reducing the field of view of the seeker and improving the reticle (chopper) design.⁴

Flight Tests

(U) As originally planned, the flight test phase of the feasibility demonstration program consisted of the fabrication and testing of 30 missiles to obtain design and performance information on the guidance and control systems. Ten of these missiles were to be Launch Test Vehicles (LTV's) with dummy guidance sections, and 20 were to be Guidance Test Vehicles (GTV's) with modified SIDE-WINDER seekers. However, the program objectives were accomplished with nine LTV's and nine GTV's. The remaining missiles were retained for use in support of the Phase II R&D program.

LTV Firings

(U) The LTV firing program began at NOTS on 27 June and continued through 28 November 1958. The purpose of the firings was to study the tail fin and control surface configurations and to establish flight characteristics. The LTV's were equipped with 2.75-inch FFAR Aeromite motors, dummy nose sections, and various tail fin configurations to study missile stability and roll rate. All nine rounds were launched at a 15° elevation from the LTV launcher, which was mounted on one arm of an MSG-3 TERRIER missile launcher.

(U) Supplementing the LTV firings was a series of Tail Test

⁴(1) *Ibid.*, pp. 10-17. (2) REDEYE Dev Test Plan, ARGMA TP-9, 1 Feb 60, p. 8. RHA Bx 14-209.

~~CONFIDENTIAL~~

UNCLASSIFIED

UNCLASSIFIED

~~CONFIDENTIAL~~

Vehicle (TTV) firings, in September 1958, to resolve a problem of instability in the transonic speed region. From these tests, the tail design was established for the best compromise between stability and maneuverability, and this design was used in subsequent LTV and GTV flight tests. Among the objectives reportedly achieved in the LTV flight test program were (1) the establishment of a tail fin configuration providing the required stability margin and roll rate; (2) verification of aerodynamic studies and wind tunnel data; and (3) evaluation and acceptance of the FFAR Aeromite rocket motor as satisfactory for the GTV flight test program.⁵

GTV Firings

(U) The purpose of the GTV firings was to demonstrate the feasibility of the complete REDEYE system concept, with primary emphasis on the guidance and control scheme. The missile consisted of a 2.75-inch FFAR motor with modified tail fins and igniters; a power supply section, consisting of a hermetically sealed thermal battery produced by the Eureka-Williams Company; a control section; an electronics section; and a modified SIDE-WINDER IR seeker. The launching equipment consisted of an M-45 machine gun mount modified to accommodate the GTV launcher (a motor driven, rolling launch tube) and a Mitchell camera for boresight camera coverage.

(U) The seeker consisted of a combination telescope and permanent magnet gyro, concentric control coils, detector cell, and an amplifier/tracking loop combination. The Cassegrainian telescope*

* Invented by N. Cassegrain, a 17th-century French physician and inventor, the Cassegrainian telescope is a reflecting telescope in which a concave primary mirror reflects incident light to a convex secondary mirror that in turn reflects the light back through a central perforation in the primary and onto the focal plane.

⁵Convair Rept, REDEYE Feasibility Program Final Rept, 30 Jun 59, pp. 24-30. RSIC.

~~CONFIDENTIAL~~

UNCLASSIFIED

UNCLASSIFIED

~~CONFIDENTIAL~~

focused target infrared energy through a filter on the chopper, which rotated with the optical elements as part of the gyro. The chopper modulated the target energy as a function of tracking error. The target energy was then converted to an electrical signal by the PbS (lead sulfide) cell. This signal was amplified and rectified to recover the gyro spin frequency modulation, which was then compared in a phase demodulator to the reference coil output to obtain the control signal. With the missile rolling, the phase-demodulator output was a sine wave whose phase (relative to missile roll angle) indicated target direction, and whose magnitude was proportional to the angular rate of the line of sight.

(U) The control surfaces for the missile were a pair of fixed-incidence, retractable, canard surfaces located just aft of the seeker head. To produce lift, the surfaces were extended during one angular sector (called the lift sector) of each roll cycle. (The missile was forced to roll throughout the flight by means of canted tail surfaces.) The width of the lift sector determined the magnitude of the maneuver, and its timing determined the direction. Although the wings were driven in and out in "bang-bang" fashion, control of the width of the called-for lift sector in the autopilot gave approximately proportional control of the missile. The drive mechanism for the canards was a crossbar and sector gear assembly actuated by a linear motion solenoid.

(U) The GTV firings began at NOTS on 11 March 1959. Targets for the flight tests were flares, suspended from tethered balloons, at an altitude of 1,500 feet. The target range was 4,000 feet for the first six rounds and 3,500 feet for the last three rounds.

(U) In the first five flight tests, conducted on 11 and 16 March 1959, all but one of the rounds showed evidence of guidance; however, major flight problems were encountered. There was excessive seeker noise at launch on all of the five flights, and missile roll rates were much lower than predicted on four of them.

~~CONFIDENTIAL~~

UNCLASSIFIED

(Roll rate was not obtained on the other.) Three of the rounds missed the target by an excessively wide margin. (Miss distance was not recorded for the other two.) A potential problem of seeker discrimination between target radiation and background radiation showed up in GTV 5, which exhibited no evidence of guidance toward the target, but appeared to be controlled and possibly homed on a horizon hot spot.

(U) To allow time for modification and instrumentation of the remaining missiles, the performance time under the Phase I contract was extended to 30 November 1959 with no increase in cost. The source of the seeker noise was traced to the first stage of the small signal amplifier, where three carbon resistors were found to be microphonic. To reduce the vibration-induced seeker noise to a tolerable level, the resistors on Rounds 6 through 9 were replaced with low-noise carbon film resistors. Other design changes included a slightly higher tail cant angle to increase the missile roll rate; higher bias (lower system sensitivity) in the autopilot; and stronger retraction springs in the wing solenoid actuator to improve missile control.

(U) The GTV firings were resumed with the sixth flight test on 8 June 1959. The initial roll rate for this round coincided with predicted values; however, camera coverage was lost shortly after launch and missile in-flight performance could not be evaluated. Rounds 7, 8, and 9, launched on 17 June 1959, were completely successful. All phases of the flights were excellent, with miss distances of 10, 25, and 15 feet, respectively.⁶ Convair concluded that the "successful performance of GTV's 7, 8, and 9 proved that the basic design of the REDEYE guidance

⁶(1) *Ibid.*, pp. 31-34, 39, 41-42, 104. (2) REDEYE Dev Test Plan, ARGMA TP-9, 1 Feb 60, p. 8. RHA Bx 14-209. (3) REDEYE Prog Rept, Nov 59, pp. 1, 3. RHA Bx 14-209.

~~UNCLASSIFIED~~

~~CONFIDENTIAL~~

system was sound and further substantiated the concept of the rolling-missile form of guidance."⁷

Establishment of Military Characteristics

Meanwhile, the joint Army-Marine Corps statement of military characteristics (MC's) for the REDEYE weapon system was submitted to the Ordnance Technical Committee in December 1958 and approved by the Secretary of the Army on 19 February 1959. The shoulder-fired REDEYE system, together with the self-propelled MAULER missile system which was then in the proposal evaluation stage, represented the proposed solution to the forward area, low-altitude air defense problem. The REDEYE MC's specified a requirement for an all-arms antiaircraft weapon for defense against low-flying aircraft in areas not adequately protected by organic air defense elements. Specifically, the REDEYE was to be designed for use against tactical aircraft (both piloted and pilotless), reconnaissance drones, and light aviation of both fixed and rotary-wing type, with operational capabilities as follows:

Speeds. At all speeds up to 600 knots.

Altitudes. At all altitudes up to 9,000 feet when flying singly or in close formation.

Horizontal Ranges. At all horizontal ranges up to 4,500 yards.

⁷ (1) Convair Rept, REDEYE Feasibility Program Final Rept, 30 Jun 59, p. 42. RSIC. (2) The extended phase of the feasibility flight tests ended on 20 November 1959, after the firing of six more GTV rounds against OQ-19 drones with remotely ignited T121 tracking flares attached. Rounds 10, 11, and 12 showed no evidence of guidance; Rounds 13 and 14 indicated evidence of guidance, but missed their targets by 20 and 26 feet, respectively; Round 15 achieved a close miss distance of less than 6 feet. REDEYE Prog Rept, Nov 59, pp. 1, 3-4. RHA Bx 14-209.

~~CONFIDENTIAL~~

~~UNCLASSIFIED~~

UNCLASSIFIED

~~CONFIDENTIAL~~

Target Maneuver. While executing maneuvers up to 6 g's within specified speeds, altitudes, and ranges.

The effectiveness of the system against the specified targets was to be such as to achieve a single shot kill probability (SSKP) of 0.5. The lethality of the warhead was to be that required to attain the desired effectiveness against a target whose vulnerability was that normally associated with a single-engine, jet-powered, armored aircraft. Provision was to be made for a contact-delay fuze which would detonate after piercing the target's outer skin. The reliability of the weapon system, to include the missile, was to be a minimum of 90 percent.

(U) The size, weight, and configuration of the system was to be such as to permit its transport and operation by one man. The combined weight of the missile and launcher assembly was not to exceed 20 pounds. The propulsion system was to consist of a solid propellant, with no motor alignment or adjustments required of firing personnel. Upon acquisition of the target (missile lock-on), a suitable signal, originating within the missile, would be provided the operator, signifying that the weapon could be fired. Since the REDEYE system was not envisioned to have a detection, identification, and acquisition capability other than the human eye, some form of target identification and/or weapon traffic control was required. Among other essential system capabilities were these:

A radial dead area about the weapon of not less than 15 meters slant range.

An operating crew of not more than one man to conduct a single engagement.

A firing capability of one missile every 15 seconds from a single launcher.

Two power sources: one in the launcher for system warmup and firing, and one integral to the missile in flight.

System maintenance in a state of readiness for extended

~~CONFIDENTIAL~~

UNCLASSIFIED

periods, such that missile launch would be possible immediately upon receipt of an "on target" signal.

Warmup time from a cold start not to exceed 5 seconds required; 1 second desired.

Capability of efficient operation (1) under extreme cold and extreme hot weather conditions; (2) after exposure to rain or after extended periods of immersion in salt or fresh water; and (3) after being stored in outside storage without any protection from the elements for a period of 2 years.

Design and construction of the system, less missile, for maximum simplicity and ease of maintenance and production.

(U) In the case of competing characteristics, the developer was to give priority in this order: weight, simplicity, and effectiveness (to include accuracy, lethality, reliability, immunity to enemy countermeasures, range and altitude, and safety).

(U) Although the REDEYE feasibility study program had not been completed, it was considered that the current state of the art would support the development of a forward area, man-transportable, seeker-equipped guided missile capable of meeting the specified military characteristics. The REDEYE would be employed as an all-arms air defense weapon for protection of combat and support troops in the battle zone against attack by low-flying hostile aircraft, many of which would be beyond the engagement capability of other forward area air defense weapons because of ground environment. Therefore, it was not anticipated that the REDEYE would reduce the requirement for the MAULER, HAWK, or NIKE systems for air defense in the combat zone.⁸

Recommendation for Initiation of R&D Program

(U) In a letter to the Chief of Ordnance, on 10 November 1958,

⁸OTCM 37000, 19 Feb 59, subj: Man-Transportable ADGM Sys (REDEYE) - Recording of MC's. RSIC.

the Commanding General of AOMC recommended that a REDEYE development program be initiated and that the contractor's effort be redirected to best support such a program. At that time, the human factors tests, target radiation tests, and seven of the nine LTV firings had been completed, but the feasibility demonstration of the complete guidance and control system would not begin until March 1959. Nevertheless, it was considered that feasibility had been established in the two areas of particular concern. In order to meet the stated CONARC requirement for delivery of the REDEYE by FY 1961, it was imperative that authority and funds be furnished for initiation of development no later than January 1959.

(U) To implement the Phase II development program, a total of \$8,875,000 in FY 1959 RDTE* funds would be required, including \$3,875,000 for R&D and \$5,000,000 for PEMA/S.** In addition to these RDTE funds, \$3,900,000 in regular FY 1959 PEMA funds would be required for procurement of long leadtime items of tactical hardware. So far, AOMC had received program authority for only \$3,875,000 in R&D funds (\$1,000,000 from the Army and \$2,875,000 from the Marine Corps). The AOMC Commander warned that any delay in furnishing the necessary funds and authority to initiate Phase II development would result in an extended REDEYE operational availability date.⁹

(U) The conditional weapon system plan forwarded with AOMC's recommendation reflected the time phasing set forth in Convair's plan of November 1956; i.e., the commencement of tactical production within 18 months after the initiation of a complete system

* Research, Development, Test, and Evaluation.

** Procurement of Equipment and Missiles, Army, in Support of R&D.

⁹ Ltr, CG, AOMC, to CofOrd, 10 Nov 58, subj: Auth for REDEYE Dev, atchd as incl to SS ORDXR-RM-28, ARGMA Cdr to CG, AOMC, 3 Nov 58, subj: REDEYE Dev Program. Hist Div File.

development program. Assuming the initiation of a fully funded Phase II effort in January 1959, the industrial engineering effort would begin in July 1959, followed by the system demonstration in March 1960, industrial procurement in April 1960, and an initial operational capability in March 1961. (See Chart 5.) The projected R&D program cost of \$10,455,000 through completion of the Phase II effort in FY 1961 compared favorably with Convair's original R&D estimate of \$10,430,000; however, about \$13,500,000 in PEMA/S funds would be required for procurement of R&D test missiles and equipment, bringing the total RDTE projection to \$23,955,000. The projected PEMA cost for 40,500 REDEYE production units was \$70,300,000. This, together with \$232,000 in OMA* funds, increased the total program estimate to \$94,487,000 for the FY 1958-63 period. (See Table 1.)

(U) MG J. H. Hinrichs, the Chief of Ordnance, concurred in AOMC's conclusion that feasibility had been demonstrated in the two principal problem areas and that development of the REDEYE should begin, even though there was yet no demonstrated evidence that the SSKP stated in the MC's could be attained. He was not at all sure, however, that adequate funds would be available and was reluctant to proceed with the Phase II effort without firm assurance of full fiscal support. General Hinrichs asked for such assurance in a letter to the Chief of Research & Development on 31 December 1958. He wrote:

It is common knowledge that funding of air defense weapons is currently inadequate; moreover, that it is unrealistic to assume this condition will significantly improve either during this FY or in FY 60. To meet funding requirements of the REDEYE program in FY 59, we have only \$1,000,000 Army R&D and \$2,875,000 USMC funds. No other money has been made available. I believe that an action which continues any guided missile program without due regard to

* Operation and Maintenance, Army.

CHART 5

RED EYE MISSILE SYSTEM

PROVISIONAL COMMODITY PLAN - NOVEMBER 1958

	CY 58				CY 59				CY 60				CY 61				CY 62			
	1	2	3	4	1	2	3	4	1	2	3	4	1	2	3	4	1	2	3	4
COMPLETE SYSTEM	<div style="display: flex; justify-content: space-around; align-items: flex-start;"> <div style="text-align: center;"> <p>F P</p> <p>↓</p> <p>0.8</p> <p>FEASIBILITY STUDY</p> </div> <div style="text-align: center;"> <p>T</p> <p>↓</p> <p>10.4</p> <p>ENGINEERING DESIGN</p> </div> <div style="text-align: center;"> <p>SD</p> <p>↓</p> <p>20.4</p> </div> <div style="text-align: center;"> <p>O</p> <p>↓</p> <p>23.9</p> </div> </div>																			
	<div style="border: 2px solid black; padding: 5px; display: inline-block;">INDUSTRIAL PROCUREMENT</div>																			

- F FUNDS REQUIRED
- P PROGRAM AUTHORITY REQUIRED
- T TRAINING COMMENCES
- SD SYSTEMS DEMONSTRATION
- O ORDNANCE READINESS DATE

TABLE 1—REDEYE Program Estimate
(in millions of dollars)

FY	R&D			PEMA/S	RDTE TOTAL	PEMA	OMA	GRAND TOTAL	REDEYE PROCUREMENT
	ARMY	USMC	TOTAL						
1958	.230 ^a	1.350 ^a	1.580 ^a	--	1.580 ^a	--	---	1.580	--
1959	1.000 ^b	2.875 ^b	3.875 ^b	5.000	8.875	3,900	---	12.775	400
1960	2.000	2.000	4.000	6.000	10.000	16.400	.060	26.460	4,100
1961	.500	.500	1.000	2.500	3.500	19.200	.172	22.872	12,000
1962						16.200		16.200	12,000
1963						14.600		14.600	12,000
	3.730	6.725	10.455	13.500	23.955	70.300 ^c	.232	94.487	40,500 ^c

49

^a Actual cost of Feasibility Study Program.

^b Funds furnished as of November 1958.

^c The requirement for 40,500 missiles was based on unofficial USMC and Army expressions. Launch tube (shipping container) and grip stock were included in the cost of the missiles. The grip stock requirements were computed on the basis of 1 for 8 missiles.

SOURCE: DF, CofOrd to CRD, DA, 31 Dec 58, subj: AD GM Sys, REDEYE, & incl thereto.

the useful availability of the end product or to economical development is detrimental to the entire guided missile effort.

I strongly recommend that development of the REDEYE system not be initiated unless the funding requirement can be fully met. If funding cannot be assured then development should not be initiated until the fiscal support is commensurate with the urgency of the military requirement. Further, we would return the USMC funds (now in hand) to the Marine Corps. . . .

For program continuity, and to allow the USMC sufficient time in which to reprogram its money, if required, a firm position on this proposal . . . is required by 15 January 1959.¹⁰

Engineering Development Program Approved

(U) By a Determination & Findings (D&F) signed on 5 April 1959, the DA Staff approved the negotiation of a contract with Convair/Pomona^{*} for the Phase II development effort. It was clear, however, that General Hinrichs' advice was not heeded, as the FY 1959 RDTE funding program fell over \$2 million short of the \$8,875,000 requested. Aside from the \$3,853,000 in R&D funds already on hand (\$978,000^{**} Army; \$2,875,000 USMC), only \$2,525,000 in PEMA/S funds was furnished, for a total of \$6,378,000.

(U) On 30 June 1959, the REDEYE contract (ORD-1202) with GD/P was supplemented for \$5,348,500, enough to carry the program through 30 April 1960. At the same time, General Dynamics received a facilities contract (DA-04-495-ORD-1742) for \$217,500 to provide laboratory, instrumentation, and development equipment. The remaining \$812,000 was distributed among the various governmental agencies

* The Convair/Pomona Division of General Dynamics later became known as the Pomona Division and is hereafter referred to as General Dynamics/Pomona (GD/P).

** The \$1 million in Army R&D funds shown as on hand in Table 1 and elsewhere was actually \$978,000 rounded off to the nearest million.

¹⁰ DF, CofOrd to CRD, DA, 31 Dec 58, subj: ADGM Sys, REDEYE. Hist Div File.

participating in the program, the largest share going to Picatinny Arsenal for development of the warhead and fuzing system.¹¹

The Updated Commodity Plan

(U) The delay in initiation of the Phase II development program and the lack of PEMA money for commencement of the industrial effort in FY 1960 led to drastic changes in the REDEYE commodity plan. The initiation of industrial engineering effort was moved back from July 1959 to October 1960, the system demonstration from March 1960 to May 1961, the commencement of production prototype deliveries from April 1960 to October 1961, and the Ordnance Readiness Date from March 1961 to November 1962. (See Chart 6.)

(U) Under the revised plan, the engineering development program would still be completed by December 1961 with FY 1961 RDTE funds, but at a lower estimated cost than that originally projected. The \$7,958,000 already provided for FY 1958-59, plus program guidance of \$8,435,000 for FY 1960 and \$4,625,000 for FY 1961, indicated a total RDTE* cost of \$21,018,000—\$2,937,000 less than the original projection. Included in the revised estimate were funds for 660 R&D test missiles and equipment. Aside from the 30 missiles purchased with FY 1958 funds for the feasibility demonstration program, 280 were programmed for procurement in FY 1959, 150 in FY 1960, and 200 in FY 1961, with deliveries to be completed by 30 June 1961.

* Beginning in FY 1960, R&D and PEMA/S funds were consolidated under the RDTE appropriation.

¹¹ (1) ARGMA Diary, 1 Apr 59 - 30 Jun 59, p. 51. Hist Div File. (2) REDEYE Msl Sys Plan, ARGMA MSP 8, 15 Feb 60, p. D-12. RHA Bx 14-209. (3) ADSIMO Rept, REDEYE Wpn Sys R&D Funding, FY 1958-70, Feb 73. Hist Div File.

CHART 6

RED EYE

ARGMA RES TRC-5
COMMODITY PLAN (U)

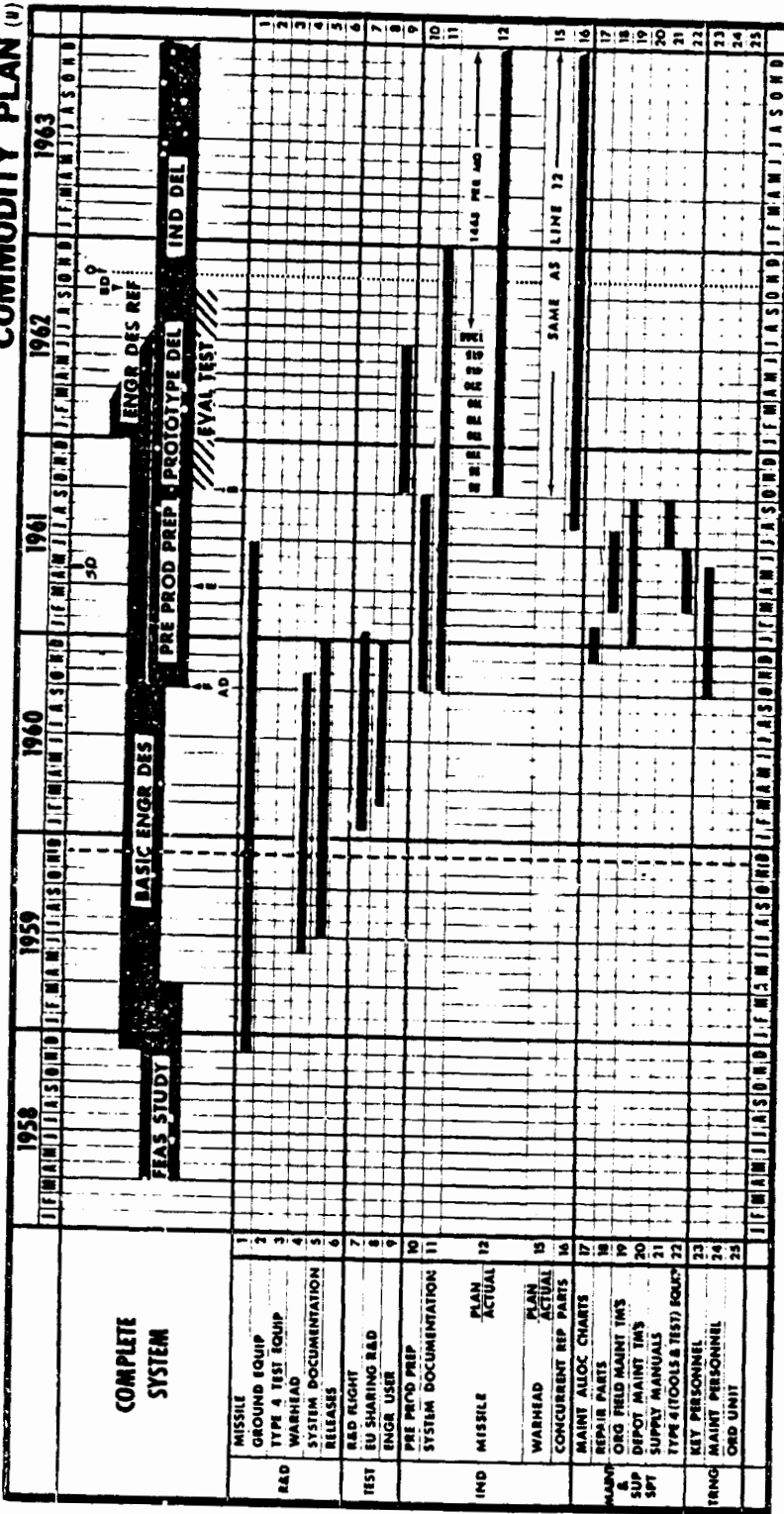

- AD FUNDED DELIVERY
- B BUDGET PROP SUBM FOR FUNDS TO
- BD BUDGET PROP SUBM FOR DEL TO
- D DEPLOYMENT
- E IND ECO CONTROL
- F FUNDS REQUIRED
- IT BEGIN INSTRUCTOR TRAINING
- O ORD READINESS DATE
- P PROGRAM AUTH REQ
- SD SYSTEM DEMONSTRATION
- T BEGIN ORD UNIT TRAINING
- K1 ENGR CONCEPT INSP
- K2 DESIGN CHARACT INSP
- K3 DESIGN RELEASE INSP
- K4 PRE PROD EQUIP INSP
- K5 SPEC COORD INSP

ARMY REPLY & ORDER NUMBER (SECRET)

NO RE 702

REP B

DATE 30 NOV 59

UNCLASSIFIED

~~CONFIDENTIAL~~

~~(S)~~ The REDEYE industrial plan was also revised to reflect lower production quantities and costs than originally projected. Instead of 40,500 units at a cost of \$70,300,000, a total of 37,590 units would be procured during the FY 1961-64 period at an estimated cost of \$63,880,000, with the Marine Corps contributing \$15,965,000 of that amount. Of the programmed production units, 26,900 would be allocated to the Army and the remaining 10,690 to the Marine Corps and other customers. Industrial deliveries were scheduled to begin in FY 1962 (October 1961) and be completed in FY 1965.¹²

¹²(1) ARGMA Hist Sum, 1 Jan 59 - 31 Dec 59, p. 133. (2) ARGMA Diary, 1 Jul - 31 Dec 59, p. 233. (3) REDEYE Msl Sys Plan, ARGMA MSP 8, 15 Feb 60, pp. D-16 & E-9. RHA Bx 14-209.

~~CONFIDENTIAL~~

UNCLASSIFIED

CHAPTER IV

2) BASIC ENGINEERING DESIGN (U)

(U) General Dynamics began full-scale development of the REDEYE in July 1959, and, in March 1960, won a contract for development of the self-propelled MAULER weapon system. As stated earlier, these two weapons represented the proposed solution to the forward area, low-altitude air defense problem, and they were desperately needed to replace the outmoded .50-caliber machine gun which could not cope with the prevailing air threat to land combat troops. Although the GD/P facility had been declared as adequate for the efficient execution of both the REDEYE and MAULER programs, the contractor's performance was later the subject of sharp criticism as both projects suffered from unsolved technical problems, compromises in the MC's, schedule slippages, and cost increases. Contributing to these untoward developments, however, was the Army's failure to provide adequate fiscal support for efficient, conventionally phased programs. The funding support accorded the MAULER and REDEYE projects was neither commensurate with the urgency of the military requirement nor with the magnitude of the tasks, which were grossly underestimated by both the Army and the contractor. The MAULER succumbed to its adversities in July 1965,¹ just as engineering development of the REDEYE neared completion—some 4 years late.

(U) In early 1959, the development of a man-portable, seeker-equipped guided missile capable of meeting the specified MC's was considered to be feasible and within the realm of existing

¹See Mary T. Cagle, *History of the MAULER Weapon System* (MICOM, 19 Dec 68).

technology. By December 1960, however, it had become obvious that the REDEYE was a very intricate missile system requiring an application of technology which clearly pushed the state of the art. As a result of major technical problems and the lack of adequate fiscal support for efficient and economical execution of the project, the time required for completion of the engineering development effort increased from 30 months (July 1959 - December 1961) to more than 6 years (July 1959 - November 1965), and minor development work on the missile system continued through FY 1967. Award of the initial industrial contract was delayed from FY 1961 (October 1960) to April 1964, and the initial operational capability (Ordnance Readiness Date) was moved back from November 1962 to October 1967, when the first tactical REDEYE unit was trained, equipped, and ready for deployment. The total RDTE cost of the REDEYE weapon system increased from the original estimate of \$23,955,000 for the FY 1958-61 period, to \$76,767,000 for the FY 1958-67 period, the Marine Corps contributing \$10,500,000 of the latter amount. Development costs for 1968, 1969, and 1970 totaled \$5,309,000, increasing the RDTE funding to \$82,076,000 for the 13-year period.²

Contractor Structure

(U) General Dynamics, as the prime contractor, had full responsibility for the overall system design and for the production and delivery of a complete REDEYE weapon system capable of meeting the specified MC's. The selection of GD/P for production of the REDEYE entailed a mobilization risk, inasmuch as the Pomona facility was a Naval Industrial Reserve Ordnance Plant (NIROP) engaged in production of the TARTAR and TERRIER weapon systems.

² ADSIMO Rept, REDEYE Wpn Sys R&D Funding, Feb 73. Hist Div File.

The Bureau of Ordnance, Department of the Navy, in May 1959, granted permission to the Chief of Ordnance for development and production of the REDEYE missile system at the Pomona plant on a non-interference basis, and for use of the Naval Ordnance Test Station at China Lake, California, for contractor development tests of the REDEYE.

(U) General Dynamics, with approval of ARGMA and the Marine Corps, selected the Atlantic Research Corporation (ARC) for development of the two-stage rocket motor and the Philco Corporation as subcontractor for the infrared seeker. After a careful search for a high-impulse solid propellant offering adequate safety for shoulder-firing, it was determined that ARC's propellant was the most likely to meet performance requirements in the time allowed for REDEYE development. The selection of Philco for development of the seeker was based on its experience in producing the SIDEWINDER 1C seeker, a modification of which was to be used in the REDEYE.

(U) Picatinny Arsenal had responsibility for development of the warhead and fuze. The Magnavox Corporation developed the fuze under a subcontract to Picatinny. In addition to the warhead effort, Picatinny Arsenal also developed an alternate double-base propellant grain for use in the event that ARC's propellant could not be safely shoulder-fired. Among other agencies participating in the program were the Signal Corps (development of batteries and conduct of vulnerability studies); Aberdeen Proving Ground (human engineering studies); White Sands Missile Range (engineering and evaluation testing); and ARGMA (monitoring of infrared guidance and propulsion development).³

³(1) REDEYE Msl Sys Plan, ARGMA MSP 8, 15 Feb 60, pp. A-2, C-3. RHA Bx 14-209. (2) DF, Chf, REDEYE Sec, AD Br, RDD, to Chf, Con Ofc, ARGMA, 8 Feb 60, subj: Cdr, ARGMA, DF, Dtd 3 Apr 59, Concerning Prog Repts. Hist Div File.

Development Concept and Target Dates

(U) The revised commodity plan (*see* Chart 6) was designed to permit the initiation of industrial effort before completion of the development program and flight test of the tactical design. With the extensive design work done by the contractor in preparation of the REDEYE proposal and the data obtained during the feasibility demonstration, it was anticipated that the basic weapon system design and the fabrication of test hardware could be completed within 8 months (July 1959 - February 1960). The contractor development test program at NOTS would be conducted during the next 10 months (March - December 1960), followed by shoulder-firings of tactical prototypes for the system demonstration in May 1961 and completion of the engineering development program in December 1961 with FY 1961 RDTE funds. The key target dates for the telescoped program in FY 1960-61 were as follows:

- Dec 59 -- Design Characteristics Review
- Mar 60 -- Begin Unguided (LTV) Flight Tests
- May 60 -- Begin Program-Guided (LTV-1B) Flight Tests
- Jun 60 -- Begin Seeker-Guided (GTV) Flight Tests
- Jul 60 -- Preliminary Release to Industrial
- Aug 60 -- Design Release Inspection
- Oct 60 -- Interim Release to Industrial
- Dec 60 -- Completion of Contractor Development Test Program
and R&D Documentation, and Final Release to
Industrial for Initial (FY 61) Procurement
- May 61 -- System Demonstration

Admittedly, some risks were involved in the release to production before flight testing the tactical design. However, it was expected that the initial pilot line production would not be of the design existing at the time of release, but would be of the design that was firm 4 months before the required delivery date for the first pilot production round. The early release was necessary in order for the Industrial Division to meet the

revised readiness date of November 1962.⁴

(U) The primary objectives of the REDEYE development test program were to obtain developmental data; to determine the configuration of aerodynamic surfaces; to validate in-flight operability of an experimental model; and to demonstrate the safety, performance, and reliability of the engineering model (GTV-2). The latter would be composed of engineering models of each item of equipment necessary to demonstrate all technical principles of system operation. These models would be developed following the verification of basic system concepts in the experimental (LTV) firings.

(U) The R&D test plans called for 260 firings of the various REDEYE configurations at NOTS, during the period March 1960 through December 1960. These were divided in three phases. The first phase would consist of 50 LTV-1 unguided firings over a 7-month period, beginning in March 1960, to acquire data on the booster and sustainer motor operation, and to evaluate aerodynamic stability and roll rates. In the second phase, 50 LTV-1B experimental model rounds would be fired, during the May-September 1960 period, to determine missile aerodynamic characteristics, including stability, control, roll rates, velocity, and drag in controlled flight under conditions of programmed maneuvers. In the third phase, 160 engineering models (GTV-2's) would be test fired, during the June-December 1960 period, to evaluate operation of the tactical weapon and launcher system; to explore missile performance against various 600-knot targets with and without flares; to check operation of the system on outbound, inbound, and crossing courses; to evaluate performance of the fuze and S&A device; and to check

⁴(1) REDEYE Dev Test Plan, ARGMA TP-9, 1 Feb 60, pp. 24-27.
(2) ARGMA MSP 8, *op. cit.*, pp. A-1, A-2, A-5, C-2, D-5, D-10, D-15. Both in RHA, Bx 14-209.

warhead effectiveness. The experimental LTV rounds would be fired from the "G" range, using both the GD/P modified M-45 gun mount with tailored armor added and the NOTS pilot round launcher, depending upon pre-spin requirements. The GTV-2 rounds would be fired from the NOTS G1 range, using the GD/P launcher mount and missile control system. Assuming the successful completion of the 260-round R&D flight test program, 40 tactical prototypes would be shoulder-fired for the system demonstration in 1961, along with 30 GTV-3 rounds to test the alternate guidance package.⁵

(U) As stated earlier, the RDTE funding requirements for FY 1960-61 totaled \$13,060,000—\$8,435,000 for FY 1960 and \$4,625,000 for FY 1961.⁶ The funds actually received and obligated came to \$12,741,000—\$9,393,000 in FY 1960 and \$3,348,000 in FY 1961. This increased the total development cost to \$20,699,000 for the FY 1958-61 period, including a Marine Corps contribution of \$7,550,000.⁷ As of December 1960, AOMC still expected that development would be completed by December 1961 with 1961 funds.⁸

Component Development - Experimental Model

(U) During the first 6 months of Phase II development, General Dynamics directed its efforts toward system analysis and design; fabrication, procurement, and checkout of experimental model hardware; and ground and flight tests. The component design specifications were based on data obtained from the continuing

⁵ (1) REDEYE Dev Test Plan, ARGMA TP-9, 1 Feb 60, pp. 24-25. (2) ARGMA TP-9, 15 May 60, pp. 25-28. (3) REDEYE Prog Rept, Nov 59, pp. 4-5, 8. All in RHA Bx 14-209.

⁶ See above, p. 51.

⁷ ADSIMO Rept, REDEYE Wpn Sys R&D Funding, Feb 73.

⁸ DF, Chf, AOMC Con Ofc, to Distr, 6 Dec 60, subj: Mins of REDEYE Wpn Sys Mgr's Rept, p. 3. Hist Div File.

UNCLASSIFIED

~~**CONFIDENTIAL**~~

laboratory studies and the extended phase of the feasibility flight test program which ended with six GTV firings (Rounds 10 through 15)* during the period 31 October to 20 November 1959. The Design Characteristics Inspection was held at the contractor's plant on 20-21 October 1959. It was followed, on 9-10 December, by the Design Characteristics Review (DCR) at ARGMA, which was attended by 150 representatives of interested agencies.⁹

(U) The weapon system design presented at the DCR indicated some minor changes in the physical characteristics of the proposed REDEYE, but not in the basic system concept. The size of the missile remained unchanged; i.e., 2.75 inches in diameter and 43 inches long. The estimated weight of the missile and launcher/gripstock, however, was increased from 18.2 to 19.6 pounds (the missile from 14.5 to 15.6 lbs. and the launcher/gripstock from 3.7 to 4.0 lbs.). These preliminary estimates were considered to be the best compromise between portability and flight performance. The size and weight of the final weapon system, of course, would depend upon the type of materials selected, the severity of field handling environments, and the results of wind tunnel and development flight tests.¹⁰

Seeker Head

(U) The seeker section consisted of the IR dome, seeker amplifier, optics, and IR cell. The missile used a proven SIDEWINDER seeker operating in the 2.2 - 2.7 micron region of the spectrum. The seeker detected IR radiation emitted by a target and converted this energy into two separate signals. One of these

* See fn 7, p. 43.

⁹ (1) ARGMA Hist Sum, 1 Jan - 31 Dec 59, p. 130. (2) REDEYE Prog Repts, Nov 59, pp. 3-4; Dec 59, p. 1. RHA Bx 14-209.

¹⁰ REDEYE Msl Sys Plan, ARGMA MSP 8, 15 Feb 60, p. D-1. RHA Bx 14-209.

~~**CONFIDENTIAL**~~

UNCLASSIFIED

ARGM

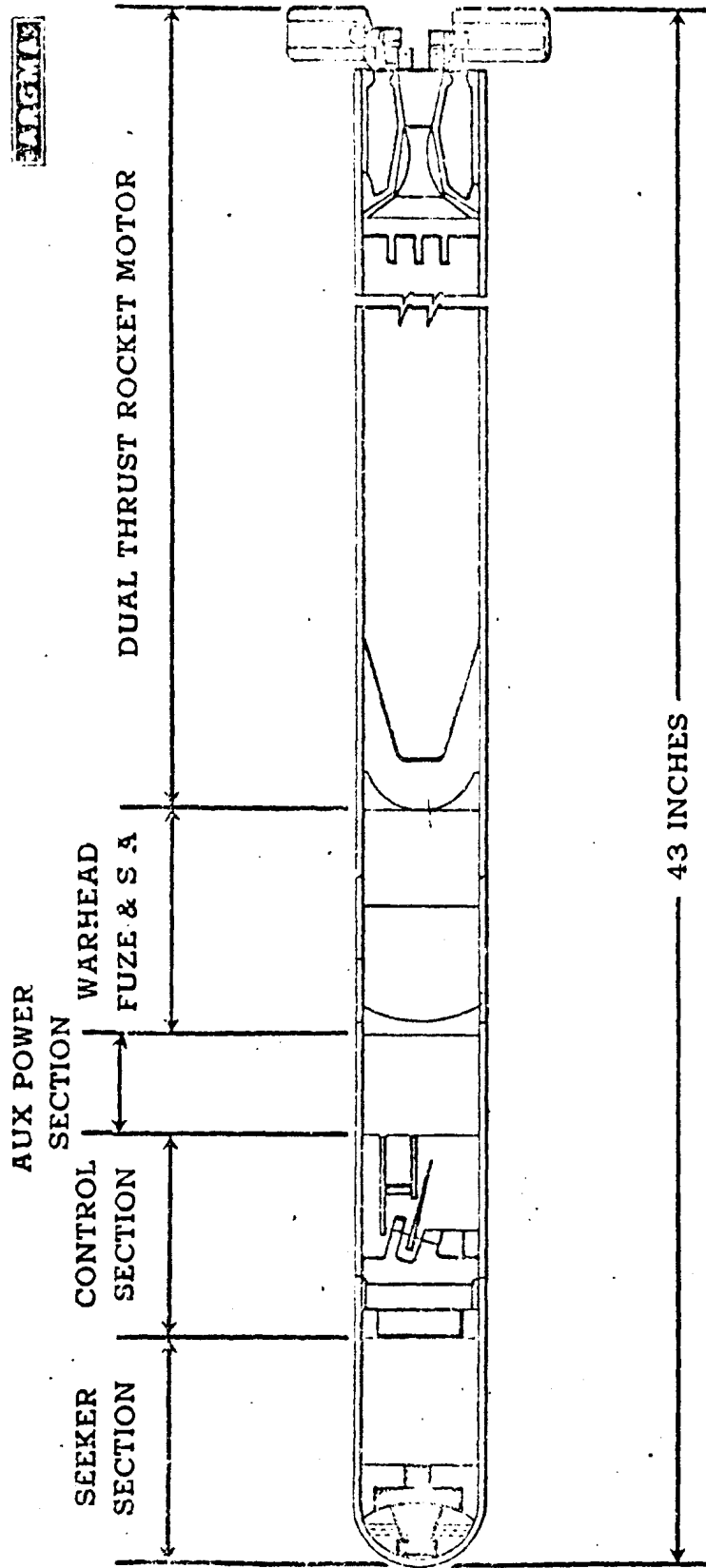

WT - 15.6 POUNDS

RED EYE MISSILE SECTIONALIZATION

ARMY ROCKET & GUIDED MISSILE AGENCY	
WASHINGTON, D. C. 20330	
FORM 753	REV
PA	DATE 31 DEC 59

UNCLASSIFIED

~~CONFIDENTIAL~~

signals was used to process the gyro and optics of the seeker so that the target was continually tracked. The other signal was fed to the autopilot (in the control section), which converted it into information to guide the missile to the target.¹¹

(S) General Dynamics completed specifications for the seeker head in November 1959, and awarded the Philco Corporation a development subcontract in December.¹² Since the IR seeker used during the feasibility study program was found to be compatible with the REDEYE mission, development effort in the seeker area consisted primarily of optimizing the existing design.¹³ Among the design improvements made in the seeker gyro were an increased aperture to provide greater sensitivity; a new center post design for supporting the secondary mirror to improve background discrimination; a new gyro gimbal of increased rigidity; an improved lead sulfide cell, doubling its sensitivity; and an improved reticle with a reduced field of view.¹⁴ Target acquisition studies showed that the field of view could be decreased to $\pm 1^\circ$ with small loss in tracking performance. Since a small field of view was also desirable to reduce IR background interference, the field was reduced to $\pm 1.25^\circ$. Performance boundary studies showed that a seeker look angle allowance of 40° was more than adequate, but this could be increased if it became a limiting factor in performance.¹⁵

(U) While optimizing the original seeker design for the basic

¹¹ REDEYE Dev Test Plan, ARGMA TP-9, 1 Feb 60, p. 43. RHA Bx 14-209.

¹² (1) REDEYE Prog Rept, Nov 59, p. 5. RHA Bx 14-209. (2) REDEYE Chronology. Hist Div File.

¹³ REDEYE Msl Sys Plan, ARGMA MSP 8, 15 Feb 60, p. D-6. RHA Bx 14-209.

¹⁴ REDEYE Prog Rept, Nov 59, p. 5. File same.

¹⁵ ARGMA MSP 8, *op. cit.*, p. D-1.

~~CONFIDENTIAL~~

UNCLASSIFIED

system, Philco began research work on an alternate two-color seeker to permit use of the REDEYE against targets which did not emit enough IR energy for homing with the existing system.¹⁶

(Development of this alternate seeker was planned as part of the product improvement program, but the need for it later became critical when development tests revealed that the target detection capability of the basic seeker fell short of meeting the MC's.)

Control Section

(U) Located adjacent to the seeker head, the control section consisted of the autopilot, solenoid, and control assembly. Its function began with receipt of the guidance signal from the seeker amplifier. The autopilot filtered and shaped the signal, established the navigation constant, and amplified the signal. Drivers applied this shaped signal to the coil of the solenoid, which acted through a crosshead and sector gate assembly to drive the canards (control surfaces) in and out to achieve guidance.

(U) Missile steering was accomplished by rolling the missile in flight (the roll rate was initially set at 7-15 revolutions per second) and extending and retracting the fixed incidence control surfaces as required during a portion of each revolution. Missile roll was initiated by canted nozzles in the booster motor and maintained by canted tail fins. Considerable knowledge was gained on the rolling missile form of guidance during the feasibility demonstration program. However, because of the greater velocities required of the tactical missile, much more development was needed on the control surfaces and stabilizing tail fins.¹⁷ As will be noted later, missile roll rate control presented one of the most difficult problems of any encountered in the R&D program.

¹⁶ REDEYE Dev Test Plan, ARGMA TP-9, 1 Feb 60, p. 44. RHA Bx 14-209.

¹⁷ (1) *Ibid.*, pp. 44-45. (2) ARGMA MSP 8, *op. cit.*, p. D-6.

UNCLASSIFIED

~~CONFIDENTIAL~~

Electrical Power Section

(U) The missile power supply was furnished by a thermal battery similar to the one used in the feasibility demonstration program. Developed by the Eureka-Williams Company for a Diamond Ordnance Fuze Laboratories project, this battery needed no attention until the instant of activation, which was accomplished remotely with a single ignition pulse to an internal squib. Experience gained during the feasibility firings indicated that this type of battery was the best available choice for use in the REDEYE development phase. However, it had to be repackaged for the engineering model and some development was required to meet performance requirements of the tactical missile. In January 1960, General Dynamics let subcontracts for developmental batteries to the Eureka-Williams Company and Eagle-Picher Company.¹⁸ Tactical batteries were to be furnished by the Signal Corps.

Warhead Section

(U) Development of the warhead and fuze was the responsibility of Picatinny Arsenal. The Magnavox Corporation developed the fuze under a subcontract. Located at the rear of the electrical power section and in front of the rocket motor, the complete warhead section was cylindrical in shape, 2.75 inches in diameter, and 4.68 inches long, and had a gross weight of about 2.35 pounds. The tubular cases for the original XM-45 warhead and XM-804 fuze were bonded together with an epoxy adhesive to form the warhead section and a portion of the outer skin of the missile.¹⁹

(S) In the course of the development program, Picatinny

¹⁸(1) *Ibid.*, p. D-6. (2) Convair Rept, 30 Jun 59, subj: REDEYE Feasibility Program Final Rept, p. 104. RSIC. (3) REDEYE Dev Test Plan, ARGMA TP-9, 1 Feb 60, p. 45. RHA Bx 14-209. (4) REDEYE Prog Rept, Jan 60, p. 2. File same.

¹⁹TIR 2-3-6A1, OCO, Jan 62, subj: Dev of GM Whd Sec for REDEYE, pp. 1-3. RSIC.

~~CONFIDENTIAL~~

UNCLASSIFIED

~~UNCLASSIFIED~~

~~CONFIDENTIAL~~

Arsenal built and tested warhead casings of steel, plastic, and titanium alloy. The latter material was selected for the XM-45 warhead, which was 3.24 inches long and weighed about 1.60 pounds. The titanium alloy case contained about 0.8 pound of HTA-3 explosive—a compound of 49 percent cyclotetramethylenetetranitramine (HMX), 29 percent trinitrotoluene (TNT), and 22 percent powdered aluminum. The small size and weight of the warhead dictated that target penetration be achieved before detonation for maximum effectiveness. It was designed to perforate at least 0.375 inch of aluminum at an angle of 80°. A nylon tube extending through the explosive charge of the warhead acted as a conduit for electrical wires running from the missile's power supply to the fuze and rocket motor.

(U) The original XM-804 fuze was 1.907 inches long and weighed about 0.75 pound. It was designed to insure that the missile was safe to handle and use under all conditions from assembly to firing. To protect launch area personnel, it had a built-in delayed arming of 90 to 150 feet from point of launch, and an acceleration sensitive switch to prevent motor ignition upon failure of booster (ejector) activation. Accelerative forces created by the missile in flight caused the fuze to perform its basic functions of igniting the rocket motor and arming the warhead. When acceleration of the missile was subnormal the fuze performed its safety (self-destruct) functions. When the fuze was armed, an initiating signal was generated upon contact with the target by one of two means. The primary method was an electromagnetic device called a Penetration Impulse Generator (PIG) for use against metallic targets. The secondary method was an inertial impact switch for use against non-metallic targets and as a backup to the PIG.²⁰

²⁰ (1) *Ibid.*, pp. 3, 6-7. (2) REDEYE Dev Test Plan, ARGMA TP-9, 15 May 60, p. 72. RHA Bx 14-209. (3) REDEYE Prog Repts, Mar - Sep 60. File same.

~~CONFIDENTIAL~~

~~UNCLASSIFIED~~

~~UNCLASSIFIED~~

~~CONFIDENTIAL~~

Propulsion System

(S) Personnel safety considerations during the launching phase dictated an unusual thrust program for the REDEYE missile. The design specifications called for a high level boost thrust (about 700 lbs.) for a nominal period of 60 milliseconds, which would accelerate the missile to the required muzzle velocity of about 100 fps and induce the necessary spin to the missile by means of canted tail fins. Booster burnout would be completed while the missile was still in the launch tube. The sustainer motor, delivering about 250 pounds of thrust for 5.6 seconds, would not be ignited until about 0.25 second after the missile emerged from the launch tube and traveled 25 feet. This delay would safeguard the man firing the missile. He would not be subjected to the hot, high velocity rocket jet, and therefore would not have to employ elaborate protective clothing or devices.

(U) The design characteristics for the REDEYE propulsion system were first defined in preliminary studies conducted by GD/P in 1956, and later refined in detailed investigations concluded in 1958 as part of the feasibility study program. General Dynamics, with the concurrence of the Army and Marine Corps, selected the Atlantic Research Corporation for the development subcontract in August 1959. The Phase II motor development effort began on 1 September 1959. The initial scope of work under ARC's subcontract called for the delivery of 175 units over an 11-month period. Major tasks included the design and evaluation of reinforced plastic and steel cases, booster and sustainer charge development, ignition system development, and experimental verification of the design. In addition to the development of alternate motor case designs by ARC, Picatinny Arsenal designed and developed an alternate double-base booster propellant grain as a backup in case the ARC propellant proved to be unsafe for shoulder firing. Upon completion of static tests, the Picatinny

~~CONFIDENTIAL~~

UNCLASSIFIED

design was shelved.

(U) For the booster, ARC selected a solid composite propellant of polyvinyl-chloride, ammonium-perchlorate (Arcite 386M). For the sustainer motor, it chose a single, end-burning grain of polyvinyl-chloride, ammonium-perchlorate, composite solid propellant (Arcite 427B) in which longitudinal silver wires were imbedded to increase the rate of burning. The accompanying illustration shows the propulsion system components, mean performance characteristics, and estimated weights of the plastic and metal case designs. The tail assembly initially proposed for the missile is shown in the drawing on page 61; however, many different configurations were later built and tested before the proper roll rate was achieved.

(U) Experiments with the plastic motor case, early in 1960, were disappointing. In January, a static firing of a sustainer motor in a plastic case resulted in a bond failure at ignition between the dead plate and the case. This problem was solved; however, in subsequent static firings, case porosity caused more failures, and emphasis was shifted to the steel motor case. In the interest of possible weight and cost reduction in the production item, work on the alternate plastic design was continued for a while, but was eventually dropped as impractical.

(U) The Atlantic Research Corporation completed the booster motor deliveries for the initial LTV-1 (ejector only) flight tests in March 1960, but ran into fabrication difficulties with the metal sustainer motor, causing a 6-week delay in delivery of metal parts. Its subcontractors were unable to deliver a case that would withstand the sustainer temperatures (1000°F) and pressures (2700 pounds per square inch). Problems then developed with the motor insulation, requiring an increase in the thickness to .080 inch. ARC successfully static fired the first engineering model of the complete propulsion system (sustainer and booster)

RED EYE ROCKET MOTOR

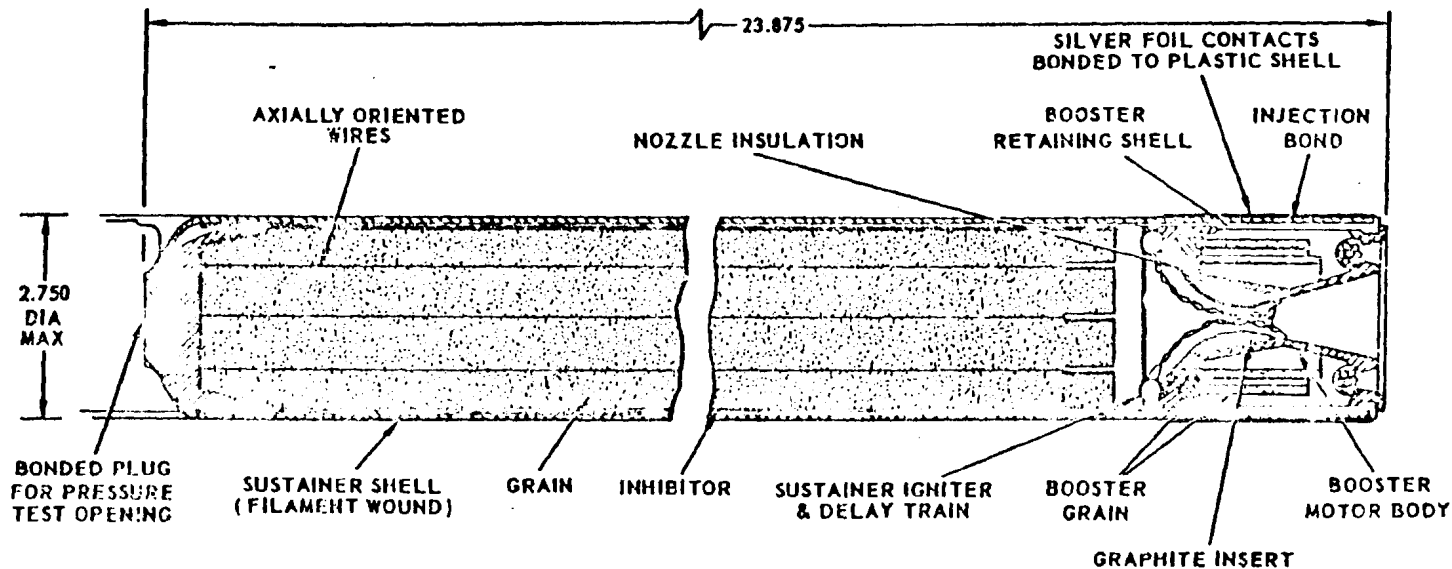

68

PERFORMANCE CHARACTERISTICS AT 70°F

	SUSTAINER	BOOSTER
THRUST (POUNDS)	256.5	739
BURNING TIME (SECONDS)	5.6	0.060
BURNING RATE (IN/SEC)	3.31	1.2
CHAMBER PRESSURE (PSI)	1980	2780
SPECIFIC IMPULSE (LB-SEC/LB)	252	222
TOTAL IMPULSE (LB-SEC)	1570	46.5
THRUST COEFFICIENT	1.65	1.48

ESTIMATED WEIGHTS

	PLASTIC DESIGN	METAL DESIGN
SUSTAINER SHELL	0.875	1.420
BOOSTER RETAINING SHELL	0.216	0.216
BOOSTER MOTOR BODY	0.983	0.983
BOOSTER GRAIN RETAINER	0.032	0.032
NOZZLE INSULATION	0.069	0.069
MISC	0.012	0.012
INSULATION (METAL DESIGN ONLY)		0.370
TOTAL INERT WT	2.058	2.972
SUSTAINER CHARGE	6.210	6.210
BOOSTER CHARGE	0.210	0.210
INHIBITOR & CHARGE CAP	0.420	0.420
IGNITER	0.100	0.100
TOTAL ROCKET WT	9.148	10.952

UNCLASSIFIED

~~CONFIDENTIAL~~

~~CONFIDENTIAL~~

UNCLASSIFIED

in May 1960. Flight tests of LTV's with the complete propulsion unit, using the modified M-45 gun mount, began in June 1960. To meet requirements of the NOTS Ammunition Safety Committee for shoulder launching a REDEYE missile, a minimum of 459 rounds had to be fired without a serious malfunction. This included both static and flight tests.²¹

Launcher/Gripstock Assembly

(U) The original launcher/gripstock combination was of the detachable design; i.e., the gripstock could be detached from the launch tube and reused. The launch tube, in which the missile was stored and shipped, had removable end caps with water-free glass seals. The primary purpose of the erect image sighting telescope mounted on the launch tube was to enhance the operator's ability to acquire and track targets and to estimate their range easily and accurately. Because the REDEYE would be used under all light conditions, a lens system with high light gathering characteristics was chosen. The fact that dawn and dusk are favorite times for aircraft strikes made this reasoning even more valid. The gripstock contained the electronics and battery pack. Its function was to spin up the gyro, tell the operator when the missile had acquired the target, and provide for igniting the internal battery and rocket motor squibs. The launch tube was designed with sufficient strength to contain an accidental booster detonation, or at least to deflect the blast away from the operator. Accidental discharge of the booster was minimized by an interlocking grip safety and a safety pin which had to be removed before system warmup. In addition, an infrared signal

²¹ (1) REDEYE Dev Test Plan, ARGMA TP-9, 1 Feb 60, pp. 21, 49. RHA Bx 14-209. (2) AMC TIR CD-1, Suppl III, Oct 63. RSIC. (3) ARGMA Diary, 1 Jan - 30 Jun 60, pp. 83-84. Hist Div File. (4) REDEYE Prog Repts, Jan - Jun 60. RHA Bx 14-209.

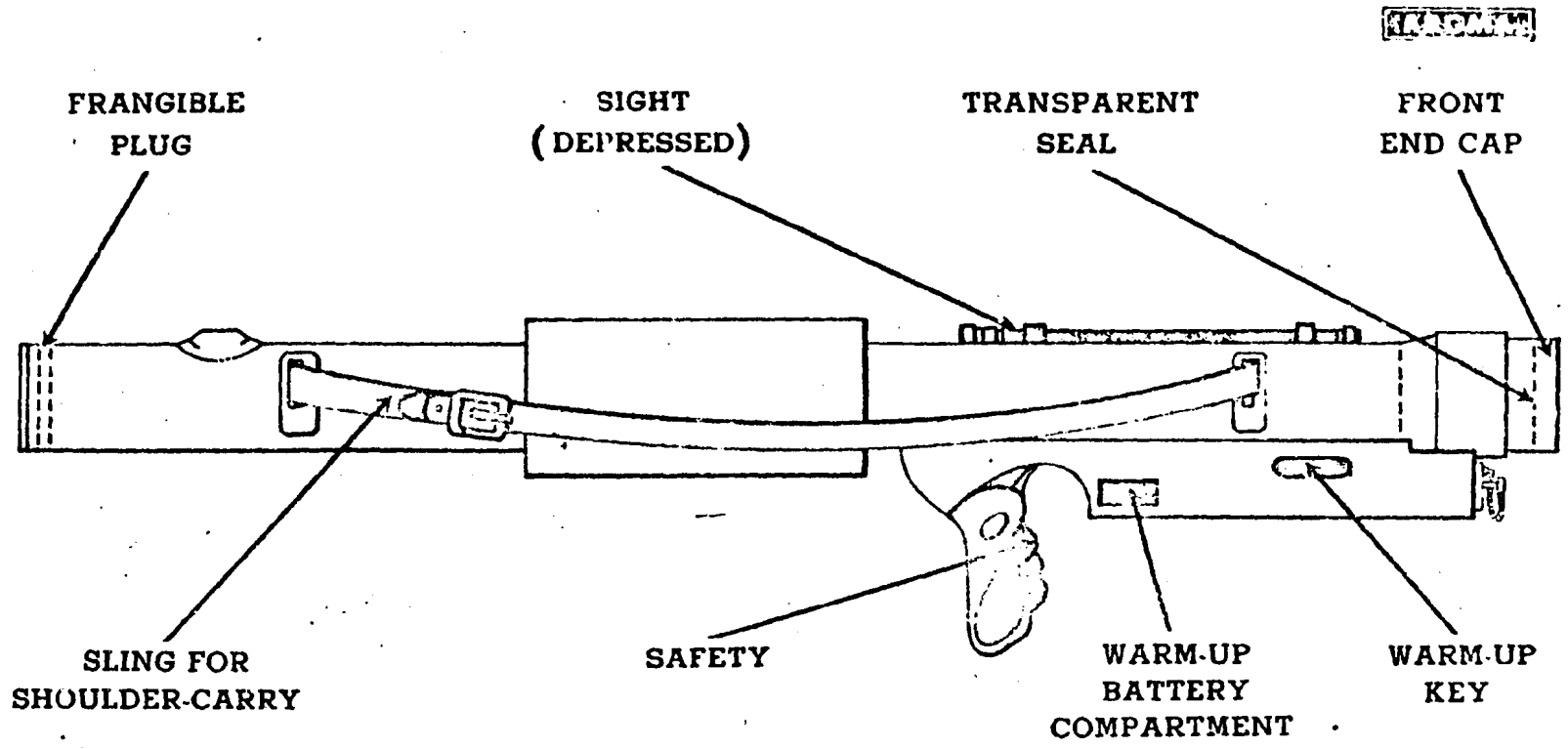

Weight: 4.0 lbs.

**RED EYE LAUNCHER
EXTERNAL CONFIGURATION**

ARMY ROCKET & GUIDED MISSILE AGENCY	
RD RE-752	REV
P.C.	DATE 31 DEC 59

had to be present to allow completion of the firing circuit.²²

(U) In the interest of increased reliability and operability, AOMC, with the concurrence of the Marine Corps and CONARC, decided to replace the detachable launcher/gripstock combination with the unitized system. Use of the detachable (separable) assembly would reduce system reliability below the minimum stated in the MC's and place severe technical restrictions on growth potential. While operation of the system would be equivalent with either the separable or unitized design, the time between shots would be about halved with the latter system (19 seconds versus 10.5 seconds). The estimated unit cost of the unitized launcher was \$300, in contrast to \$331 for the separable system (\$250 for the gripstock and scope; \$81 for the launch tube). Each unitized launcher could be reloaded with a complete REDEYE from 6 to 10 times at depot and/or factory level; whereas, a minimum of 1 gripstock per 8 missiles would be required for the separable system. The external configuration was the same for both systems.²³

(U) Early in 1960, General Dynamics completed delivery of REDEYE simulators for use in operations research tests similar to those conducted during the feasibility study program. Weighted and balanced to resemble the tactical REDEYE, the simulator detected target infrared radiation and recorded the operator's reaction on film. Marine Corps personnel performed extensive operations tests in landing exercises at Camp Pendleton, California, and Camp Lejeune, North Carolina. Additional tests

²² (1) REDEYE Dev Test Plan, ARGMA TP-9, 15 May 60, pp. 15, 73. (2) REDEYE Msl Sys Plan, ARGMA MSP 8, 15 Feb 60, p. D-5. RHA Bx 14-209.

²³ (1) Mins of REDEYE Steering Com Mtg, 11 May 60. (2) TT, CG, AOMC, to CofOrd, *et al.*, 20 May 60. (3) AOMC Hist Sum, 1 Jan - 30 Jun 60, p. 40. All in Hist Div File.

REDEYE TACTICAL SIMULATOR

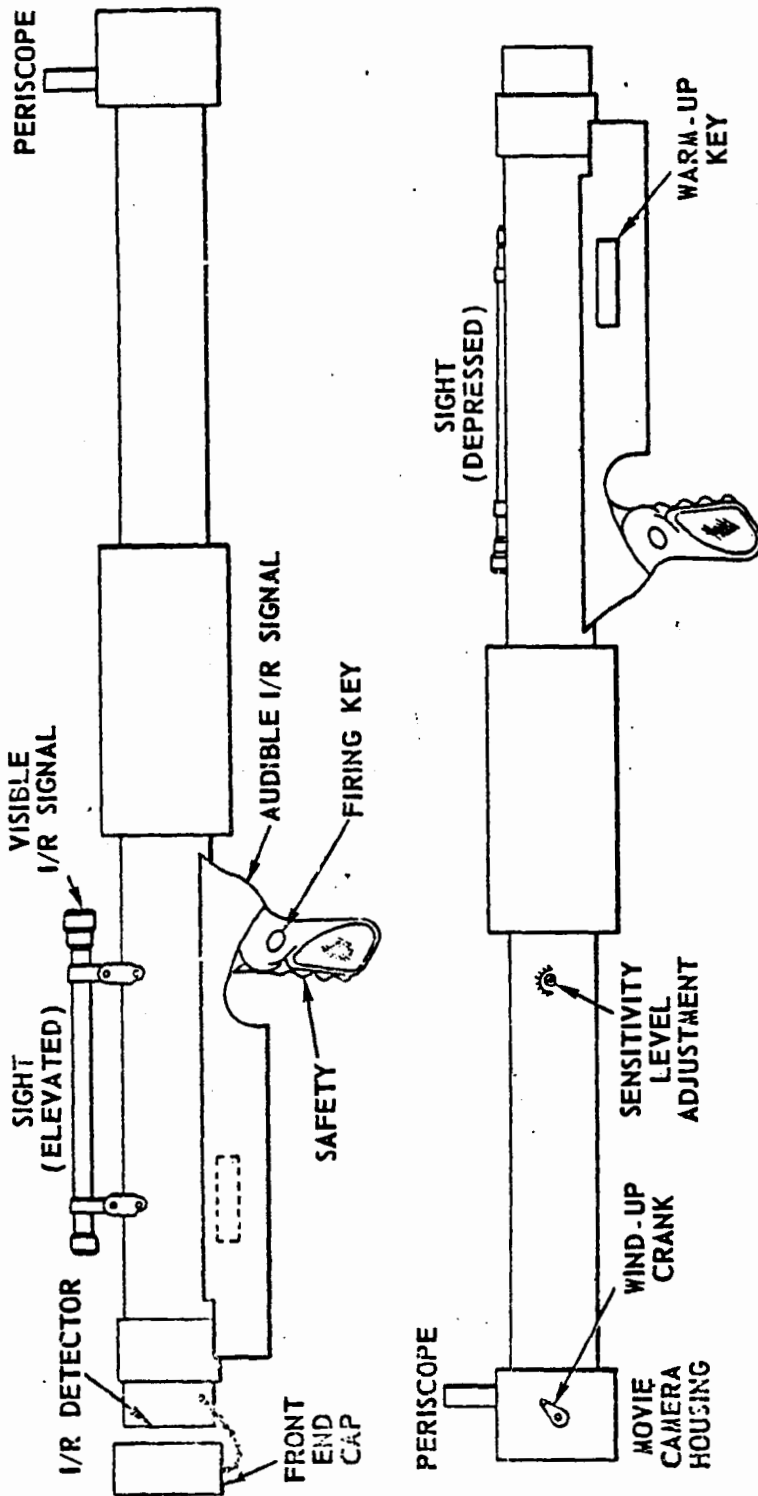

were conducted at the Combat Development Experimentation Center, Fort Ord, California. These tests showed that the REDEYE could be operated effectively by the average soldier.²⁴

Development Test Program—1960

(U) General Dynamics began the REDEYE development flight tests on schedule, in March 1960, but was unable to complete the 260-round program by the December 1960 target date because of technical difficulties. At the end of December, only 85 of the scheduled tests had been completed, many of them with disappointing results that contradicted the conclusions drawn from the feasibility demonstration firings. As stated earlier, the contractor development flight tests were conducted at NOTS, using the modified M-45 gun mount.

LTV-1 Firings

(U) The primary objectives of the LTV-1 firings were to evaluate propulsion system performance and investigate launch and in-flight roll rate histories and system aerodynamic qualities. The first 10 LTV-1 missiles, fired on 24 and 31 March 1960, were equipped only with the booster. Flight tests of rounds with the complete propulsion system (booster and sustainer motor) were delayed by the technical difficulties encountered in developing the sustainer motor.* They began on 24 June 1960 and were completed on 20 September 1960, with a total of 33 firings. The remaining seven rounds were reserved for later use. Two of them were expended, in November 1960, in special tests of a new tail fin design, bringing the total LTV-1 firings in 1960 to 45—10 with booster only and 35 with the complete propulsion system.

* See above, pp. 67, 69.

²⁴ ARGMA Diary, 1 Jan - 30 Jun 60, p. 83.

(U) Eighteen of the 35 firings were successful, 11 partially successful, and 6 unsuccessful. Four of the six unsuccessful flights were attributed to sustainer motor difficulties—three blew up at or immediately after launch with no data obtained and one was marred by a forward closure failure at sustainer ignition, with the case blown backward. The other two unsuccessful firings were special tests made in November to investigate aerodynamic stability with shrouds placed between the tail fins. Of the 11 partially successful firings, 9 exhibited erratic behavior because of improper missile roll rates and 2 were marred by sustainer motor trouble—1 blew up about 5 seconds after launch and the other failed to ignite after normal boost. The average maximum launch velocity was low at 85 fps; however, the LTV-1's weighed 17.2 lbs., compared to the 16 lbs. required, which would provide the desired launch velocity of 100 fps. The maximum flight velocity was slightly above the predicted 1,980 fps, with values averaging 2,025 fps.

(U) Missile roll rate control posed one of the most difficult technical problems of any encountered in REDEYE development. Flight tests conducted during the feasibility demonstration had indicated that the desired launch and in-flight roll rate could be achieved by means of canted booster nozzles and tail fins. But this tail design started giving trouble at the very outset of the development test firings in March 1960, when 4 of the 10 LTV-1 ejector-only rounds became unstable immediately after launch because of low roll rates. A subsequent investigation revealed that the low roll rates were caused by the impingement of booster exhaust gases on the tail fins. In May 1960, General Dynamics reported that the problem had been solved by the addition of blast deflection vanes near the booster nozzles. Despite the successful laboratory tests leading to this conclusion, the new configuration failed to produce the desired results. In June and

July, six LTV-1 rounds became unstable shortly after launch and executed violent maneuvers. Use of the blast deflectors was dropped in July, when an analysis of test data showed that the deflector vanes caused the ejector motor gases to deform the tail fins, increasing the cant angle and imparting excessive in-flight roll rates as high as 100 revolutions per second (rps). Further design changes notwithstanding, improper roll rates continued to cause random failures in LTV-1, LTV-1B, and GTV firings during the next 4 months. The search for an optimum tail configuration that would impart the desired launch roll rate without degrading the in-flight roll rate was still in progress at the end of 1960.

(U) The problem with motor case ruptures during the LTV-1 firings was later solved by an improved method of bonding the rocket motor inhibitor and the introduction of a one-piece case of H-11 steel. However, the test results indicated a sustainer ignition problem. In eight LTV-1 rounds which exhibited otherwise satisfactory performance, the sustainer ignition delay time was considerably shorter than the desired 0.25 second, the values ranging from 0.14 to 0.19 second. In another LTV-1 round and two of the LTV-1B rounds, the sustainer motor failed to ignite after normal boost owing to a lack of current to the squibs.

LTV-1B Firings

(U) The LTV-1B programmed maneuver flight tests, which were to have been completed during the period May 1960 to September 1960, began on 24 August and were yet incomplete at the end of December, with only 20 of the scheduled 50 rounds fired. Eleven of the 20 rounds successfully executed programmed maneuvers, 3 were partially successful, and 6 were unsuccessful. Of the six failures, the sustainer motor failed to ignite in two rounds, one followed a ballistic trajectory because of an internal wiring failure, and one became unstable 3 to 4 seconds after launch.

One of the three partially successful rounds exhibited erratic behavior and two failed to follow programmed maneuvers, although motor performance was satisfactory.

GTV-2 Firings

(U) The GTV's were complete missiles employing both guidance and control sections. Because of the problems encountered in developing the sustainer motor and failure of the booster to impart the desired spin rate to the missile, the initiation of GTV-2 firings was delayed from June to 23 September 1960. At the end of December 1960, only 20 of the 160 scheduled rounds had been flight tested at NOTS (19 of them Group 1A and the last one Group II). The target drones used for these firings was the KD2R5 augmented with 702A flares to provide an infrared source. The drones were flying at speeds ranging from 85 to 160 knots and an altitude of about 3,750 feet.

(U) In these tests, performance difficulties with the rocket motor gave way to problems with the IR seeker. The test objectives were definitely achieved in only 8 of the 20 firings. Two other tests appeared to be successful, but definite results could not be determined because the miss distance indicator in the target drone malfunctioned. Two of the eight rounds scored direct hits on the target drone. The first REDEYE missile to physically intercept a target was GTV Round 14, fired on 29 November 1960. It acquired the IR signal at launch, guided for 6.3 seconds, and intercepted the 100-knot drone at an altitude of 3,700 feet. The second intercept came on 21 December 1960, when Round 19 intercepted the 125-knot target at an altitude of 3,750 feet.

(U) Booster and sustainer motor performance was satisfactory in all 20 firings; however, in 1 round, fired on 21 October, the Teflon wedges used to hold the missile in place failed to release and both propulsion units burned in the launch tube. (This,

incidentally, was one of the safety hazards that had to be completely overcome before attempting a shoulder firing of the REDEYE.) Of the remaining nine unsuccessful firings, one was attributed to a firing pulse failure, one to loss of telemetry at launch, and the other seven to the loss of IR signal, aerodynamic instability, and/or deficient canard action. The continuing roll rate problem was particularly noticeable in Rounds 9 and 13, the former executing a severe right maneuver at 4.6 seconds and the latter starting a corkscrew maneuver after guiding for 6 seconds. The guidance and control problems were chiefly concerned with the non-linear autopilot; electronic noise in the IR seeker (a signal-to-noise ratio of 6/1 achieved against the desired ratio of 10/1); and the aerodynamic effects of rocket motor burnout which produced erroneous guidance commands because of the variation in accelerations.

(U) One of the first corrective measures taken was the replacement of the non-linear autopilot with a linear design to improve missile trajectory. To reduce electronic noise in the seeker and thereby improve sensitivity and tracking capability, General Dynamics and Philco decided to add an Automatic Cell Bias (ACB) circuit and a synchronous filter. Also, a K-Beta (KB) circuit was added to the guidance control section to counter the erroneous commands induced by rocket motor burnout. Drawings of these design modifications and of the latest tilted offset tail configuration were not released until April 1961, making it necessary to extend the delivery schedule for tactical prototypes. ²⁵

²⁵ (1) GD/P Tech Memo 360-287, 30 Jun 61, subj: REDEYE Rkt Mtr Dev & Test Hist, w App A, List of Static & Flt Tests. RSIC. (2) REDEYE Chronology & Fact Book. RHA Bx 13-230. (3) REDEYE Prog Repts, Mar - Dec 60. Hist Div File. (4) ARGMA Diary, 1 Jul - 31 Dec 60, p. 40. File same. (5) DF, Chf, AOMC Con Ofc to Distr, 6 Dec 60, subj: Mins of REDEYE Wpn Sys Mgr's Rept. File same. (6) ARGMA Hist Sum, 1 Jul - 31 Dec 60, pp. 111-14, 252-53.

The Abortive FY 1961 Procurement Program

(U) Despite the technical problems being encountered in mid-1960 and the resultant 3-month slippage in the development test program, ARGMA proceeded with the transition from R&D to production, as planned. The Agency effected the preliminary release to industrial in July 1960 and programmed FY 1961 PEMA funds to begin production with the interim design release in October 1960. On 18 August 1960, the REDEYE missile system was classified as Limited Production (LP). At the same time, plans were formulated for FY 1961 procurement of 1,700 missiles at a total estimated cost of \$11.8 million, including engineering services, tooling, and fabrication. This represented an estimated program unit cost of about \$6,900, but the unit cost in quantity procurement for FY 1965 was expected to drop to \$1,300. The unit cost of the .50-caliber heavy-barrel machine gun was \$772 and the M62 mount, \$281. However, replacement of the machine gun with the REDEYE would provide an incalculable improvement in kill probability and therefore was considered to be well worth the added cost.²⁶

(U) In view of the 3-month slippage in the R&D test program, which delayed the initiation of GTV-2 firings to 23 September 1960, AOMC recommended, in mid-September, that the industrial effort be deferred until after the REDEYE missile had been successfully demonstrated against aircraft-type targets and that the initial industrial deliveries be reduced from those originally planned. The proposed alternate plan called for the initiation of industrial action by late December or early January 1961, if the GTV-2 firings were successful and no further slippage occurred in the R&D program. The existing FY 1961 production plan called for 1,790 rounds to be delivered in 9 months, with initial delivery

²⁶OTCM 375i2, 18 Aug 60. RSIC.

to be 55 rounds per month and the maximum output rate of 1,000 rounds per month to be reached in 11 months. Under the proposed alternate plan, FY 1961 procurement would be about 900 rounds delivered over a 12-month period, with initial delivery to begin in January 1962 at the rate of 30 per month and the maximum output of 1,000 rounds per month to be attained in 20 months. The Ordnance Support Readiness Date of November 1962 would not be affected.

(U) These recommended changes in the production rate were predicated on development of the two-color IR seeker, which would be needed to meet full requirements of the REDEYE system. Preliminary evaluation indicated that the new seeker would provide an increased discrimination capability against targets with limited infrared radiation. If successful, it would not be ready for production release in time to appear in the first production models of the REDEYE, but would have to be phased in sometime during the FY 1962 procurement period. With the proposed procurement of a smaller FY 1961 quantity, a reduction in the initial delivery, and a slower build-up rate, improvements evolving from an industrial engineering effort could be evaluated and phased into production, thus delivering less rounds without improvements and more with better performance capability.²⁷

(U) While awaiting action on the alternate production plan, ARGMA effected the interim design release to production on 14 October 1960, but deferred the engineering release for procurement until December, when further GTV-2 demonstration tests would be completed. Because of this delay and administrative leadtime considerations, the Agency, in early November, requested that letter order authority be provided so that contracts could

²⁷Ltr, CG, AOMC, to CofOrd, 14 Sep 60, subj: Recmd Changes in the REDEYE Pdn Program. Hist Div File.

be issued at any time after 15 December. The items to be procured in the initial FY 1961 buy included 810 missiles and 9 months of engineering services effort.²⁸

(U) The revised Army Materiel Control Program (AMCP) of September 1960 indicated an enormous increase in program cost over that projected in the July 1959 AMCP. The estimate for the total program (including engineering, tooling, and fabrication) increased from \$11,347,000 for the original 1700-missile program, to \$12,470,000 for the reduced first-year buy of 810 missiles. The program unit cost increased from \$6,936 to \$15,400, and the estimated unit hardware cost from \$4,680 to \$7,432.²⁹

(U) The initial response to AOMC's alternate production plan was very disappointing. Unofficially, CONARC had already voiced its disapproval before the recommendation ever left AOMC Headquarters. Then, on 9 November, the Chief of Ordnance sent word that the Marine Corps was withholding its support of FY 1961 REDEYE procurement because of the large increase in unit cost.³⁰ In a briefing to representatives of OCO, on 29 November 1960,* ARGMA personnel outlined the current status of the program, restated the purpose and objective of the recommended alternate production plan, and reviewed the program funding requirements and cost trends. With regard to the latter, they stated that the total development cost through FY 1961 amounted to slightly less

* The same briefing was given to USMC on 30 November, to CONARC on 1 December, and to DA Staff on 2 December 1960.

²⁸ SS ORDXR-I-162, ARGMA Indus Ops, 2 Nov 60, subj: Req for Ltr Contr Auth, w TT ORDXR-IHP-1356, CG, AOMC, to CofOrd, 4 Nov 60. Hist Div File.

²⁹ DF, AOMC Con Ofc to Distr, 6 Dec 60, subj: Mins of REDEYE Wpn Sys Mgr's Rept. Hist Div File.

³⁰ Significant Item Rept, ARGMA Indus Ops, 14 Nov 60. Hist Div File.

than \$21 million, that the development program would be completed in December 1961 with FY 1961 funds, and that no improvement program was being considered except the two-color seeker. The basic reason for the large increase in system cost, they said, was that "more is now known about the system than was known 1½ years ago." Summarizing the presentation, COL John G. Zierdt, the Commander of ARGMA, said:

REDEYE is a very intricate missile system. In spite of its size and the simplicity of its operation, the system requires an application of technology which pushes the present state of the art. There have been setbacks, however, ARGMA is striving to overcome the difficulties by using those means at our disposal to minimize any additional technical or administrative hinderance to the program.

The system must be safe and reliable and consequently, it is not going to be as inexpensive as previously conceived. Further, it should be emphasized that Ordnance is taking a calculated risk in procuring tactical hardware prior to the completion of system safety qualification.

It has been shown that Industrial effort is scheduled to begin by January 1961. However, additional tests and firings must be made for further analysis of system performance to determine the advisability of proceeding with Industrial effort as planned. If there are further delays in development, the Industrial Program will likewise be delayed.

It is felt that the Ordnance Corps, through AOMC and ARGMA, is proceeding adequately to develop, produce, and maintain a highly effective weapon system desperately needed today by our Army and Marine Corps Combat Forces. Our optimism is not blind but is predicated upon a sound program utilizing the best in development engineering, production know-how, and support procedures.³¹

(U) At first, it appeared that the briefing had dispelled all objections to the recommended procurement plan. But, in the next few weeks, the program suffered a series of reversals which led to

³¹DF, AOMC Con Ofc to Distr, 6 Dec 60, subj: Mins of REDEYE Wpn Sys Mgr's Rept. Hist Div File.

major changes in development and production schedules. On 15 December, the Chief of Ordnance notified the ARGMA Commander that the Deputy Chief of Staff for Logistics (DCSLOG) had returned the Agency's request for letter order authority covering FY 1961 procurement, pending completion of action by the Materiel Requirements Review Committee.³² At about the same time, REDEYE engineers at ARGMA reviewed the results of GTV-2 flight tests and concluded that a sufficient confidence level to warrant release of hardware for production would not be reached until completion of the guided flights on 31 March 1961. The Agency Commander, on 21 December 1960, recommended that hardware procurement be deferred until 1 April 1961, but urged that the industrial engineering services effort be initiated in January 1961, as planned, in order to pave the way for industrial production and to minimize the chances of a slippage in the Ordnance Readiness Date.³³

(U) Nine days later, all hope of initiating industrial action in FY 1961 had completely vanished. With the test objectives definitely achieved in only 8 of the 20 GTV-2 rounds fired through 21 December, the Materiel Requirements Review Committee recommended that the FY 1961 REDEYE procurement program be cancelled. On 30 December, the DA Staff approved this recommendation and CONARC undertook a study to determine whether or not the program should be initiated in FY 1962.³⁴

³²TT ORDIZ-AR 12-244, CofOrd to CO, ARGMA, 15 Dec 60. Hist Div File.

³³SS ORDXR-I-260, 19 Dec 60, subj: Recmn for the REDEYE Program, w TT ORDXR-IH-1744, CG, AOMC, to CofOrd, 21 Dec 60. Hist Div File.

³⁴TT ORDIZ-AR 12-259, CofOrd to CG, AOMC, 30 Dec 60. Hist Div File.

CHAPTER V

ENGINEERING DESIGN REFINEMENT (U)

(U) The first half of CY 1961 thus found the REDEYE Commodity Manager closely observing the proof tests of system design refinements, surveying the damage done by deferment of FY 1961 procurement, and revising the RDTE and PEMA schedules accordingly. With unsolved technical problems still plaguing the contractor at the end of January, major changes were made in key target dates. The completion date for contractor guidance test firings (which had been extended from December 1960 to 31 March 1961) was slipped to 31 May, and the system demonstration (full propulsion, off-shoulder firings) and Design Release Inspection (DRI) were extended from April to June 1961. The interim release to production was scheduled for July 1961 and the final production release for December 1961. A subsequent revision extended the initiation of industrial effort (interim release) from July to 1 October 1961, the necessary funds for an engineering services contract and production contract to be provided by that date. The delivery of industrial prototype hardware was scheduled to begin in October 1962, followed by initial tactical hardware deliveries in August 1963. The Ordnance Readiness Date was extended from November 1962 to November 1963.¹

(U) In late March, the system demonstration was moved back from June to early July 1961, because of a delay in rocket motor deliveries for safety qualification tests. Since system

¹(1) TT ORDXR-RHA-30, CG, AOMC, to CofOrd, 31 Jan 61. (2) SS ORDXR-I-201, 7 Apr 61, subj: REDEYE Ord Readiness Date, w Ltr, CG, AOMC, to CofOrd, 14 Apr 61, subj: same. Both in Hist Div File.

demonstration hardware would have to be available for the DRI, this exercise was rescheduled from June to 24-28 July 1961.² Then, in late June, as pressure was applied to meet this heavy July schedule, the ARGMA Commander concluded that one of the two activities would have to be curtailed because of the limited contractor personnel available. On 26 June, the Military Requirements Review Committee decided to recommend production of the REDEYE to the DA Staff, subject to the achievement of a physical target intercept with a shoulder-launched missile.³ To assure a successful target intercept by mid-August 1961 and thus obviate another delay in the industrial program, it was essential that General Dynamics concentrate all available engineering manpower on the system demonstration task. Consequently, the DRI was postponed to 10-11 August 1961. The dates set for the interim release (1 October) and the Design Release Review (3-4 October) were unchanged.⁴

Compromise in the MC's

(U) Meanwhile, it became apparent from available flight test and laboratory data that the REDEYE system proposed for initial production with FY 1962 funds would be unable to meet certain performance requirements. Although design modifications in the guidance and control section greatly enhanced system performance capabilities, it was recognized early in 1961 that further refinements would be necessary to fulfill all of the MC's. The limitations inherent in the REDEYE missile were the product of

² (1) Ltr, CG, AOMC, to Cdr, ARGMA, 27 Mar 61, subj: DRI REDEYE, w 1st Ind, Cdr, ARGMA, to CG, AOMC, 3 Apr 61. (2) SS ORDXR-CW-21, 31 Mar 61, subj: same. Both in Hist Div File.

³ TT, CofOrd to CG, AOMC, 7 Jul 61. Hist Div File.

⁴ SS ORDXR-R-682, 30 Jun 61, subj: DRI REDEYE, w Ltr, Cdr, ARGMA, to CG, AOMC, 30 Jun 61, subj: same. Hist Div File.

UNCLASSIFIED

~~CONFIDENTIAL~~

three basic shortcomings: it could not go fast enough, it could not maneuver soon enough, and it could not discriminate well enough. A summary of the capabilities and limitations predicted for the production system follows.

(S) Performance: Target speeds of from 0 to 600 knots were required; however, the system would be effective only against targets up to 400 knots, at slant ranges from 2,000 to the required 4,100 meters, to altitudes in excess of the desired 9,000 feet, and maneuvering at 6 g's within these envelopes.

(U) Type Targets: The majority of the required targets had sufficient radiant intensity to permit engagement at maximum effective range through most aspect angles. Those targets of the OQ-19 and L-19 type could be engaged at reduced ranges. A severe system degradation would occur, however, when either celestial or terrestrial background was of sufficient radiant intensity to override the target signal. This would occur largely with those targets of reduced intensity, such as small helicopters, liaison aircraft, and at certain aspects of larger aircraft.

(S) Kill Probability: (Required 0.5) Although sufficient data had not been accumulated for a very accurate estimate, it was predicted that a circular probable error of 6 feet would be attainable. (The single-shot kill probability was later established at 0.3 against high-performance jet aircraft and 0.5 against other aircraft within specified speeds, altitudes, and ranges.)

(U) System Weight: The complete production system (missile and launcher) was expected to weigh about 22 pounds, 2 pounds more than the maximum stated in the MC's. The biggest contributors to the increased weight over the 19.6-lb. engineering model was the steel motor case and more complex launching system. (The weight of the tactical system later increased to 29.3 pounds, but this was not considered judicious cause for rejection for military use.)

(U) To eliminate the shortcomings in the system and fulfill all user requirements, five basic design refinements would be required. Three of these dealt with improvements in maneuverability: a hemicone infrared dome to reduce drag; an optimum launch lead angle to reduce required maneuvers; and a dual thrust rocket motor to improve missile velocity and effective intercept

~~CONFIDENTIAL~~

UNCLASSIFIED

range. To improve discrimination against background and targets of low radiant intensity, the spectrum of seeker operation would be changed to either a cooled detector or the two-color seeker (the basic system used an uncooled lead sulfide detector). Terminal guidance accuracy would be improved by using variable incidence (instead of fixed) canards. It was estimated that the design, fabrication, test, and evaluation of these refinements would require a minimum of 24 months and RDTE funding in the amount of \$10 million. As stated earlier, development of the basic REDEYE was due for completion in CY 1961 with expiration of FY 1961 funds. The \$1.5 million in RDTE funds planned for FY 1962 essentially provided only for service test hardware.

(U) Although still in development, not yet fully qualified for production, and subject to the limitations mentioned above, the capability of the basic REDEYE was still far superior to any potentially available low-altitude air defense system. With this man-portable weapon, combat troops would have the potential of inflicting heavy damage upon low-altitude enemy aircraft, forcing them to higher altitudes where they would be vulnerable to the HAWK and MAULER systems. The only aircraft capable of evading the REDEYE would be the extremely low-flying vehicles of marginal radiant intensity and those with speeds in excess of 400 knots, or of such size as to escape visual detection.

(U) The Commanding General of AOMC therefore recommended, in April 1961, that the version of the REDEYE then under development be produced, commencing in FY 1962, in those quantities necessary to fulfill priority user requirements. This action, of course, would be subject to a satisfactory system demonstration and CONARC and Marine Corps approval of the existing system capabilities. He further recommended that the REDEYE improvement program be initiated on a non-interference basis with the basic REDEYE and on a time schedule to permit thorough development and

evaluation before the incorporation of design changes into the tactical weapon system.⁵

(U) MAJ H. L. Claterbos, of ARGMA R&D Operations, briefed the Chief of Ordnance on the foregoing system status and recommendations, on 12 April 1961, and followed this with a presentation to representatives of the DA Staff, CONARC, and Marine Corps, on 20-21 April. The Chief of Ordnance approved essentially all aspects of the program, but expressed concern over the lack of an IFF^{*} capability in the system. User representatives informally agreed to waive the MC's to accept the basic REDEYE. While funding for the proposed improvement program was nebulous, all concerned agreed that all or at least a portion of it should be undertaken, and that such a program should be separate from production of the basic system.⁶

(U) In May 1961, CONARC and the Marine Corps officially acknowledged the shortcomings in the basic REDEYE and agreed to accept, on an interim basis, a weapon system which did not fully meet all requirements of the MC's, but which would have effective performance capabilities within the limits stated above.⁷

* Identification, Friend or Foe. The REDEYE had no electronic equipment to perform the IFF function. Instead, target detection was done visually by the operator. This method had not been put to a true test in REDEYE firings. All target drones used so far had been painted bright red and equipped with flares, and firings had been conducted only in bright daylight.

⁵(1) 1st Ind, Cdr, ARGMA, to CG, AOMC, 10 Feb 61, on Ltr, CG, AOMC, to Cdr, ARGMA, 27 Jan 61, subj: REDEYE MC's. (2) Ltr, CG, AOMC, to CofOrd, 11 Apr 61, subj: REDEYE Dev Program. (3) REDEYE Presn to CofOrd by MAJ H. L. Claterbos, 12 Apr 61. All in Hist Div File.

⁶Trip Rept, MAJ H. L. Claterbos, 25 Apr 61. Hist Div File.

⁷TT ATDEV-4 805064, CG, CONARC, to CofOrd, 10 May 61; & TT, USMC to CofOrd, 12 May 61. Cited in REDEYE PM₂P, 31 Dec 66, p. 1.

Missile Design

(U) General Dynamics spent the first part of 1961 fabricating and proof testing missile design refinements aimed at solving the problems disclosed by the initial GTV-2 firings in 1960. From 1 January through 30 June, 66 contractor development test missiles were launched from the modified M-45 gun mount at NOTS, including 39 full-propulsion GTV-2's, 5 LTV-1B's, and 22 LTV-1's. The 27 LTV-1/1B rounds were fired to evaluate roll rate patterns induced by different tail designs. Four of the 39 GTV-2 rounds were fired against 200-knot F6F target aircraft; the others against KD2R5 (OQ-19-type) targets having speeds of 80 to 170 knots. All of the target drones had T-131 and/or 702A flares to augment IR radiation. At the end of June, 18 engineering model (GTV-2) missiles remained to be fired under the contractor development test program at NOTS. These 18 firings, to include the first Group IVA missiles with live warheads, were scheduled for completion by the end of August 1961.⁸

Roll Rate Problem

(U) During the first 2 months of 1961, General Dynamics continued the rocket motor test program, with live ejector launch tests and tethered sustainer firings, in the search for an optimum tail configuration that would impart the desired initial (launch) roll rate without degrading the in-flight roll rate. The immediate objective of the research firings was to investigate methods of increasing the launch roll rate to the desired 13-15 rps. Experiments conducted in January indicated that the problem had been partially solved with ejector nozzle extensions and exhaust deflectors, this innovation producing a launch roll rate of

⁸ (1) ARGMA Hist Sum, Jan - Jun 61, p. 54. (2) REDEYE Prog Repts, Jan - Jun 61. Hist Div File.

12 to 14 rps. Another innovation, explored in February, was a design with offset tails tilted in their stowed position in the launch tube, so that the expanding booster gases would impart a rolling moment to the missile. Laboratory experiments with these different designs indicated that either the blast deflectors canted at -5° or 0° , or the offset tilted tail design would give the missile an initial roll rate of the desired value.

(U) In March, 10 LTV-1 rounds were fired to determine the effect of these and other tail designs on launch and in-flight roll rates. Satisfactory launch roll rates were achieved on missiles with either boost blast deflectors or the tilted tails. One missile with boost blast deflectors and one with asymmetrical tail fairings exhibited satisfactory in-flight roll rates. The data obtained from at least two of the firings thus indicated that the boost and in-flight roll rate problem had been solved—the former by canted blast deflectors and the latter by the two-piece tail design with asymmetrical fairings. On the strength of these test results, General Dynamics released the modified design drawings, in April, for incorporation in the 80 tactical prototype missiles then being fabricated.

(U) Additional LTV-1 and 1B flight tests, in April, gave further evidence that the asymmetrical offset tail design and boost blast deflectors had solved the roll rate problem, but the results of two GTV-2 missile firings failed to verify this. Both of the GTV-2's had satisfactory initial roll rates but in-flight rates were too high on one and too low on the other. In the first round (SN 451—the first Group III test missile with improved seeker), excessive roll rates caused the control surfaces to remain extended and the missile lost guidance at 3.5 seconds. In-flight roll rates on the second round declined to 2.5 rps at 2.5 seconds. Roll pitch coupling caused the missile to become unstable and lose the IR signal at 3 seconds.

(U) In May, the contractor fired 10 more GTV-2 missiles for further evaluation of the tail design and performance of the redesigned seeker and guidance control section. These firings generally confirmed the ability of the tail design to provide satisfactory initial roll rates, but the peak in-flight roll rates ranged from 18.5 to 20 rps, in contrast to the desired rate of 16 rps. Five of the 10 flight tests were considered satisfactory, in that the missiles were successfully guided within an acceptable distance of the target; however, most of these rounds still had improper roll rates. Of the remaining five rounds, one exhibited erratic autopilot operation and lost the IR signal at 1.5 seconds; two had excessive in-flight roll rates and lost guidance at 2.8 and 3 seconds, respectively; one became unstable at 3 seconds owing to roll pitch coupling; and one was marred by low roll rate and jammed control surfaces, the missile losing the IR signal and making an erratic maneuver away from the target at 2.8 seconds.

(U) Determined to prove the feasibility of the tilted tail design in guided flights, the contractor returned to the test range on 5 June and fired six more GTV-2 rounds. Two of these had fairly small miss distances of 13 and 22 feet, respectively. Two others were considered successful, but had miss distances of more than 100 feet. Of the other two missiles, one experienced a sustainer ignition failure and one performed a sharp maneuver at 3 seconds and went ballistic.

(U) Since the offset asymmetrical tail design did not provide consistently satisfactory roll rates, the contractor fabricated and tested nine LTV-1 missiles with different tail designs, during the period 10 to 28 June 1961. Five of the nine rounds with tail mounting hubs extending into the sustainer exhaust cone had satisfactory roll rate patterns. Two LTV-1B missiles were then fired, on 28 June, to determine if this

configuration would induce proper roll rates for maneuvering missiles. And again, the results were disappointing—peak sustainer phase rates were satisfactory, but initial roll rates were below acceptable tolerance.⁹ Further evaluation tests of the tail mounting hub design were conducted in July, as part of the R&D test program in support of the system demonstration.

Rocket Motor Problems

(U) Major deficiencies in rocket motor performance appeared to be corrected and all items of hardware, except the convergent cone with an "O" ring seal, were produced according to final design specifications. In January 1961, Norris-Thermador, manufacturer of the one-piece motor case, encountered a serious production problem stemming from a defective batch of H-11 steel. The steel mill replaced the faulty material in April, and production of motor cases with H-11 steel was resumed in May. Meanwhile, Norris-Thermador shifted to an alternate steel (Aerojet AMS 6434) as a stopgap measure. However, the time required to locate and procure an acceptable substitute led to a delay in motor case deliveries to the Atlantic Research Corporation and a corresponding slippage in delivery of rocket motors for safety qualification tests. It was this delay that caused the system demonstration to be postponed from June to July 1961.

(U) At the end of June, Norris-Thermador had completed its obligations under the REDEYE R&D program, with delivery of 1,050 motor cases (including 150 made with 6434 steel). The Atlantic Research Corporation had delivered 504 rocket motors as of 30 June 1961. The delivery schedule called for delivery of 446

⁹(1) REDEYE Prog Repts, Jan - Jun 61. (2) ARGMA Diary, Jan - Jun 61, p. 96. (3) ARGMA Hist Sum, Jan - Jun 61, pp. 47-50. All in Hist Div File.

more by the end of September, to complete the order of 950.¹⁰

Guidance and Control Refinements

(U) The design refinements made in the guidance control section were aimed at correcting deficiencies bared by the initial GTV-2 firings in 1960. To improve missile trajectory, General Dynamics replaced the non-linear autopilot with a linear design, which was completed and ready for test in January 1961. In an effort to reduce electronic noise and thus improve seeker sensitivity and tracking capability, an Automatic Cell Bias circuit and a synchronous filter were added to the IR seeker. Finally, a K-Beta circuit was added to counter the erroneous guidance commands induced by rocket motor burnout. The drawings for these design refinements were released in April 1961 for incorporation in the 80 tactical prototype missiles, which were scheduled for delivery beginning in June 1961.

(U) General Dynamics test fired the first Group III GTV-2 missile (SN 451) with the improved seeker on 7 April. The telemeter record showed a vast reduction in seeker noise and a corresponding improvement in seeker tracking signal; however, as noted above, the flight was marred by excessive in-flight roll rates. Sixteen GTV-2 firings, in May and June 1961, confirmed improvements in seeker performance, but many of them were the victim of improper roll rates and other component malfunctions.¹¹ A meaningful evaluation of the final missile design to be released for production in October 1961 would have to await a satisfactory solution to the roll rate problem.

¹⁰ *Ibid.*, pp. 50-51.

¹¹ (1) *Ibid.*, pp. 51-54. (2) Ltr, CG, AOMC, to CofOrd, 17 Jan 61, subj: REDEYE Tech Eval Rept. Hist Div File.

Tactical Prototype Delivery Schedule

(U) As a result of the difficulties encountered in solving the missile roll rate problem and in making the required seeker modifications, the delivery schedule for the 80 tactical prototype missiles had to be extended. As late as 31 May, the contractor was confident that the remaining problems could be solved in time to meet the delivery schedule; i.e., the first 20 in June and 20 each in July, August, and September. But with these problems yet unsolved at the end of June, the schedule was extended to provide for completion of the first 15 tactical prototypes in August, 35 in September, and 30 in October 1961.

(U) The delivery schedule for tactical prototype launchers and field testers was also extended. The revised plan called for delivery of the first 3 launchers in July, 21 in August, 33 in September, and 23 in October 1961. Delivery of the first missile system field tester was extended from June to late July. The second tester was slated for completion in August instead of July. The field maintenance test set was designed to allow the missile system and the 3-G-84 trainer to be checked without disassembly.¹²

Proof Tests of the Tactical Shoulder Launcher

(U) Meanwhile, General Dynamics completed four engineering models of the tactical shoulder launcher, leaving 22 to be assembled by 30 September 1961. One of these was mounted on the M-45 gun mount at NOTS for evaluation firings preparatory to the first shoulder launching test. The gun-mounted launcher was used in two ejector-only REDEYE firings in mid-April. Operation of the launcher was excellent in both tests, no deterioration of the

¹²(1) ARGMA Hist Sum, Jan - Jun 61, pp. 56-57. (2) ARGMA Diary, Jan - Jun 61, pp. 95A, 96. Hist Div File.

tube or other parts being noted.

(U) On 18 May 1961, CPT Dale Huddleston, a Marine Corps officer, conducted the first ejector-only shoulder firing of the REDEYE missile, using the second engineering model of the tactical launcher. He suffered no ill effects from noise, recoil or heat. Several more attempts to fire ejector-only missiles were unsuccessful owing to a malfunction of the battery firing mechanism.

(U) After correction of the deficiency in the firing mechanism, two more ejector-only rounds were shoulder-fired on 5 June—one by CPT Huddleston and one by MAJ H. L. Claterbos. Both of these firings were successful, the operators suffering no detrimental effects from noise, recoil, or heat.¹³

Firings in Support of the System Demonstration

(U) During the first few weeks of July 1961, the contractor concentrated virtually all of his engineering effort on the fabrication and test of nine additional R&D rounds in support of the system demonstration. These firings were required to verify the solution to the roll rate problem; to demonstrate performance of the improved control and seeker sections and the tactical shoulder launcher with seals and telescopic sight; and to qualify the complete, full-propulsion system for shoulder firing. To allow time for the support firings, the beginning of the system demonstration was extended from early July to the week ending 21 July. It was then delayed another week because of three failures in the motor qualification tests at White Sands. While a safety analysis indicated that the three motor ruptures would

¹³(1) *Ibid.*, p. 95A. (2) ARGMA Hist Sum, Jan - Jun 61, p. 56. (3) DF, Chf Engr, REDEYE Br, RDO, to ARGMA Con Ofc, 16 Aug 61, subj: Shoulder Firing of REDEYE. (4) GD/P REDEYE Monthly Rept for Jul 61, p. 2. All in Hist Div File.

not have been hazardous to the operator, the NOTS Safety Committee withheld approval of complete weapon shoulder firings pending static test of 30 additional motors.

(U) The nine-round test program commenced on 7 July and ended on 26 July 1961. Shoulder firings of three ejector-only test vehicles successfully demonstrated performance of the tactical launcher with environmental glass seals and telescopic sight. The results of one LTV-1, two LTV-1B, and two GTV-2 firings from the gun-mounted tactical launcher indicated that the desired minimum and maximum missile roll rates could be achieved by a 2-inch tilted offset tail design with a wedge in the tail mounting hub. Both of the GTV-2 rounds had satisfactory roll rates, but large miss distances. The first one had the IR signal through intercept at 6.8 seconds, with a miss distance of 153 feet. The second round lost target lock at 3.8 seconds, because of a faulty relay in the launcher, and missed the target by more than 950 feet.

(U) The first shoulder firing of a ballistic round (LTV-1) with both the booster and sustainer motor took place at NOTS in the final support firing on 26 July. Loss of telemetry at 1.8 seconds prevented an evaluation of roll rate history. The missile hit the ground shortly after sustainer ignition, spun for a few seconds, then took off again, landing about 2,400 feet behind the launch site. The operator suffered no adverse effects from the sustainer ignition. Another similar firing was cancelled.¹⁴

The System Demonstration

(U) As originally planned, the system demonstration program

¹⁴ (1) *Ibid.*, pp. 2-3. (2) Naval Speedletter 0775, NOTS to CofOrd, *et al.*, 12 Jul 61. (3) REDEYE Prog Rept, Jul 61. (4) TT ORDXR-RHA-477, CG, AOMC, to CofOrd, 14 Jul 61. (5) ARGMA Hist Sum, Jun - Dec 61, pp. 50-55. All in Hist Div File.

embraced a total of 36 firings, including 16 engineering model (GTV-2) missiles with the latest design refinements, and up to 20 tactical prototype missiles. Five of the 16 GTV-2 rounds were to be equipped with telemetered warheads (Group IVB) and the remaining 11 rounds with live warheads (Group IVA). The plan was to complete the GTV-2 firings by 11 August, the date set for the Design Release Inspection. To be considered successfully demonstrated and acceptable, the weapon system would be required to meet the following criteria:¹⁵

1. Eight of the 16 GTV-2 missiles come within less than 10 feet of the hottest point on the target. (Physical intercept of the target by a GTV-2 Group IVB missile and penetration of the missile into the target structure would be considered a kill.)

2. Adequate warhead effectiveness against droned full-size aircraft.

3. Thirty percent of the tactical prototype rounds fired come within 6 feet of the hottest point on the target.

4. Destruction of droned F6F reciprocating engine aircraft, F9F jet aircraft, and H-13 helicopter targets.

(U) The moment of truth for the trouble-ridden REDEYE arrived with the first system demonstration shoulder firing of a full-propulsion GTV-2 missile on 27 July 1961. It will be recalled that the DA Materiel Requirements Review Committee, in June, had decided to recommend production of the REDEYE, subject to the achievement of a physical target intercept with a shoulder-launched missile. Emphasizing the extreme importance thus attached to the system demonstration, the Chief of Research & Development wrote the Chief of Ordnance:

. . . [It] is imperative to the REDEYE program that this demonstration show conclusively, by actual destruction of targets,

¹⁵TT ORDXR-RHA-477, CG, AOMC, to CofOrd, 14 Jul 61. Hist Div File.

that REDEYE has the capability to engage successfully jet and prop-driven aircraft and helicopters. . . .

Although timely initiation of the system demonstration is important, it is considered that the controlling factor should be maximum assurance of success. . . .¹⁶

(U) Earlier indications were that the 1-week delay in initiating the program could be made up to permit completion of the 16 GTV-2 firings the week of 11 August, as scheduled. This optimistic goal was not attained. Indeed, only 7 of the 16 rounds had been fired as of 16 August and not one of them met the criteria for a successful system demonstration. All seven of these rounds were Group IVB (telemetered) missiles and all were shoulder-fired against flare-augmented KD2R5 targets flying an outbound-quartering course at an altitude of about 2,000 feet and speeds of 148 to 172 knots.

(U) The first three firings were scored "no test" (invalid test or personnel error). The first attempts to fire Missile 517, on 27 July, were foiled by a launcher battery firing mechanism failure. Upon application of an external power source, the ejector prematurely ignited. The fuze did not activate and the sustainer motor was not fired. Missiles 522 and 526 both lost the target acquisition signal at zero time and went ballistic because the operator released the gyro-uncage switch just before firing.

(U) Missiles 518 and 520, fired on 10 August, successfully acquired the IR signal, but missed their targets by more than 200 feet. The last two rounds (Missiles 515 and 516) were fired on 16 August, with much the same results, one missing the target by 92 feet and the other by 415 feet. The minimum and maximum roll

¹⁶DF to CofOrd quoted in TT, CofOrd to CG, AOMC, 7 Jul 61. Hist Div File.

rates were lower and higher than desired on all four rounds.¹⁷

(U) The large miss distances recorded in these tests indicated that the existing system design would not fully meet the modified MC's. Consequently, further GTV-2 firings were suspended pending completion of a detailed aerodynamic analysis of the missile and the incorporation of adequate design fixes.¹⁸

Design Release Inspection and Schedule Revision

(U) Representatives of ARGMA apprised an AOMC team of the current status of the weapon system during the Design Release Inspection (DRI) held on 10-11 August 1961. The comments and recommendations resulting from this inspection pinpointed a number of design deficiencies which would have to be corrected before the initiation of an industrial program. Among these were improper missile roll rates, lack of missile stability and maneuverability, and inadequate IR seeker sensitivity to detect aircraft at the required range limits.

(U) Guided by the data presented at the DRI and a thorough evaluation of the demonstration firings through 16 August, the Deputy Commanding General of AOMC again postponed the industrial program and requested an extension of 5 months in the RDTE effort to solve technical problems. The revised program schedule approved in September 1961, extended the interim design release from October 1961 to January 1962, and the final design release from December 1961 to April 1962. The system demonstration was

¹⁷(1) GD/P REDEYE Monthly Repts for Jul & Aug 61. (2) REDEYE Prog Repts, Jul & Aug 61. (3) TT ORDXR-C-255-61, Cdr, ARGMA, to CofOrd, 22 Nov 61. (4) DF, Chf Engr, REDEYE Br, RDO, to Chf, Con Ofc, 16 Aug 61, subj: Shoulder Firing of REDEYE. All in Hist Div File.

¹⁸(1) GD/P REDEYE Monthly Rept for Aug 61. (2) REDEYE Prog Rept, Aug 61. Both in Hist Div File.

moved back to January 1962 and the Design Release Review from October 1961 to early February 1962. The Ordnance Readiness Date (November 1963) was unchanged.¹⁹

(U) To permit the incorporation of design changes resulting from the dynamic analysis, the schedule for completion of the 80 tactical prototype missiles was also extended. The revised schedule called for the delivery of 17 in January, 27 in February, and 36 in March 1962.²⁰

(U) As a result of the stretchout in development effort, which was to have been completed in December 1961, the RDTE funding requirement for FY 1962 was increased from the original estimate of \$1,575,000 to \$5,400,000. Program authority was later approved for \$5,055,000 of that amount. This additional funding was based upon an optimistic schedule which reflected the urgency of the demand for completion of the task and a non-parallel engineering approach to solution of the various technical problems. Chief among these were missile roll rate, accuracy or miss distance, seeker sensitivity, and background rejection.²¹

Weapon System Analysis

(U) Shortly after the suspension of system demonstration firings in mid-August, General Dynamics began an intensive

¹⁹ (1) Ltr, DCG, AOMC, to Cdr, ARGMA, 8 Sep 61, subj: Critique of REDEYE DRI, w incl: REDEYE DRI Cmts. (2) REDEYE Cmdty Plan, Rev M, 30 Sep 61. (3) REDEYE Chronology, 11 Oct 61. (4) TT ORDXR-RHA-593, Cdr, ARGMA, to CofOrd, Aug 61. All in Hist Div File.

²⁰ (1) *Ibid.* (2) GD/P REDEYE Monthly Rept for Aug 61. Hist Div File.

²¹ (1) REDEYE Prog Repts, Jul-Sep 61. (2) REDEYE Program Sta Rept, ARGMA, 7 Sep 61. (3) Recmd Emerg Fund Just Sheet, ADGM Sys, REDEYE, atchd as Incl 2 to Ltr, DCG/GM, AOMC, to CofOrd, 21 Dec 61, subj: Revised REDEYE Program. All in Hist Div File.

analysis of the REDEYE system, in an effort to isolate the causes contributing to the problem areas. The first phase embraced a complete dynamic analysis of the missile, with analog and digital computer simulations of the missile and computer simulations of the seeker. The second phase consisted of an aerodynamic investigation of missile roll rate and maneuverability. Coincident with the latter effort, the contractor made a detailed analysis of the IR seeker, the need for this study resulting from the fact that only about 10 percent of the IR cells in the seekers were meeting the established sensitivity specifications. The problem of background rejection received minimum effort, partly because of a funding shortage and partly because of the previous acceptance of the degradation caused thereby.²²

Seeker Sensitivity

(U) Since the original seeker sensitivity specifications were predicated upon an advance in the state of the art not yet fully realized, the contractor made a detailed study of the factors influencing cell sensitivity and prepared an IR cell specification delineating the revised parameters. The cell requirements were presented in physical, chemical, and electrical terms, rather than the electrical terms used in the previous cell specification.

(U) Purchase orders for 200 IR detection cells meeting the revised specifications were placed with the Electronics Corporation of America and Infrared Industries, in October. The Electronics Corporation delivered the first 13 detection cells in November, and all of those tested successfully met the revised specifications. The initial cells delivered by Infrared Industries failed to meet the specifications.

²²(1) *Ibid.* (2) GD/P REDEYE Monthly Rept for Aug 61. Hist Div File.

Miss Distance Investigation

(U) Preliminary results of computer simulations revealed four possible areas which, individually, would not have caused the large misses, but, when combined, would have. These were excessive tip-off rate at launch, excessive delay in sustainer ignition, failure to introduce the required 10° superelevation, and an increase in stability owing to the tail panel redesign.

(U) General Dynamics made analog computer studies of the off-center null reticle, modified SIDEWINDER, IR dual-band reticle, and the SD-3 reticle. The results of these studies indicated that the off-center null reticle might be unsuitable for use in the REDEYE in its existing form. Effort was then concentrated on a dynamic simulation of the existing system using the SD-3.

(U) Analog computer studies of the soft limiter circuit revealed that this circuit would compensate for tracking loop oscillations during the terminal stages of flight. Further tests would be required to determine the exact time parameters for the wide-band circuit.

Roll Rate Investigation

(U) As a part of the overall investigation of the miss distance problem, aerodynamic studies were conducted to establish a tail configuration capable of providing a roll rate pattern compatible with missile design characteristics. Using the data collected in wind tunnel tests, the contractor fabricated and fired 18 flight test missiles (5 LTV-1B's and 13 LTV-1's) with different cambered designs. The conclusions reached from these tests indicated that 1.9-inch tails with 1.25 percent camber and 0.8° cant would provide the desired roll rate; however, the tail mounting hubs induced a greater stability than former configurations. The greater part of the roll rate problem was thus thought

to be solved by the use of cambered tails, but fine adjustments, through trial and error, were yet necessary for a complete solution.²³

Accelerated Firing Program

(U) The progress made in the system analysis through September 1961 showed good promise of meeting the revised schedule, which called for resumption of GTV-2 firings in November. However, in mid-October, the contractor's engineering effort was interrupted to carry out a special firing program imposed by higher headquarters. In a message to AOMC, on 12 October, the Chief of Ordnance directed that immediate action be taken to fabricate and flight test from two to five complete REDEYE missiles of the latest design to determine the adequacy of fixes. This accelerated firing program was to be accorded top priority, regardless of the effect on the current development effort.²⁴ Coincident with this action, the REDEYE made its first public appearance in a special weapons demonstration at Fort Bragg, North Carolina. (See accompanying photograph.)

(U) As can be seen in the foregoing brief of the system analysis, the design fixes in October were based largely on incomplete computer and dynamic tests, and were not properly definitized to permit installation in complete warhead rounds. Moreover, the safety requirements for shoulder firing complete warhead rounds had not been established, the system demonstration firings having been suspended short of that point in the program. Consequently,

²³ (1) GD/P REDEYE Monthly Repts for Aug-Oct 61. (2) REDEYE Prog Repts, Nov-Dec 61. (3) ARGMA Diary, 1 Jul - 11 Dec 61, p. 109. All in Hist Div File

²⁴ (1) TT DA 904027, CofOrd to CG, AOMC, 12 Oct 61. (2) TT, same to same, 23 Oct 61. Both in Hist Div File.



ARMY LIEUTENANT SHOULDER FIRES THE REDEYE FOR THE PRESIDENT
1LT Francis M. Dongieux, Jr., successfully fired the REDEYE missile in its first public appearance on 12 October 1961, during a special weapons demonstration at Fort Bragg, N. C. LT Dongieux, a member of the REDEYE project staff at ARGMA, shoulder-fired the missile without the usual body armor and face protection worn in tests. The above enlargement, taken from data motion picture film, shows the REDEYE missile in flight just leaving the launch tube. Because of range limitations, the firing was of an unguided (LTV-1) missile. Witnessing the demonstration were some 300 spectators, including President John F. Kennedy, Defense Secretary Robert S. McNamara, and Army Secretary Elvis J. Stahr, Jr. (ARGMA News Summary 247-61, 13 Oct 61; and *The Redstone Rocket*, 20 Dec 61.)

three LTV-1 and six GTV-2 firings were mandatory to establish fixes and safety requirements. One complete GTV-2 round (Missile 504) was then shoulder-fired against a drone without flare augmentation for additional guidance verification. The five DA-directed firings were conducted at San Nicholas Island, on 1-2 November, to determine the adequacy of fixes and overall system capability.²⁵

(U) As shown below, the GTV-2 support tests included three Group IVB telemetered missiles and four Group IVA missiles with live warheads. The first six rounds had the T38 tail design with 1.25 percent camber. The last test missile had a tail span of 1.9 inches with 1.25 percent camber and 48-minute angle.

<u>Missile Nr & Gp.</u>	<u>Date Fired</u>	<u>Type Launcher</u>	<u>Target Data</u>			
			<u>Type</u>	<u>Speed</u>	<u>Altitude</u>	<u>Flare</u>
502/IVA ^{a/}	10-19-61	M-45 Mt.	F6F	165 k	4,150 ft	702A
519/IVB	10-19-61	Shoulder	KD2R5	160 k	2,000 ft	702A
501/IVA	10-27-61	M-45 Mt.	KD2R5	143 k	2,050 ft	702A
503/IVA ^{b/}	10-27-61	Shoulder	KD2R5	143 k	2,050 ft	702A
525/IVB	10-27-61	Shoulder	KD2R5	143 k	2,050 ft	702A
527/IVB	10-27-61	Shoulder	KD2R5	143 k	2,050 ft	702A
504/IVA ^{c/}	11- 1-61	Shoulder	PB4Y2K	140 k	3,000 ft	None

^{a/} First GTV round tested with live warhead.

^{b/} First shoulder firing of GTV with live warhead.

^{c/} First GTV firing against target without flare augmentation.

(U) All seven of the preliminary test rounds were successfully launched and the objectives of establishing design fixes and safety requirements were achieved. The guidance accuracy of the system, however, still left a lot to be desired, as six of the

²⁵ TT ORDXR-RHA-792, CG, AOMC, to CofOrd, 17 Nov 61. Hist Div File.

missiles missed their target by more than 200 feet. Missile 503-- the first complete round with live warhead to be shoulder-launched-- scored a close miss of 20 feet. Though required for the regular program, these firings were premature and of little value to normal development.²⁶

(U) The five DA-directed firings consisted of one GTV-2 Group IVA round (SN 505) and four tactical prototype rounds (SN 711, 712, 717, and 719), the latter representing the interim tactical design. The tail configuration used was the 1.9-inch span with 1.25 percent camber and 48-minute cant angle. All of the missiles were shoulder-fired against 140-knot PB4Y2K targets, without flare augmentation, flying a crossing course. The target altitude was 3,000 feet for Missiles 711 and 712, and 4,720 feet for Missiles 505, 717, and 719.

(U) Missiles 711 and 712, fired on 1 November 1961, lost the IR signal soon after launch and went ballistic. The difficulty in acquisition was traced to the asymmetrical configuration of the drone exhaust systems. All exhaust ports were either on the right side or on the bottom of the nacelle. The missiles apparently lost lock as the source of IR energy disappeared behind the drone fuselage when the aspect angle changed.

(U) Missiles 505, 717, and 719 were fired on 2 November 1961. Because of the attenuation of IR intensity in the two earlier firings, the target course was reversed so that these rounds would attack the right side. All three missiles successfully acquired the IR signal at launch and appeared to guide throughout flight. Missiles 505 and 719 missed their targets by 100 feet. The camera coverage for Missile 717 was not assessable, but the miss distance visually appeared to be close. Missile 505 did not self-destruct

²⁶ (1) *Ibid.* (2) TT ORDXR-C-255-61, Cdr, ARGMA, to CofOrd, 22 Nov 61. Hist Div File. (3) ARGMA Hist Sum, 1 Jul - 11 Dec 61, pp. 66-68.

as planned.²⁷

(U) The costs incurred for the accelerated firing program amounted to \$571,612. In addition to the drain on funds required to complete the planned development program, the diversion of contractor engineering effort introduced a further delay of 4 to 6 weeks in the program schedule.²⁸

(U) The difficulty encountered by the seeker in acquiring a target without flare augmentation led to the conclusion that solutions to the primary technical problems were more complex than anticipated. An analysis of the accelerated firings showed that significant progress had been made toward solving three of the four problem areas. The fourth—background rejection—had received minimum effort, partly because of a lack of funds and partly because of the acceptance of the degradation caused thereby. However, a reappraisal of the system's operational capability against low radiating targets, even under light or moderate background conditions, indicated a much more severe degradation than expected.

(U) An investigation of the background interference from reflected solar energy and other extraneous sources revealed that most of the interference that tended to limit REDEYE effectiveness came from solar energy reflected from clouds and terrain. A potential target, although detected by the operator, might not be acquired by the seeker because of the overriding intensity of the background near or surrounding the target. The degree of degradation was dependent upon the target radiant intensity as compared to the magnitude of the background. A study of the radiation characteristics of REDEYE targets disclosed that the average

²⁷ *Ibid.*, pp. 68-69.

²⁸ TT ORD XR-RHA-792, CG, AOMC, to CofOrd, 17 Nov 61. Hist Div File.

radiant intensities were lower than originally anticipated, owing to the target types and aspect angles of engagement.

(U) As a possible solution to the background problem, General Dynamics proposed the use of a dual-band reticle in conjunction with a thermoelectric cooled lead sulphide (PbS) cell. With this system, an improvement of 220 percent was expected on small targets under the severe conditions of bright clouds, essentially restoring the capability to the level attainable with the existing system with clear sky background. For larger targets, about the same order of improvement would be realized.²⁹

Revision of the Program Schedule

(U) Concurrently with the foregoing system reviews and evaluations, AOMC received an increasing number of inquiries from both the user and higher staff levels, regarding the assurance level of achieving a successful system demonstration. In view of the results of the accelerated test firings and the magnitude of the unsolved technical problems, the Command concluded that the current level and direction of effort was not adequate to provide for the assurance level considered mandatory for success. In one of his first official acts as the new Deputy Commanding General for Guided Missiles, BG John G. Zierdt, on 21 December 1961,^{*} prepared a revised program schedule which recommended a general reorientation of the development effort, a substantial increase in FY 1962 RDTE funds, deferment of REDEYE procurement until FY 1963, and a 12-month extension in the Ordnance Readiness Date.

* As stated in the chapter dealing with organization and management, ARGMA was abolished on 11 December 1961 and its functions merged with AOMC Headquarters. See above, p. 24.

²⁹ Rept, REDEYE Performance Against Background, atchd as Incl 3 to Ltr, DCG/GM, AOMC, to CofOrd, 21 Dec 61, subj: Revised REDEYE Program. Hist Div File.

(U) The need for a redirection of the development effort stemmed from two basic factors: a lack of adequate funds to fulfill the reduced REDEYE specifications within the timeframe desired by the user, and several complex technical problems, the solutions to which were yet to be proved. The revised schedule included parallel solutions for increased assurance of successful development, as opposed to the non-parallel or singular series solution previously pursued primarily because of dollar limitations. The latter approach had been dictated largely by the bounds established through oversimplification of the problems with the resulting austere budget. Moreover, programming before August 1961 had been influenced by attempting to meet deadlines based upon factors other than realistic engineering.

(U) Under the proposed schedule revision, an 80 percent level of assurance that the technical problems could be resolved was expected by April 1962, with a final determination to be made during the Design Release Review in July 1962. Aside from the four major problem areas requiring resolution through concentrated engineering, as opposed to design effort, the tactical prototype and engineering missiles would have to be updated to the final hardware configuration.* Since available FY 1962 RDTE funds (\$5,055,000) were not adequate to achieve these goals, emergency funds were requested in the amount of \$4,066,000, bringing the total requirement for the year to \$9,121,000. Funding support estimated for FY 1963 was \$3.6 million, including \$1,018,000 for the fabrication of service test hardware which was deleted from the FY 1962 program.

* As of December 1961, GD/P had fabricated, to sub-section level, 75 tactical prototype weapons for the system demonstration and preliminary user tests, and 50 engineering missiles for the engineering evaluation at WSMR. Five additional tactical prototype missiles would have to be fabricated to replace those used in the special DA-directed firings.

UNCLASSIFIED

~~CONFIDENTIAL~~

(S) In view of the modified R&D schedule, it was recommended that procurement of the REDEYE system and the 3-G-84 training device be postponed until FY 1963, and that the Ordnance Readiness Date be slipped by 12 months, to November 1964. Assuming positive progress in the solution to technical problems, it was considered advisable to effect an engineering release to industrial and initiate advance production engineering by 30 June 1962. This effort would be limited to 3 months (1 July - 30 September 1962), with a follow-on industrial engineering contract to be effective 1 October 1962, concurrently with hardware procurement. The delivery of industrial prototype missiles would begin in October 1963 (instead of April 1963) and tactical hardware deliveries would commence in May 1964 (instead of November 1963). The planned materiel procurement for the Army and Marine Corps, during the FY 1963-66 period, included 56,185 missiles, 123 sets of Type IV test equipment, and 1,031 3-G-84 training devices.³⁰

Implementation of the Reoriented Program

(U) With the approval of the reoriented program in January 1962, the commodity manager at AOMC was highly confident that General Dynamics would be able to meet the revised schedule. This confidence was bolstered by the results of laboratory and flight tests through 31 March 1962, which indicated that the major technical problems would be solved by the scheduled Design Release Review in July 1962. Programming actions were therefore taken, in March, to proceed with the planned 3-month preproduction engineering effort on 30 June.³¹ However, as past experience had shown, solutions to problems as complex as those confronting the REDEYE simply could not be scheduled with any degree of accuracy.

³⁰ Ltr, DCG/GM, AOMC, to CofOrd, 21 Dec 61, subj: Revised REDEYE Program, w incls. Hist Div File.

³¹ REDEYE Prog Repts, Jan - Mar 62. Hist Div File.

~~CONFIDENTIAL~~

UNCLASSIFIED

(U) In May and June 1962, considerable progress was made in laboratory tests of the design fixes, but the results of guided flight tests disclosed continuing component and launch difficulties. The new airframe configuration designed to correct the roll rate and maneuverability problem consisted of shrouded, cambered tails and fixed wings forward of the control surfaces. Flight tests of four LTV-1B rounds indicated that this configuration would provide acceptable roll rates and maneuverability; however, further refinement was needed to improve performance during the subsonic portion of flight. In the area of background rejection, two approaches were under study, one using electrically cooled indium arsenide and the other a gas (carbon dioxide) cooled PbS cell. The plan was to complete feasibility studies of these approaches by October 1962 and select one for complete development and integration into the system design at a later date. The need for drastic improvements in these and other areas was evident in the flight test of 11 GTV-2 rounds, none of which achieved a physical intercept.

(U) In May, the contractor fired four rounds at NOTS and three at San Clemente Island. Of the four NOTS firings, one missed the target by 6 feet, two by less than 35 feet, and one by more than 50 feet. The three at San Clemente Island all had large miss distances because of insufficient IR signal for effective guidance. These were followed, in June, by four more GTV-2 firings at NOTS. None of the first three rounds had an opportunity to hit or come close to the target, one of them experiencing a gyro failure at launch and the other two having excessive tip-off rates (launch difficulty). The fourth round exhibited normal performance to intercept, but missed its target by about 55 feet.³²

(U) In view of the continuing technical difficulties, the

³² REDEYE Prog Repts, May - Jun 62. Hist Div File.

UNCLASSIFIED

~~CONFIDENTIAL~~

Commanding General of AOMC, in early July 1962, cancelled contract negotiations for the advance production engineering program and revised the schedule accordingly. He extended the Design Release Review and interim design release from July to September, and scheduled the system demonstration for the week of 9 September 1962. Plans to execute engineering services and production contracts about 1 October 1962 with FY 1963 PEMA funds were not affected. The Ordnance Readiness Date of November 1964 was also unchanged, despite a 3-month extension in initial industrial prototype deliveries from October 1963 to January 1964. This delay was necessary because of the requirement for a 15-month engineering effort to design and fabricate special acceptance inspection equipment before the first production delivery.³³

Meanwhile, the DA General Staff, on 28 June 1962, renewed the LP classification for the REDEYE system for a 1-year period^{*} and type classified the AN/TSM-54 missile test set as LP. The procurement quantities approved for the first-year buy in FY 1963 consisted of 1,539 tactical missile units, including 340 industrial prototypes, and 42 test sets. Planned procurement during the FY 1964-66 period, under a Standard A classification, included 55,458 missile units and 48 test sets. The estimated unit costs for the missile system in quantity production were \$12,379 for the first-year buy (FY 1963), \$4,273 for FY 1964, \$3,060 for FY 1965, and \$2,627 for FY 1966.³⁴

* The weapon system was originally classified as LP for a 2-year period by OTCM 37512, 18 August 1960. See p. 78.

³³(1) TT ORDXM-XGM-69, CG, AOMC, to CofOrd, 3 Jul 62. (2) Ltr, same to same, 17 Jul 62, subj: REDEYE APE Contr. Both in Hist Div File.

³⁴OTCM 38086, 28 Jun 62. RSIC.

~~CONFIDENTIAL~~

UNCLASSIFIED

~~UNCLASSIFIED~~

~~CONFIDENTIAL~~

Deferment of FY 1963 Procurement

(U) At the time of the foregoing action, there was reason to believe that the REDEYE system planned for production release in October 1962 would meet all of the original MC's except in those areas waived by the users and concurred in by the DA General Staff.³⁵ Three months later, however, a successful system demonstration still had not been achieved. Following a review of the development program, on 1 October 1962, the Director of Defense Research & Engineering (DDRE) Ad Hoc Group on REDEYE concluded that the weapon system was technically feasible, but the magnitude of the task had been grossly underestimated by both the Army and the contractor. While not questioning the tactical utility of, or requirement for the system, the members of the group agreed that the weapon was not suitable for release to production, principally because of insufficient guidance accuracy and the large background IR noise compared to the IR signal. They therefore recommended that the development effort be concentrated on a system with effective performance in these areas, and that a competitive R&D program be initiated immediately on an advanced system with superior performance over that expected for the basic REDEYE. The advanced system, they predicted, would probably be from 2 to 3 years behind the interim system.³⁶

(S) During a meeting held in Washington on 19 October 1962, LTC R. C. Daly of DCSLOG announced that the Defense Department had concurred in the conclusions and recommendations of the DDRE Ad Hoc Group and had deferred the entire FY 1963 procurement

³⁵ See above, pp. 84-87.

³⁶ Sum of CRD/C MFR dtd 12 Oct 62, subj: Rept of Mtgs DDRE Ad Hoc Gp on REDEYE, atchd as incl to DF, C&DP to REDEYE Cmdty Ofc, *et al.*, 24 Oct 62, subj: DA/AMC Staff Review of REDEYE, AMCP. Hist Div File.

~~CONFIDENTIAL~~

UNCLASSIFIED

UNCLASSIFIED

~~CONFIDENTIAL~~

program. He reiterated that the REDEYE system would not be approved for production release until there was a successful system demonstration, which had been rescheduled for April 1963. Even if the system demonstration were successful, the earliest that the procurement program could be released would be in June 1963. It was therefore decided to slip the initial FY 1963 buy to FY 1964. Because of the indicated follow-on of an improved or second generation REDEYE,^{*} production build-up on the REDEYE I would be to a minimum sustaining rate only (about 1,000 per month). The REDEYE II was expected to be ready for procurement by FY 1967. The planned procurement of the REDEYE I to meet Army requirements during the FY 1964-66 period totaled 18,520 units (735 in 1964; 8,185 in 1965; 9,600 in 1966). The REDEYE II would then take over, and quantities to meet the Army inventory objective would be programmed. Activation of the first 25 REDEYE teams was scheduled for 1965.³⁷

(U) The reoriented development program, submitted by the REDEYE Commodity Manager in late November 1962, was designed to give maximum assurance of providing a basic weapon system meeting all of the modified MC's, to include a background rejection capability consistent with the current state of the art. Primary attention would be focused on improvements in aerodynamic control, maneuverability, signal processing, optics, and background rejection. As an added measure of assurance, alternate approaches in the latter three areas would be investigated by the Hughes Aircraft Company as a major subcontractor to General Dynamics.

* To distinguish between the basic and improved systems, the former was referred to as the REDEYE I and the latter as the REDEYE II. The REDEYE II later became known as the STINGER.

³⁷ REDEYE-Detailed Data for AMCP Preparation, 23 Oct 62, atchd as incl to DF, C&DP to REDEYE Cmdty Ofc, *et al.*, 24 Oct 62, subj: DA/AMC Staff Review of REDEYE, AMCP. Hist Div File.

~~CONFIDENTIAL~~

UNCLASSIFIED

The best engineering estimates placed completion of the development program about 24 months from 1 February 1963, dependent largely upon progress in the area of background rejection. To maintain the level of effort necessary to meet the revised development schedule, additional FY 1963 RDTE funding of \$9.09 million would be needed, bringing the total requirement for the year to \$12.69 million.³⁸ The actual RDTE funding for FY 1962 amounted to \$8,828,000, some \$293,000 short of the registered requirement for \$9,121,000. This brought the total RDTE cost through 1962 to \$29,527,000, about \$8 million of which was furnished by the Marine Corps.³⁹ In addition to the requirement for \$12.69 million in FY 1963 RDTE funds, it was estimated that \$18,809,000 would be needed to complete development of the weapon system (\$14,433,000 in FY 1964 and \$4,376,000 in FY 1965), plus \$2.2 million for the training device.⁴⁰ These funding requirements brought the total projected development cost to \$63,226,000, in contrast to the original estimate of \$23,955,000.

(U) The industrial schedule evolved from the revised development program called for an interim production release in June 1963; initiation of a preproduction engineering planning study in June 1963; initial hardware procurement in October 1963; and a 15-month production leadtime. The hardware to be delivered under this program would have the modified MC's and initial deliveries (through about the second-year buy) would have limited background rejection. However, when developed, a full background rejection

³⁸ Ltr, REDEYE Cmdty Mgr to CG, AMC, 30 Nov 62, subj: Revised REDEYE Dev Program. Hist Div File.

³⁹ ADSIMO Rept, REDEYE Wpn Sys R&D Funding, Feb 73. Hist Div File.

⁴⁰ (1) R&D Anal for REDEYE Program, atchd as incl to SS AMSMI-R-21, R&D Dir to REDEYE Cmdty Mgr, 14 Feb 63, subj: R&D Anal - REDEYE. (2) Ltr, REDEYE Cmdty Mgr to CG, AMC, 30 Nov 62, subj: Revised REDEYE Dev Program. Both in Hist Div File.

capability would be incorporated. This would permit early delivery of the REDEYE and at the same time minimize the quantity with limited capability. A retrofit program for the initial industrial rounds was not recommended. Instead, those rounds remaining would be recycled and used for training purposes. Under the revised industrial program, the first REDEYE team, equipped with a basic load of 12 rounds and backup of 6 rounds, was to be activated by July 1965.⁴¹

(U) Representatives of the REDEYE Commodity Office presented the revised program to the Assistant Secretary of the Army, R&D, and the Chief of R&D, on 7 December 1962. During the presentation, members of both DA staff elements approved the proposed program and stated that the requested \$9.09 million in additional FY 1963 RDTE funds would be provided to finance the effort from 1 February 1963 through 30 September 1963. They also agreed that the REDEYE weapon system had the highest priority within the air defense area.⁴²

Transition from R&D to Production

(U) Except for the June 1963 preproduction engineering study, which was rejected by the Defense Department,⁴³ and a delay of some 3 months in initial hardware procurement,⁴⁴ General Dynamics met most of the key target dates of the revised program. The contractor completed the Phase A flight tests in December 1963⁴⁵ and the basic REDEYE system with modified MC's entered the

⁴¹*Ibid.*

⁴²TT AMSMI-XGM-71, CG, MICOM, to CG, AMC, 8 Mar 63. Hist Div File.

⁴³MICOM Hist Sum, FY 1963, p. 153.

⁴⁴MICOM Hist Sum, FY 1964, p. 67.

⁴⁵REDEYE PM₂P, 30 Jun 67, p. 32. Hist Div File.

industrial stage early in 1964. Thereafter, design changes in the weapon system were made by engineering change order under the product improvement program.

FY 1963-64 Development Costs

(U) During the December 1962 presentation, the DA Staff members had assured the REDEYE Commodity Manager that the \$9,090,000 in additional FY 1963 RDTE funds would be provided to fund the program from February through September 1963, and directed that this effort be under a cost-plus-incentive-fee (CPIF), instead of cost-plus-fixed-fee, contract. However, their failure to provide funds on a timely basis threatened to undermine the intent of the incentive fee contract. On 25 January 1963, just 6 days before funds under the existing contract ran out, MICOM received \$750,000 from the Marine Corps, but the funds promised by the Army still had not arrived on 8 March, 91 days after the presentation. With the Marine Corps money and the unspent project funds available at MICOM, the commodity manager negotiated a letter order contract for \$1.6 million, enough to carry the program through 15 March 1963 (40 days).⁴⁶ The first increment of \$1 million in Army funds came on 13 March, followed by \$3 million later in the month, all of which was used to extend the performance period under the letter order contract.⁴⁷ Subsequent incremental funding increased the total 1963 RDTE program to \$12,951,000, including the \$750,000 Marine Corps contribution.⁴⁸

(U) The RDTE funding program reached a peak of \$16,020,000 in

⁴⁶TT AMSMI-XGM-71, CG, MICOM, to CG, AMC, 8 Mar 63. Hist Div File.

⁴⁷SS AMSMI-XGM-7, REDEYE Cmdty Ofc, 25 Mar 63, subj: REDEYE Contr, w incl: TT AMCMI-XGM-89, CG, MICOM, to CG, AMC, 26 Mar 63. Hist Div File.

⁴⁸ADSIMO Rept, REDEYE Wpn Sys R&D Funding, 20 Feb 73. Hist Div File.

FY 1964, an increase of \$1,587,000 over the requirement projected in February 1963.⁴⁹

Improvement in System Performance and Reliability

(U) Despite the unsettling influence of piecemeal funding in FY 1963, General Dynamics made notable progress in solving the major technical problems (roll rate, maneuverability, cell sensitivity, launcher tip-off rate, and background rejection). All of the problems were solved to some extent, but background rejection remained the most difficult of solution. Canted jet vanes in the sustainer motor nozzle with a tail shroud and cambered tails appeared to alleviate the roll rate problem, and the forward fixed-wing design improved maneuverability. To reduce the tip-off rate, the contractor designed and tested a zero-length launcher. After four flight tests, in March 1963, the best features were adopted for the new smooth-bore launcher. Improved detector cells and cooling techniques, extensive reticle design, and improved circuitry were instrumental in reducing the effects of problems in the areas of cell sensitivity and background rejection. Further design refinement was necessary, however, before incorporating these corrections into the tactical system.

(U) During FY 1963, General Dynamics fired 75 REDEYE missiles, 23 of which were fully guided rounds. Four of the GTV's scored direct hits on the target drones. The first of these occurred in firing Missile 292, on 14 December 1962, against a 275-knot QF-9F drone flying at an altitude of 1,025 feet. The other three target hits took place during the first 6 months of 1963—one against a PB4Y2K target and two against KD2R5 drones.⁵⁰

⁴⁹ (1) *Ibid.* (2) *Also see* above, p. 114.

⁵⁰ (1) MICOM Hist Sum, FY 1963, pp. 153-54. (2) MICOM Rept 4M5N36, Jan-Mar 63, subj: Reliability Rept - Scorekeeping: Plots of Success/Failure of MsIs in Sys Tests, pp. 16-17. Hist Div File.

(U) During the monthly project review held at MICOM on 30 July 1963, General Dynamics reported that the development program was on schedule. Nevertheless, the REDEYE Commodity Manager decided, with DA approval, to delay the release of the initial industrial contract until January 1964. This delay of 3 months would allow additional time for work on system reliability, specifically the REDEYE's ability to function in a user environment. Previously, primary emphasis had been focused on system performance.⁵¹

Release for Limited Production

(U) By early October 1963, the REDEYE program had reached the point where a firm decision had to be made either to go into production or to eliminate the entire system.⁵² A review of the program status at that time disclosed that the progress made toward achieving the objectives of the reoriented development effort had been highly satisfactory. Particularly gratifying was the phenomenally successful demonstration of the new gyro/optics, control, and signal processing systems in a series of 13 flight tests. These rounds were flown against various targets flying at speeds of 75 to 375 knots, at altitudes of 410 to 4,500 feet, and at ranges of 1,100 to 2,900 meters. Eleven of the 13 missiles physically impacted the target, and the other two missed the IR centroid of target radiation by about 12 inches. Although the performance boundaries had not been extensively explored, the demonstrated system performance, combined with computer studies, indicated that the ultimate capability of the weapon system would be in accordance with the modified MC's.

(U) The background rejection capability had been improved by

⁵¹ MICOM Hist Sum, FY 1964, p. 67.

⁵² Journal Entry, CG, MICOM, 4 Oct 63. Hist Div File.

UNCLASSIFIED

~~CONFIDENTIAL~~

a factor of two by electrically cooling the lead sulfide (PbS) cell, and effort was continuing in two areas to achieve the optimum capability at the earliest possible date. One of these was the electrically cooled indium arsenide cell. The other was a backup seeker, with a cryogenically cooled PbS cell, being developed by the Hughes Aircraft Company.

(U) After considering the foregoing progress report, MICOM concluded that the REDEYE essentially met the modified MC's except for weight. Although the background rejection capability was not optimum, the missile was considered to be tactically useful in its current configuration. In view of this and the urgent need for the REDEYE to fill a void in the arsenal of air defense weapons, the Commanding General of MICOM recommended a continuation of the RDTE program, to include the background rejection effort at Hughes Aircraft and General Dynamics; a comprehensive reliability program in FY 1964; continued design refinement to improve performance and producibility; and R&D support of the industrial program. With the full understanding that there was a calculated risk involved, in that performance boundaries had not been fully explored and background rejection was limited, he recommended that the REDEYE system be released for limited production. The quantities initially procured, he suggested, should be limited to the minimum required to fulfill early needs of non-tactical claimants and the urgent requirements of tactical units.⁵³

In April 1963, AMC Headquarters had recommended that the REDEYE be continued in the LP category for a period of 2 years, and that the following quantities be authorized for procurement:

⁵³Ltr, CG, MICOM, to CG, AMC, 11 Oct 63, subj: REDEYE Program, atchd as incl to SS AMSMI-XGM-5, REDEYE Cmdty Ofc, 10 Oct 63, subj: same. Hist Div File.

~~CONFIDENTIAL~~

UNCLASSIFIED

UNCLASSIFIED

~~CONFIDENTIAL~~

<u>FY</u>	<u>System Tactical Units</u>			<u>Test Sets</u>		
	<u>Army</u>	<u>USMC</u>	<u>Total</u>	<u>Army</u>	<u>USMC</u>	<u>Total</u>
1964	305	350	655	17	9	26
1965	5,565	2,674	8,239	56	0	56

Missile procurement following a Standard A classification was estimated at 42,306 during the FY 1966-68 period, making a total planned production of 51,200 units (44,396 Army; 6,804 USMC).⁵⁴ The proposed first-year buy of 655 missiles in FY 1964 represented a decrease of 874 from the quantity contained in the cancelled FY 1963 program.⁵⁵ The DA Staff, in December 1963, reduced the first-year buy even further and refused to extend the LP classification beyond FY 1964 until firm quantities had been established and funds budgeted. Approved for FY 1964 procurement were 294 system tactical units (139 Army; 155 USMC) and 13 test sets (10 Army; 3 USMC).⁵⁶

⁵⁴ Ltr, CG, AMC, to CRD, DA, 3 Apr 63, subj: Req for Extension of LP TCLAS - REDEYE. Recorded in AMCTCM 1912, 13 Feb 64. RSIC.

⁵⁵ See above, p. 111.

⁵⁶ 1st Ind, CRD, DA, to CG, AMC, 12 Dec 63, on Ltr, CG, AMC, to CRD, DA, 3 Apr 63, subj: Req for Extension of LP TCLAS - REDEYE. Both recorded in AMCTCM 1912, 13 Feb 64. RSIC.

~~CONFIDENTIAL~~

UNCLASSIFIED

CHAPTER VI

INDUSTRIAL AND PRODUCT IMPROVEMENT PROGRAMS (U)

(U) Under the industrial program approved by the Chief of Research & Development in December 1963, the Army Missile Command planned to complete engineering and service tests during the production of Block I and II systems in 1964-65 and, hopefully, to obtain approval for classification of the system as Standard A for the first quantity procurement of the final Block III system in FY 1966. All major changes were planned for the Block III weapon, in order to minimize the effect on production, to stabilize configuration management, and to reduce the number of different configurations to be supported in the field. However, this plan, like so many others before it, turned out to be overly optimistic. Because of continuing reliability and production problems, the weapon system remained in the LP category until December 1968, and the number of engineering design changes far exceeded that of a normal product improvement program.

(U) As a result of the urgent need for the **REDEYE** and the decision to place the weapon in production before the tactical design was established at an optimum level of reliability, more than \$42 million in development and engineering costs were incurred after initiation of the production phase early in 1964. The system design was in a constant state of change throughout the FY 1964-67 period. Indeed, the magnitude of design changes still being introduced in FY 1967 led to the deferment of the production buy for that year until the rate of changes could be reduced, the design firmed, and the system's reliability, producibility, and performance could be demonstrated by confirmatory tests of production model missiles. As a result, delivery

UNCLASSIFIED

~~**CONFIDENTIAL**~~

schedules and deployment dates were not met. Moreover, cost estimates for the proposed design changes were extremely optimistic, creating a serious problem in the area of contract cost management; and planned savings from second source and competitive procurement did not materialize because of a reduction in REDEYE requirements.¹

Production Base Line

(C) Because of slippages in the development schedule and fluctuations in requirements for the REDEYE, the project plan for establishing a production base line underwent several revisions. The original estimate of REDEYE requirements for the Army and other customers totaled 40,500 units, which were to be procured during the FY 1959-61 period. This projection was reduced, in November 1959, to 37,590 units during the FY 1961-64 period. The revised plan of June 1962 raised the production quantity to 56,997 during the FY 1963-66 period, with a planned first-year buy of 1,539 missiles. The estimated production quantity was then reduced, in April 1963, to 51,200 units during the FY 1964-68 period, with a planned first-year buy of 655. The DA Staff, in December 1963, reduced the FY 1964 buy from 655 to 294.²

(U) The production base project request of October 1962 was updated in December 1963 to reflect the latest procurement plans. The request for \$1,626,000 covered the cost of rearranging the existing Navy-owned contractor-operated facilities at Pomona, California, and the acquisition of additional facilities and

¹(1) USAAA Rept No. SO 67-12, REDEYE ADGM Sys, Sec B-1. Atchd as incl to Ltr, CG, MICOM, to TAG, DA, 29 Sep 67, subj: USAAA Rept on the REDEYE ADGM Sys. Hist Div File. (2) 1st Ind, ACSFOR, DA, to CG, AMC, 18 Dec 68, on Ltr, CG, AMC, to ACSFOR, 18 Oct 68, subj: Req for Apprl, STD-A. Atchd to AMCTCM 6791, 9 Apr 69, subj: Recording DA Apprl of TCLAS fr LP to Std A of GM Sys, Intercept-Aerial: M41. RSIC.

²See above, pp. 49, 53, 111, 119-20.

~~**CONFIDENTIAL**~~

UNCLASSIFIED

~~UNCLASSIFIED~~
~~CONFIDENTIAL~~

equipment to establish the capacity necessary to meet early industrial procurement rates. An additional \$941,000 would be required in FY 1965 to attain maximum rates for quantity production. The additional facilities consisted of a larger clean room area, general machine tools, and assembly and shop test equipment.³

☞ The updated project request, submitted in March 1964, established a need for a maximum production capacity of 2,500 per month on a 1-8-5 shift basis, to meet the combined U. S. and MAP* requirements. General Dynamics declined a proposition to procure the needed additional facilities with corporate funds, because of the small quantity of missiles committed to production in FY 1964.⁴ The Army Materiel Plan of April 1964 provided for the production of 43,151 REDEYE systems for U. S. and MAP claimants, including a first-year (FY 1964) buy of 301 units. (Production requirements for the REDEYE were later reduced by 11,883 units, from 43,151 to 31,268.)

Block I (XM-41) System - FY 1964

☞ The industrial phase of the REDEYE program commenced early in 1964, using FY 1963 PEMA funds. General Dynamics began the 90-day preproduction planning study on 16 January 1964, under a \$384,934 contract (AMC-372). Industrial engineering services and production contracts for the first-year buy were awarded to General Dynamics on 10 April 1964. Contract AMC-417, for \$4,981,648, covered a 6-month industrial engineering services

* Military Assistance Program.

³Ltr, DCG/ADS to CG, AMC, 16 Dec 63, subj: Resubmission of PEMA Proj AMCMS Code 4910.1.82044 (REDEYE), w incl. Hist Div File.

⁴Ltr, DCG/ADS to CG, AMC, 12 Mar 64, subj: Resubmission of PEMA Proj AMCMS Code 4910.1.82044 (REDEYE). Hist Div File.

~~CONFIDENTIAL~~

UNCLASSIFIED

~~UNCLASSIFIED~~

~~CONFIDENTIAL~~

effort. Contract AMC-412, in the amount of \$8,240,710, provided for the production and delivery of 301 Block I (XM-41) REDEYE systems over a 6-month period, beginning in July 1965.⁵ The cost of the first-year buy—including Government-furnished equipment, such as warheads, fuzes, and batteries, and in-house and indirect costs—totaled \$25,107,085.56 (\$24,608,319.56 for missiles and \$498,766.00 for 13 test sets). The Marine Corps supplied \$12,765,439.58 of the total PEMA funds obligated.⁶

(U) In February 1964, DCSLOG expressed concern about the average unit cost of the REDEYE, which then stood at \$6,250. The Commanding General of MICOM was confident, however, that this cost would taper off with competitive procurements in FY 1967-68, the predicted unit costs for those years being \$5,200 and \$4,500, respectively.⁷ For the first 2 years of the industrial program, it was determined that competition would not be economical because of the small quantities involved, the lack of adequate documentation, and the large investment in facilities and tooling.⁸

(U) The Block I XM-41 weapon system consisted of the XFIM 43A guided missile, the XM-147 launcher, and the XM-547 shipping and storage container. The major components of the 43A missile

⁵(1) REDEYE Chronology. (2) 1st Ind, CG, MICOM, to CG, AMC, 13 Mar 64, on Ltr, CO, LAOD, thru CG, MICOM, to CG, AMC, 10 Mar 64, subj: Req for Apprl of Awd [for FY 64 REDEYE Indus Engrg Svcs]. (3) 1st Ind, CG, MICOM, to CG, AMC, 13 Mar 64, on Ltr, CO, LAOD, thru CG, MICOM, to CG, AMC, 10 Mar 64, subj: Req for Apprl of Awd [for FY 64 REDEYE Indus Hardware]. All in Hist Div File.

⁶Rept, PEMA REDEYE Msl Sys Maj Items, 27 Jun 73, Budget Div, Compt. Hist Div File.

⁷(1) Ltr, DCSLOG, DA, to CG, AMC, 24 Feb 64, subj: REDEYE. (2) Ltr, CG, MICOM, to CG, AMC, 10 Mar 64, subj: same. Both in Hist Div File.

⁸USAAA Rept No. SO 67-12, REDEYE ADGM Sys, Sec B-1. Atchd as incl to Ltr, CG, MICOM, to TAG, DA, 29 Sep 67, subj: USAAA Rept on the REDEYE ADGM Sys. Hist Div File.

~~CONFIDENTIAL~~

UNCLASSIFIED

included the Mod 60 seeker head with a thermoelectrically cooled PbS detector cell, the XM-110 dual purpose rocket motor, and the XM-137 warhead section with the XM-45 warhead and XM-804 fuze. The 18-lb. missile was 2.75 inches in diameter and 47.5 inches long from the tip of its seeker dome to the end of the motor exhaust shroud.

(U) The XM-147 launcher was made up of the launching tube, gripstock, and telescopic sight assembly with a target acquisition indicator. It weighed 11 pounds and was 49.7 inches long and 3.61 inches in diameter. The missile was sealed in its launcher at the factory and the air in the launcher was replaced with inert gas. The launcher thus served not only to acquire and track the target, but also to protect the missile until it was launched.

(U) The XM-547 shipping and storage container, known as the TRIPAC, was a reusable, noncollapsible case capable of accommodating three complete missile-launcher assemblies and nine launcher batteries and coolant units. This plastic, polyurethane-lined container weighed 68 pounds when empty and 164 pounds when loaded. It was about 55 inches long, 21 inches wide, and 19.5 inches high.

(U) The AN/TSM-54 guided missile test set was a go-no-go testing device for use by Ordnance ammunition supply points and depots to test the functioning of the tactical missile system before issue and storage. It was also used to test the REDEYE training device. The 217-lb. test set was a self-contained, single unit about 54 inches long, 20 inches high, and 28 inches deep.⁹

(U) Delivery of the 301 Block I systems began in September

⁹(1) OTCM 38086, 28 Jun 62. (2) AMCTCM's 3876, 18 Nov 65; 5004, 5 Jan 67. (3) AMC TIR 21.1.6.1(2), Dec 66, pp. 3, 10, 12. All in RSIC.

1965 and was completed in May 1966. Most of these weapons were expended in engineering and service tests.¹⁰

(U) General Dynamics initiated the FY 1964 product improvement effort in October 1963 under Contract AMC-315,¹¹ which replaced the original R&D contract (ORD-1202). As stated earlier, the RDTE funding program for FY 1964 totaled \$16,020,000.¹² Primary effort was focused on the background rejection problem and design refinements to improve system performance, producibility, and reliability. The indium arsenide detector effort was terminated in November 1963, because the cell assembly (detector and immersion lens) was unable to withstand the necessary temperature excursions. This was followed, in April 1964, by cancellation of the Hughes Aircraft backup seeker program, because of the similarity between the Hughes and General Dynamics designs and the fact that General Dynamics' Mod 60A gas cooled PbS seeker head was nearer completion.

(U) During FY 1964, the contractor test fired 28 GTV rounds—14 with the original uncooled PbS conical scan seeker, 12 with the Mod 60 (Block I) electrically cooled PbS head, and 2 with the new Mod 60A gas cooled head. Of the 14 rounds with the uncooled seeker, 10 made direct hits, 1 had a 1-foot miss distance, and 3 were considered no test. Seven of the 12 rounds with the Mod 60 seeker head scored direct hits, while 3 hit within 5 feet of the target and 2 were scored no test. Two of these rounds were of the dual-band reticle configuration. The first round with a Mod 60A seeker head was test fired on 12 June 1964 and scored a direct hit

¹⁰(1) REDEYE Chronology. (2) Ltr, DCG/ADS, MICOM, thru CG, AMC, to Dir of Mat Acq, Ofc, ASA(I&L), 16 Feb 68, subj: Req for Apprl of D&F, REDEYE Wpn Sys, & incl thereto. Hist Div File.

¹¹SS AMSMI-I-43-64, 28 Feb 64, subj: Req for Apprl of Awd of a CPIF Contr for FY 64 REDEYE R&D Effort. Hist Div File.

¹²See above, pp. 116-17.

on the drone. The other round, also fired in June, was erroneously launched before achieving acquisition.¹³ The Mod 60A gas cooled seeker, the last major component to complete engineering design, was later released for incorporation in the Block II production missile.

(U) Although background rejection remained a problem with the system, cryogenic cooling of the detector and longer wavelength response were expected to improve performance.¹⁴ Another problem of growing concern was the lack of an IFF capability in the system. As of June 1964, there was no lightweight IFF system compatible with the REDEYE and a definitive requirement for the development of one was yet to be established.¹⁵

Block II (XM-41E1) System - FY 1965

(U) In FY 1965, the REDEYE industrial program experienced serious funding difficulties, chiefly because of growing Congressional disenchantment with the weapon system. In April 1964, following the FY 1965 budget hearings, Congress deleted the planned REDEYE PEMA program from the Department of Defense (DOD) budget. In an effort to get the program reinstated, DA Staff officials, on 25 January 1965, provided the Senate Appropriations Subcommittee with information on the REDEYE reprogramming request and the urgent need for the weapon system to fill a critical gap in forward area air defense. The reaction of the committee was one of continued reluctance to approve the program on the grounds that the Army had been carrying the project for some 5 years and

¹³ MICOM Hist Sum, FY 1964, p. 69.

¹⁴ *Ibid.*, p. 70.

¹⁵ SS AMSMI-XGM-2-64, REDEYE Cmdty Mgr, 22 Jan 64, subj: IFF Sys for REDEYE, w incl, Ltr, DCG/ADS to CG, CDC, 23 Jan 64, subj: REDEYE IFF. Hist Div File (2) *Also see* above, p. 87.

UNCLASSIFIED

~~CONFIDENTIAL~~

had poured much time and money into it without realizing any big improvements in system performance. Moreover, the committee expressed doubt as to the need for a sophisticated weapon such as the REDEYE, when aircraft were then being downed with rifles in Southeast Asia. The Army's briefing on the capabilities and effectiveness of the REDEYE did much to dispel the stated objections, but the committee still was not fully satisfied that more money should be invested in the system. After other paper exercises and presentations to Congressional committees, a reduced PEMA program was approved in February 1965.¹⁶

(S) Coincident with Congressional approval of the FY 1965 PEMA program, on 19 February 1965, DA extended the LP classification of the REDEYE system and AN/TSM-54 test set for 2 years, and authorized the procurement of 1,614 tactical Block II missile units at an estimated cost of \$31.8 million. The authorized procurement program also included 49 test sets and 140 Block II missiles for service tests.¹⁷ The 140 test missiles were procured with RDTE funds, but were covered in the FY 1965 PEMA D&F.¹⁸

(S) In April 1965, a CPIF contract (AMC-644) for \$16.3 million was signed with General Dynamics for production of 1,754 Block II missiles and 40 test sets. The delivery of missile hardware was scheduled to begin in March 1966 and continue over a 9-month period. Another CPIF contract with General Dynamics,

¹⁶ (1) Principal Item Status Sheet - REDEYE PM, 29 Dec 64. RHA Bx 13-230. (2) TT AMCPM-RE-39-65, CG, MICOM, to CG, AMC, 29 Jan 65. (3) Hist Rept, REDEYE PM, FY 1965, p. 1. Both in Hist Div File.

¹⁷ (1) *Ibid.* (2) 1st Ind, OCRD, DA, to CG, AMC, 19 Feb 65, on Ltr, CG, AMC, to OCRD, 28 Oct 64, subj: Req for Extension of LP TCLAS - REDEYE. Recorded in AMCTCM 3288, 20 May 65. RSIC.

¹⁸ TT AMCPM-RE-57, CG, MICOM, to CG, AMC, 10 Jun 64. Hist Div File.

~~CONFIDENTIAL~~

UNCLASSIFIED

UNCLASSIFIED

~~CONFIDENTIAL~~

for \$10.5 million, extended engineering services and support through September 1965.¹⁹ The final cost of the FY 1965 industrial program (including Government-furnished equipment and in-house and indirect costs) came to \$36,081,259.84, of which the Marine Corps supplied \$10,710,234.05.²⁰

(U) The tactical Block II XM-41E1 weapon system incorporated a number of design changes to improve performance and producibility. It consisted of the XFIM 43B guided missile, the XM-147E1 launcher, and the XM-547E1 shipping and storage container. Modified components in the 43B missile included the Mod 60A gas cooled detector cell (instead of the electrically cooled cell) and the XM-137E1 warhead section with the XM-45E1 warhead and XM-804E1 fuze. Designed for firing missiles in the XM-41E1 and XM-44E1 (practice) systems, the smooth bore XM-147E1 launcher differed from the XM-147 in that it had sealed components and the impulse generator was changed and relocated. It used the XM-59 optical sight, a sealed unit magnification, wide field telescope. Among changes in the TRIPAK XM-547E1 shipping and storage container were reversed sealing rims and different mounting pads. None of the major items peculiar to the XM-41E1 weapon system was interchangeable with like items in the basic XM-41 system.²¹

(U) The product improvement effort in FY 1965 was focused on engineering design changes for incorporation in the final Block III

¹⁹ (1) Hist Rept, REDEYE PM, FY 1965, pp. 1-2. (2) The Block II systems actually produced under Contract AMC-644 totaled 1,743. Missile production was stopped with delivery of the last 33 units in May 1967, so that test equipment could be converted to Block III. Forty-nine test sets were produced under the contract—6 AN/TSM-54 (Block II) and 43 AN/TSM-82 (Block III). P&PD Rept, Perf of Selected Contrs, May 67 & Sep 67. Hist Div File.

²⁰ Rept, PEMA REDEYE Msl Sys Maj Items, 27 Jun 73, Budget Div, Compt. Hist Div File.

²¹ AMCTCM's 3876, 18 Nov 65; 5004, 5 Jan 67. RSIC.

~~CONFIDENTIAL~~

UNCLASSIFIED

(XM-41E2) weapon system, redesign of the Block II AN/TSM-54 test set to make it compatible with the Block III missile configuration, and flight tests to evaluate guidance accuracy and reliability. Most of the component changes for the Block III missile were aimed at improving maintainability and reducing production costs. Among these were a one-piece hermetically sealed seeker that could be repaired at depot level; a less expensive one-piece fuze-warhead assembly with a new fuze packaged in a small steel can; and the use of separable (threaded coupling) missile joints in place of bonded joints.

(U) From 1 July 1964 to 30 June 1965, General Dynamics fired 48 REDEYE missiles at NOTS—10 R&D rounds, 22 engineering guidance test vehicles (EGTV's), and 16 tactical prototypes. Of these, 15 were equipped with the Mod 60 electrically cooled PbS detector cell, which was being produced for the Block I (XFIM 43A) missile. The other 23 rounds used the Mod 60A gas cooled cell, which was released for the Block II (43B) production missile. Eleven Mod 60A and 4 Mod 60 missiles intercepted the IR source.

(U) Of the 10 R&D rounds—all equipped with the Mod 60A seeker—6 scored direct hits, 2 came within 6 feet of the IR source, and 2 were failures.

(U) Fifteen of the 22 EGTV's carried the Mod 60 seeker and 7 the Mod 60A. Four of the 15 Mod 60 rounds scored direct hits, 5 missed the IR source by 2 feet, 2 came within 6 feet, and 4 were failures. None of the seven Mod 60A rounds intercepted the IR source, but three came within 2 feet of it. Two of the other rounds had large misses, and two were failures.

(U) All 16 of the tactical prototype rounds carried the Mod 60A seeker and 2 of them had live warheads. Five of the missiles scored direct hits, three came within 6 feet of the IR source, and two within 10 feet. Five of the others had large misses, and

UNCLASSIFIED

~~CONFIDENTIAL~~

one was rated a failure.²²

(U) Except for minor development effort on training equipment, the engineering design phase of the basic REDEYE program was completed in November 1965 with FY 1965 funds,²³ a slippage of 4 years from the original schedule. The total RDTE obligations dropped from a peak of \$16,020,000 in FY 1964 to \$11,412,000 in FY 1965, the Marine Corps providing \$300,000 of the latter sum. This brought the total development cost to \$69,910,000 for the FY 1958-65 period, \$9,500,000 of which was supplied by the Marine Corps.²⁴

Block III (XM-41E2) System - FY 1966-68

FY 1966

Fiscal Year 1966 marked the first quantity procurement of the REDEYE system. The approved PEMA funds for the third-year buy included \$55.9 million in Army money plus a customer share of \$13.7 million. A fixed-price-incentive-fee (FPIF) contract (AMC-990), for \$41.1 million, was negotiated with General Dynamics in October 1965 for the production and delivery of 10,972* Block III weapons over a 12-month period beginning in October 1966. In November 1965, a CPIF contract for \$8.1 million was signed with General Dynamics for continued engineering services support through September 1966.²⁵ The actual cost of the FY 1966

* This represented a reduction of 434 from the 11,406 units approved for FY 1966 procurement in February 1965. (1st Ind, OCRD, DA, to CG, AMC, 19 Feb 65, on Ltr, CG, AMC, to OCRD, 28 Oct 64, subj: Req for Extension of LP TCLAS - REDEYE. Recorded in AMCTCM 3288, 20 May 65. RSIC.) The Block III weapons actually delivered under the contract totaled 10,985.

²² Hist Rept, REDEYE PM, FY 1965, pp. 3-4, 7. Hist Div File.

²³ REDEYE PM₂P, 31 Dec 66, p. 25. Hist Div File.

²⁴ ADSIMO Rept, REDEYE Wpn Sys R&D Funding, Feb 73. Hist Div File.

²⁵ Hist Rept, REDEYE PM, FY 1966, pp. 1-2. Hist Div File.

~~CONFIDENTIAL~~

UNCLASSIFIED

UNCLASSIFIED

~~CONFIDENTIAL~~

industrial program (including training equipment, Government-furnished equipment, and in-house and indirect costs) totaled \$71,647,233.41.²⁶

(U) Late in FY 1965, the REDEYE Project Manager completed plans for competitive breakout of the system. In arriving at the FY 1966 requirement and method of procurement, he determined that competition would be possible for a portion of FY 1966 and FY 1967 and the entire FY 1968 procurement of REDEYE hardware. Implementation of the plan was initiated in November 1965, with the award of a contract to Thermoplastics, Inc., for production of the TRIPAK shipping and storage containers which had been supplied by a subcontractor to General Dynamics. Although several other components were to have been procured on a competitive basis, this objective could not be attained in FY 1966 because of the configuration changes introduced in the transition from the Block II to the Block III system. These changes precluded the standardization of drawings and specifications suitable for competitive bidding and subsequent contract negotiation. As in the past, warheads/fuzes and batteries remained Government-furnished items contracted for and supplied by the Army Munitions Command and Electronics Command, respectively.²⁷

(U) The Block III cost reduction program led to a number of component changes in the weapon system released for quantity production. In addition to the changes mentioned earlier,²⁸ these included use of the open sight in place of the more expensive

²⁶ Rept, PEMA REDEYE Msl Sys Maj Items, 27 Jun 73, Budget Div, Compt. Hist Div File.

²⁷ (1) Hist Repts, REDEYE PM, FY 1965, p. 2; FY 1966, p. 3.
(2) USAAA Rept No. SO 67-12, REDEYE ADGM Sys, Sec B-1. Atchd as incl to Ltr, CG, MICOM, to TAG, DA, 29 Sep 67, subj: USAAA Rept on the REDEYE ADGM Sys. Hist Div File.

²⁸ See above, pp. 129-30.

~~CONFIDENTIAL~~

UNCLASSIFIED

telescopic sight, and integrated circuitry replacing discrete electronic components for reliability and high volume production. The complete XM-41E2 weapon system consisted of the XFIM 43C guided missile, the XM-171 launcher, the XM-571 MONOPAK shipping and storage container, and the AN/TSM-82 test set. None of the major components peculiar to the Block III XM-41E2 weapon was interchangeable with like items in the XM-41 or XM-41E1 systems.

(U) Major components of the Block III (43C) missile included the Mod 60A gas cooled seeker head; the XM-221 warhead section, with the XM-222 warhead and new XM-814 "canned" fuze; and the XM-115 rocket motor. All major sections were designed to accommodate the separable joint changes in the missile. The XM-171 launcher used the XM-62 open sight and a new electronic package to accommodate changes in the missile electronic gear. The complete weapon (missile/launcher) weighed 29.3 pounds, in contrast to a base weight requirement of 22 pounds set in the modified MC's.

(U) The XM-571 MONOPAK container was developed as a replacement for the XM-547 TRIPAK container, which was considered too heavy and too large for two men to handle in the field. Also, there were logistics problems associated with packaging three weapons in one container. The MONOPAK was designed to carry one complete weapon and three battery and coolant (Freon) units. Made of aluminum and lined with polyurethane, it weighed 44 pounds empty and 76 pounds loaded, in contrast to an empty weight of 68 pounds and a loaded weight of 164 pounds for the TRIPAK. In June 1966, MICOM let a contract to Halliburton Enterprises for production of the MONOPAK container. The TRIPAK was to remain in use until all Block I and Block II weapons were expended.²⁹

²⁹(1) Hist Rept, REDEYE PM, FY 1966. (2) REDEYE PM₂P, 31 Dec 66, pp. 2, 39. (3) AMC TIR 21.1.6.1(2), Dec 66, pp. 12-13. RSIC. (4) AMCTCM 5004, 5 Jan 67. RSIC.

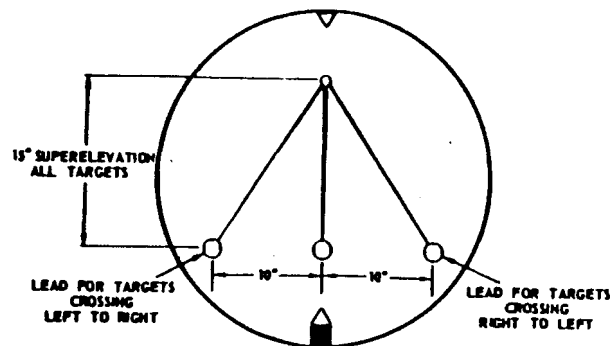
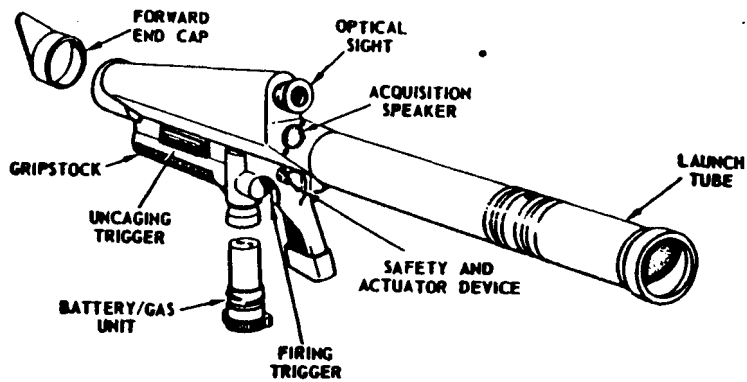

XM-147/XM-147E1 (Block I/II) Launcher

134

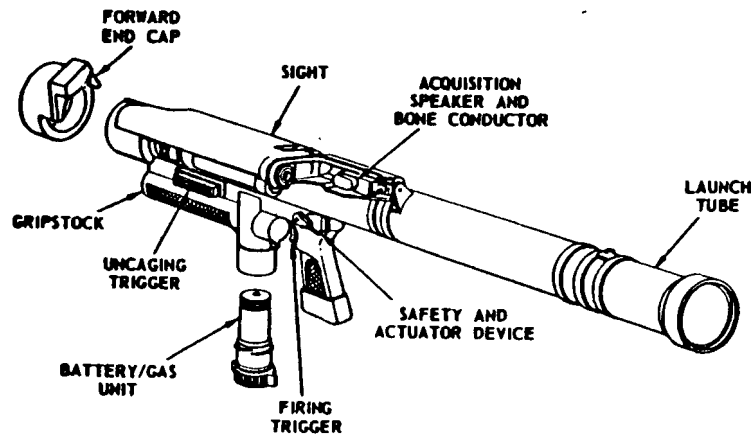
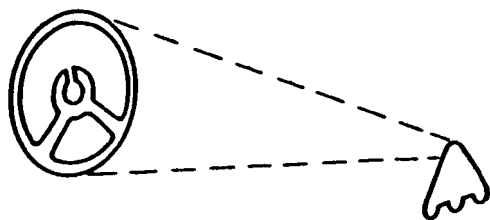

XM-171 (Block III) Launcher

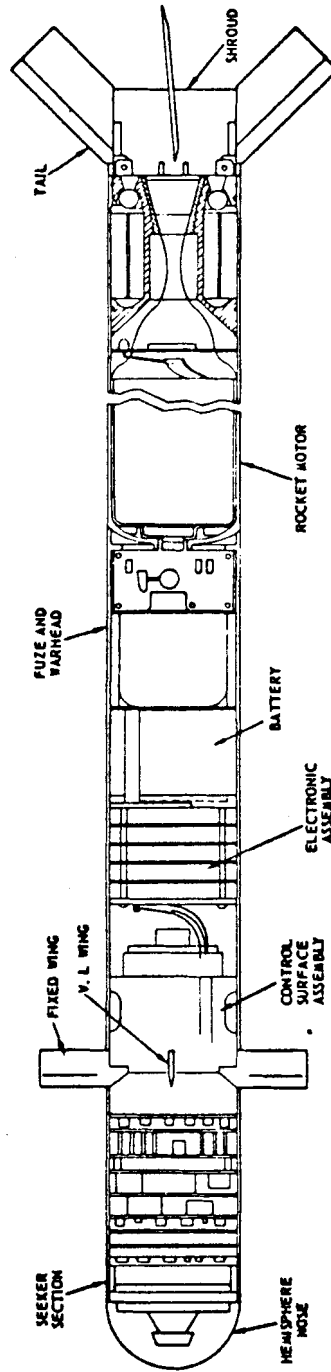

Cutaway View of XFIM 43C (Block III) REEYE Missile

(U) Delivery of the Block I missiles began in September 1965 and continued into May 1966, overlapping initial deliveries of Block II systems which commenced in April 1966. The integrated engineering test/service test (ET/ST) program got underway at White Sands in September 1965, and service evaluation tests started 2 months later. The engineering evaluation test program, which began at NOTS in June 1964, was completed in April 1966.³⁰

(U) During FY 1966, 215 missiles of the Mod 60A design were fired in the various test programs. These included 22 engineer tests (preproduction missiles - all telemetry); 96 service tests (production missiles - 36 warhead, 60 telemetry); 15 Block III engineering evaluation tests (EGTV's - all telemetry); 64 product assurance tests (production missiles - 2 warhead, 62 telemetry); 12 qualification tests (production prototypes - 5 warhead, 7 telemetry); 5 new equipment training tests; and 1 Navy test. As shown below, 62 of the 215 test rounds scored physical intercepts, 36 passed within less than 6 feet of the IR centroid, and 14 were reliable rounds with a miss distance of more than 6 feet.³¹

Test Program	Rounds Fired	Miss Distance			No Test	Improper Operation
		0	-6 Ft	+6 Ft		
Engineer.....	22	1	3		15*	3
Service.....	96	29	18	6	10	33
Product Assurance...	64	14	7	8	14	21
Qualification.....	12	9	1		1	1
Engineering Eval....	15	7	5		1	2
New Equipment Tng...	5	2	1		1	1
Navy Test.....	1		1			
	<u>215</u>	<u>62</u>	<u>36</u>	<u>14</u>	<u>42</u>	<u>61</u>

* The large number of invalid tests attributed to the type of testing; i.e., deliberately firing beyond system capabilities to determine actual performance parameters.

(U) The results of service and industrial test firings of

³⁰ REDEYE PM₂P, 31 Dec 66, pp. 25-26. Hist Div File.

³¹ Hist Rept, REDEYE PM, FY 1966, pp. 18-19. Hist Div File.

Block I production missiles, in March, April, and May of 1966, reflected a significant drop in system reliability. The REDEYE Project Manager promptly halted final assembly of tactical Block II systems, effective 24 May 1966, and formed a reliability steering committee to evaluate the test failures and recommend corrective action. The test failures were generally grouped into the following areas: no warm-up, no eject, launcher end cap failure, late or no sustainer ignition, and flight inaccuracy. In late June 1966, the steering committee completed its evaluation of these failures and positive corrective action was initiated. The stop work order issued against Contract AMC-644 was lifted on 30 June.³²

(U) The Test & Evaluation Command's Arctic Test Center at Fort Greely, Alaska, completed the cold weather phase of the Block II system service test program in the spring of 1966. Seventeen weapons were fired after being exposed to severe arctic weather conditions and field handling. These rigid "torture tests" showed that the REDEYE equipment and operating personnel could perform successfully in an extremely cold environment.³³ Other phases of the service test program included firings and field handling under temperate conditions at Fort Bliss, Texas; under an infantry environment at Fort Benning, Georgia; under an airborne environment at Fort Bragg, North Carolina; under an artillery environment at Fort Sill, Oklahoma; and under an armored environment at Fort Knox, Kentucky and Fort Stewart, Georgia. Storage, field handling, and firing tests under tropical conditions were conducted at Fort Clayton, Canal Zone.³⁴

³²(1) *Ibid.*, pp. 3-5. (2) REDEYE PM₂P, 31 Dec 66, p. 47. (3) P&PD Rept, Monthly Sta Rept of Delinquent Dlvry, May 66. (4) P&PD Rept, Perf of Selected Contrs (AMC-644), Jun 66. All in Hist Div File.

³³*Army Research and Development Newsmagazine*, Vol. 7, No. 5, May 66, p. 23.

³⁴Hist Rept, REDEYE PM, FY 1966, p. 15. Hist Div File.

FY 1967

(U) As a result of technical difficulties encountered in meeting the Block II and III system production schedules and the continued engineering changes, the programmed buy for FY 1967 was deferred to FY 1968. General Dynamics and its subcontractor were unable to produce quality gyro/optics assemblies at the required rate to meet Block II missile deliveries, and Picatinny Arsenal had problems producing a fully reliable fuze for the Block III warhead. Consequently, only limited quantities of complete round missiles and equipment became available for engineering and service testing, initial gunner training, and for distribution to equip and support planned REDEYE team deployments.

(U) The difficulties at Picatinny Arsenal stemmed from failure of the XM-814 fuze to perform consistently within specified time requirements. Among the major causes of the problem were faulty springs, improper tolerances on the fuze body, and inadequate staking of the fuze mechanism to the body. These problems were corrected, and warhead section deliveries were resumed in the spring of 1967. Initial delivery rates, however, were not adequate to support the projected Block III weapon production.

(U) General Dynamics was the sole producer of gyro/optics for the latter portion of the FY 1965 (Block II) production contract, the Miniature Precision Bearing Company having completed its production. The Norden Corporation and General Dynamics produced gyro/optics to support the FY 1966 (Block III) production contract (AMC-990). Start-up problems at Norden, coupled with production difficulties at General Dynamics, caused a slippage in Block II weapon deliveries under Contract AMC-644.³⁵

³⁵(1) REDEYE PM₂P's, 31 Dec 66, p. 47; 31 Mar 67, p. 47. (2) AMC Hist Sum, FY 1967, p. 176. (3) Hist Rept, REDEYE PM, FY 1967, p. 2. All in Hist Div File.

UNCLASSIFIED

~~CONFIDENTIAL~~

The integrated ET/ST and service test programs were completed in January 1967. An interim release of the XM-41E1 system, which was to be distributed only to the U. S. Army, Pacific (Korea), was authorized on 10 February 1967 to support Army troop training at Fort Bliss; however, it was not until 20 February 1967 that the first REDEYE tactical missiles were released as suitable for issue to the troops. Personnel of the 101st Airborne Division, who were the first to receive gunner training and participate in live Block II firings, were deployed from Fort Campbell, Kentucky, without a full load of equipment; and even this equipment was later withdrawn for redistribution to higher priority claimants in Korea.³⁶ User acceptance of the XM-41E2 (Block III) system, which was to make up the bulk of fielded weapons, was confirmed at the REDEYE In-Process Review (IPR) held at AMC on 28-29 November 1967.³⁷

The aforementioned production problems led to an increase in procurement costs that exceeded those included in the budget. The Army Materiel Command therefore requested \$13.9 million in additional FY 1966 program authority, but DA authorized an increase of only \$6 million and directed that the remaining \$7.9 million be deferred until FY 1969. In addition, DA directed AMC to offset the \$6 million increase by reducing procurement quantities for FY 1967-68. As a consequence, 1,639 missiles were cut from planned Army procurement, and Contract AMC-990 was renegotiated, in June 1967, to reflect the stretchout of deliveries.³⁸ The delivery of 10,985 Block III weapons under Contract AMC-990

³⁶ (1) AMC Hist Sum, FY 1967, pp. 176-77. (2) REDEYE PM₂P, 30 Sep 67, p. 26. Hist Div File.

³⁷ AMCTCM 6457, Oct 68. RSIC.

³⁸ (1) AMC Hist Sum, FY 1967, p. 177. (2) As stated earlier, the actual cost of the FY 1966 industrial program was \$71.6 million. See above, pp. 131-32.

~~CONFIDENTIAL~~

UNCLASSIFIED

~~UNCLASSIFIED~~

~~CONFIDENTIAL~~

began in November 1966 and continued into August 1968—a delivery period of 21 months instead of the 12 months originally scheduled.³⁹ Deliveries under Contract AMC-644 commenced in April 1966 and continued until May 1967, when Block II (XM-41E1) production was stopped so that guided missile test equipment could be converted to Block III. All told, 1,743 (instead of 1,754) Block II weapons and 49 guided missile test sets (AN/TSM-54 and AN/TSM-82) were delivered under the FY 1965 production contract.⁴⁰

(U) Except for the development of certain items of training equipment which will be discussed later, RDTE funding for the basic REDEYE system ended in FY 1967, with an expenditure of \$2,423,000. This brought the total development cost to \$76,767,000 for the FY 1958-67 period, \$10,500,000 of which was provided by the Marine Corps.⁴¹ Among the in-house development projects undertaken and essentially completed with FY 1967 funds were the missile redirack to transport two REDEYE weapons in a ready state on the M151A1, 1/4-ton truck, and the XM-585 UNIPAK shipping and storage container to replace the XM-571 MONOPAK. Made of polystyrene, the UNIPAK container was slightly smaller and weighed 26 pounds less than the MONOPAK. It was 10 inches wide, 15.5 inches high, and 56.5 inches long, and had a loaded weight of 50 pounds.⁴²

Combined FY 1967-68 Procurement

(U) The procurement of planned quantities of Block III

³⁹ P&PD Rept, Perf of Selected Contrs (AMC-990), Jul 68. Hist Div File.

⁴⁰ P&PD Repts, Perf of Selected Contrs (AMC-644), May, Jun, & Sep 67. Hist Div File.

⁴¹ ADSIMO Rept, REDEYE Wpn Sys R&D Funding, 20 Feb 73. Hist Div File.

⁴² (1) AMCTCM 5781, 25 Jan 68. RSIC. (2) Hist Rept, REDEYE PM, FY 1967, p. 7. Hist Div File. (3) REDEYE PM₂P, 30 Sep 68, p. 48. File same.

~~CONFIDENTIAL~~

UNCLASSIFIED

~~UNCLASSIFIED~~

~~CONFIDENTIAL~~

weapons for FY's 1967 and 1968 was combined under one contract. Since classification of the basic system as Standard A had been delayed pending completion of Type I Confirmatory Tests, the DA, on 20 March 1967, granted authority to extend the LP classification to cover the fourth production buy.⁴³ On 1 September 1967, a letter order contract for \$7.7 million was issued to General Dynamics for the purchase of long leadtime items. This action was definitized, on 29 December 1967, by the execution of an FPIF contract (DA-AH01-68-C-0274) for \$40.1 million for the production of 11,881 weapons—7,258 for FY 1967 and 4,623 for FY 1968. Engineering services support for FY 1967 had been provided through a \$3.9 million CPIF contract awarded on 30 September 1966. A follow-on contract for \$2.9 million extended engineering support through 30 September 1968.⁴⁴

(U) Beginning with the fourth production buy in FY 1968, the assembly of motor metal parts and propellant loading were procured from the Atlantic Research Corporation (ARC) as a direct breakout procurement action. The nozzle, motor case, and case liner were procured from General Dynamics and shipped to ARC as Government-furnished equipment (GFE). Previous buys of rocket motors had been with General Dynamics, which then subcontracted with ARC. On 29 December 1967, an FPIF contract for \$6.6 million was awarded to ARC for delivery of 11,984 loaded rocket motors over a period of 13 months.⁴⁵

(U) As in previous years, warheads/fuzes and batteries

⁴³ 1st Ind, ACSFOR to CG, AMC, 20 Mar 67, on Ltr, CG, AMC, to ACSFOR, 14 Mar 67, subj: GM Sys, Intcp Aerial, XM41E2, Req for Extension of LP TCLAS. Atchd to AMCTCM 5274, 18 May 67. RSIC.

⁴⁴ (1) Hist Repts, REDEYE PM, FY 1967, p. 2; FY 1968, p. 2. (2) P&PD Rept, Perf of Selected Contrs (DA-AH01-68-C-0274), Oct 68. Both in Hist Div File.

⁴⁵ (1) TT AMSMI-IRL-3-3-69, CG, MICOM, to CG, AMC, 1 Mar 69. (2) Hist Rept, REDEYE PM, FY 1968, p. 3. Both in Hist Div File.

~~CONFIDENTIAL~~

UNCLASSIFIED

~~UNCLASSIFIED~~

~~CONFIDENTIAL~~

continued to be furnished the prime contractor as GFE, contracted for and supplied by the Army Munitions Command and Army Electronics Command, respectively. The shipping and storage container, also a GFE item, was contracted for and supplied by the Army Missile Command. Although a decision had been made to use the lightweight UNIPAK container in lieu of the previously procured MONOPAK's, a delay in contracting for the new container necessitated an emergency buy of additional MONOPAK's to support weapon deliveries. A CPIF contract for \$677,765 was let to Halliburton Enterprises, on 20 May 1968, for 5,500 MONOPAK containers. This was followed, on 25 June, by the award of a firm-fixed-price (FFP) contract to the General Plastics Corporation for delivery of 9,249 UNIPAK containers at a cost of \$244,963. The UNIPAK container was to be used for the shipment and storage of Block III weapons for the last half of the fourth production buy and all subsequent buys.⁴⁶

(2) The actual cost of the FY 1967-68 industrial program (including training equipment, GFE, and in-house and indirect costs) totaled \$73,355,744.06. The Army's share of this cost was \$38,464,114.62. The Marine Corps paid \$28,277,433.30 of the total cost, and other customers, \$6,614,196.14.⁴⁷ Delivery of the 11,881 Block III weapons began in September 1968 and continued at the rate of about 1,000 per month during the next 11 months. Deliveries were completed on 29 September 1969.⁴⁸

⁴⁶ (1) *Ibid.*, pp. 3, 10-11. (2) MICOM Hist Sum, FY 1968, p. 95. (3) SS AMSMI-I-47-68, P&PD, 29 Mar 68, subj: Ppsd Awd to Halliburton Enterprises. Hist Div File.

⁴⁷ Rept, PEMA REDEYE Msl Sys Maj Items, 27 Jun 73, Budget Div, Compt. Hist Div File.

⁴⁸ P&PD Repts, Perf of Selected Contrs (DA-AH01-68-C-0274, Oct 68 & Sep 69. Hist Div File.

~~CONFIDENTIAL~~

~~UNCLASSIFIED~~

UNCLASSIFIED

~~**CONFIDENTIAL**~~

The Standard M41 Weapon System

Type Classification

6) The service test program was completed in January 1967, and an interim report on the Type I Confirmatory Test was submitted in September 1967. The XM-41E2 weapon system was certified for troop use in the temperate zone in October 1967, but the release for use in extreme climates had to await completion of final environmental tests then underway. User acceptance of the weapon system was confirmed during the IPR held at AMC on 28-29 November 1967. At that time, the Assistant Chief of Staff for Force Development (ACSFOR), the Office, Chief of Research and Development (OCRD), CONARC, and the Marine Corps all agreed that the XM-41E2 system was ready for classification as Standard A. However, the Combat Developments Command (CDC) opposed the action, preferring to postpone type classification pending improvements in the open sight, a more detailed evaluation of the stationary target problem, and completion of the Army/Marine Corps arctic confirmatory (Type I) test. While sustaining the majority view that the REDEYE was ready for standardization, AMC deferred the technical committee action per recommendations of CDC.⁴⁹

6) Evaluation of the Block III open sight had been conducted early in 1967, as a part of the Type I Confirmatory Test Program. In an interim letter report of the evaluation, issued in May 1967, the U. S. Army Air Defense Board pointed to several undesirable human factor features of the weapon open sight. Two major solutions to the problem were considered: one designed to eliminate fuzziness of the reticle caused by the inability of the eye to focus on it, and the other to provide maximum eye

⁴⁹ (1) AMCTCM 6457, Oct 68. RSIC. (2) REDEYE PM₂P, 30 Jun 68, p. 31. Hist Div File.

~~**CONFIDENTIAL**~~

UNCLASSIFIED

~~UNCLASSIFIED~~
~~CONFIDENTIAL~~

relief. In view of the retrofit costs involved and the limited improvements in gunner effectiveness, AMC decided, in January 1968, to continue production of the existing sight configuration.⁵⁰

(C) The degradation of missile accuracy against very slow moving targets was the subject of a study by the REDEYE Project Office. It was determined from this study that the degradation in performance was minor and could be overcome by proper deployment in a tactical situation. Although a design to improve weapon performance against stationary or very slow moving targets was readily available, its impact on other performance parameters could not be established without an extensive test and evaluation program. Upon completion of such an evaluation, the production program would have progressed to a point that few weapons would remain for incorporation of the fix, even if it were established as desirable. Consequently, the REDEYE Project Manager advised CDC that no further effort was planned on the problem.⁵¹

(U) The final arctic environmental tests at Fort Greely, Alaska, were completed early in 1968 with no problems. The tests verified the REDEYE's operational capability and reliability after typical open storage at -40° and cross-country handling trials.⁵² The XM-41E2 system was approved for troop use in extreme climates in October 1968.⁵³

(C) Although virtually all conditions for standardization of

⁵⁰ (1) Ltr, DCG, AMC, to CRD, DA, 5 Feb 68, subj: REDEYE Open Sight IPR. Atchd as incl to Ltr, Chf, Program Mgt Ofc, REDEYE Proj Ofc, to CG, AMC, *et al.*, 9 Feb 68, subj: same. Hist Div File. (2) AMCTCM 6457, Oct 68. RSIC.

⁵¹ (1) *Ibid.* (2) Ltr, REDEYE PM to CG, CDC, 10 Apr 68, subj: Slow Speed Tgt Perf. Atchd to AMCTCM 6791, Apr 69. RSIC.

⁵² *Army Research and Development Newsmagazine*, Vol. 9, No. 6, Jun 68, p. 16.

⁵³ REDEYE PMP, 30 Sep 69, p. 32. Hist Div File.

~~CONFIDENTIAL~~
UNCLASSIFIED

UNCLASSIFIED

~~**CONFIDENTIAL**~~

the system had been met by the end of May 1968, the staffing time required for the technical committee action made it necessary to obtain another extension of the LP classification, in order to execute the FY 1969 procurement program on schedule. On 29 July 1968, ACSFOR approved the LP classification for procurement of 2,400 additional XM-41E2 weapon systems for FY 1969. At the same time, the Block II XM-41E1 weapon system was reclassified from LP to contingency and training type.⁵⁴

(U) The Block III XM-41E2 weapon system was officially reclassified from LP to Standard A on 18 December 1968.⁵⁵ The Guided Missile Test Set AN/TSM-82 (XO-1) and Test Set Test Equipment TS-2554 (XO-1)/GSM were type classified by a separate action. The standard M41 (XM-41E2) guided missile system consisted of the following major items and components:⁵⁶

Guided Missile, Intercept-Aerial: FIM-43C
Warhead Section: M221 (XM-221E2)
Warhead, High Explosive: M222 (XM-222)
Fuze: M814 (XM-814E1)
Rocket Motor: M115 (XM-115)

Launcher, Tubular, Guided Missile: M171 (XM-171)

Container, Shipping & Storage: M585 (XM-585) (UNIPAK)

The principal characteristics and performance capabilities of the standard M41 REDEYE weapon system are shown in the accompanying tables.

⁵⁴ Ltr, REDEYE PM to ACSFOR, 31 May 68, subj: GM Sys Intcp Aerial, XM-41E2, Req for Extension of LP TCLAS, & 1st Ind, ACSFOR to CG, AMC, 29 Jul 68. Atchd to AMCTCM 6457, Oct 68. RSIC.

⁵⁵ 1st Ind, ACSFOR to CG, AMC, 18 Dec 68, on Ltr, REDEYE PM to ACSFOR, 18 Oct 68, subj: Req for Apprl, STD-A. Atchd to AMCTCM 6791, Apr 69. RSIC.

⁵⁶ AMCTCM's 6791, Apr 69; 7057, Aug 69; 7170, Oct 69. RSIC.

~~**CONFIDENTIAL**~~

UNCLASSIFIED

~~UNCLASSIFIED~~

~~CONFIDENTIAL~~

TABLE 2— (U) M41 REDEYE System Characteristics (U)

MISSILE

Weight.....	18.3 lbs.
Length.....	47.5 in.
Diameter.....	2.75 in.
Warhead:	
Type.....	Internal Blast, After Penetration
Weight.....	2.35 lbs.
Explosive.....	0.8 lb. HTA-3 (See p. 65)
Fuze.....	Penetration-Impulse Generator with Impact Switch
Fins.....	4 Folding
Control Surfaces.....	4 Extensible Wings
Rocket Motor:	
Type.....	Dual Thrust w/Separate Ejector
Weight.....	10 lbs.
Length.....	25 in.
Diameter.....	2.75 in.
Booster (Ejector)	
Propellant.....	40 Grains (0.23 lb.) Arcite 386M, Composite, Solid
Burning Time.....	0.048 sec.
Thrust.....	750 lbs.
Sustainer	
Propellant.....	Single Inhibited Grain 427B Arcite, Composite, Solid, w/19 Silver Wires
Casing.....	H-11 Deep Drawn Steel
Weight.....	6.08 lbs.
Burning Time.....	5.8 secs.
Nominal Thrust.....	250 lbs.
Total Impulse.....	1,350 lb. secs.
Guidance	
Type.....	Passive, Homing All the Way
Seeker.....	Infrared w/Gas Cooled PbS Detector
Power Supply.....	BA-627 Battery

LAUNCHER

Type.....	Unitized, Expendable
Weight.....	11 lbs.
Length.....	49.7 in.
Components.....	Launching Tube; Open Sight w/Target Acquisition Indicator; & Stock w/ BA-628 Thermal Battery, Missile Coolant, Firing Mechanism, and Electronics.

SOURCE: (1) REDEYE PMP, 31 Mar 70, pp. 39-40. (2) AMC TIR
21.1.6.1(2), Dec 66.

~~CONFIDENTIAL~~

UNCLASSIFIED

TABLE 3—() M41 REDEYE System Capabilities vs MC's (U)

<u>Characteristic</u>	<u>Requirement</u>	<u>Status as of 31 Mar 70</u>
Weapon Weight	22 lbs.	29.3 lbs. ^{a/}
Speed	400 knots	439 knots
Altitude	9,000 feet	9,008 feet ^{b/}
Slant Range	4,100 meters	4,532 meters
Target Maneuver	2 g's	3.0 g's ^{c/}
Single-Shot Kill Probability	0.3 (Jet) 0.5 (Other)	0.403 (MIG-21 Jet) ^{d/} 0.53 (MI-6 Helicopter; U.S. H-13 & H-21 Helicopters) 0.43 (AN-12 Cub)
Reliability	90% Minimum	92% (Operational)
Warm-Up Time	5 sec. Maximum	4.3 sec. Maximum
Temperature Limits	-45°F. to +140°F.	-45°F. to +140°F.

NOTES

^{a/} Contractor was unable to miniaturize the weapon to meet the modified weight requirement and still meet performance specifications.

^{b/} 9,008 feet was the highest altitude attempted for a production weapon in a fully instrumented valid test.

^{c/} Computer simulations indicated that the system had a 6-g capability.

^{d/} Actual kill probability against U. S. droned F9F tactical aircraft was 0.51 at 100-meter altitude and 430-knot speed.

SOURCE: REDEYE PMP, 31 Mar 70, pp. 37-38.

UNCLASSIFIED

~~CONFIDENTIAL~~

148

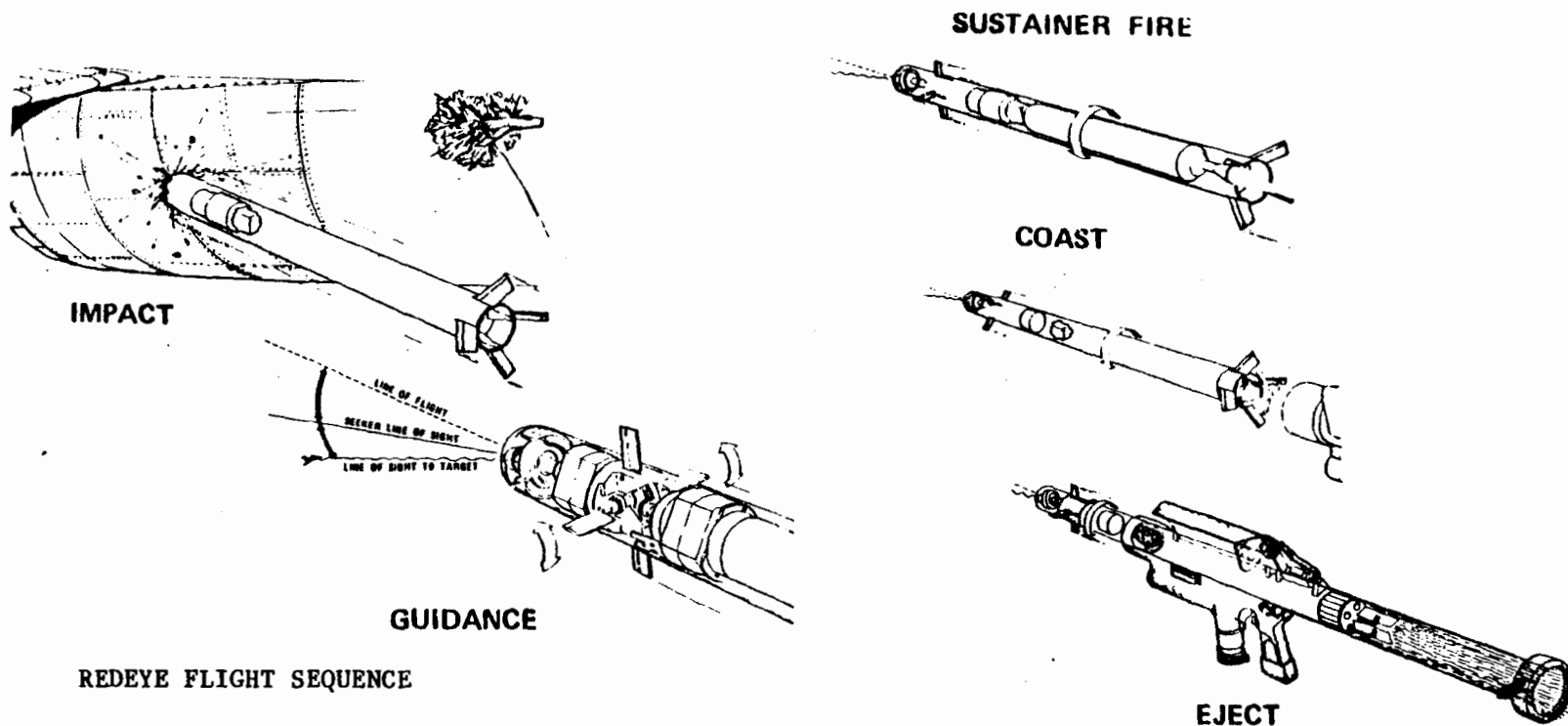

REDEYE FLIGHT SEQUENCE

1. Eject - The ejector accelerates the missile to about 80 fps. The fuze timer is started when ejector acceleration reaches 28 g's. The ejector gases impinging on the folded tails initiates missile roll. Burnout occurs before the missile clears the launch tube.
2. Coast - The missile coasts for about 20 feet before the sustainer is ignited.
3. Sustainer Fire - At the end of the coast phase, the sustainer motor is ignited by a pulse from the fuze timer. The missile accelerates to a peak velocity of about Mach 1.7 in 5.8 seconds. The warhead is armed about 1.25 seconds after sustainer ignition.
4. Guidance - Throughout the flight, the seeker passively tracks the target and the control section guides the missile on a proportional navigation course to intercept with the target.
5. Impact and Warhead Detonation - The warhead is detonated when the missile penetrates the target. A fixed time self-destruct destroys the missile in case of a miss.

UNCLASSIFIED

~~CONFIDENTIAL~~

REDEYE WEAPON SYSTEM

7 MARCH 1969

INTERCEPT
AERIAL
TRAINERS

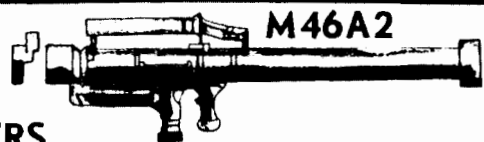

M46A2

WEAPON ROUND
M41



XM76 TRAINING SET



BATTERY CHARGER

ADDITIONAL
OPERATIONS
MANUAL

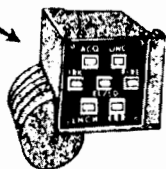

SHIPPING AND STORAGE
CONTAINERS

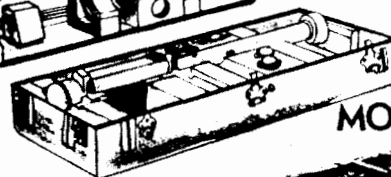
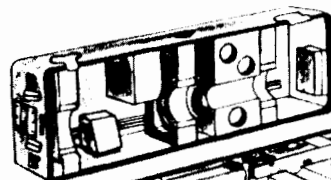

MONOPAK

UNIPAK



Guided
Missile
Test Set

XM-82

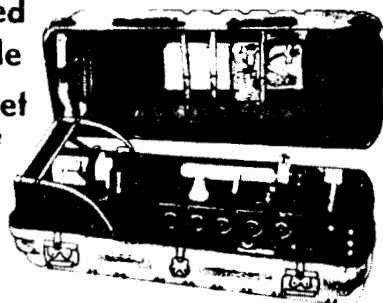

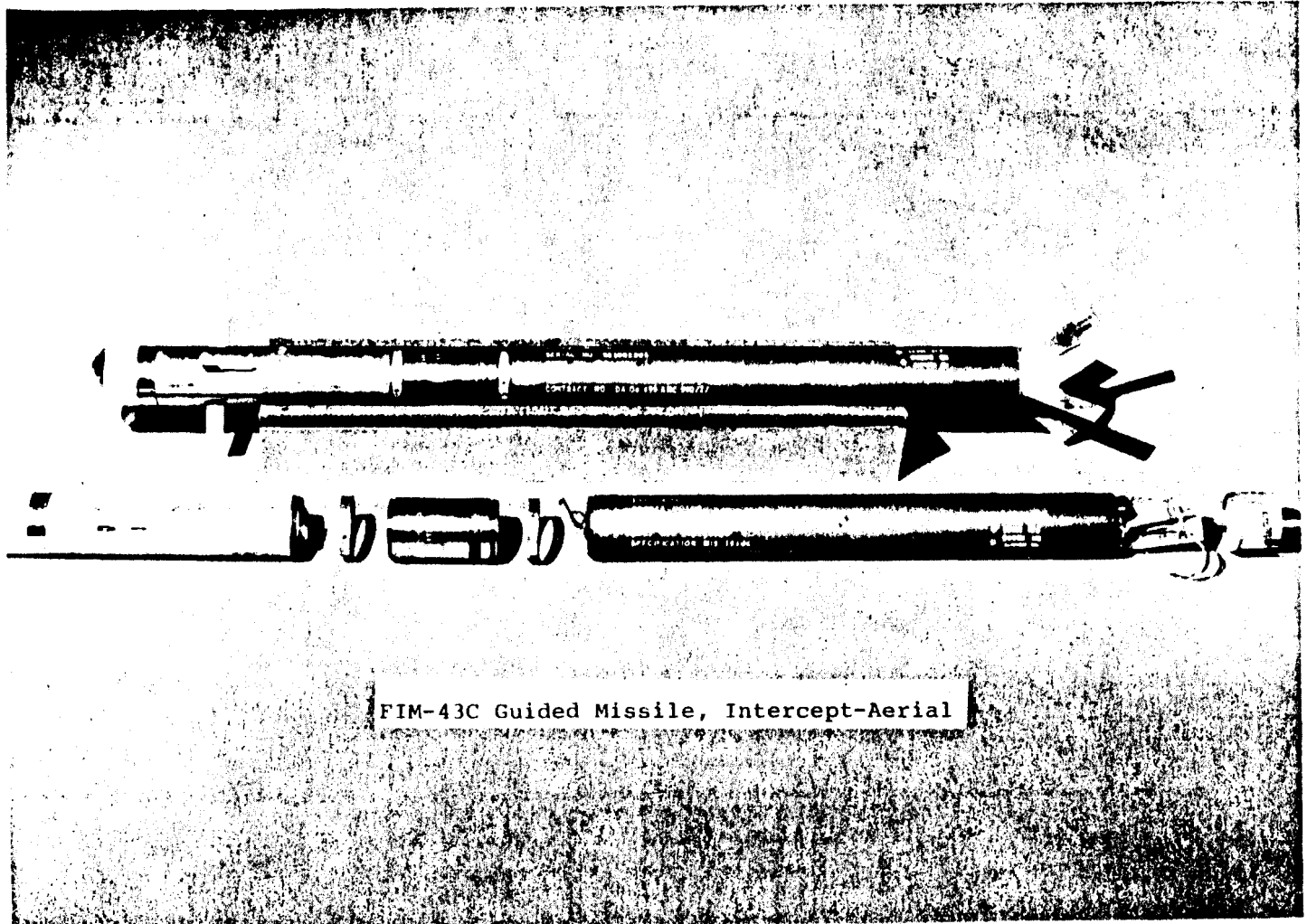

REDEYE LAUNCHER SECTION

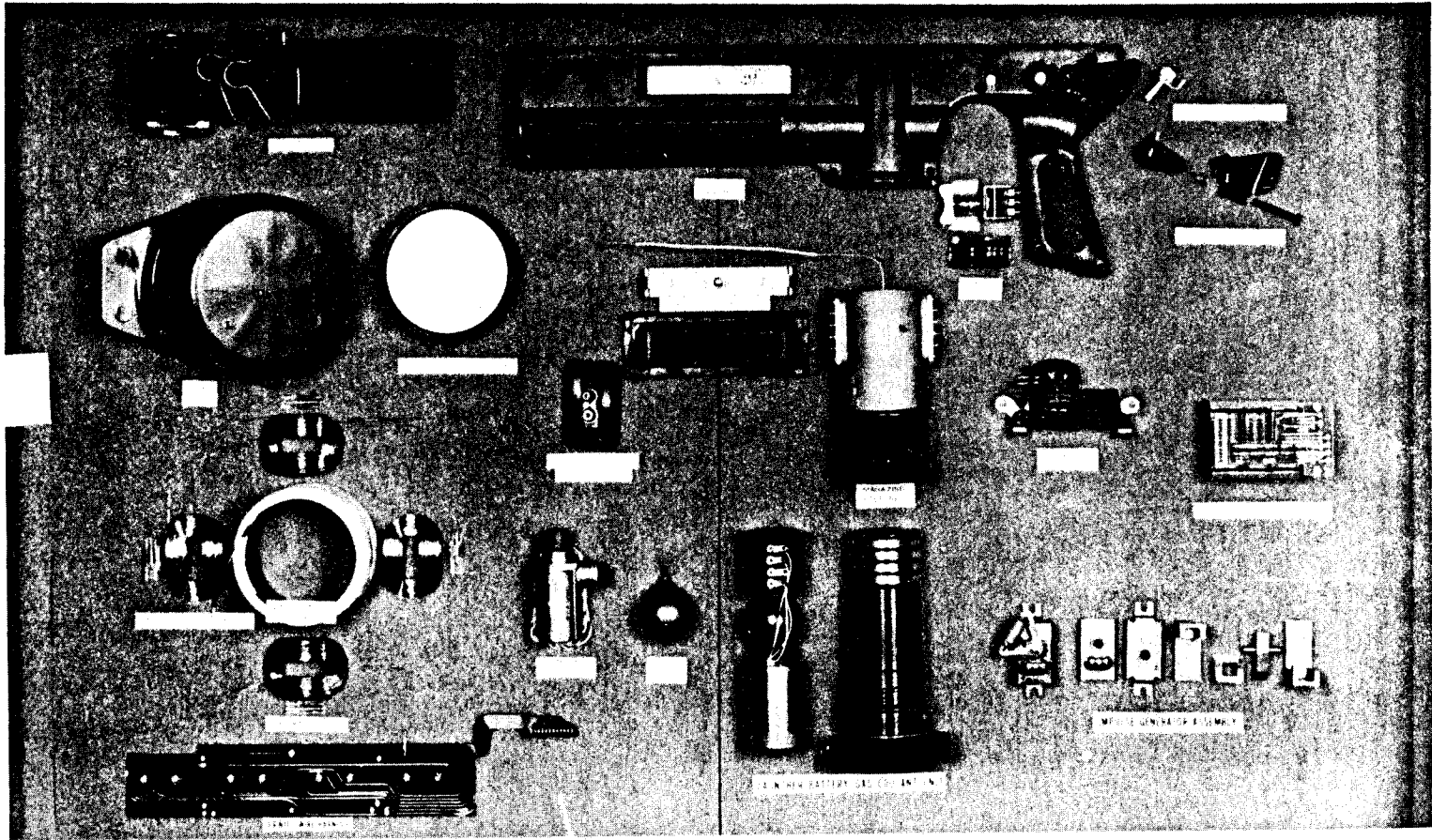

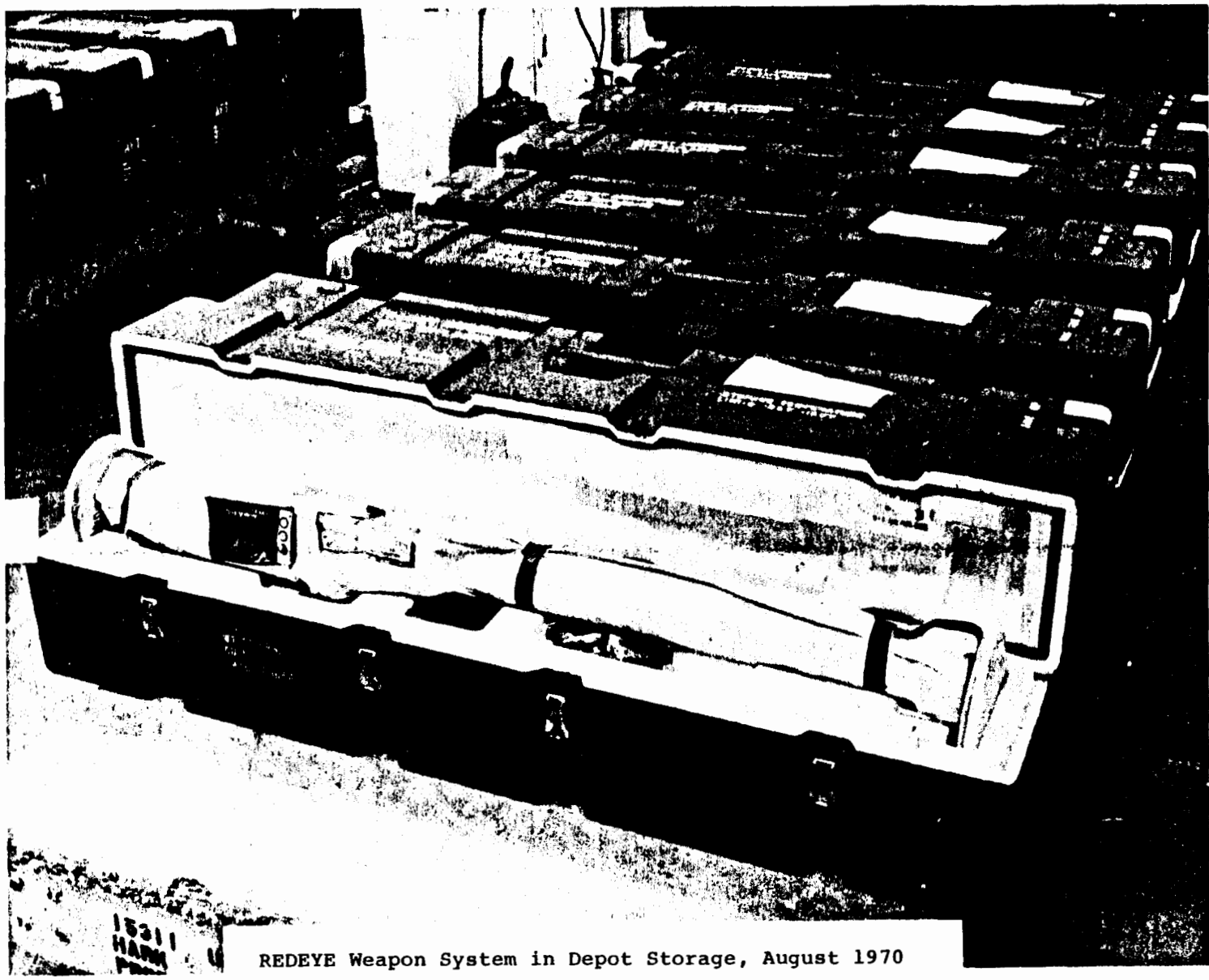

REDEYE Weapon System in Depot Storage, August 1970

1531
HARM
FR

~~UNCLASSIFIED~~

~~CONFIDENTIAL~~

FY 1969-73 Procurements

At the time of the type classification action, the planned worldwide assets consisted of 34,801 REDEYE weapons—25,715 for the U. S. Army and 9,086 for the Marine Corps and other customers.⁵⁷ The Army's authorization, however, was later cut to 20,755, including 140 RDTE rounds. Army procurement of the basic configuration REDEYE was terminated with the purchase of 2,400 units in FY 1969 and a final lot of 2,400 in FY 1970. This was expected to meet Army requirements through FY 1975. The only other procurement of the basic REDEYE during the FY 1969-73 period consisted of 1,558 weapons for Foreign Military Sales (FMS) in FY 1972-73. With the 24,910 weapons procured prior to FY 1969, the worldwide assets thus totaled 31,268—20,755 for the U. S. Army, 7,637 for the U. S. Marine Corps, and 2,876 for other customers.⁵⁸

In July 1968, the Department of the Army released FY 1969 program authority to procure 2,400 missiles at the rate of 200 per month, which was 800 per month below the economic procurement quantity.⁵⁹ On 19 September 1968, General Dynamics was awarded an FPIF contract (DA-AH01-69-C-0231) for \$11.6 million for production of 2,400 complete REDEYE weapons. A CPIF contract for \$2.2 million went to General Dynamics on 30 October 1968 for follow-on engineering services for 12 months, and the Atlantic Research Corporation received a \$1.6 million FPIF contract on 29 November for production of 2,424 rocket motors. Since the General Plastics Corporation was unable to deliver UNIPAK containers to keep pace with weapon production, the Government contracted with the Zero

⁵⁷ AMCTCM 6791, Apr 69. RSIC.

⁵⁸ (1) AMC Hist Sum, FY 1969, p. 240. (2) ADSIMO Rept, REDEYE Distr Planning Info, 30 Jun 73, p. 7. Hist Div File.

⁵⁹ AMC Hist Sum, FY 1969, p. 240.

~~CONFIDENTIAL~~

UNCLASSIFIED

~~UNCLASSIFIED~~

~~CONFIDENTIAL~~

Manufacturing Company to refurbish about 750 reusable MONOPAK containers.⁶⁰

(U) Contract DA-AH01-70-C-0120, for \$11 million, was issued to General Dynamics, on 2 October 1969, for the final Army buy of 2,400 weapons. General Dynamics also received an engineering services contract for \$2.2 million. The Atlantic Research Corporation was awarded a \$2.2 million FFP contract for production of 2,448 rocket motors, and the General Plastics Corporation won a \$112,669 contract for 2,689 UNIPAK containers.⁶¹

(U) There were no weapon system purchases in FY 1971. The PEMA program for that year consisted primarily of an extension of the FY 1970 engineering services contract with General Dynamics and contracts with Aircraft Armaments, Inc., for production and engineering services support of moving target simulators.⁶²

(U) Except for the Army procurement of additional moving target simulators, the FY 1972 program consisted of purchases for Foreign Military Sales (FMS). In December 1971, General Dynamics received an \$8 million contract (DA-AH01-72-C-0377) for 818 REDEYE weapons for the Federal Republic of Germany (FRG). This contract was modified in June 1972 to procure 470 weapons for Denmark at a cost of \$2.8 million. In FY 1973, Contract 0377 was again modified for add-on quantities of 200 for FRG and 70 for Denmark, making a total of 1,558 weapons. The total value of the contract as of 1 April 1973 was \$13,020,910.⁶³ Army expenditures for the

⁶⁰Hist Rept, REDEYE PM, FY 1969. Hist Div File.

⁶¹*Ibid.*, FY 1970.

⁶²Hist Rept, ADSIMO, FY 1971. Hist Div File.

⁶³(1) MICOM Hist Sum, FY 1972, pp. 75-76. (2) DF, ADSIMO to Cdr, MICOM, 15 Sep 72, subj: ADSIMO Weekly Significant Actions, Week Ending 15 Sep 72. (3) ADSIMO Repts, Sta Rept of Delinquent Dlvrys--Pdn Scds [Re: Contr 0377], Dec 72 & Apr 73. (4) P&PD Rept, Contr Listings, 1 Apr 73, p. 92. All in Hist Div File.

~~CONFIDENTIAL~~

UNCLASSIFIED

UNCLASSIFIED

~~CONFIDENTIAL~~

REDEYE industrial program ended in FY 1972.

(U) The actual cost of the REDEYE industrial program for the FY 1969-73 period (including GFE, training equipment, and in-house and indirect costs) totaled \$62,239,460.23. Of that sum, \$46,086,212.73 was for Army procurements and the remaining \$16,153,247.50 for foreign military sales.⁶⁴

Weapon System Procurement Summary

(U) All told, 31,268 REDEYE weapon systems were procured during the FY 1964-73 period. Of these, 301 were Block I XM-41 weapons, 1,743 were Block II XM-41E1, and 29,224 were the tactical Block III M41 (XM-41E2) system (see Table 4). As noted earlier in this chapter, the Block I weapons were expended in engineering and service tests. Some of the LP Block II XM-41E1 weapons were deployed with U. S. Army units in Korea in 1967, but were later supplanted by standard Block III systems. These replaced systems, together with the balance of the Block II lot, were used in CONARC training programs. The broad distribution of weapon systems produced is shown below.⁶⁵

<u>U. S. Claimants</u>		<u>Foreign Military Sales</u>	
U. S. Army	20,615	Australia	216
RDTE/Army	140	Sweden	1,093
U. S. Marine Corps	7,637	FRG	1,018
U. S. Air Force	9	Denmark	540
	<u>28,401</u>		<u>2,867</u>

(U) Excluding items of training equipment, the development and procurement of which will be discussed in the next chapter, the support equipment procured for the REDEYE weapon system

⁶⁴ Rept, PEMA REDEYE Msl Sys Maj Items, 27 Jun 73, Budget Div, Compt. Hist Div File.

⁶⁵ (1) AMCTCM 6791, Apr 69. RSIC. (2) ADSIMO Rept, REDEYE Distr Planning Info, 30 Jun 73, p. 7. Hist Div File. (3) Intvw, M. T. Cagle w B. C. Latham, ADSIMO, 27 Jul 73.

~~CONFIDENTIAL~~

UNCLASSIFIED

TABLE 4—(●) Major Production Contracts with General Dynamics/Pomona (U)

FY	Quantity/Config.	Contract Number	Date	Contract Value*	Status*
1964	301 - Blk I ^{a/}	DA-04-495-AMC-412	Apr 64	\$ 8,240,710	Closed Out
1965	1,743 - Blk II	DA-04-495-AMC-644	Apr 65	21,853,926	Closed Out
1966	10,985 - Blk III	DA-04-495-AMC-990	Oct 65	52,574,787	Closed Out
1967-68	11,881 - Blk III ^{b/}	DA-AH01-68-C-0274	Sep 67	38,796,967	Closed Out
1969	2,400 - Blk III	DA-AH01-69-C-0231	Sep 68	10,866,095	Closed Out
1970	2,400 - Blk III	DA-AH01-70-C-0120	Oct 69	10,127,139	Closed Out
1972-73	<u>1,558</u> - Blk III ^{c/}	DA-AH01-72-C-0377	Dec 71	<u>13,388,870</u>	Active
	31,268			\$155,848,494	

* As of 20 August 1973. All cost data except for Contract AMC-412 furnished by Cecil L. Endsley, P&PD, 20 August 1973. Cost for AMC-412 based on documents cited in footnote 5, p. 124.

^{a/} Procured in FY 1964 with FY 1963 funds. Includes 140 RDTE rounds.

^{b/} FY 1967 procurement deferred to FY 1968. Quantity includes 7,258 with FY 1967 funds and 4,623 with FY 1968 funds.

^{c/} Includes buy of 1,288 in FY 1972 and 270 in FY 1973.

UNCLASSIFIED

~~CONFIDENTIAL~~

156

UNCLASSIFIED

~~CONFIDENTIAL~~

consisted of four major items, as follows:⁶⁶

<u>Item</u>	<u>Quantity</u>
Guided Missile Test Set, AN/TSM-82	69
Guided Missile Test Set Test Equipment	41
REDEYE Maintenance Shelter	13
Weapon Surveillance Test Equipment	2

(U) The actual cost of the REDEYE industrial program totaled \$268,430,783.10 for the FY 1964-73 period. Table 5 shows a cost breakdown by fiscal year and funding source.

Air Force and Navy Applications

(U) During the FY 1966-71 period, the Air Force and Navy purchased \$128,478 worth of hardware⁶⁷ to explore the feasibility of using the REDEYE in air-to-air, air-to-ground, and at-sea environments.

Air Force RAM Program

(U) In accordance with Southeast Asia (SEA) Operational Requirement 81, dated 15 March 1967, the U. S. Air Force undertook the development of a missile system that would be capable of accurate guidance from a maneuvering aircraft against a maneuvering target, and also possess a short range capability. In late 1967, the Air Force conducted Phase A of the REDEYE Air-Launched Missile (RAM) program. These Phase A tests were followed by a limited Phase B program, in which 2 launch pods and 26 modified REDEYE missiles were fabricated and tested. The basic REDEYE missiles were adapted for air-launch by wiring the ejector and sustainer motors together for simultaneous ignition and by lengthening the tail fins to provide greater airframe stability.

⁶⁶ (1) REDEYE PMP, 31 Mar 70, pp. 51-54. (2) ADSIMO Rept, REDEYE Wpn Sys Spt Items, 28 Jun 73. Both in Hist Div File.

⁶⁷ See Table 5.

TABLE 5— PEMA Cost Summary - REDEYE Missile System Major Items^{a/} (U)

FY	U. S. Army	U. S. Marine Corps	U. S. Air Force	U. S. Navy	Other	Fgn Mil Sales	Total
1964 ^{b/}	\$ 12,341,645.98	\$12,765,439.58					\$ 25,107,085.56
1965	25,371,025.79	10,710,234.05					36,081,259.84
1966	59,995,944.64	11,528,504.98		\$ 9,914.11		\$ 112,869.68	71,647,233.41
1967	27,240,611.25	11,533,690.53	\$24,101.00	2,400.00		819,832.94	39,620,635.72
1968	11,223,503.37	16,743,742.77	34,303.89	305.00		5,733,253.31	33,735,108.34
1969	19,679,017.52		1,600.00		\$ 1,195.00	618.00	19,682,430.52
1970	22,654,605.72		58.00	42,150.00	11,597.00	5,083.88	22,713,494.60
1971	952,600.12		2,406.00	11,240.00			966,246.12
1972	2,799,989.37					14,234,645.80	17,034,635.17
1973						1,842,653.82	1,842,653.82
	\$182,258,943.76	\$63,281,611.91	\$62,468.89	\$66,009.11	\$12,792.00	\$22,748,957.43	\$268,430,783.10

^{a/} Including GFE, test and training equipment, and in-house and indirect costs.

^{b/} Procurement in FY 1964 with FY 1963 funds.

SOURCE: Rept, PEMA REDEYE Msl Sys Maj Items, 27 Jun 73, Budget Div, Compt (Compiled from PEMARS Schedule D, 31 May 1973).

UNCLASSIFIED

CONFIDENTIAL

158

UNCLASSIFIED
CONFIDENTIAL

UNCLASSIFIED

~~CONFIDENTIAL~~

The RAM rounds were fired from a high performance F-4 aircraft in both phases. The Phase B firings were conducted at White Sands Missile Range, Holloman Air Force Base, and Eglin Air Force Base. After evaluating the results of these tests, the Aeronautical Systems Division of the Air Force Systems Command dropped the RAM from consideration as an air-to-air missile because of its operational restrictions in a supersonic launch, program costs, and nonavailability.⁶⁸

Helicopter RAM Program

The Helicopter RAM Program began in late June 1968, when General Dynamics was awarded a 12-week contract to determine the feasibility of using the REDEYE as an anti-helicopter and anti-truck system. This program was originally conceived to develop a helicopter-borne system that would be capable of countering any future enemy armed helicopter threat. As the program progressed, however, the emphasis was shifted to development of a more urgently needed air-to-ground anti-truck system. As in the case of the aircraft RAM, the basic REDEYE missile was modified for helicopter-launch by wiring together the ejector and sustainer motors for simultaneous ignition. Initial tests, in FY 1969, included the installation and checkout of launch pod/helicopter interface equipment and the conduct of acquisition and firing tests. Early in 1970, additional acquisition and firing tests, this time with the improved lead selenide (PbSe) seeker, were conducted to evaluate the anti-truck capability of the helicopter-borne system. Flight tests of five guidance test vehicles and one control test vehicle were completely successful. The Army Materiel Systems Analysis Agency (AMSAA) at Aberdeen, Maryland, continued in-house efforts to determine the terminal aim points

⁶⁸Hist Repts, REDEYE PM, FY 1969, pp. 13-14; FY 1970, pp. 11-12. Hist Div File.

~~CONFIDENTIAL~~

UNCLASSIFIED

~~UNCLASSIFIED~~

~~CONFIDENTIAL~~

of the PbSe seeker in the air-to-ground role. Although the feasibility of the helicopter RAM system was established, AMSAA recommended that it not be used in the configuration evaluated and that further studies be conducted of a modified seeker. These studies were not pursued, however, and the program was eventually terminated.⁶⁹

The Navy REDEYE Program

(U) The objective of the Navy's REDEYE program was to qualify the system for use as small craft armament. Phase I, conducted in October 1965, consisted of tracking tests on an 85-foot patrol launch boat to demonstrate the ability of the operator and weapon to track a target in the at-sea environment. Phase II, completed in August 1966, included eight Block II missile firings at sea from an 85-foot aircraft search and rescue boat. Phase III, finished in 1967, consisted of additional tracking tests with the Block II and III weapons, 28 Block II missile firings, and Hazards of Electromagnetic Radiation to Ordnance (HERO) tests. Although the flight tests were highly successful, they disclosed two problem areas which required further study: the Block II weapon failed to pass the HERO tests, and acquisition discrimination was difficult in the high noise environment of small boats.

(U) During the fourth and final phase, initiated in September 1968, the weapon's sight was modified to make it compatible with a Navy gunner's helmet and earphone set, and electromagnetic radiation protection was added to the weapon circuitry to make it safe in the shipboard environment. The modified sight design successfully passed shipboard tracking tests in November 1968. Electromagnetic-radiation-protected weapons proved satisfactory in HERO

⁶⁹(1) *Ibid.*, FY 1969, pp. 14-15; FY 1970, p. 12. (2) AMSA Tech Rept No. 47, Dec 70, subj: Eval of the Hel REDEYE Msl. ADSIMO File. (3) Intvw, M. T. Cagle w James A. Dailey, ADSIMO, 15 Aug 73.

~~CONFIDENTIAL~~

UNCLASSIFIED

tests in February and March 1969, and four missiles were fired from shipboard in April 1969. The Navy concluded its program on 1 August 1969 with delivery of a technical data package describing the Navy weapon. The successful completion of this program qualified the REDEYE for Navy use; however, there was no firm requirement for procurement of the system.⁷⁰

⁷⁰Hist Repts, REDEYE PM, FY 1969, p. 15; FY 1970, p. 13. Hist Div File.

~~UNCLASSIFIED~~

CHAPTER VII

TRAINING EQUIPMENT (U)

(U) Recognizing that the cost of ammunition and targets would seriously curtail live firings as a normal method of training the large number of REDEYE gunners expected, the user established a requirement for synthetic training devices and simulators. The original statement of requirement, approved by CONARC and OCRD in late 1958, called for three classes of ammunition (inert rounds for loading and handling practice; spotting rounds without warhead for training firing missions; and warhead rounds for service practice), along with appropriate tracking evaluation and training equipment. The service schools and other agencies training operating personnel in the use of the weapon system were to be provided with an electronic simulator to aid in training and testing weapon crews in target detection and acquisition, track, and destruction, and visual aids to explain system operation, tactical employment, and maintenance and safety procedures.¹

(U) Military characteristics for the 3-G-84 simulator were published in May 1960 and amended in July and December 1960. These original MC's were modified and replaced by a new statement issued by the Naval Training Device Center (NTDC) on 30 June 1962. Three months later, MICOM reported that no contractor proposal provided reasonable assurance that the modified MC's for the 3-G-84 trainer could be met. Consequently, the Army Air Defense School, on behalf of CONARC, prepared a set of revised MC's in a Small Development Requirement (SDR) format. The SDR for the

¹ Stmt of Rqrmt for Tng Aids for a Man-Transportable ADGM Sys. Atchd as incl to OTCM 37000, 19 Feb 59. RSIC.

REDEYE trainer, approved by OCRD on 20 November 1963, called for a full-scale synthesized weapon, similar in weight, configuration, center of gravity, handling, and operational characteristics to that of the tactical weapon. It gave the developer the choice of fulfilling the trainer requirements with either one or two devices, whichever was more economical. Subsequently, it was decided that the requirement could be met most economically by developing two independent devices: a field handling trainer and an electronic (tracking head) trainer.² The Army Missile Command had development responsibility for these items.³

(U) The results of human engineering studies showed that, to become proficient, a REDEYE operator should practice against real targets that were prohibitively expensive. Accordingly, an SDR was established, in May 1965, for a moving target simulator to provide REDEYE gunners simultaneous training in detecting and identifying aircraft and operating the weapon. Planned for installation in selected Army training centers, these simulators were to be used in conjunction with the tracking head trainers.⁴

The M46 Series Field Handling Trainer

(U) The M46 series field handling trainer, developed by Honeywell, Inc., was a rugged, inexpensive device for use in developing skills of weapon handling, sequential operational functions, and firing. Although the trainer could not track targets, it had switches and triggers that simulated those on the tactical system. As originally designed, it had a dual

²(1) Ltr, CG, CDC, to Distr, 4 Dec 63, subj: DA Apprd SDR for REDEYE Tnr, w incl. Atchd as incl to AMCTCM 3971, 16 Dec 65. RSIC. (2) AMCTCM 5001, Dec 66. RSIC.

³Ltr, CG, AMC, to CG, MICOM, *et al.*, 21 Jan 64, subj: DA Apprd SDR for REDEYE Tnr. Atchd to AMCTCM 3971, 16 Dec 65. RSIC.

⁴AMC TIR 21.1.6.1(2), Dec 66, p. 14. RSIC.

~~UNCLASSIFIED~~

~~CONFIDENTIAL~~

function. With the dummy rocket motor, the trainer was a ballasted weapon for familiarization and field handling exercises. When the separately issued XM-111 ejector motor was used, the XM-28 simulated missile was ejected from the XM-156 fiberglass launcher to simulate the eject phase for practice purposes. Because of its negligible training value, the eject feature was later dropped in favor of a simpler, cheaper device. The no-eject trainer thus adopted was an inert round that matched the weight and balance of the actual weapon. It employed either a ballasted, used launcher or a new launcher less unneeded electronic components.

(U) Design and development of the XM-46 trainer commenced in June 1964. An experimental model of the trainer was demonstrated during the Design Characteristics Review held at Honeywell, Inc., West Covina, California, on 3 December 1964. Preliminary testing of the trainer began later that month. Since engineering tests of the complete REDEYE weapon system provided sufficient data to assure that the use of the XM-46 was a very low risk approach, engineering tests of the trainer were waived. The Army Test & Evaluation Command (TECOM) completed service tests of the trainer in June 1966, and concluded that the item was ready for classification as Standard A. The Army Materiel Command, on 21 April 1966, had requested approval of an LP classification for the XM-46/XM-46E1 trainer; however, in view of the TECOM service test results and recommendations, OCRD, on 24 June 1966, approved classification of the trainer as Standard A. The M46 (XM-46) was the telescopic sight configuration, while the M46A1 (XM-46E1) and M46A2 (XM-46E2) were the open sight or Block II/III configuration. The standard M46A2 (XM-46E2) used a manufactured ballasted battery rather than an expended or rejected tactical battery. RDTE funding for the trainer totaled \$190,239.

☞ The initial production contract for the M46 trainer was

~~CONFIDENTIAL~~

UNCLASSIFIED

UNCLASSIFIED

~~CONFIDENTIAL~~

awarded to General Dynamics in January 1967. Industrial deliveries began in June 1967 and continued into January 1968, with a total of 2,025 units produced (165 Block I; 1,860 Block III). Of these, 643 were allocated to the Marine Corps and 1,382 to Army units. The basic allocation to tactical units was one trainer per REDEYE team. The replacement factor was established as 1 percent per year.⁵ Table 6 shows the actual distribution for FY's 1969 and 1970, and the projected distribution for the FY 1971-76 period.

TABLE 6--(C) Principal Item Distribution Plan - Guided Missile Intercept-Aerial Trainer, M46, M46A1, and M46A2 (U)

<u>Claimant</u>	<u>FY 1969 Actual</u>	<u>FY 1970 Actual</u>	<u>FY 1971-76 Planned</u>
U.S. Army, Europe.....	375	379	356
U.S. Army, Pacific (Korea)....	113	113	113
U.S. Army, Pacific (Hawaii)....	0	12	16
CONARC (CONUS - Strategic Army Forces--STRAF).....	337	343	358
CONARC (SEA).....	304	281	281
U.S. Army Pacific (SEA).....	83	83	83
U.S. Army, Alaska.....	43	38	38
U.S. Army, Southern Command....	0	17	17
Production Assurance Test.....	1	0	0
CONUS Schools.....	41	35	32
Maintenance Evaluation.....	2	1	1
REDEYE Project Manager.....	0	2	2
Depot Storage.....	35	19	0
Potential Excess.....	48	39	0
Washouts.....	0	20	85
	<u>1382</u>	<u>1382</u>	<u>1382</u>

SOURCE: REDEYE PMP, 31 Mar 70, p. 56.

⁵(1) AMCTCM's 3085, 25 Mar 65; 3876, 18 Nov 65; 5001, Dec 66; & 6095, 6 Jun 68. RSIC. (2) Ltr, CG, AMC, to CRD, DA, 21 Apr 66, subj: GM Sys, Intcp-Aerial, Tng: XM46, XM46E1 - Clas as LP Type, w 1st Ind, CRD to CG, AMC, 24 Jun 66. Atchd as incl to AMCTCM 5001, Dec 66. RSIC. (3) Hist Rept, REDEYE PM, FY 1968, p. 9. Hist Div File. (4) REDEYE PMP, 31 Mar 70, pp. 2, 31, 42. File same.

~~CONFIDENTIAL~~

UNCLASSIFIED

INTERCEPT AERIAL TRAINER M46 AND M46A2
Block I PRODUCTION (M46)

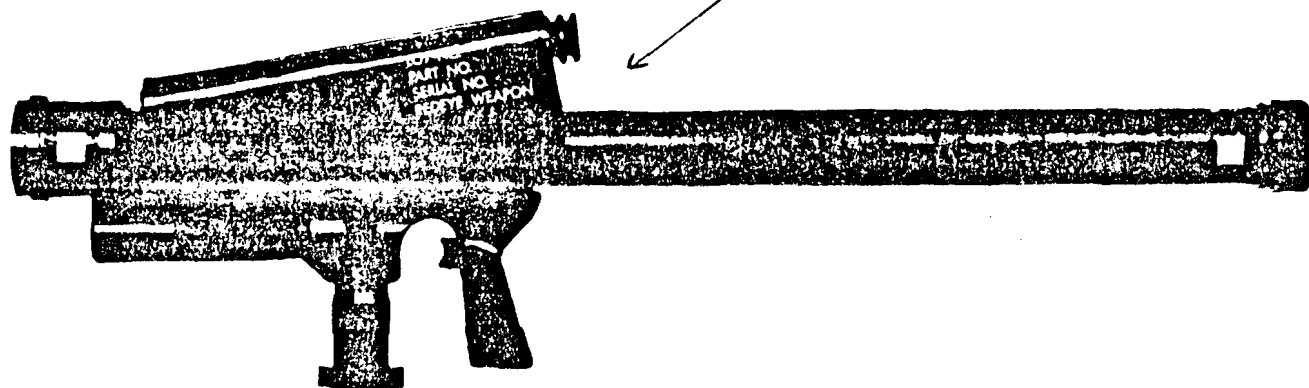

166

Block III PRODUCTION (M46A2)

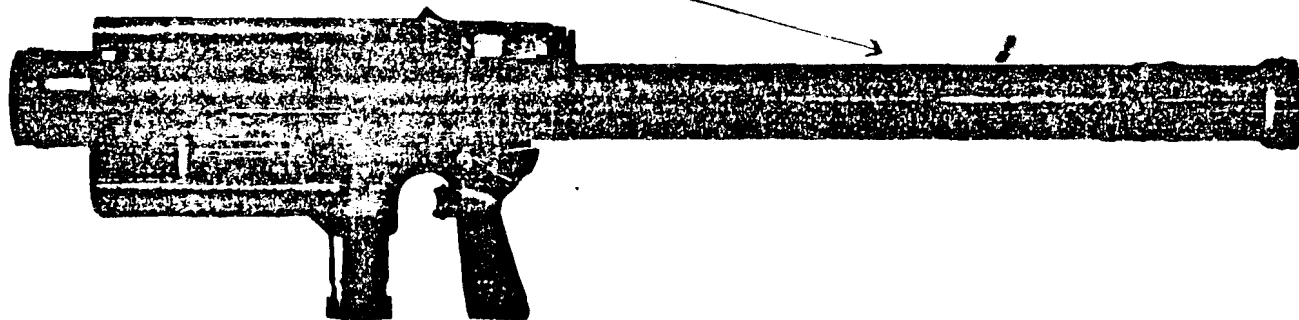

Electronic Trainers

(U) The trainers developed to fulfill the second part of the SDR were the XM-42 electronic trainer, which was never standardized; the XM-49 series tracking head trainer; and the improved XM-49 trainer, which was standardized as the M76 (XM-76) tracking head trainer.

XM-42 Electronic Trainer

(U) A contract for development of an electronic trainer was awarded to Honeywell, Inc., in March 1964. Similar in external appearance to the tactical Block I REDEYE, the XM-42 included the following modular components: main tube, gripstock, telescopic sight, infrared and optical subassembly, electronic section, power supply battery, indicator section, and simulated thermal battery. The trainer operated up to the point of launch against real or synthetic targets, in a manner simulating the real weapon. It thus provided the gunner training on all the sequential steps of an engagement and indicated to the instructor any errors committed.

(U) Tests of the breadboard operational unit were completed in September 1964. This was followed by tests of the full-scale experimental model, which was demonstrated during the Design Characteristics Review held on 3 December 1964. Engineering evaluation of the trainer was completed in January 1965, and the necessary design changes were incorporated in the development model.⁶ In order to provide the required trainers for resident training by July 1966, OCRD, on 19 January 1966, approved the classification of the XM-42 as LP for procurement of 20 trainers.⁷

⁶ AMCTCM's 4356, 27 Apr 66; 5685, 14 Dec 67. RSIC.

⁷ 1st Ind, CRD, DA, to CG, AMC, 19 Jan 66, on Ltr, CG, AMC, to CRD, 11 Jan 66, subj: GM Sys, Intcp-Aerial Tng: XM42 (REDEYE) - Clas as LP Type. Atchd as incl to AMCTCM 4356, 27 Apr 66. RSIC.

(U) Service tests of the XM-42 (Block I) trainer were conducted at Fort Benning, Georgia, and Fort Knox, Kentucky, concurrently with the REDEYE weapon system service tests at those sites. The results of these tests, completed in August 1966, indicated that the XM-42 electronic trainer would not be suitable for use in Army schools for initial REDEYE training, nor would it be satisfactory as a unit training device for deployed REDEYE teams. Tracking capabilities of the trainer were unsatisfactory because of its poor background rejection characteristics. In addition, the slow response of the trainer to mechanical orders of the gunners adversely affected the utility of the item as a device for training or maintaining the proficiency of REDEYE gunners.⁸

(U) During a special in-process review held in Washington on 28 September 1966, AMC proposed that development and engineering of the Block II XM-42 trainer, with a cooled IR detector cell, be continued in an effort to make the item suitable for training use. However, ACSFOR directed that no more money be spent on the development or procurement of the XM-42, except that necessary to support the moving target simulator development program. Although CONARC had previously recommended that the XM-42 not be procured for training, the Army Air Defense Center still wanted to use the XM-42's for gunner training until such time as sufficient XM-49 tracking head trainers were available. It was decided that, for the time being, one of the 20 LP devices would be allocated to the moving target simulator program and the other 19 to the Army Air Defense Center at Fort Bliss, Texas.⁹

⁸ (1) Ltr, CG, TECOM, to CG, MICOM, 3 Aug 66, subj: Ltr Rept of Svc Test of the XM-42 REDEYE Electronic Tnr, USATECOM Proj No. 3-4-0202-09 (GM-1564) (2) DA Msg 768621, ACSFOR to CG, AMC, 13 Sep 66. Both atchd as incls to AMCTCM 7061, Aug 69. RSIC.

⁹ (1) DA Msg 768621, *op. cit.* (2) Mins & Results of REDEYE Tng Device Sp IPR. Atchd to AMCTCM 5387, 20 Jul 67. RSIC.

(U) Development of the XM-42 electronic trainer was later terminated in favor of the XM-49 tracking head trainer.¹⁰ The XM-42 was reclassified from LP to obsolete in July 1970, and the 20 trainers produced were disposed of in accordance with AR 755-1.¹¹

Interim XM-49 Tracking Head Trainers

(U) During development of the REDEYE weapon system, General Dynamics determined that a device composed of standard components less explosive hardware would be of significant benefit for test purposes. Several of these devices were fabricated and used in conducting tracking tests, correlation of infrared data, and acquisition capability tests against various targets. Immediately, the potential of the device as an initial training aid to weapon gunners was recognized, and the training agencies established requirements for such a trainer. Designated as the XM-49 Tracking Head Trainer (THT), it was to provide the REDEYE gunners with an inert weapon capable of acquiring and tracking targets, providing a time delay to simulate the weapon operating time, and providing the audio/visual indications incorporated in the tactical weapon. The trainer would consist of the tactical REDEYE round less the following items: control section, missile and launcher batteries, fuze and warhead, rocket motor, tail assembly, and aft end cap. Electronic components would be included only to the extent required to cause the THT to acquire and track a live target in the same manner as the tactical weapon, and to provide the operator with the same audio/visual indications during the engagement as the tactical weapon.¹²

¹⁰ AMCTCM 5685, 14 Dec 67. RSIC.

¹¹ AMCTCM's 7061, Aug 69; 7900, 28 Jul 70. RSIC.

¹² AMCTCM 4675, 21 Jul 66, w incls: 1st Ind, OCRD, DA, to CG, AMC, 12 Mar 66, on Ltr, CG, AMC, to OCRD, undtd, subj: GM Sys, Intcp-Aerial, Tng: Tracking Head, XM49 (REDEYE) - Clas as LP Type. RSIC.

(U) The Chief of Research & Development, on 12 March 1966, approved classification of the XM-49 THT as LP and authorized the procurement of not more than 13 units.¹³ The Army Missile Command let a contract to General Dynamics for 10 of the trainers, and deliveries began in July 1966. As a result of the decision, in September 1966, to cancel the XM-42 program, the XM-49 became the prime electronic trainer, and full-scale development of the improved XM-49E3 trainer was initiated. To meet interim training requirements pending availability of the improved XM-49 trainer, OCRD, in October 1966, extended the LP authority by 58 units.¹⁴

(U) All told, MICOM purchased 76 of the interim XM-49 trainers. Included in these were 19 of the XM-49's, with the telescopic sight; 49 XM-49E1's, which had an open sight instead of the telescope; and 8 XM-49E2's, which contained Block III electronics, a gas coolant supply, and the open sight. Of the 76 trainers produced, 70 were under DA control, 8 of them being GFE for the moving target simulator contract. The remaining six were distributed among the U. S. Marine Corps (2), U. S. Air Force (2), Australia (1), and Sweden (1).¹⁵ The interim XM-49 tracking head trainer was reclassified from LP to obsolete in July 1970, following delivery of the improved XM-49E3 (M76) training set.¹⁶

The Standard M76 (XM-49E3) Training Set

(U) Developed during the FY 1967-68 period at a cost of \$535,360, the M76 (XM-76) training set consisted of the XM-49E3

¹³ *Ibid.*

¹⁴ (1) 1st Ind, OCRD to CG, AMC, 25 Oct 66, on Ltr, CG, AMC, to OCRD, 18 Oct 66, subj: XM-49 THT (REDEYE) - Addl LP. Recorded in AMCTCM 5207, 20 Apr 67. RSIC. (2) Hist Repts, REDEYE PM, FY 1966, pp. 13-14; FY 1967, p. 8. Hist Div File.

¹⁵ (1) *Ibid.*, FY 1967, p. 8. (2) AMCTCM's 5781, 25 Jan 68; 6258, 8 Aug 68. RSIC.

¹⁶ AMCTCM 7899, 28 Jul 70. RSIC.

INTERCEPT AERIAL TRAINER XM49

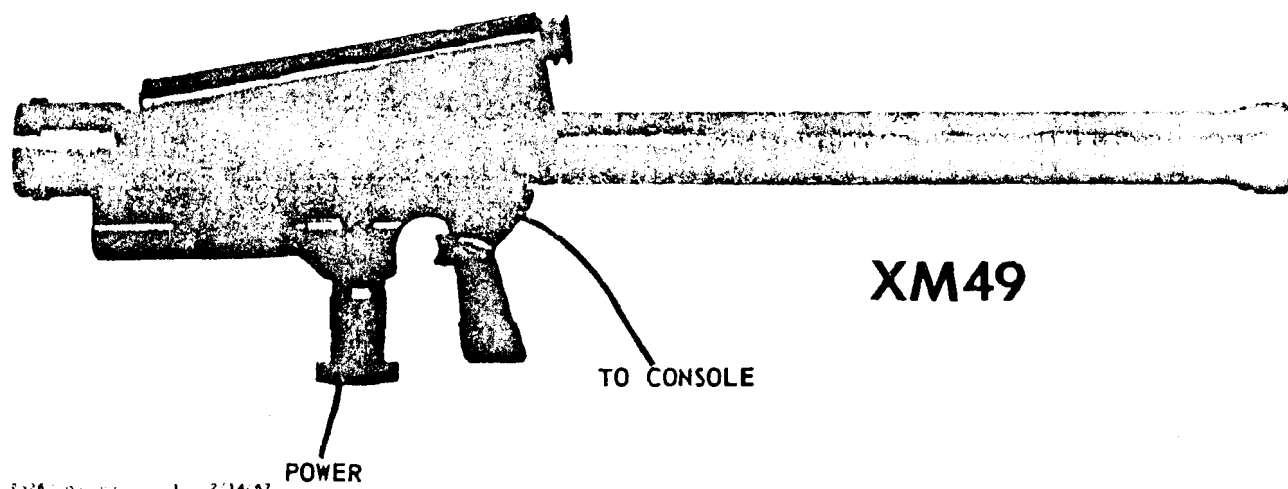

XM49

171

7-226-10-10-1 2/14/67

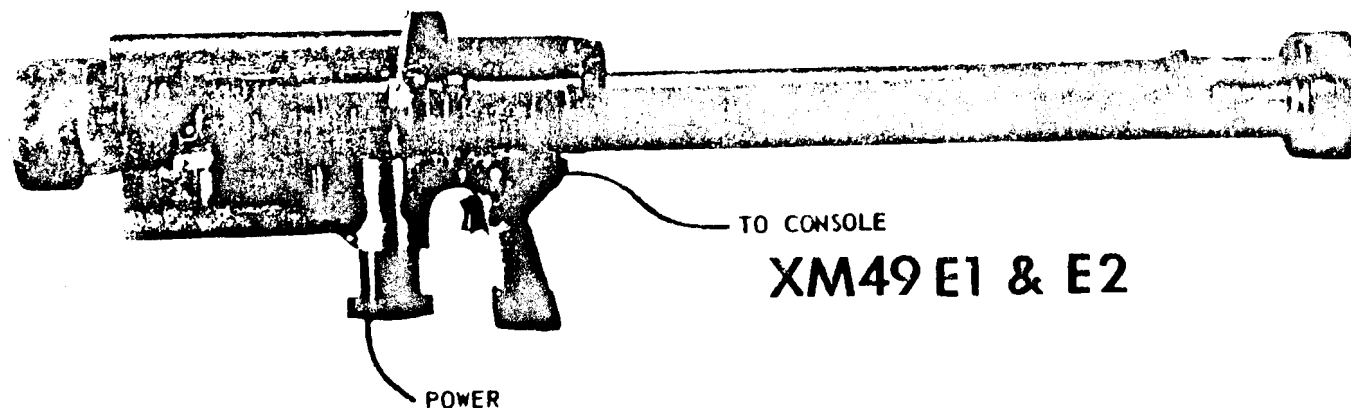

XM49 E1 & E2

7-226-10-10-1 2/14/67

tracking head trainer with an operational seeker and a closed-loop cryogenic cooling system, four rechargeable batteries, and a battery charger, all packaged in a modified XM-571 MONOPAK shipping and storage container. The trainer featured three major improvements over the interim XM-49 series: (1) it was a self-contained unit and, therefore, more closely simulated the tactical weapon; (2) it provided a performance indicator, which allowed the instructor to evaluate the trainee's progress; and (3) it eliminated the need for expensive and bulky ancillary equipment required by the interim trainers.¹⁷

(U) On 18 March 1968, ACSFOR approved the classification of the trainer as LP for procurement of 558 sets, including three for preproduction testing. Of the 555 production sets, 427 would be allocated to the Army, 70 to the U. S. Marine Corps, and 58 to foreign military sales. Later in March, General Dynamics received a contract for production of 497 trainers for the Army and Marine Corps. The other 58 trainers (45 for Sweden and 13 for Australia) were later placed under contract as customer funds became available.¹⁸

(U) Delivery of the FY 1968 production units began in April 1969 and continued into February 1970. Engineering and service tests, using the preproduction trainers, commenced in November 1968 and ended in August 1969, at which time the XM-76 training set was certified as suitable for troop use. Support maintenance training on the XM-76 trainer began at the Army Missile & Munitions Center & School, Redstone Arsenal, Alabama, in July

¹⁷ AMCTCM's 5781, 25 Jan 68; 6258, 8 Aug 68; & 8011, 22 Sep 70, w incls. RSIC.

¹⁸ (1) Hist Rept, REDEYE PM, FY 1970, pp. 10-11. Hist Div File.
(2) AMCTCM 6258, 8 Aug 68, w incl: 1st Ind, ACSFOR to CG, AMC, 18 Mar 68, on Ltr, CG, AMC, to ACSFOR, 27 Dec 67, subj: Req for TCLAS of LP for the REDEYE THT Sys. RSIC.

1969, and the first REDEYE unit was equipped with the trainer in November.¹⁹ The M76 (XM-76) training set was reclassified from LP to Standard A on 25 June 1970.²⁰

(U) In 1972-73, 57 additional M76 training sets were placed under contract, increasing the foreign military sales from 58 to 115 and the total procurement from 555 to 612. Distribution of the trainers was as follows:

U. S. Army	427
U. S. Marine Corps	70
Sweden	45
Australia	13
Denmark	28*
Federal Republic of Germany	29*
	<u>612</u>

*To be delivered in FY 1974.

As of 30 June 1973, 63 of the Army trainers were consigned to the various Army training schools and centers; 252 (including 19 maintenance floats) were in the hands of REDEYE teams at tactical sites; 36 were consigned to Army Reserve and National Guard units; 17 were out on loan; 1 was temporarily authorized the Teledyne Corporation; 7 were located at MICOM; 6 were depot maintenance floats; and 45 were in depot storage.²¹

¹⁹ (1) REDEYE PMP, 31 Mar 70, p. 31. Hist Div File. (2) AMCTCM 8011, 22 Sep 70, w incl: Ltr, CG, TECOM, to REDEYE PM, 4 Aug 68, subj: Final Rept, Svc Test (Temperate & Arctic Zone Phase) of GM Sys, Intcp-Aerial, REDEYE Tng Set, XM-76 (XM49E3 REDEYE THT), USATECOM Proj No. 3-7-0202-37/49. RSIC.

²⁰ 1st Ind, ACSFOR to CG, AMC, 25 Jun 70, on Ltr, CG, AMC, to ACSFOR, 3 Apr 70, subj: Tng Set, GM, M76 (REDEYE) Reclas from LP to STD A, Proj 1X279191D686. Atchd as incl to AMCTCM 8011, 22 Sep 70. RSIC.

²¹ (1) ADSIMO Rept, REDEYE Distr Planning Info, 30 Jun 73, p. 10. (2) ADSIMO Rept, REDEYE Wpn Sys Spt Items, 28 Jun 73. Both in Hist Div File.

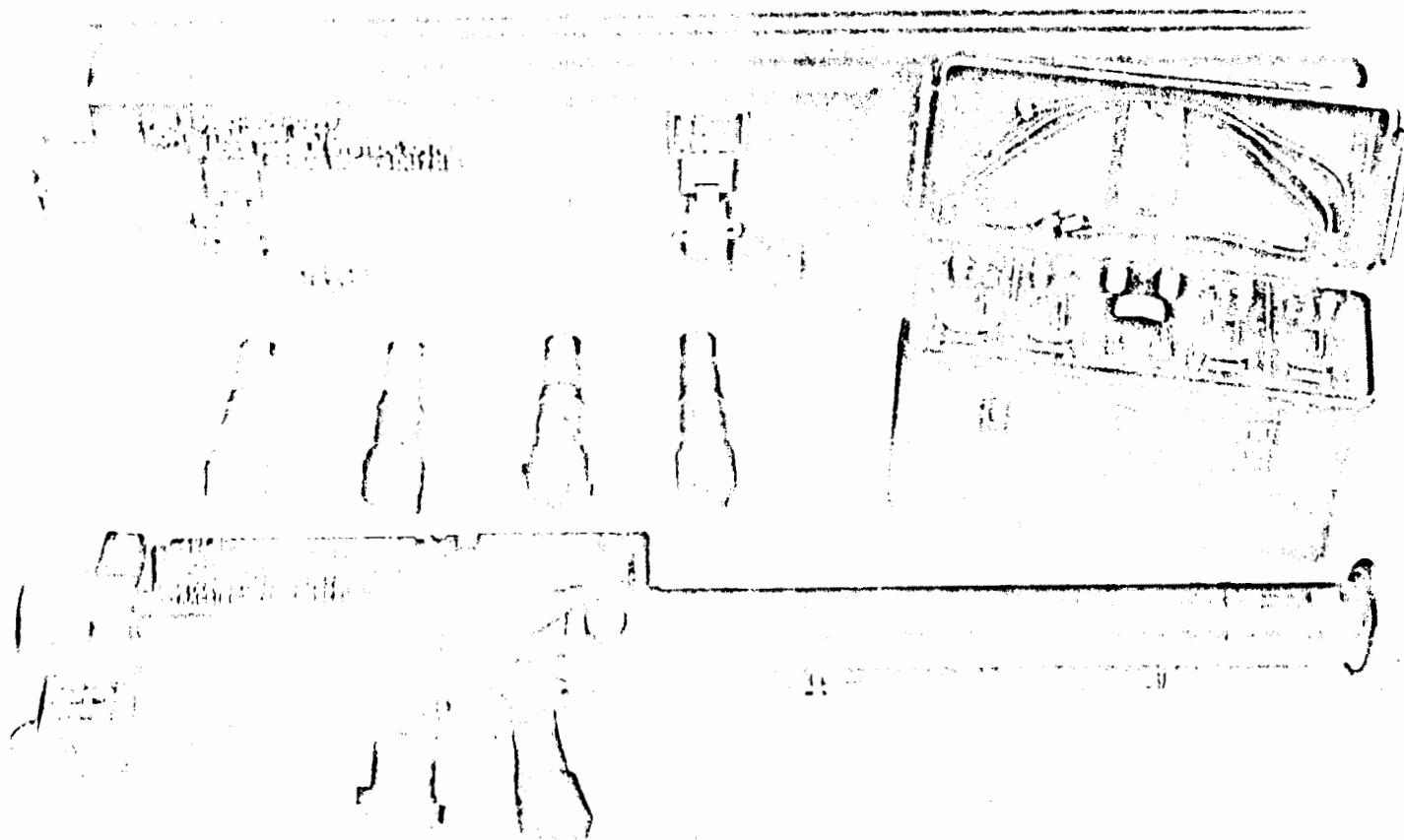

M76 (XM-76) Training Set

M87 Moving Target Simulator

(U) The Moving Target Simulator (MTS) was developed to provide effective, economical training for REDEYE gunners at Army training schools and centers, at oversea commands, and at CONUS installations where active Army divisions were located. Under the SDR approved on 20 May 1965, the MTS was to provide a considerable variety of typical aircraft types and trajectories on a repetitive and continuous basis for developing REDEYE gunner proficiency in target acquisition, range assessment, target tracking, and lead angle and superelevation insertion. It was to consist of a wide angle lens to project color background on a quadrispherical screen, a programmed projector to superimpose moving targets on the background, and a spot projector coupled to the target projector to simulate infrared emission from the displayed target image.

(U) Since the XM-42 electronic trainer, which was initially planned for use with the MTS, was sensitive to reflected solar (infrared) energy, the SDR also specified that the target simulator must have the capability of simulating such infrared emission characteristics. This requirement was later dropped, however, when the XM-42 was replaced by the new XM-49 series tracking head trainer, which was not sensitive to reflected solar energy.²² Another change in the original SDR had to do with the requirement for a wide angle lens to project changeable background terrain and sky conditions in full color. Because of the complexity of such a system and the development cost and time factors

²²(1) AMCTCM 4038, 20 Jan 66, w incl: Ltr, CG, AMC, to Cdr, Army Part Group, NTDC, *et al.*, 25 Jun 65, subj: DA Apprd SDR for MTS for REDEYE Tnr, CSCRD-65, w incls. RSIC. (2) AMCTCM 7901, Jul 70, w incl: Ltr, CG, CDC, to Distr, 30 Jan 69, subj: Ch 1 to DA Apprd SDR for MTS for REDEYE Tnr, CSCRD-65. RSIC.

involved, painted (theatrical) background scenes that attached to the projection screen were substituted for the more elaborate wide angle background projector.²³

(U) The Army Participation Group, Naval Training Device Center, had responsibility for the design and development effort, and the REDEYE Project Manager was responsible for program management. The Naval Training Device Center (NTDC) awarded the R&D contract to Aircraft Armaments, Incorporated,* on 27 June 1966. Included in the initial contract, for about \$800,000, were two prototypes of the MTS. The design specifications called for a quadrispherical screen about 20 feet high and 40 feet in diameter, with the projection and instructor console and trainee's position located at the center focus of the screen. The target aircraft would be simulated using 16-mm. color motion pictures projected onto the screen by means of a gimballed mirror. The film would change the target aircraft aspect, and digital control data on magnetic striping on the motion picture film would cause the gimballed mirror to move the projected image through its flight path on the screen. An infrared signature would be projected coincident with the optical path of the target projector. The magnetic striping would contain the control data which would turn the infrared on and off, and would also show the instructor when the target was within the kinematic launch boundary of the REDEYE system.²⁴

(U) The MTS Design Characteristics IPR was held on 21 March 1968 at AMC Headquarters, following a system demonstration, on 20

* Later renamed and hereafter referred to as the AAI Corporation.

²³(1) Ltr, REDEYE PM to CG, AMC, 24 Dec 68, subj: REDEYE MTS Background Projection Sys. Atchd as incl to Ltr, Dep REDEYE PM to CG, AMC, 25 Feb 70, subj: Req for TCLAS of Adopted STD A for Tng Set, MTS: XM87. Hist Div File. (2) AMCTCM 8070, 20 Oct 70. RSIC.

²⁴Hist Repts, REDEYE PM, FY 1966 & 1967. Hist Div File.

March, at the AAI Corporation in Cockeysville, Maryland. All interested commands agreed that the design characteristics of the simulator were acceptable for fabrication of two prototypes for delivery to the Army, one of which would be made available for ET/ST.²⁵ The R&D acceptance tests commenced in July 1968 and continued into October 1968.²⁶ They were followed on 9 December 1968 by the Prototype System Characteristics IPR.²⁷ The MTS development program was completed in FY 1970 with FY 1969 funds, at a total cost of \$2,137,000.²⁸

(U) The first prototype MTS was shipped to Fort Bliss, Texas, in October 1968, for use in ET/ST. The second prototype was kept at the contractor's plant to facilitate checkout of engineering changes. The engineering and service tests began on 8 February 1969 and continued until 5 August 1969, after which equipment modifications were made to correct noted deficiencies. The Test & Evaluation Command completed a check test of these modifications on 26 November 1969, with no deficiencies noted.²⁹ TECOM concluded that the MTS could be operated and maintained safely and that it was suitable for Army use. The M87 (XM-87) MTS was classified as Standard A on 21 July 1970, following the Development Acceptance IPR in March.³⁰

²⁵AMCTCM 6264, 10 Jun 68. RSIC.

²⁶REDEYE PMP, 31 Mar 70, p. 32. Hist Div File.

²⁷AMCTCM 6850, May 69, w incls. RSIC.

²⁸AMCTCM 8070, 20 Oct 70. RSIC.

²⁹Hist Repts, REDEYE PM, FY 1969 & 1970. Hist Div File.

³⁰(1) Ltr, REDEYE PM to CG, AMC, *et al.*, 16 Apr 70, subj: Req for Apprl of Mins of Dev Acptn IPR, Tng Set MTS: XM87 (REDEYE). (2) Ltr, REDEYE PM to CG, AMC, 16 Apr 70, subj: Req for TCLAS of Adopted Category STD A for Tng Set MTS: XM87 (REDEYE). Both in Hist Div File. (3) AMCTCM 8070, 20 Oct 70, w incl: 1st Ind, ACSFOR to CG, AMC, 21 Jul 70, on Ltr, CG, AMC, to ACSFOR, 19 Jun 70, subj: TCLAS of Tng Set, MTS: M87 (REDEYE) as STD A - Proj 1X279191D686. RSIC.

(U) Although the SDR called for a total Army requirement of 17 training sets, initial FY 1970 procurement was limited to 5 systems—4 for the Army Air Defense Center, Fort Bliss, and 1 for CONARC, Fort Bragg, North Carolina. Subject to DA approval of a complete basis of issue plan, 10 M87 simulators were to be procured in FY 1972, and the 2 R&D prototype models were to be updated to the production configuration. The estimated unit cost of the M87 was \$380,000. The cost of an MTS building was estimated at \$224,000. Four M76 REDEYE trainers would be required with each M87 MTS.³¹

(U) On 22 July 1970, Contract DA-AH01-71-C-0031, for \$798,524,^{*} was awarded to the AAI Corporation for the production of five M87 training sets. At the same time, an engineering services contract (DA-AH01-71-C-0030) was signed for engineering on documentation and correction of the shortcomings discovered during the ET/ST program.³² In FY 1972, this contract was extended through 30 September 1973 to cover engineering on documentation and correction of shortcomings revealed during the initial production tests. As of 1 April 1973, the value of the engineering services contract was \$1,036,175.³³

(U) The second buy of the M87 MTS, in FY 1972, consisted of 8 sets, instead of the 10 originally planned, making a total procurement of 13 excluding the two R&D prototypes. On 31 January 1972, Progress Aerospace Enterprises, Inc., of Philadelphia, Pennsylvania, was awarded a \$1.5 million contract for the eight M87's.³⁴ Five of

* The value of the initial production contract as of 1 April 1973 was \$920,285. P&PD Rept, Contr Listings, 1 Apr 73, p. 20.

³¹ (1) *Ibid.* (2) Ltr, REDEYE PM to CG, CONARC, 29 Jan 71, subj: REDEYE MTS Buildings. Hist Div File.

³² Hist Rept, ADSIMO, FY 1971, p. 1. Hist Div File.

³³ (1) P&PD Rept, Contr Listings, 1 Apr 73, p. 19. (2) MICOM Hist Sum, FY 1972, p. 75. Both in Hist Div File.

³⁴ *Ibid.*

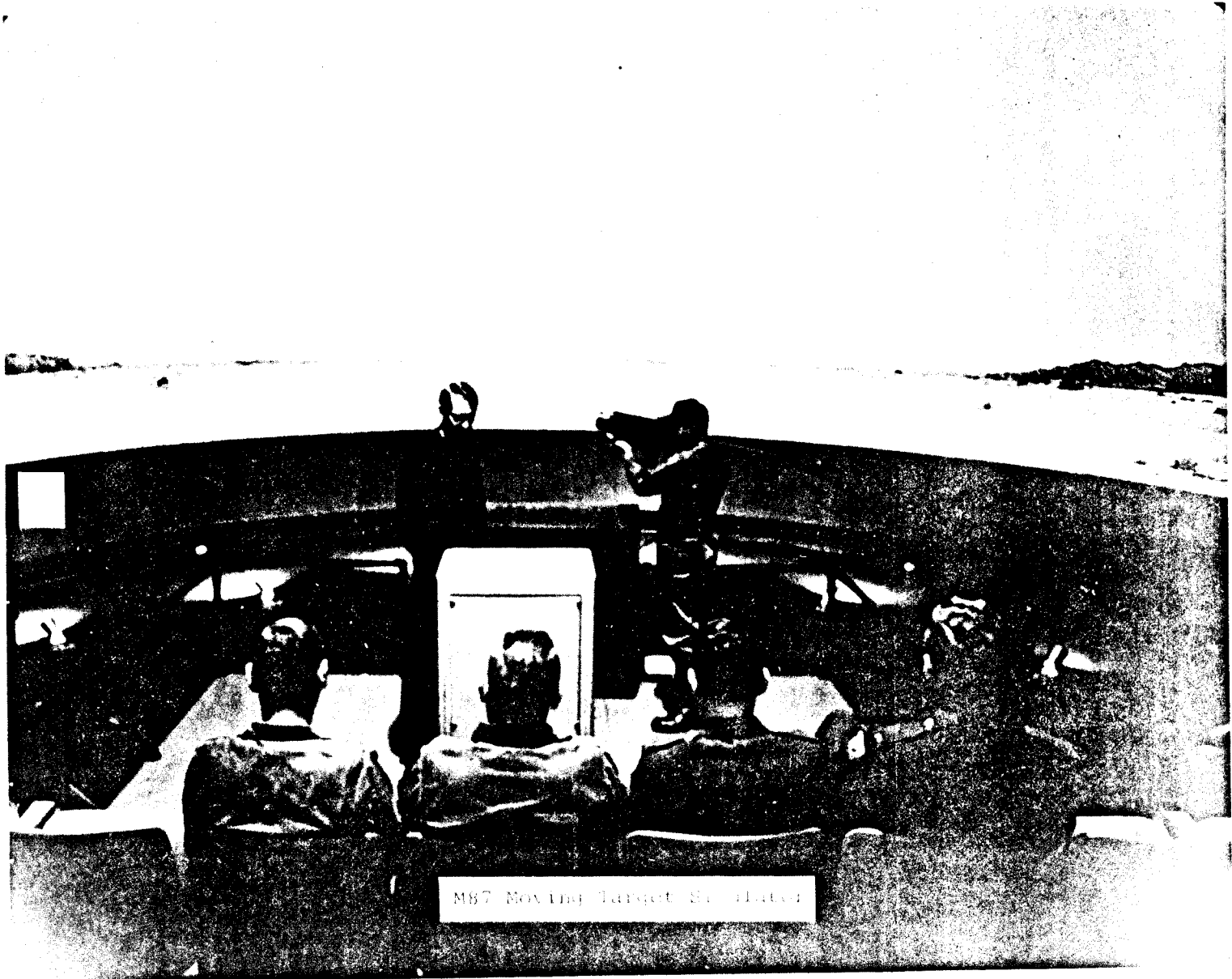

MB7 Nov 1961 Target St. Hater

these were allocated to Army oversea installations: three to Germany, one to Korea, and one to Hawaii. The remaining three sets were allocated to CONUS installations: Fort Riley, Kansas; Fort Hood, Texas; and Fort Carson, Colorado.³⁵

(U) Military Construction, Army (MCA) funds for construction of the four MTS buildings at Fort Bliss were made available in FY 1971, and the contract was awarded on 9 April. Funds for construction of the MTS building at Fort Bragg were deferred to FY 1972.³⁶ The first four moving target simulators became operational at the Army Air Defense Center, Fort Bliss, in January 1972. The MTS at Fort Bragg became operational on 26 July 1972.³⁷

(U) Contracts for construction of the eight remaining MTS buildings were awarded in FY 1973. Although none of these had been completed as of 30 June 1973, the latest MCA schedule indicated that the buildings would be available well in advance of the MTS deliveries (see Table 7).³⁸

³⁵ Ltr, REDEYE PM to CG, CONARC, 29 Jan 71, subj: REDEYE MTS Bldgs. Hist Div File.

³⁶ Hist Rept, ADSIMO, FY 1971, p. 2. Hist Div File.

³⁷ (1) MICOM Hist Sum, FY 1972, p. 76. (2) Hist Rept, ADSIMO, FY 1973. Hist Div File.

³⁸ (1) DF, Mgr, ADSIMO, to Cdr, MICOM, 15 Jun 73, subj: Weekly Significant Actv Rept for Week Ending 15 Jun 73. (2) ADSIMO Rept, REDEYE Distr Planning Info, 30 Jun 73, p. 11. Both in Hist Div File.

TABLE 7—(U) M87 Moving Target Simulator
 Revised Schedule as of 30 June 1973

<u>Location</u>	<u>Bldg Compl</u>	<u>*MTS Ship Date</u>	<u>*On Site Installation and Acceptance Tests</u>
Ft Hood, Texas	Aug 73	Oct 73	Nov 73 - Jan 74
Ft Carson, Colorado	Oct 73	Dec 73	Dec 73 - Jan 74
Ft Riley, Kansas	Dec 73	Jan 74	Jan - Feb 74
Schofield Bks, Hawaii	Aug 73	Dec 73	Feb - Apr 74
Tongduchon, Korea	Mar 74	Jan 74	Mar - May 74
Schwabach, Germany	Feb 74	Feb 74	Apr - Jun 74
Vilseck, Germany	Feb 74	Apr 74	Jun - Jul 74
Finthen, Germany	Mar 74	May 74	Jul - Aug 74

*A slippage of about 60 days possible.

SOURCE: ADSIMO Rept, REDEYE Distribution Planning Information,
 30 Jun 73, p. 11.

UNCLASSIFIED

~~CONFIDENTIAL~~

CHAPTER VIII

~~(S)~~ WEAPON SYSTEM DEPLOYMENT (U)

(U) The REDEYE weapon system was first deployed with Army ground forces in October 1967, some 6 years later than originally planned. It had no replacement weapon counterpart in the air defense arsenal, other than the outmoded World War II .50-caliber machine gun. Its introduction into the family of operational air defense weapons filled a longstanding, urgent requirement for a man-portable, shoulder-launched weapon to protect troops in the forward combat area against attack by low-flying, strafing planes and close-support aircraft.

Employment/Deployment Concepts

~~(S)~~ The REDEYE all-arms employment concept adopted by the Army envisioned a REDEYE team consisting of two gunners with a basic load of six missiles deployed with each company size unit in the forward combat area. However, to provide flexibility in deployment and to insure effective training, the team was organized into sections organic to selected battalion size units. The commander of the parent unit was responsible for the proficiency, training, deployment, and employment of the REDEYE teams and for their compliance with air defense standing operating procedures established by higher headquarters.

~~(S)~~ The Marine Corps philosophy of employment for the REDEYE differed somewhat from that of the Army. The infantry battalion offered built-in combat control through the Tactical Air Control Party (TACP), where information relative to friendly aircraft in the area was available and where organic radio communications

~~CONFIDENTIAL~~

UNCLASSIFIED

existed. Plans were to make REDEYE organic to the infantry battalion, which would incorporate the weapon in a TACP section with four forward air controllers attached to each rifle company.¹ The succeeding discussion deals only with Army employment of the system.

Employment Missions

(U) The basic mission of the REDEYE weapon system was to provide combat and selected combat support units with organic means of defense against low level attack, vertical envelopment, and aerial observation and surveillance. The offensive threat consisted of observation aircraft, helicopters, transports, and attack aircraft (jet and propeller), with speeds of from 0 to 600 knots. The basic REDEYE could engage targets up to about 439 knots.

(U) Normally, the REDEYE would be used to provide local air defense for small battalion or company size units in position or during movement. It would also provide perimeter defense around small vital areas, such as airfields or radar/missile sites, where no other means of air defense was available. It was not generally considered feasible to assign REDEYE the mission of defending large extended land areas. REDEYE teams, however, would force enemy aircraft to operate at higher speeds and altitudes, decreasing the attacker's effectiveness and increasing his vulnerability to other air defense weapons such as the HAWK and the NIKE HERCULES.

Organization

(U) The basic tactical organization consisted of gunner teams and section headquarters elements. Each team had a team leader and a gunner, each of whom was trained to operate as a gunner or

¹REDEYE PM₂P, 31 Mar 68, p. 3. Hist Div File.

REDEYE

TARGET TYPES

PROPELLER AIRCRAFT

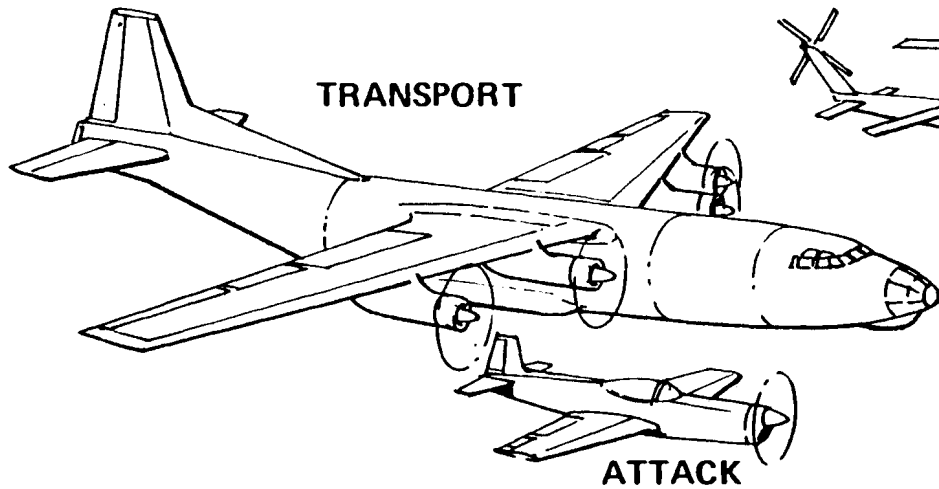

TEST DRONES

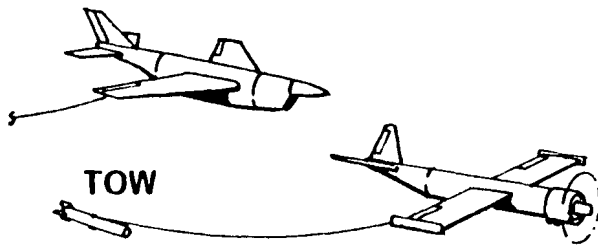

JET AIRCRAFT

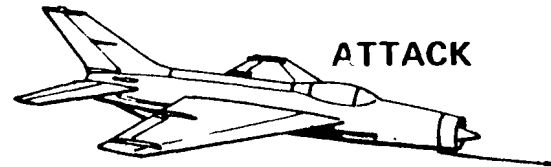

UNCLASSIFIED

~~CONFIDENTIAL~~

as an assistant for communications, spotting, and driving. During periods of intense activity, both could act as gunners to increase the rate of fire and to cover additional avenues of approach. Command of, and in most cases, operational control of the REDEYE teams was exercised by an air defense section headquarters at battalion level. This element generally consisted of a lieutenant, as section leader, a section sergeant, and a driver/radio telephone operator. Both the section leader and section sergeant were trained as gunners.

(S) The section headquarters element controlled from three to five REDEYE teams, the number varying with the different type battalion organizations. An average infantry battalion, for example, would have a control section at battalion headquarters and four gunner teams—one for each company. The number of teams allocated to a U. S. Army division varied with the specific makeup of the unit. The average force levels of Army Infantry, Armored, Mechanized, Airborne, and Airmobile Divisions ranged from 49 to 62 teams, depending upon their individual missions and the combat situation.²

(S) Since the REDEYE had no electronic equipment to perform the IFF function, control of the gunner teams would be accomplished by use of specific Standing Operating Procedures (SOP's) incorporating theatre, region, and sector air defense directives in regard to rules of engagement, weapon control status, hostile criteria, rules for target selection, and special flight information. The SOP had to be sufficiently comprehensive so that the gunner would know when he should or should not fire.³

² REDEYE Wpn Sys Sum, Jan 70. RHA Bx 13-291.

³ (1) *Ibid.* (2) REDEYE PM₂P, 31 Mar 68, p. 3. Hist Div File.
(3) *Also see* above, pp. 87, 127.

~~CONFIDENTIAL~~

UNCLASSIFIED

REDEYE

CHART 7

ORGANIZATION



181

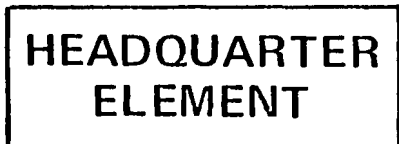

- 1 - LIEUTENANT (SECTION LEADER)
- 1 - SECTION SERGEANT
- 1 - PRIVATE FIRST CLASS
(RADIO/TELEPHONE OPERATOR)

*NUMBER WILL VARY

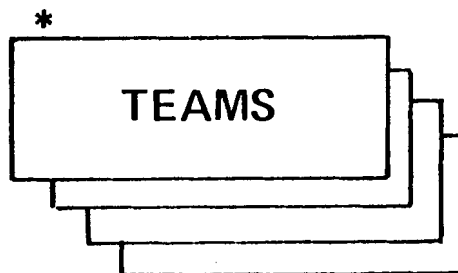

- *
1 - SERGEANT
(TEAM CHIEF)
- 1 - SPECIALIST/4
(GUNNER)

REDEYE

CHART 8

ALLOCATION OF REDEYE TEAMS TO U.S. ARMY DIVISION (U)

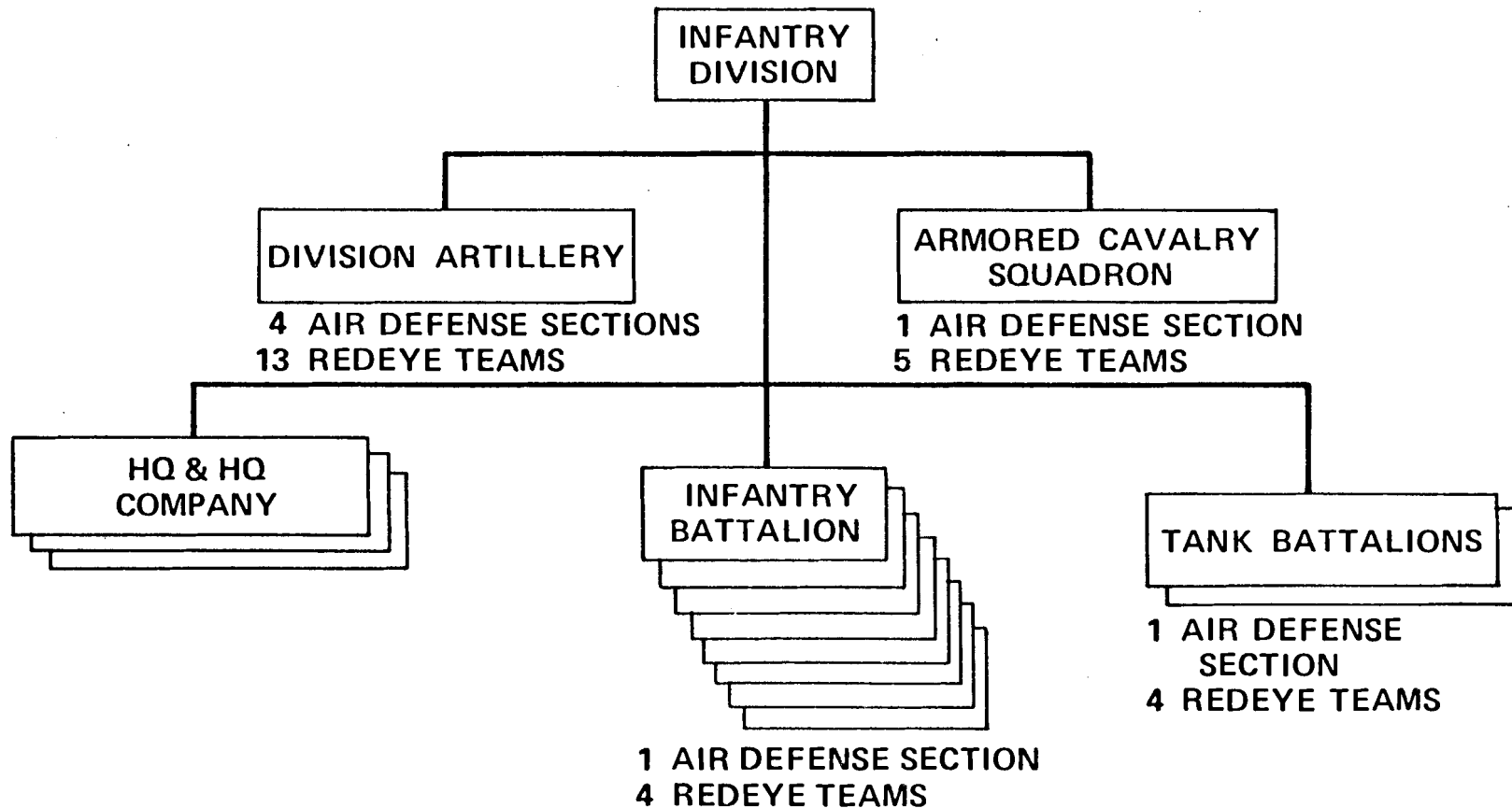

AVERAGE ALLOCATION - 60 TEAMS PER DIVISION

UNCLASSIFIED

CONFIDENTIAL

187

UNCLASSIFIED
CONFIDENTIAL

REDEYE

DIVISION DEPLOYMENT OVERVIEW (U) TYPICAL AREA DEFENSE

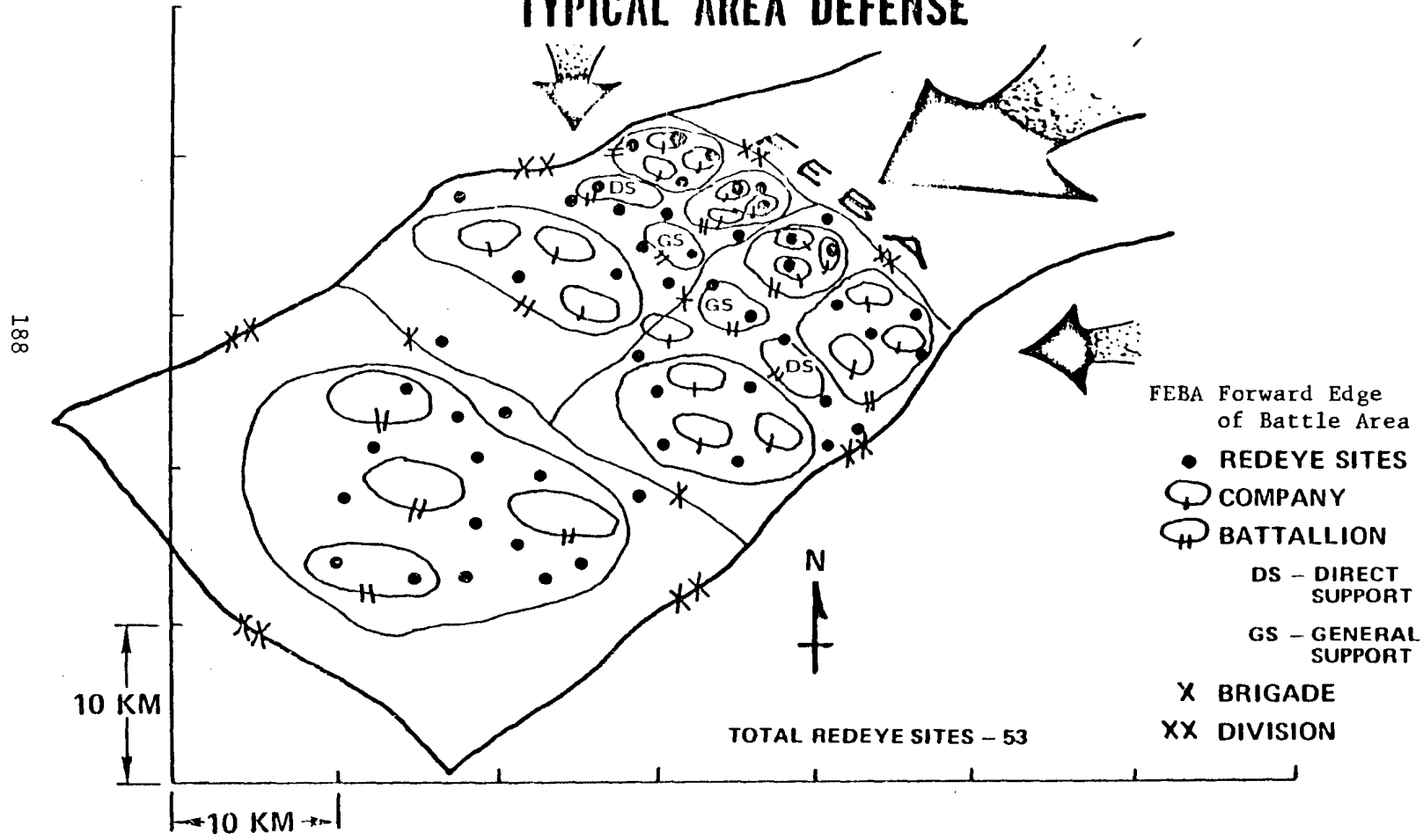

UNCLASSIFIED

CONFIDENTIAL

CONFIDENTIAL

UNCLASSIFIED

REDEYE

PROCUREMENT ITEMS (U) U.S. BASIS OF ISSUE

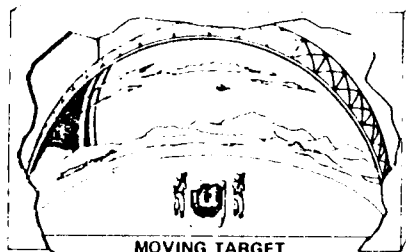

MOVING TARGET
SIMULATOR
(MINIMUM ONE PER SCHOOL,
WITH 4 XM76 TRAINING SETS)

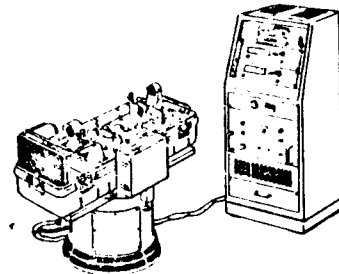

WEAPON SURVEILLANCE
TEST EQUIPMENT
(U.S. ARMY SURVEILLANCE PROGRAM)

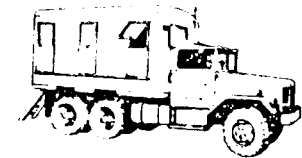

MAINTENANCE SHELTER
(ONE FOR EACH GENERAL SUPPORT/
DIRECT SUPPORT UNIT)

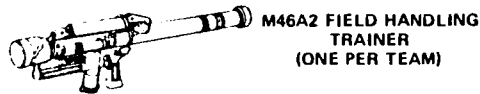

M46A2 FIELD HANDLING
TRAINER
(ONE PER TEAM)

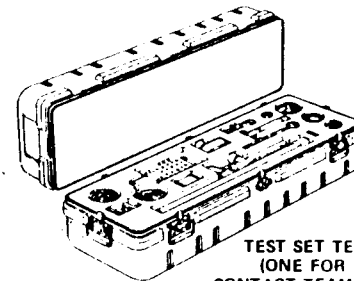

TEST SET TEST EQUIPMENT TS2554
(ONE FOR EACH GS/DS MOBILE
CONTACT TEAM OR MAINTENANCE UNIT)

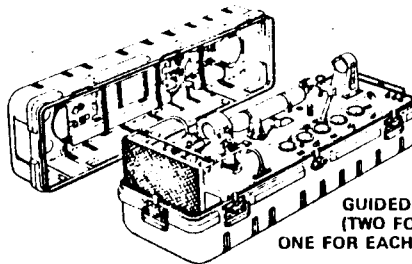

GUIDED MISSILE TEST SET AN/TSM-82
(TWO FOR EACH ASP AND DEPOT PLUS
ONE FOR EACH SELECTED POST, CAMP OR STATION)

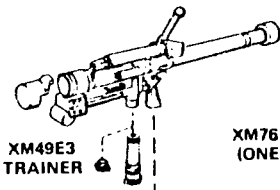

XM49E3
TRAINER (ONE PER SECTION)

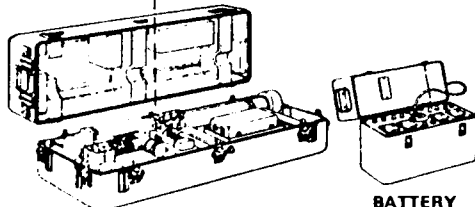

MONOPAK SHIPPING
& STORAGE CONTAINER

BATTERY
CHARGER

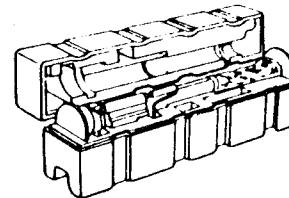

UNIPAK
(TWELVE WEAPONS PER TEAM)

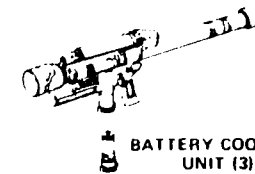

BATTERY COOLANT
UNIT (3)

F59842

189

UNCLASSIFIED

CONFIDENTIAL

CONFIDENTIAL

UNCLASSIFIED

Training Program

(U) New equipment training on the REDEYE weapon system began in September 1964. Key Instructor/Key Operation and Supervisory Personnel courses started in February 1966 and continued until July 1966. Resident training was initiated in January 1967. Troop (initial gunner) training began in February 1967 and was completed in September 1968.⁴

Gunner and Controller Training

(U) Battery E, 2d Air Defense Guided Missile Group, 1st Training Brigade of the Army Training Center at Fort Bliss, Texas, handled instruction and training for all REDEYE controller and gunnery students. The Headquarters Controller Section personnel received a 59-hour course in command, control, service support, and tactical operational procedures. The controller graduates were then phased into the gunnery course. Before actually firing the weapon at Orogrande Range near Fort Bliss, the controller and gunnery students received 92 hours of classroom instruction in aircraft detection and recognition; weapon/trainer operation; weapon system performance; safety and emergency procedures; target tracking and ranging; infrared acquisition; and firing techniques and procedures.

(U) The first troops trained from units in the field were members of the 101st Airborne Division, Fort Campbell, Kentucky. At the end of their classroom instruction, the students fired the REDEYE missile for the first time and achieved five direct hits out of six trials. The second group of gunners topped this, knocking down five out of five. These troop demonstrations, and others that followed, proved that selected men from the field

⁴(1) REDEYE PM₂P's, 31 Dec 67, p. 26, and 30 Sep 68, p. 33.
(2) REDEYE PMP, 31 Dec 69, p. 29. Hist Div File.

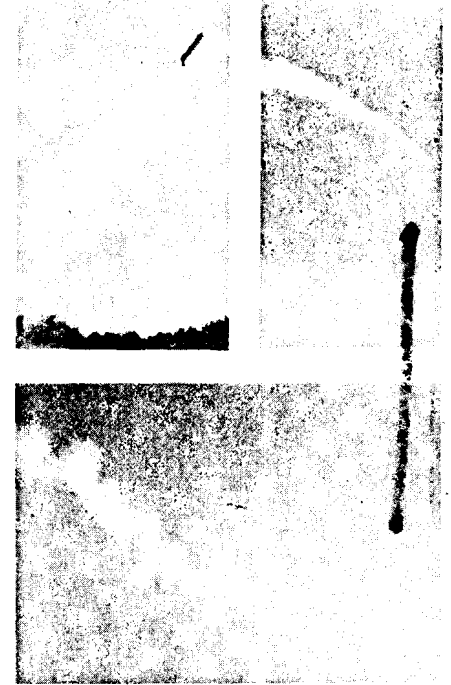
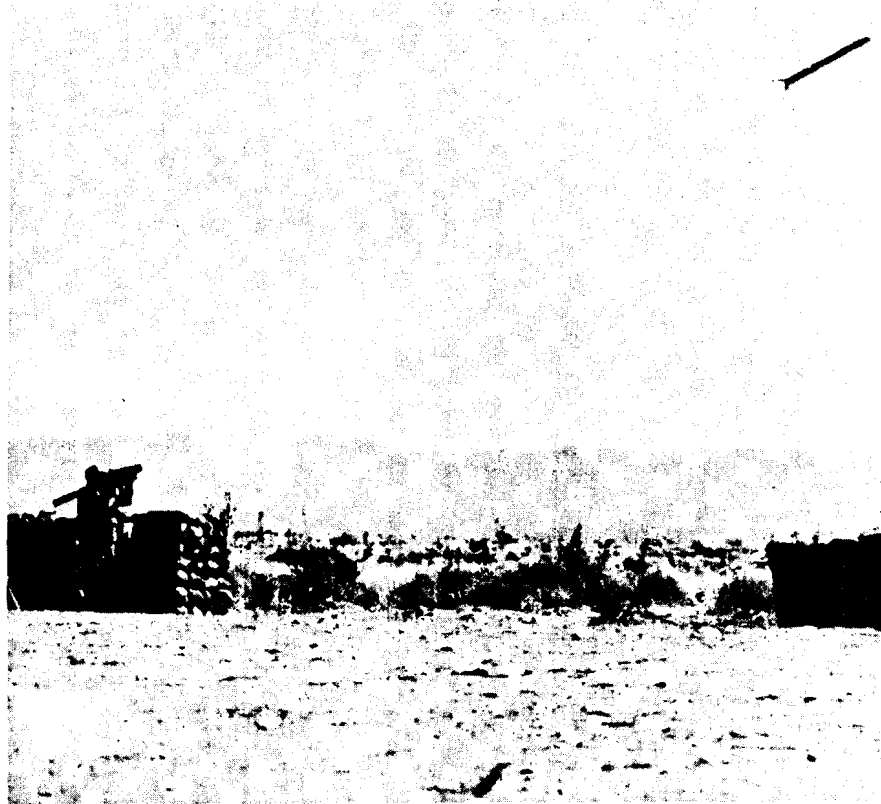

TROOP TRAINING TEST AT OROGRANDE RANGE—Preparing to fire the REDEYE missile, SSG Philip Williams moves up to the weapon with instructor SSG Robert Duncan (in white helmet). Sergeant Williams hefts the lightweight weapon, then begins tracking the radio-controlled aerial target, and a second before firing raises the launcher. The first stage sends the missile about 20 feet from the launcher, after which the sustainer motor propels the heat-seeking missile to the target. After impact, the remains of the target float to the ground. (Army Digest Photos by SFC Anthony Evanoski.)

~~UNCLASSIFIED~~

~~CONFIDENTIAL~~

could be trained in a short time to fire the REDEYE weapon safely and effectively.⁵

Maintenance Training

(U) Maintenance personnel slated for assignment to direct and general support units received maintenance training at the Army Missile & Munitions Center & School at Redstone Arsenal, Alabama. In addition to 392 hours of basic electronics training, the REDEYE maintenance course consisted of 180 hours of instruction on the following major subjects: REDEYE weapon system and round; the Guided Missile Test Set; the M76 training set; system operating procedures; quality control; missile electronics and logic circuits; safety and security; and shop practices and operations.⁶

Implementation of Army Deployment Plans

~~(S)~~ The technical problems and resultant schedule slippages experienced during the development and production programs⁷ delayed the initial operational availability of the REDEYE system by some 6 years—from 1961 to 1967. The first 25 sets of Block II weapons were initially scheduled for deployment to Southeast Asia (SEA); however, ACSFOR revised this plan and rescheduled deployment of the first REDEYE teams to the U. S. Army, Pacific (USARPAC) (Korea), instead of SEA.⁸ The realigned schedule, issued by ACSFOR on 21 June 1966, called for initial deployment of Block II systems to USARPAC (Korea) in the first quarter of FY 1967, followed by the distribution of Block III systems to the U. S. Army, Europe (USAREUR) in the second quarter of FY 1967; USCONARC (CONUS) in

⁵ (1) REDEYE Wpn Sys Sum, Jan 70. RHA Bx 13-291. (2) *Army Digest*, Jun 67, p. 48.

⁶ REDEYE Wpn Sys Sum, Jan 70. RHA Bx 13-291.

⁷ See chronological account in Chapters IV, V, and VI.

⁸ AMC Hist Sum, FY 1967, p. 175.

~~CONFIDENTIAL~~

UNCLASSIFIED

UNCLASSIFIED

~~CONFIDENTIAL~~

the fourth quarter of FY 1967; the U. S. Army, Alaska (USARAL) in the first quarter of FY 1968; and the U. S. Army Forces, Southern Command (USARSO) in the second quarter of FY 1968. Six months later, on 23 December 1966, ACSFOR again revised the deployment plan, as follows:⁹

	<u>Quarter</u>	<u>Fiscal Year</u>
USARPAC (Korea)	4th	1967
USAREUR	4th	1967
USCONARC (CONUS)	4th	1967
USARAL	3d	1968
USARSO	3d	1968
USARPAC (SEA)	3d	1968
USCONARC (RVN*)	4th	1968

*Republic of Vietnam

The team deployments scheduled for FY 1967 could not be met because of slippages in delivery of production end items, a shortage of repair parts, delays in receipt of shipping authority from the gaining commands, and a lack of stock funds for the assembly of repair parts at Tooele Army Depot. Since a minimum of 120 days would be required for all materiel to be assembled and shipped as a package, the plan for deployment of the Block II system to USARPAC (Korea) was extended from May 1967 to September 1967. Deployment of the Block III system to CONARC (CONUS), USAREUR, and USARAL was rescheduled for the second, third, and fourth quarters of FY 1968, respectively. Deployments to the last three commands were moved back to the first quarter of FY 1969.¹⁰

⁹ (1) DA Msg 770428, ACSFOR, DA, 21 Jun 66, subj: REDEYE Team Dplmt Scd. (2) DA Msg 794966, ACSFOR, DA, 23 Dec 66, subj: Revised REDEYE Dplmt Scd. Both cited in Hist Rept, REDEYE PM, FY 1967, p. 15.

¹⁰ (1) DA Msg 825411, ACSFOR, 27 Jul 67, subj: Revised REDEYE Team Dplmt Scd. Cited in Hist Rept, REDEYE PM, FY 1968, p. 16. (2) REDEYE PM2P's, 31 Mar 67, 30 Jun 67, & 30 Sep 67. Hist Div File. (3) DF, Cmt 4, S&MD to REDEYE PM, 29 May 67, subj: REDEYE Sys Dplmt to USARPAC (Korea). File same. (4) Also see above, pp. 138-40.

~~CONFIDENTIAL~~

UNCLASSIFIED

UNCLASSIFIED

~~CONFIDENTIAL~~

(S) Deployment of the REDEYE within the Army began in October 1967, when Block II systems and support items were delivered to USARPAC (Korea). These Block II systems were replaced with Block III tactical weapons early in FY 1969, and the supplanted weapons were returned to Fort Bliss for use in CONARC training programs.¹¹

(S) Block III weapons were deployed to Europe on schedule, in March 1968; however, the delivery of basic load weapons to other Army claimants was delayed. Under the revised schedule, issued by ACSFOR on 26 March 1968, the delivery of equipment for CONARC (CONUS) was extended from the second to the fourth quarter of FY 1968, and deployment of REDEYE teams to USARAL was set back from the fourth quarter of FY 1968 to the first quarter of FY 1969. The delivery of basic load weapons to USARAL actually began in the second quarter of FY 1969 and continued into the third quarter.¹²

(S) Deployment of the REDEYE to USARSO was extended from the first quarter of FY 1969 to the first quarter of FY 1970, because of a delay in completion of confirmatory tests and release of the equipment as suitable for troop use in the tropics. Personnel were deployed to the Southern Command in December 1968, and the delivery of basic load weapons was completed at the end of September 1969.¹³

(S) During FY 1970, the U. S. Army, Hawaii (USARHAW) was added to the REDEYE deployment plan, and basic load weapons and support equipment were delivered to accommodate one brigade. At the end of FY 1971, deployment of Army Acquisition Objective (AAO) weapons and ground support equipment was completed to USARPAC (Korea), USAREUR, USARAL, USARSO, and USARHAW. REDEYE ground support equipment and

¹¹ REDEYE PM₂P's, 31 Dec 67 & 30 Sep 68. Hist Div File.

¹² (1) *Ibid.*, 31 Dec 68. (2) REDEYE PMP, 30 Jun 69. Hist Div File.

¹³ (1) REDEYE PM₂P, 31 Dec 68. (2) REDEYE PMP's, 31 Mar 69, 30 Jun 69, & 30 Sep 69. Hist Div File.

~~CONFIDENTIAL~~

UNCLASSIFIED

trainers were issued to Fort Bliss, Fort Bragg, Fort Benning, Fort Campbell, Fort Carson, Fort Hood, Fort Riley, Fort Lewis, Fort Meade, Fort Sill, Fort Knox, and Redstone Arsenal for support of Strategic Army Forces (STRAF) and Reforger units in CONUS and CONARC service schools. REDEYE weapons programmed for CONUS and all items for Army units in SEA were held at the Tooele Army Depot.¹⁴ Requirements for the latter were later cancelled.

Each REDEYE team was deployed with a basic load of 6 weapons and had a total authorized load of 12 weapons with command stock. As of FY 1974, there were 563 gunner teams in the 5 Army commands with a total of 6,756 weapons, and 697 STRAF and reserve teams in CONUS with an allocation of 8,364 weapons. There were 180 weapons held for DA contingency in Korea, making a total AAO of 15,300. Distribution of the REDEYE weapon AAO and teams/section headquarters for FY 1974 is shown below.

<u>Location</u>	<u>Wpn AAO</u>	<u>No. of Teams</u>	<u>No. of Sec HQ</u>
USAREUR (Germany)	5,028	419	94
USARPAC (Korea)	696	58	13
USARHAW (Hawaii)	516	43	10
USARSO (Canal Zone)	228	19	4
USARAL (Alaska)	288	24	5
CONUS (STRAF)	6,096	508	118
CONUS (Reserve)	2,268	189*	42**
	<u>15,120</u>	<u>1,260</u>	<u>286</u>
DA Contingency - Korea	180		
	<u>15,300</u>		

*43 U. S. Army Reserve and 146 U. S. National Guard.

**11 U. S. Army Reserve and 31 U. S. National Guard.

The basic REDEYE weapon system was expected to remain in service until availability of the improved STINGER system. The

¹⁴ (1) Hist Rept, REDEYE PM, FY 1970, p. 15. (2) Hist Rept, ADSIMO, FY 1971, p. 6. (3) Ltr, REDEYE PM to CINCUSARPAC, 21 Jan 70, subj: Introduction of REDEYE to USARPAC, Hawaii. All in Hist Div File.

CONFIDENTIAL

By [Signature]

UNCLASSIFIED

~~CONFIDENTIAL~~

~~SECRET~~

latest plan called for deployment of the first STINGER teams early in FY 1978. The STINGER system would replace the basic REDEYE weapon on a one-for-one basis. The supplanted weapons would then be reassigned to CONUS (Reserve).¹⁵

Stratification of Army REDEYE Weapons

As of 30 June 1973, 3,565 of the REDEYE weapons acquired by the Army had been expended, leaving an inventory balance of 17,331. Of these, 7,828 were assigned to the 5 Army commands and 9,259 were stored at the Tooele Army Depot. The remaining 244 weapons were distributed as follows:¹⁶

White Sands Missile Range	8
Redstone Arsenal (Explosive Ordnance Disposal--EOD)	12
Ft Bliss, Tex (Advanced Individual Training--AIT)	170
Ft Riley, Kansas (Unit Training)	4
Ft Bragg, N. C. (Unit Training--Brass Key)	7
Ft Carson, Colorado (Unit Training)	23
CONUS Service School (Inert Weapons)	20

(U) The stratification of Army REDEYE weapons for the FY 1966-73 period and for the succeeding six fiscal years is presented in Table 8.

~~CONFIDENTIAL~~

Regraded _____, by Authority of _____
_____, by _____, on _____

¹⁵ ADSIMO Rept, REDEYE Distr Planning Info, 30 Jun 73, pp. 2, 4-6. Hist Div File.

¹⁶ *Ibid.*, pp. 1, 3.

~~SECRET~~

~~CONFIDENTIAL~~

UNCLASSIFIED

TABLE 8—(U) Stratification of Army REDEYE Weapons - FY 1966-79 (U)

<u>FISCAL YEAR</u>	<u>1966-73</u>	<u>1974</u>	<u>1975</u>	<u>1976</u>	<u>1977</u>	<u>1978</u>	<u>1979</u>	<u>TOTAL</u>
ACQUIRED ASSETS.....	20,896*							20,896*
LOSSES:								
USMC PAT.....	76							76
FRG PAT.....	21							21
Army PAT.....	512							512
Army Aviation Comd Tests...		38						38
USAF Tests.....	7							7
Army Tests.....	93							93
Inerts.....	47	20						67
Army Air Defense Board.....		5						5
New Equip Tng Firings.....	24							24
Unrepairables.....	142	5						147
EOD Demolition.....	23	5	5					33
Unit Training--Brass Key...	11	8	8	8	8	8	8	59
Contract Maintenance.....	10							10
Depot Maintenance.....	2	10	24	24	24	20	22	126
Shelf Life.....	130	10						140
Range Verification.....	2							2
AIT Ft Bliss, Tex.....	1,922	100	100	100	100	100	100	2,522
Unit Training USAREUR.....	245	125	125	125	125	125	125	995
Unit Training CONUS.....	207	166	182	182	182	182	182	1,283
Unit Training Korea.....	46	34	7	7	7	7	7	115
Unit Training Hawaii.....	13	19	14	14	14	14	14	102
Unit Training USARAL.....	19	7	7	7	7	7	7	61
Unit Training USARSO.....		7	7	7	7	7	7	42
Demonstrations.....	13							13
TOTAL LOSSES.....	3,565	559	479	474	474	470	472	6,493
YEAR END ASSETS.....	17,331	16,772	16,293	15,819	15,345	14,875	14,403	

*Includes the original Army allocation of 20,615 production units, plus 76 units from USMC for Production Acceptance Test (PAT) and 205 units picked up in the DA team inventory.

SOURCE: ADSIMO Rept, REDEYE Distr Planning Info, 30 Jun 73, p. 1.

UNCLASSIFIED

~~CONFIDENTIAL~~

197

UNCLASSIFIED

~~CONFIDENTIAL~~

~~CONFIDENTIAL~~

Regraded _____ by Authority of _____
by _____ on _____

~~UNCLASSIFIED~~
~~CONFIDENTIAL~~

CHAPTER IX

~~(S)~~ THE REDEYE IMPROVEMENT PROGRAM (U)

~~(S)~~ Although the basic REDEYE system fulfilled a critical gap in forward area, low-altitude air defense, its performance capabilities fell considerably short of the requirements set forth in the original MC's. In May 1961, it will be recalled, the users agreed to accept, on an interim basis, a weapon system which would not fully meet all requirements of the MC's, but which would have effective performance capabilities within the limits of the modified MC's. The waived requirements were primarily in the areas of engagement aspect and target velocity. The basic REDEYE was restricted by its seeker to engagements where the heat-radiating metal parts of the aircraft were visible to the missile seeker, thereby limiting engagements against jet aircraft to tail chase or outgoing trajectories. In addition, the basic REDEYE was limited, by its propulsion system, to the engagement of aircraft flying at about 400 knots, some 200 knots less than specified in the original MC's. To cope with the infrared countermeasure (IRCM) and 660-knot fighter/bomber threats postulated for the 1970 decade, a vastly improved man-portable weapon system was required. The Advanced Sensor Development Program, begun in 1965, paved the way for the improved REDEYE II (STINGER) weapon system, which was selected for development in 1971 as a replacement for the basic REDEYE.¹

¹(1) MICOM Rept No. RF-IPR-71-1, 16-17 Feb 71, subj: MANPADS Sp IPR, pp. 14 & 4-3 thru 4-6. (2) MICOM Rept, 2 Sep 71, subj: Mins of REDEYE II Sys Dev Plan IPR, p. 52. Both in STINGER Proj Ofc File. (3) Also see above, pp. 84-87, 112, 146-47.

~~CONFIDENTIAL~~
~~UNCLASSIFIED~~

UNCLASSIFIED

~~CONFIDENTIAL~~

Advanced Sensor Development Program

(S) The Army Missile Command initiated the Advanced Sensor Development Program (ASDP) early in FY 1966, with participation of the U. S. Marine Corps in the form of financial assistance. The Electro-Dynamics Division of General Dynamics/Pomona performed the research, component design, and test effort in five phases under separate contracts. The primary objective of the program was to develop an improved REDEYE system that would eliminate the performance limitations inherent in the basic system and be capable of countering the post-1975 low-altitude aircraft and helicopter threat.

Phase I

(S) General Dynamics conducted Phase I under CPIF Contract DA-04-495-1042, which was awarded in July 1965 for \$451,087. The purpose of this initial effort was to establish the design parameters for a lead selenide (PbSe)/lead bias seeker to give the basic REDEYE an engagement capability at all aspect angles. To determine the magnitude of the lead bias requirement (i.e., the amount of guidance bias required to steer the missile off the exhaust plume and onto the aircraft structure), a number of jet aircraft were tied down and their exhaust plumes were examined using a REDEYE seeker with a PbSe detector. This effort resulted in a version of the REDEYE known as Product Improvement Program (PIP) I, which consisted of the Block III REDEYE motor with the PbSe/lead bias seeker.²

Phase II

(S) The second phase was conducted under CPFF Contract

² (1) Fact Sheet, ASDP, REDEYE PM, Status o/a 30 Jun 70. Hist Div File. (2) MICOM Rept No. RF-IPR-71-1, 16-17 Feb 71, subj: MANPADS Sp IPR, p. 11-3. STINGER Proj Ofc File.

~~CONFIDENTIAL~~

UNCLASSIFIED

UNCLASSIFIED

~~CONFIDENTIAL~~

DA-AH01-67-0473 at a cost of \$1,409,259.³ Its prime objective was to prove by flight test that a REDEYE missile with the PbSe/lead bias seeker would effectively extend system performance. The effort included a trajectory and seeker computer study, circuit design, breadboards, and PbSe/lead bias seeker design for a feasibility demonstration of the PIP I concept. Six flight tests were planned, but only four were conducted because of problems with the drone aircraft. Two of these tests ended in failure because the lead bias was not properly set. The other two were successful, one of them achieving a near miss 1.9 feet behind and 2 feet below the tailpipe of the Q2C plume augmented drone.⁴

Phase III

(●) Conducted under CPFF Contract DA-AH01-68-2060 at a cost of \$749,768, Phase III was directed toward the development of an advanced airframe/propulsion/control system for a future man-portable weapon capable of engaging aircraft at speeds up to 700 knots. The LTV's flight tested in this phase combined a dual thrust (booster/sustainer) rocket motor with an advanced airframe and the standard Block III REDEYE seeker. This configuration was known as the PIP II. The results of four flight tests, conducted at White Sands in February and March 1969, successfully demonstrated the kinematic performance of the advanced airframe and motor design and the required aerodynamically induced roll rate.⁵

³P&PD Rept, Contr Listings, 1 Apr 73, p. 129. Hist Div File.

⁴Hist Repts, REDEYE PM, FY 1967, p. 4; FY 1968, pp. 4-6. Hist Div File.

⁵(1) *Ibid.*, FY 1969, pp. 6-7. (2) P&PD Rept, Contr Listings, 1 Apr 73, p. 256. Hist Div File. (3) MICOM Rept No. RF-IPR-71-1, 16-17 Feb 71, subj: MANPADS Sp IPR, p. 11-3. (4) MICOM Rept, 2 Sep 71, subj: Mins of REDEYE II Sys Dev Plan IPR, p. 53. Both in STINGER Proj Ofc File.

~~CONFIDENTIAL~~

UNCLASSIFIED

~~UNCLASSIFIED~~

~~CONFIDENTIAL~~

Phase IV

The ASDP Phase IV effort consisted primarily of the continuation of work begun under Phases II and III. Performed at a cost of \$2,472,779 under CPFF Contract DA-AH01-69-1929, its objectives included a comprehensive target signature measurement program and further flight demonstrations of the PbSe/lead bias seeker and advanced airframe/propulsion/control system.

The target signature measurement program, conducted at Edwards Air Force Base, California, included ground-to-ground, air-to-air, and ground-to-air measurements. Target signature data sources were the QF-9, F-100, F-4, and A-7 aircraft. General Dynamics measured the ASDP seeker tracking points and used a thermal image tracker for all aircraft in the ground-to-ground and ground-to-air modes. Spectral measurements were taken in the ground-to-ground and ground-to-air modes; however, data reduction was limited to that required to support the needs of the Phase IV effort.

In the ASDP Phase II seeker program, the loss of seeker acquisition during the launch phase of two guidance test vehicles brought about a reevaluation of the seeker's tracking capability in the shock environment of the launch. During Phase IV of the program, General Dynamics resolved the launch shock problem to the degree required for flight testing the PbSe/lead bias seeker on the Block III production airframe. The contractor also refined and evaluated the seeker's physical design and functional performance. Two guidance test vehicles were flown in the program. One of these was launched against an incoming crossing QF-9 jet aircraft. The missile performed as expected with the lead bias function steering the missile off the exhaust plume and into the aircraft body 12 feet forward of the tailpipe. The other test vehicle was fired at an incoming crossing MQM 61A propeller-driven drone augmented with a small thermopot infrared source simulating

~~CONFIDENTIAL~~

UNCLASSIFIED

~~UNCLASSIFIED~~

~~CONFIDENTIAL~~

a point source such as an engine manifold or helicopter exhaust. The missile physically impacted the target near the infrared source, demonstrating that the lead bias functioned equally as well against a point source as against a jet plume source.

(6) The airframe/control/propulsion system effort continued the work begun in Phase III to provide an advanced airframe capable of engaging low altitude targets flying at speeds in excess of 600 knots. The major program objectives were to study the airframe performance by using simulation, to confirm the design of a separable ejector motor by evaluating data from a flight test program, to design and test the ejector motor/advanced airframe interface, and to evaluate by flight test the advanced airframe with ejector motor. An important part of this program was to measure the launch and flight shock and vibration environment which the advanced airframe/propulsion system would impose upon the PbSe/lead bias seeker. Tests of six eject test vehicles confirmed the adequacy of the kinematics and the ability to impart the required initial roll rate to the missile. Flight tests of two launch test vehicles confirmed the total propulsion system performance. Three control test vehicles provided data on the airframe's potential maneuverability and the propulsion system's performance during in-flight environment. All program objectives were met.⁶

Phase V

(7) General Dynamics conducted the ASDP Phase V program under Contract DA-AH01-71-0024 at a cost of \$1,850,767. Completed in December 1970, this effort consisted of additional infrared

⁶(1) P&PD Rept, Contr Listings, 1 Jul 72, p. 270. (2) Hist Rept, REDEYE PM, FY 1970, pp. 4-6. (3) Also see Ltr, DCG, MICOM, thru CG, AMC, to ASA, DA, 20 Apr 71, subj: Req for Apprl of D&F for MANPADS - REDEYE II, w incls. All in Hist Div File.

~~CONFIDENTIAL~~

UNCLASSIFIED

UNCLASSIFIED

~~CONFIDENTIAL~~

target signature data reduction, investigation of IRCM concepts and techniques, including breadboards, and test and evaluation of the hazards associated with the dual thrust rocket motor and separable ejector motor.⁷

Summary

The improved REDEYE II weapon derived from the Advanced Sensor Development Program consisted of the PbSe/lead bias seeker, the new airframe, and the dual thrust rocket motor with separable ejector. It also had an improved warhead and fuzing system designed with the help of the Army Munitions Command. The length of the REDEYE II weapon would be about 60 inches, some 10 inches longer than the basic REDEYE, and the missile weight would be about 21.3 pounds.⁸

(U) The RDTE cost of the 5-year advance development program totaled \$8.5 million.⁹ Of this sum, \$6,933,660 in Army and Marine Corps funds was expended under the aforementioned ASDP contracts with General Dynamics.

Establishment of MANPADS Requirement

(U) The urgent need for development of an advanced man-portable weapon was expressed and documented in the Technical Review of Army Air Defense Systems (TRAADS) Study approved by the Department of the Army on 1 July 1968. The Chief of Research and Development designated the task of developing a follow-on system

⁷(1) Hist Rept, ADSIMO, FY 1971, p. 5. (2) P&PD Rept, Contr Listings, 1 Apr 73, p. 16. Both in Hist Div File. (3) MICOM Rept, 2 Sep 71, subj: Mins of REDEYE II Sys Dev Plan IPR, p. 53. STINGER Proj Ofc File.

⁸(1) *Ibid.*, pp. 53-56. (2) MICOM Rept No. RF-IPR-71-1, 16-17 Feb 71, subj: MANPADS Sp IPR, p. 11-3. STINGER Proj Ofc File.

⁹Hist Rept, STINGER Proj Ofc, FY 1972, p. 2. Hist Div File.

~~CONFIDENTIAL~~

UNCLASSIFIED

~~UNCLASSIFIED~~

~~CONFIDENTIAL~~

to the basic REDEYE as the highest priority item in low altitude air defense.¹⁰ On 29 January 1970, DA approved a Qualitative Materiel Development Objective (QMDO) which outlined the requirement for such a system.¹¹

(U) The MANPADS QMDO specified a maximum intercept range capability of from 2,500 to 5,000 meters against 660-knot targets in infrared and electronic countermeasure environments. Developmental emphasis was to be placed on providing the gunner with the ability to identify enemy aircraft, preferably by visual means. The weight of the new system was limited to about 30 pounds, and the equipment required to complete an engagement, including communications equipment, was to be transportable by two men.¹²

(U) During the MANPADS Special IPR held at Redstone Arsenal, Alabama, on 16-17 February 1971, the REDEYE II weapon was evaluated in competition with six other weapons, including the PIP I, PIP II, a British system known as the BLOWPIPE, and three system concepts resulting from separate MANPADS studies. This review resulted in a recommendation for the immediate development of the REDEYE II with IFF and night vision devices, as a replacement for the basic REDEYE system.¹³

Advent of the STINGER Project

(U) In April 1971, a special REDEYE II Task Team was formed

¹⁰ Ltr, DCG, MICOM, thru CG, AMC, to ASA, DA, 20 Apr 71, subj: Req for Apprl of D&F for MANPADS - REDEYE II, w incls. Hist Div File.

¹¹ Hist Rept, STINGER Proj Ofc, FY 1972, p. 1. Hist Div File.

¹² MICOM Rept No. RF-IPR-71-1, 16-17 Feb 71, subj: MANPADS Sp IPR, pp. 4-5 - 4-6. STINGER Proj Ofc File.

¹³ (1) *Ibid.*, pp. 12 thru 15 & 11-3. (2) Ltr, DCG, MICOM, thru CG, AMC, to ASA, DA, 20 Apr 71, subj: Req for Apprl of D&F for MANPADS - REDEYE II, w incls. Hist Div File.

~~CONFIDENTIAL~~

UNCLASSIFIED

BASIC REDEYE

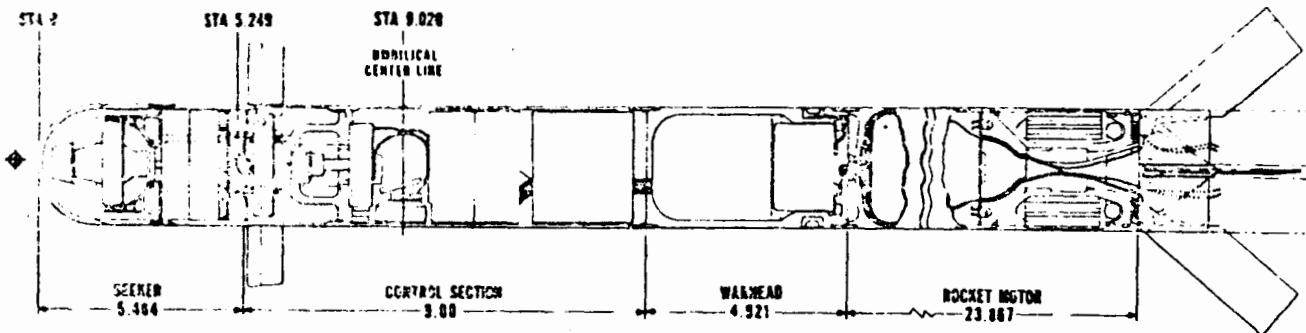

REDEYE II

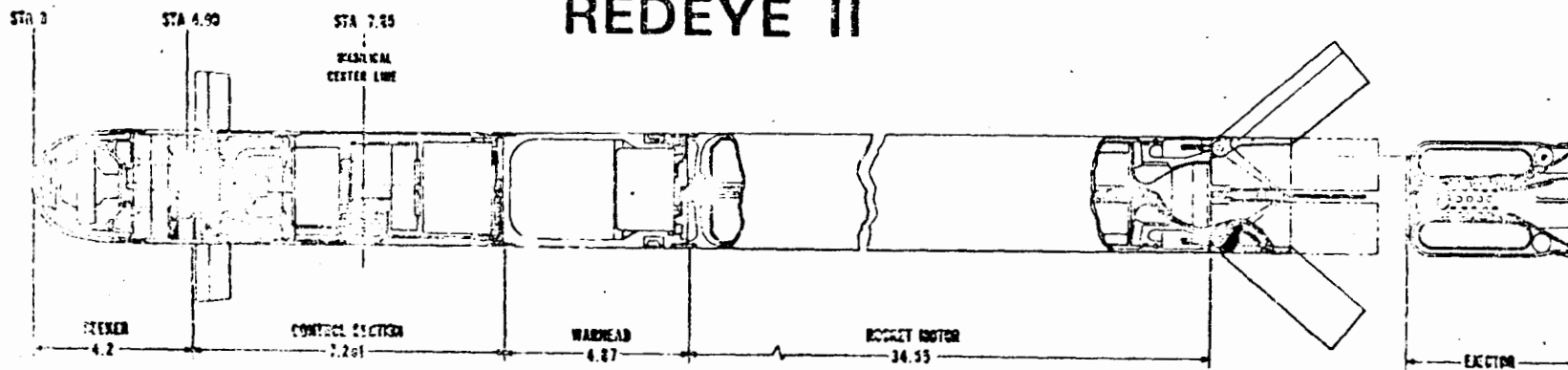

UNCLASSIFIED

~~CONFIDENTIAL~~

205

~~CONFIDENTIAL~~

UNCLASSIFIED

~~UNCLASSIFIED~~

~~CONFIDENTIAL~~

at MICOM. The REDEYE II System Development Plan IPR was held at the Missile Command in August 1971, and the XFIM-92A (REDEYE II) Management Office (Provisional) was formed in October 1971. This was followed by creation of the AMC Project Manager for REDEYE II at MICOM effective 5 January 1972, and redesignation of the weapon system as the STINGER on 10 March 1972.

☛) The contract for engineering development of the STINGER system was awarded to General Dynamics on 27 June 1972. The projected RDTE cost was \$83,287,000 for the FY 1972-76 period. This included a negotiated prime contract cost of \$46,892,000. The remainder of the projected cost covered GFE and support services for the total engineering development effort. The STINGER weapon system was scheduled for initial deployment during the first quarter of FY 1978. It was to replace the basic REDEYE system on a one-for-one basis.¹⁴

¹⁴ Hist Rept, STINGER Proj Ofc, FY 1972, w incl. Hist Div File.

~~CONFIDENTIAL~~

UNCLASSIFIED

UNCLASSIFIED

~~CONFIDENTIAL~~

CHAPTER X

~~(S)~~ CONCLUSION (U)

(U) Despite the small size of the REDEYE weapon and the simplicity of its operation, the development task proved to be an exceedingly difficult one. Contrary to the optimistic conclusions drawn from the feasibility study in 1958-59, the design initially proposed for the system required an application of technology which clearly pushed the state of the art. As a result of inadequate fiscal support and major technical problems which had been foreseen by the evaluation team as early as 1957, the RDTE cost more than tripled the original estimate of \$23.9 million and the engineering development time increased from 30 months to nearly 7 years.

~~(S)~~ From the inception of the feasibility study in FY 1958 through FY 1973, a total of \$350,506,783 was invested in the development and production of the REDEYE weapon system. The actual RDTE cost was \$82,076,000 during the 1958-70 period, in contrast to an original projection of \$23,955,000 for the 1958-61 period. The actual PEMA investment, including foreign military sales, totaled \$268,430,783 during the 1964-73 period. (See Tables 1, 5, and 9.)

(U) The month of October 1973 marked the sixth anniversary of the REDEYE as an operational weapon system. Dubbed by its developer as the world's biggest little guided missile, the man-transportable, shoulder-launched REDEYE provided the ground combat troops and installations in the battle zone with unprecedented new protection against low-level air attack. A training official at Orogrande Range near Fort Bliss, Texas,

~~CONFIDENTIAL~~

UNCLASSIFIED

summed up the vital air defense role of the REDEYE when he said:

We now have an air defense umbrella protecting our troops all the way from the rear areas to the front-line fringe areas. If an enemy aircraft is able to get past our long range and intermediate-range missiles it will practically be forced to fly in the aerial zone that Redeye was designed to defend. It would be like shooting sitting ducks. He might get one pass over our boys but he won't get a second chance. He won't be back tomorrow.¹

¹ *Army Digest*, Jun 67, p. 50.

TABLE 9— (U) REDEYE COST SUMMARY* (U)

FY	RDTE				PEMA			
	ARMY	USMC	OTHER	TOTAL	ARMY	USMC	OTHER	TOTAL
1958	.230	1.350		1.580				
1959	3.503	2.875		6.378				
1960	6.893	2.500		9.393				
1961	2.523	.825		3.348				
1962	8.328	.500		8.828				
1963	12.201	.750		12.951				
1964	15.620	.400		16.020	12.342	12.765		25.107
1965	11.112 ^a	.300		11.412	25.371	10.710		36.081
1966 ^b	3.934	.500		4.434 ^b	59.996	11.528	.123	71.647
1967	1.923	.500		2.423	27.241	11.534	.846	39.621
1968	.543	1.000		1.543	11.223	16.744	5.768	33.735
1969	.562	1.500	.880 ^c	2.942	19.679		.003	19.682
1970	.050	.774		.824	22.655		.058	22.713
1971					.952		.014	.966
1972					2.800		14.235	17.035
1973							1.843	1.843
TOTAL	67.422	13.774	.880	82.076	182.259	63.281	22.890 ^d	268.430

*In millions of dollars.

^aIncludes \$3.106 reimbursement from PEMA for 140 ET/ST rounds.

^bBeginning of ASDP. All USMC funds for 1966-70 period were allocated to the ASDP effort. Most of the Army funds for the program came from projects other than REDEYE such as TRAADS.

^c\$600,000 U. S. Air Force; \$280,000 U. S. Navy.

^dFor breakdown by source, see Table 5.

SOURCE: (1) ADSIMO Rept, REDEYE Wpn Sys R&D Funding, Feb 73. (2) Rept, PEMA REDEYE Msl Sys Maj Items, 27 Jun 73, Budget Div, Compt.

UNCLASSIFIED
CONFIDENTIAL

209

UNCLASSIFIED
CONFIDENTIAL

BLANK

- C -

C&DP----- Comptroller and Director of Programs
CDC----- Combat Developments Command
Cdr----- Commander
CG----- Commanding General
Ch----- Change
Chf----- Chief
CINCUSARPAC- Commander-in-Chief, U. S. Army, Pacific
Cir----- Circular
Civ----- Civilian
Clas----- Classification
Cmdty----- Commodity
Cmt----- Comment
CO----- Commanding Officer
CofOrd----- Chief of Ordnance
Com----- Committee
Comd----- Command
Compl----- Completion
Compt----- Comptroller
Con----- Control
Conf----- Conference
CONARC----- Continental Army Command
Contr----- Contract, Contractor
CONUS----- Continental United States
Coord----- Coordination
CPFF----- Cost-Plus-Fixed-Fee
CPIF----- Cost-Plus-Incentive-Fee
CRD----- Chief of Research & Development

- D -

DA----- Department of the Army
D&F----- Determination and Findings
DCG----- Deputy Commanding General
DCG/ADS----- Deputy Commanding General/Air Defense Systems
DCG/GM----- Deputy Commanding General/Guided Missiles
DCR----- Design Characteristics Review
DCSLOG----- Deputy Chief of Staff for Logistics
DDRE----- Director of Defense Research & Engineering
Def----- Defense
Dep----- Deputy
Dept----- Department
Dev----- Development
DF----- Disposition Form
Dir----- Director, Directorate
Distr----- Distribution
Div----- Division
Dlvr(y)----- Deliver, Delivery
Dmst(n)----- Demonstrate, Demonstration

DOD----- Department of Defense
 Dpl(mt)----- Deploy, Deployment
 DRI----- Design Release Inspection
 DRR----- Design Release Review
 DS----- Direct Support
 Dtd----- Dated
 Dy----- Duty

- E -

EGTV----- Engineering Guidance Test Vehicle
 Emerg----- Emergency
 Engr----- Engineer
 Enrg----- Engineering
 EOD----- Explosive Ordnance Disposal
 Equip----- Equipment
 Est----- Estimate
 Estb----- Establish, Establishment
 ET/ST----- Engineering Test/Service Test
 Eval----- Evaluation

- F -

FEBA----- Forward Edge of Battle Area
 FFAR----- Folding-Fin Aircraft Rocket
 FFP----- Firm-Fixed-Price
 Fgn----- Foreign
 Fld----- Field
 Flt----- Flight
 FMS----- Foreign Military Sales
 FPIF----- Fixed-Price-Incentive-Fee
 fps----- Feet Per Second
 FRG----- Federal Republic of Germany
 Ft----- Feet
 Func(1)----- Function, Functional

- G -

GD/P----- General Dynamics/Pomona
 GFE----- Government-Furnished Equipment
 GM----- Guided Missile
 GMTS----- Guided Missile Test Set
 GO----- General Order
 Govt----- Government
 Gp----- Group
 GS----- General Support
 GTV----- Guidance Test Vehicle

- H -

HB----- Heavy Barrel
 HE----- High Explosive
 Hel----- Helicopter

HERO----- Hazards of Electromagnetic Radiation to Ordnance
Hist----- History, Historical
HMX----- Cyclotetramethylenetetranitramine
HQ----- Headquarters

- I -

IFF----- Identification, Friend or Foe
Incl----- Inclosure
Ind----- Indorsement
Indus----- Industrial
Inf----- Infantry
Info----- Information
Instl----- Installation
Intcp----- Intercept
Intvw----- Interview
IPR----- In-Process Review
IR----- Infrared
IRCM----- Infrared Countermeasure

- J -

Just----- Justification

- K -

km----- Kilometer

- L -

LA----- Low Altitude
LAOD----- Los Angeles Ordnance District
Lb(s)----- Pound, Pounds
Lchr----- Launcher
Ln----- Liaison
LP----- Limited Production
Ltr----- Letter
LTV----- Launch Test Vehicle

- M -

MANPADS----- Man-Portable Air Defense System
MAP----- Military Assistance Program
Mat----- Material, Materiel
Mbr----- Member
MCA----- Military Construction, Army
MC's----- Military Characteristics
Memo----- Memorandum
MFR----- Memorandum for Record
Mgr----- Manager
Mgt----- Management
MICOM----- Army Missile Command
Mil----- Military
Mins----- Minutes

mm.----- Millimeter
 mph----- Miles Per Hour
 Mpr----- Manpower
 MRRC----- Materiel Requirements Review Committee
 Msg----- Message
 Msl----- Missile
 Msn----- Mission
 MSP----- Missile System Plan
 Mtg----- Meeting
 Mtr----- Motor
 MTS----- Moving Target Simulator

- N -

n.d.----- No Date
 NIROP----- Naval Industrial Reserve Ordnance Plant
 NOTS----- Naval Ordnance Test Station
 NTDC----- Naval Training Device Center

- O -

OCO----- Office, Chief of Ordnance
 OCRD----- Office, Chief of Research & Development
 Ofc----- Office
 Off----- Officer
 OML----- Ordnance Missile Laboratories
 Op----- Operation
 Ops----- Operations
 Op1----- Operational
 Ord----- Ordnance
 OrdC----- Ordnance Corps
 Org----- Organization, Organizational
 OTCM----- Ordnance Technical Committee Meeting

- P -

PA----- Picatinny Arsenal
 P&PD----- Procurement & Production Directorate
 Part----- Participation
 PAT----- Production Acceptance Test
 PbS----- Lead Sulfide
 PbSe----- Lead Selenide
 Pdn----- Production
 PEMA----- Procurement of Equipment & Missiles, Army
 PEMARS----- Procurement of Equipment & Missiles, Army Management
 and Accounting Reporting System
 PEMA/S----- Procurement of Equipment & Missiles, Army, in
 Support of Research & Development
 Perf----- Performance
 Pers----- Personnel
 Phys----- Physical
 PIG----- Penetration Impact Generator

PIP----- Product Improvement Program
 PM----- Project Manager
 PM2P----- Project Management Master Plan
 PMP----- Project Master Plan
 PMSO----- Project Management Staff Officer
 Ppsd----- Proposed
 Ppsl----- Proposal
 Prelim----- Preliminary
 Prepdn----- Preproduction
 Prepn----- Preparation
 Presn----- Presentation
 Prod----- Product
 Prog----- Progress
 Proj----- Project
 psi----- Pounds Per Square Inch

- Q -

QMDO----- Quantitative Materiel Development Objective
 Qual----- Qualification

- R -

RAM----- REDEYE Air-Launched Missile
 R&D----- Research and Development
 RDD----- Research and Development Division
 RDE&MSL----- Research, Development, Engineering, & Missile
 Systems Laboratory
 RDTE----- Research, Development, Test, and Evaluation
 Recm(n)----- Recommend, Recommendation
 Reg----- Regulation
 Rel----- Release
 Reorg----- Reorganize, Reorganization
 Rep----- Representative
 Rept----- Report
 Req----- Request
 Resp----- Responsibility
 Rev----- Revise, Revision
 Rg----- Range
 RHA----- Records Holding Area
 Rkt----- Rocket
 Rqr(mt)----- Require, Requirement
 RSA----- Redstone Arsenal
 Rsch----- Research
 RSIC----- Redstone Scientific Information Center
 RVN----- Republic of Vietnam

- S -

SA----- Secretary of the Army
 SAM----- Surface-to-Air Missile
 S&A----- Safety & Arming

S&MD----- Supply & Maintenance Directorate
 Scd----- Schedule
 SDR----- Small Development Requirement
 SEA----- Southeast Asia
 Sec----- Section
 SLAM----- Shoulder-Launched Antiaircraft Missile
 SN----- Serial Number
 SO----- Special Order
 SOP----- Standing Operating Procedure
 Sp----- Special
 Spt----- Support
 SS----- Summary Sheet
 SSKP----- Single-Shot Kill Probability
 Sta----- Status
 Std----- Standard
 Stmt----- Statement
 STRAF----- Strategic Army Forces
 Subj----- Subject
 Suc----- Successful
 Sum----- Summary
 Suppl----- Supplement, Supplemental
 Svc----- Service
 SXR----- Senior ARGMA Representative
 Sys----- System

- T -

TACP----- Tactical Air Control Party
 TAG----- The Adjutant General
 TCLAS----- Type Classification
 TD----- Table of Distribution
 Tech----- Technical
 TECOM----- Test & Evaluation Command
 Termn----- Termination
 Tgt----- Target
 THT----- Tracking Head Trainer
 TIR----- Technical Information Report
 Tng----- Training
 Tnr----- Trainer
 TNT----- Trinitrotoluene
 TP----- Test Plan
 TR----- Technical Report
 TRAADS----- Technical Review of Army Air Defense Systems
 Trf----- Transfer
 Trns----- Transition
 TT----- Teletype
 TTV----- Tail Test Vehicle

- U -

USAAA----- United States Army Audit Agency

USAF----- United States Air Force
USAMC----- United States Army Materiel Command
USAOMC----- United States Army Ordnance Missile Command
USARAL----- United States Army, Alaska
USAREUR----- United States Army, Europe
USARHAW----- United States Army, Hawaii
USARPAC----- United States Army, Pacific
USARSO----- United States Army, Southern Command
USATECOM----- United States Army Test & Evaluation Command
USCONARC----- United States Continental Army Command
USMC----- United States Marine Corps

- V -

Vol----- Volume

- W -

w----- With
Whd----- Warhead
Wpn----- Weapon
WSMR----- White Sands Missile Range
WSP----- Weapon System Plan

- X -

XM----- Experimental Model

INDEX

- AAI Corporation, 176n, 177-78. *Also see* Aircraft Armaments, Inc.
- Aberdeen, Maryland, 159
- Aberdeen Proving Ground, 37, 56
- Aerojet General Corporation, 13n
- Aircraft Armaments, Inc., 154, 176, 176n. *Also see* AAI Corporation.
- Aircraft, F-4, 159. *Also see* Targets (Missiles/Droned Aircraft).
- Air Defense Special Items Management Office (ADSIMO), 34-35
- Air Force. *See* U. S. Air Force.
- Alaska, 137, 144, 165, 193-95
- American military forces, 7n
- Arctic confirmatory (environmental) tests, 143-44
- Arctic Test Center, Fort Greely, Alaska, 137
- Army. *See* Department of the Army; U. S. Army.
- Army Acquisition Objective (AAO), 194-95
- Army Air Defense Board, 143
- Army Air Defense Center, 168, 178, 180
- Army Air Defense School, 162
- Army Ballistic Missile Agency (ABMA), 20, 24
- Army, Department of the. *See* Department of the Army.
- Army Electronics Command, 132, 142
- Army Equipment Development Guide (AEDG), 2-3, 5-6
- Army Field Forces, 3. *Also see* Continental Army Command (CONARC).
- Army Inventory Objective (AIO), 113
- Army Materiel Command (AMC), 26, 33, 119, 139, 143-44, 164, 168, 176, 206
- Army Materiel Control Program (AMCP), 80
- Army Materiel Plan, 123
- Army Materiel Systems Analysis Agency (AMSAA), 159-60
- Army Missile & Munitions Center & School (AMMCS), 172, 192
- Army Missile Command (MICOM), 28, 35, 116, 121, 133, 142, 199, 206.
 - Commanding General of, 33, 124
 - creation of, 26
 - production release recommended by, 119
 - trainer development and procurement, 162-63, 170, 173
 - Also see* Army Ordnance Missile Command (AOMC).
- Army Munitions Command, 132, 142, 203
- Army Ordnance Missile Command (AOMC), 59, 71, 98, 102, 107, 107n, 109
 - alternate production plan recommended by, 78, 80
 - change in name of, 26
 - Commanding General of, 20, 22-24, 46, 86, 111
 - creation of, 20
 - Deputy Commanding General for Air Defense Systems (DCG/ADS), 24n, 26-27
 - Deputy Commanding General for Ballistic Missiles, 24
 - Deputy Commanding General for Guided Missiles (DCG/GM), 24, 24n, 107

Army Ordnance Missile Command (AOMC)—Continued

Deputy Commanding General of, 98
Field Service Directorate, 24
Industrial Directorate, 24
project management by, 20-24
REDEYE development program recommended by, 46-47
reorganization of, 24, 26-27
Research & Development Directorate, 24
Also see Army Missile Command (MICOM).
Army Participation Group, Naval Training Device Center, 176
Army Rocket & Guided Missile Agency (ARGMA)
abolition of, 24, 107n
Commander of, 81-82, 84
Control Office, 22-23, 26
creation of, 20
Design Characteristics Review held at, 60
Field Service Operations, 23-24
Industrial Operations, 23-24
Ordnance Missile Laboratories, 37
project management, direction, execution, and supervision by,
20-24, 36, 56, 78-82, 98
Research & Development Operations, 22, 87
Senior Representative (SXR), 22
Army rocket and guided missile programs, 20
Army Test & Evaluation Command (TECOM), 137, 164, 177
Army Training Center, Fort Bliss, Texas, 190
Assistant Chief of Staff for Force Development (ACSFOR), DA,
143, 145, 168, 172, 192-94
Assistant Secretary of the Army (Logistics), 17
Assistant Secretary of the Army, Research & Development, 115
Atlantic Research Corporation (ARC), 56, 66-67, 91, 141, 153-54
Australia, 155, 170, 172-73

Ballistic Research Laboratories, 24
Battery E, 2d Air Defense Guided Missile Group, 1st Training
Brigade, 190
Bennett, COL Hal C., Jr., 35
BLOWPIPE missile, 204
Booster (ejector) motor. *See under* Propulsion System.
Bureau of Ordnance, Department of the Navy, 56

Camp Lejeune, North Carolina, 71
Camp Pendleton, California, 37, 71
Canal Zone (Panama), 137, 195
Cassegrainian telescope, 40, 40n
Cassegrain, N., 40n
Charlton, Ernest K., 28-29, 32

Chief of Ordnance, 20, 24, 45, 47, 56, 80, 82, 87, 96, 102. *Also see* Office, Chief of Ordnance; Ordnance Corps.
 Chief of Research & Development, DA, 47, 96, 115, 121, 170, 203.
Also see Office, Chief of Research & Development.
 China Lake, California, 7n, 36, 56
 Classification. *See* Type Classification of REDEYE System.
 Claterbos, MAJ (LTC) Henry L., 23-24, 87, 94
 Cockeysville, Maryland, 177
 Cockrell, Charles A., 19, 19n, 22-23
 Combat Development Experimentation Center, Fort Ord, California, 73
 Combat Development Objectives Guide, 14-15
 Combat Developments Command (CDC), 143-44
 Congress, 27, 127-28
 Container, shipping & storage
 M585 (XM-585)(UNIPAK), 145, 153-54
 XM-547 (TRIPAK), 124-25
 XM-547E1 (TRIPAK), 129, 132-33
 XM-571 (MONOPAK), 133, 140, 142, 154, 172
 XM-585 (UNIPAK), 140, 142
 Continental Army Command (CONARC), 3n, 46, 71, 80, 80n, 82, 86-87, 143, 155, 162, 165, 168, 178, 192-95. *Also see* Army Field Forces.
 Continental United States (CONUS), 4, 165, 175, 180, 192-96
 Convair Division of General Dynamics. *See* General Dynamics/Pomona.
 Convair/Pomona Division of General Dynamics. *See* General Dynamics/Pomona.
 Covert, COL John R. M., 32

Daly, LTC R. C., 112
 Defense Department. *See* Department of Defense.
 Denmark, 154-55, 173
 Dennis, COL Norman T., 27-28, 28n
 Department of Defense (DOD), 112, 115, 127
 Department of the Army (DA), 20, 118, 128, 139, 141, 153, 170, 178, 195
 advanced REDEYE QMDO approved by, 204
 General Staff, 50, 80n, 82, 84, 87, 111-12, 115-16, 120, 122, 127
 Materiel Requirements Review Committee (MRRC), 82, 84, 96
 special REDEYE firings directed by, 104-105, 108n
 TRAADS Study approved by, 203
 Department of the Navy
 Bureau of Ordnance, 56
 contractor-operated facilities, 17, 55-56, 122
 missile development, 6, 36
 Deployment
 concepts and missions, 182-84
 of first REDEYE teams, 32, 55, 113, 115, 182, 192-94
 lack of equipment for, 138-39, 193

Deployment—Continued

implementation of Army plans for, 192-96
organization, 183, 185-89
personnel training. *See* Training Program.
Deputy Chief of Staff for Logistics (DCSLOG), DA, 82, 112, 124
Deputy Commanding General for Air Defense Systems (DCG/ADS), AOMC,
24n, 26-27
Deputy Commanding General for Ballistic Missiles, AOMC, 24
Deputy Commanding General for Guided Missiles (DCG/GM), AOMC, 24,
24n, 107
Development Program. *See* Research & Development Program.
Diamond Ordnance Fuze Laboratories, 64
Directorate for Research, Development, & Engineering, MICOM, 34
Systems Engineering & Integration Office, 34
Directorate for Research, Development, Engineering, & Missile
Systems Laboratory (RDE&MSL), 35
Antiballistic Missile Concepts Studies Office, 16n
Systems Engineering & Integration Office, 35
Director of Defense Research & Engineering (DDRE) Ad Hoc Group, 112
Dongieux, 1LT Francis M., Jr., 103
DuVall, Francis W., 15, 16n

Eagle-Picher Company, 64

Edens, Asa, 32

Edwards Air Force Base, California, 201

Eglin Air Force Base, 159

Electronics Corporation of America, 100

Engineering Test/Service Test (ET/ST) Program, 121, 126, 128,
136-39, 143, 155

Eureka-Williams Company, 40, 64

Europe, 165, 192-95

Federal Republic of Germany (FRG), 154-55, 173. *Also see* Germany.

Finthen, Germany, 181

1st Training Brigade, Army Training Center, 190

Flares, tracking, for REDEYE targets

T-121, 43n

T-131, 88

702A, 76, 88

Folding Fin Aircraft Rocket (FFAR), 2.75-inch, 8

use of, in REDEYE feasibility tests, 13, 13n, 36, 39-40

Foreign Military Sales (FMS), 153-55, 158, 172-73, 207

Fort Benning, Georgia, 137, 168, 195

Fort Bliss, Texas, 137, 139, 168, 177-78, 180, 190, 194-96, 207

Fort Bragg, North Carolina, 102, 137, 178, 180, 195-96

Fort Campbell, Kentucky, 139, 190, 195

Fort Carson, Colorado, 180-81, 195-96

Fort Clayton, Canal Zone, 137

Fort Greely, Alaska, 137, 144
Fort Hood, Texas, 180-81, 195
Fort Knox, Kentucky, 137, 168, 195
Fort Lewis, Washington, 195
Fort Meade, Maryland, 195
Fort Ord, California, 73
Fort Riley, Kansas, 180-81, 195-96
Fort Sill, Oklahoma, 137, 195
Fort Stewart, Georgia, 137
Funding Program
 appropriations
 MCA, 180
 OMA, 47, 49
 PEMA, 46-47, 49, 51, 53, 78, 83, 111, 123-24, 127-29, 131-32,
 139, 141-42, 153-55, 157-58, 178, 207, 209
 RDTE, 16-18, 36-37, 46-47, 49-50, 50n, 51, 55, 57, 59, 80-81,
 83, 86, 99, 106-108, 114-17, 121, 126, 128, 131, 140,
 164, 170, 176-77, 199-203, 207, 209
 cost increases, 18, 27n, 47, 54-55, 59, 78, 80-81, 86, 99,
 107-108, 111, 115-17, 121-24, 139, 207
 Foreign Military Sales (FMS), 154-55, 158, 207
 original cost estimates, 14, 18, 27n, 47, 49, 114, 207
 shortages and delays, 46-47, 50-51, 54-55, 99-100, 108, 114,
 116-17, 127, 139, 207
 weapon system cost summary, 207-209
Fuze. *See under* Warhead/Fuzing System.

General Dynamics/Pomona (GD/P)
 contracts for REDEYE and MAULER development, 54
 and development
 of the Basic REDEYE System, 18, 50, 54-56, 59-60, 64, 71,
 73-74, 77, 84, 88-89, 92-93, 99, 101, 107, 108n,
 109, 113, 115, 117-19, 169
 of the Improved REDEYE (STINGER) System, 199, 201-203, 206
 establishment of resident office at, 22
 experience of, as Navy missile development contractor, 17
 feasibility study of the Helicopter RAM System, 159
 name of, 50n
 Navy-owned facilities operated by, 17, 55-56
 performance criticized, 54
 preliminary design studies by, 6-7, 13, 16, 66
 product improvement effort, 126, 130
 production
 of the REDEYE system, 55, 123, 128-29, 131-32, 138, 141,
 153-54, 156
 of training equipment, 165, 170, 172
 proposed REDEYE system presented by, 8, 15
 REDEYE development plan formulated by, 13, 46-47

General Dynamics/Pomona (GD/P)—Continued

- REDEYE feasibility study and demonstration by, 17, 36, 38, 42, 66
- REDEYE field office at, 32
- General Electric Company, 7n
- General Plastics Corporation, 142, 153-54
- Germany, 180-81, 195. *Also see* Federal Republic of Germany.
- Gober, Lewis L., 26-27, 28n
- Ground support equipment
 - Guided Missile Test Set, 93-94, 124, 128, 129n, 192
 - AN/TSM-54 (Block II), 111, 125, 128, 129n, 130, 140
 - AN/TSM-82 (Block III), 129n, 133, 140, 145, 157
 - Guided Missile Test Set Test Equipment, 145, 157
 - REDEYE Maintenance Shelter, 157
 - Type IV Test Equipment, 109
 - Weapon Surveillance Test Equipment, 157
- Guidance & Control System, 13, 36, 39-43, 62-63, 77, 84, 90, 92, 100-102, 104-107, 110, 112, 117
 - seeker, infrared, 7n, 7-8, 16, 36, 39-42, 56, 60, 62-63, 76-77, 79, 81, 86, 89-90, 92, 98, 100-101, 106-107, 110, 112, 117, 119, 126, 130
 - indium arsenide detector cell, 110, 119, 126
 - lead selenide (PbSe) detector cell, 159-60
 - lead selenide/lead bias, 199-203
 - lead sulfide (PbS) detector cell, 41, 62, 86, 107, 110, 119, 125-26, 130
 - Mod 60, 125-26, 130
 - Mod 60A, 126-27, 129-30, 133, 136
- Guns, machine. *See* Machine guns.

- Halliburton Enterprises, 133, 142
- Hawaii, 165, 180-81, 194-95
- HAWK missile, 3, 3n, 23, 29n, 45, 86, 183
- Helicopter REDEYE Air-Launched Missile (RAM) Program, 159-60
- Helicopters. *See under* Targets.
- Hinrichs, MG J. H., 47, 50. *Also see* Chief of Ordnance.
- Hirshorn, COL B. J. Leon, 24, 26
- Holloman Air Force Base, 159
- Honeywell, Inc., 163-64, 167
- Huddleston, CPT Dale, 94
- Hughes Aircraft Company, 113, 119, 126
- Human Engineering Laboratories, 24, 37

- Identification, Friend or Foe (IFF), 87, 87n, 127, 185, 204
- Improvement Program. *See* REDEYE Improvement Program.
- Industrial Program
 - advance production (preproduction) engineering, 109, 111, 114-15, 123

Industrial Program—Continued

delays in, 27n, 28, 51, 55, 78-83, 98, 107, 109, 112-15, 118, 121-22, 137-38

engineering services support, 47, 51, 79-80, 82-83, 109, 111, 121, 123, 129, 131, 141, 153-54

funds for. *See under* Funding Program.

Navy-owned facilities for, 17, 55-56, 122

original contractor proposal for, 14

procurement and production, 28, 47, 49, 51, 53, 55, 57, 77-79, 82-83, 89, 92-93, 99, 108, 108n, 109, 111, 113-15, 118-161

for Air Force and Navy applications, 157, 159-61

of Block I (XM-41) systems, 121, 123-25, 129, 133, 136-37, 155-56,

of Block II (XM-41E1) systems, 121, 127-29, 129n, 130-33, 136-40, 145, 155-56

of Block III (XM-41E2) systems, 121, 130-45, 155-56

of Standard M41 (XM-41E2) systems, 121, 153-57

summary, 155-57

product improvements (engineering design changes), 116, 121, 126-27, 129-33, 136-37

production base line, 122-23

release for limited production, 118-20

risks involved in, 57, 119, 121

transition from R&D to production, 78, 115-120

type classification

as Limited Production (LP), 78, 111, 111n, 119-21, 128, 141, 145

as Standard A, 121, 141, 143-45

Infrared Industries, 100

Jet Propulsion Laboratory, 20

Keller, MAJ F. C., 23

Kennedy, President John F., 103

Korea, 139, 165, 180-81, 192-95

LANCER system proposal, 15

Land Combat Special Items Management Office (LCSIMO), 35

Launcher/Gripstock Assembly, 7-8, 60, 95, 97, 117, 132

detachable and unitized designs of, 69, 71

proof tests of, 93-94

sight for

XM-59 optical (telescopic), 129

XM-62 open, 132-33, 143-44

Standard M171 (XM-171), 145

XM-147 (Block I), 124-25, 129, 134

Launcher/Gripstock Assembly—Continued

XM-147E1 (Block II), 129, 134

XM-171 (Block III), 133-34

London, England, 4

Los Angeles Ordnance District, 17n

Machine guns

.50-caliber, 1, 3-5, 15, 54, 78, 182

.60-caliber, 2, 4

20-mm., 4

40-mm., 5

37-mm., 2

T220, 4

T247, 4

Also see Mounts, machine gun.

Magnavox Corporation, 56, 64

Management structure. *See* Project Management.

Man-Portable Air Defense System (MANPADS), 203-204

Marine Corps. *See* U. S. Marine Corps.

Materiel Requirements Review Committee (MRRC), DA, 82, 84, 96

MAULER missile, 22-27, 28n, 43, 45, 54, 86

MAULER-REDEYE Project Office, 24-26

McGraw, MAJ Thomas F., Jr., 22

McNamara, Robert S., 103. *Also see* Secretary of Defense.

Medaris, MG John B., 20

Military Assistance Program, 123

Military Characteristics (MC's), 47, 55, 114-15, 118-19

compromise in, 54, 84-87, 198

difficulties in fulfillment of, 28, 63, 71, 98, 112-13

establishment of, 43-45

versus M41 REDEYE capabilities, 147, 198

Miniature Precision Bearing Company, 138

Missile, Intercept-Aerial, REDEYE

FIM 43C, 145

XFIM 43A (Block I), 124, 130, 136-37

XFIM 43B (Block II), 128-30, 136-37

XFIM 43C (Block III), 130, 133, 135

Also see REDEYE Weapon System.

MONOPAK Shipping & Storage Container, XM-571, 133, 140, 142,
154, 172

Motor. *See under* Propulsion System.

Mounts, machine gun

M-45, use of in REDEYE test program, 40, 59, 69, 73, 88, 93

M-62, 78

M-63, 15

T176, 4

T189, 4

T190, 4

Naval Industrial Reserve Ordnance Plant (NIROP), 55
Naval Ordnance Test Station (NOTS)
 Ammunition Safety Committee, 69, 95
 flight tests at, 36, 39, 41, 56-58, 73, 76, 88, 93,
 95, 110, 136
 member of REDEYE Technical Coordinating Committee, 24
 pilot round launcher used in REDEYE tests, 59
 SIDEWINDER missile developed by, 7n
 target radiation tests at, 38
Naval Training Device Center (NTDC), 162, 176
Navy REDEYE Program, 136, 157-58, 160-61. *Also see* Department
 of the Navy.
NIKE AJAX missile, 23
NIKE HERCULES missile, 23, 29n, 33-35, 45, 183
Norden Corporation, 138
Norris Thermador, 91
North American Aviation, Inc., 15, 17n

OCTOPUS Project, 4
Office, Chief of Ordnance (OCO)
 abolition of, 26
 REDEYE presentation to representatives of, 80
 Also see Chief of Ordnance; Ordnance Corps.
Office, Chief of Research & Development (OCRD), DA, 143, 162-64,
 167, 170. *Also see* Chief of Research & Development.
101st Airborne Division, 139, 190
Operational Availability Date (Ordnance Readiness Date), 14-15, 18,
 46-47, 51, 55, 58, 79, 82-83, 99, 107, 109, 111, 192
Ordnance Corps, 81. *Also see* Chief of Ordnance; Office, Chief
 of Ordnance.
Ordnance Readiness Date. *See* Operational Availability Date.
Ordnance Technical Committee, 43
Origin of the REDEYE Project, 1-18
Orogrande Range, 190, 207

Pettit, COL Morris W., 34-35
Philadelphia, Pennsylvania, 178
Philco Corporation, 7n, 56, 62-63, 77
Picatinny Arsenal, 24, 37, 51, 56, 64-66, 138
Plans and Schedules
 Army deployment plans, implementation of, 192-96
 Commodity Plan, updated, 51-53, 57
 Conditional (Provisional) Weapon System Plan, 46-48
 Development Test Plan, 57-59
 Engineering Test/Service Test (ET/ST) Plan, 121
 original contractor proposal, 13-14, 46
 target dates
 Design Characteristics Review (DCR), 57, 60

Plans and Schedules—Continued

target dates

- Design Release Inspection (DRI), 57, 60, 83-84, 96, 98-99
- Design Release Review (DRR), 84, 99, 108-109, 111
- Operational Availability Date (Ordnance Readiness Date), 14-15, 18, 46-47, 51, 55, 58, 79, 82-83, 99, 107, 109, 111
- Release to Industrial
 - final, 57, 83, 98
 - interim, 57, 78-79, 83-84, 98, 114
 - preliminary, 57, 78
- System Demonstration, 51, 57, 59, 83-84, 91, 94-99, 102, 108n, 111-13
- time and cost revisions, 18, 23, 27n, 28, 51, 54-55, 57, 77, 78-84, 86, 91, 93-95, 97-99, 102, 107-118, 121-24, 139, 207

Pomona, California, 17, 36, 122

Pomona Division of General Dynamics. *See* General Dynamics/Pomona.

PORCUPINE Project, 4

Power supply, 7-8, 40, 56, 64, 124-25, 132-33, 141

President of the United States, 27, 103

Procurement and Production. *See under* Industrial Program.

Product Improvement Program. *See under* Industrial Program.

Progress Aerospace Enterprises, Inc., 178

Project Management

- Air Defense Special Items Management Office (ADSIMO), 34-35
- AOMC/ARGMA Era, 20-24
- formation of, under Redstone Arsenal, 19-20
- manpower allocations, 23, 26, 28-29, 32-34
- MAULER-REDEYE Project Office, 24-26
- REDEYE Commodity Manager (Office), 26-28, 83, 113, 115-16, 118
- REDEYE Project Manager (Office), 28-34, 132, 137, 144, 165, 176
- REDEYE Steering Committee, 23
- REDEYE Technical Coordinating Committee, 23
- Special Items Management Office, 35-36
- structure, evolution of, 19-35
- vertical (centralized) management, criteria for, 26-27

Propulsion System

- booster (ejector) motor, 8, 13, 56, 66-69, 73-76, 88, 93-95, 97, 141
 - XM-111, for M46 Trainer, 164
- dual purpose rocket motor:
 - M115 (XM-115), 145
 - XM-110, 125
 - XM-115 (Block III), 133
- propellants
 - Arcite 386M, 67
 - Arcite 427B, 67
- sustainer motor, 8, 13, 17, 36-37, 39-40, 56, 66-69, 73-77, 83, 85, 88, 90-91, 94-95, 97, 100-101

Qualitative Materiel Development Objective (QMDO), 204
Qualitative Materiel Requirement (QMR), 14-15

Ransier, MAJ John G., 22

REDEYE. *Throughout.*

REDEYE Air-Launched Missile (RAM) Program, 157, 159-60

REDEYE Commodity Manager (Office), 26-28, 83, 113, 115-16, 118

REDEYE concept, advent of, 6-14

REDEYE Improvement Program, 2n, 28, 86-87, 112

Advanced Sensor Development Program (ASDP), 198-203

Man-Portable Air Defense System (MANPADS), establishment
of requirement for, 203-204

REDEYE II missile system, 2n, 28, 113, 113n, 198

creation of AMC Project Manager for, 206

proposal for, 203

recommendation for development of, 204

redesignation of, as the STINGER, 206

XFIM-92A Management Office (Provisional), 206

STINGER missile system, 2n, 28, 113, 113n, 195-96, 198

award of development contract for, 206

formation of project for, 204, 206

naming of, 206

projected development cost of, 206

schedule for deployment of, 206

REDEYE-MAULER Project Office, 24-26

REDEYE, naming of, 7

REDEYE Project, establishment of, 17

REDEYE Project Manager (Office), 28-34, 132, 137, 144, 165, 176

REDEYE Steering Committee, 23

REDEYE Technical Coordinating Committee, 23

REDEYE II missile. *See under* REDEYE Improvement Program.

REDEYE Weapon System

classification of

as Limited Production (LP), 78, 111, 111n, 119-21,
128, 141, 145

as Standard A, 121, 141, 143-45

cost of, 207, 209. *Also see* Funding Program.

deployment of. *See* Deployment.

development of. *See* Research & Development Program.

improvement of. *See* REDEYE Improvement Program.

military characteristics. *See* Military Characteristics (MC's).

Operational Availability Date (Ordnance Readiness Date), 14-15,
18, 46-47, 51, 55, 58, 79, 82-83, 99, 107, 109, 111

plans for replacement of, 206

procurement and production of. *See under* Industrial Program.

Standard M41 (XM-41E2), 121, 143-45, 153-57

capabilities versus MC's, 147, 198

components and characteristics, 145-52

REDEYE Weapon System—Continued

- XM-41 (Block I), 121, 123-25, 129, 133, 136-37, 155-56
- XM-41E1 (Block II), 121, 127-29, 129n, 130-33, 136-40, 145, 155-56, 192-94
- XM-41E2 (Block III), 121, 130-45, 155-56, 192-94

Redstone Arsenal

- Commander of, 19
 - creation of AOMC at, 20
 - national mission responsibilities of, 19
 - project management structure within, 18-19
 - REDEYE equipment located at, 195-96
 - reorganization of, 20
 - Research & Development Division, 19
 - system proposals evaluated by, 15-16, 16n
- Redstone Arsenal, Alabama, 172, 192, 204
- Reed, COL Arthur W., 29, 32
- Rehm, LTC William L., 32
- Republic of Vietnam (RVN), 193
- Research & Development Program
- characteristics and components
 - of Block I (XM-41) system, 124-25
 - of Block II (XM-41E1) system, 129
 - of Block III (XM-41E2) system, 129-30, 132-33, 140
 - of M41 (XM-41E2) system, 145-52
 - of proposed weapon system, 8-13
 - of tactical prototype system, 18, 60
 - of test mockup, 7-8
 - contractor structure, 55-56
 - development flight tests
 - GTV-2, 75-79, 82-83, 88-90, 92, 95-98, 102, 104-105, 110, 117
 - LTV-1, 67, 69, 73-75, 88-90, 95, 101, 103-104
 - LTV-1B, 75, 88-90, 95, 101, 110
 - plans for, 57-59
 - of tactical shoulder launcher, 93-94
 - engineering development, 22, 39, 46-47, 50-51
 - basic engineering design, 54-82
 - engineering design refinement, 83-120
 - Engineering Test/Service Test (ET/ST), 121, 126, 128, 136-39
 - 143, 155
 - establishment of project for, 17
 - evaluation of weapon system proposals, 15-16, 17n, 18
 - feasibility study and demonstration, 17-20, 22, 36-43, 43n, 45-46, 51, 57, 60, 63-64, 71
 - Guidance Test Vehicle (GTV) firings, 39-42, 43n, 60
 - Launch Test Vehicle (LTV) firings, 39-40, 46
 - Tail Test Vehicle (TTV) firings, 39-40
 - funds for. *See under* Funding Program.
 - human factors (operations) tests, 37-38, 46, 71, 73
 - Navy-owned contractor-operated facilities for, 17, 55-56

Research & Development Program—Continued

original proposal for, 8-16
plans and schedules. *See* Plans and Schedules.
preliminary design studies, 6-13, 16, 66
problems and schedule slippages, 18, 23, 27n, 28, 54-55, 67,
73-79, 81-84, 91, 93-95, 97-99, 106-115, 118, 121-22,
207
product improvement (engineering design changes), 116, 121,
126-27, 129-33, 136-37
flight tests, 126-27, 130-31, 136
supporting research, 16-17
target dates. *See under* Plans and Schedules.
target radiation tests, 38-39, 46
transition from development to production, 78, 115-20
Research, Development, Engineering & Missile Systems Laboratory
(RDE&MSL), Directorate for, 35
Antiballistic Missile Concepts Studies Office, 16n
Systems Engineering & Integration Office, 35
Research, Development, & Engineering, Directorate for, 34
Systems Engineering & Integration Office, 34
Rocket, 2.75-inch, 4. *Also see* Folding Fin Aircraft Rocket (FFAR),
2.75-inch.

San Clemente Island, 110
San Nicholas Island, 104
Schofield Barracks, Hawaii, 181
Schwabach, Germany, 181
2d Air Defense Guided Missile Group, 1st Training Brigade, 190
Secretary of Defense, 27, 103. *Also see* Department of Defense;
McNamara, Robert S.
Secretary of the Army, 33, 43, 103. *Also see* Stahr, Elvis J., Jr.
Seeker, infrared. *See under* Guidance & Control System.
Senate Appropriations Subcommittee, 127-28
Senior REDEYE Representative, 32
SERGEANT missile, 29n
Shipping & Storage Container. *See* Container, shipping & storage.
SIDEWINDER missile
development of, by the Navy, 7, 7n, 36
use of, in REDEYE seeker development, 36, 39-40, 56, 60, 101
Signal Corps, 56, 64
Sittason, Fred, 23
SLAM system proposal, 15, 17n
Southeast Asia (SEA), 128, 165, 192-93, 195
Southeast Asia Operational Requirement 81, 157
Special Acceptance Inspection Equipment (SAIE), 111
Special Items Management Office, 35-36
Sperry Gyroscope Company, 15
Stahr, Elvis J., Jr., 103. *Also see* Secretary of the Army.
Steenburn, COL Donald H., 35

STINGER antiaircraft gun, 2
STINGER missile. *See under* REDEYE Improvement Program.
Strategic Army Forces (STRAF), 165, 195
Strohm, CPT H. W., 23
Sustainer motor. *See under* Propulsion System.
Sweden, 155, 170, 172-73

Tactical Air Control Party (TACP), 182-83

Targets (Missiles/Droned Aircraft)

A3D, 38
A4D, 38
A-7, 201
FJ-4, 37
F2H, 38
F3D, 38
F-4, 201
F6F, 88, 96, 104
F9F, 37, 96
F9F-6K, 38
F-100, 201
F-102, 38
H-13 (Helicopter), 96
HUS-1 (Helicopter), 38
JD-1, 38
KD2R5, 76, 88, 97, 104, 117
L-19, 85
MQM 61A, 201
OQ-19, 43n, 85, 88
PB4Y2K, 104-105, 117
QF-9, 201
QF-9F, 117
Q2C, 200
R5D, 38
T-28, 38
TV-2, 38

TARTAR missile, 55

Technical Review of Army Air Defense Systems (TRAADS) Study, 203

Teledyne Corporation, 173

TERRIER missile, 55

MSG-3 launcher, use of in REDEYE firings, 39

Test equipment. *See under* Ground Support Equipment.

Thermoplastics, Inc., 132

Tongduchon, Korea, 181

Tooele Army Depot, 193, 195-96

Training Devices & Equipment, 114-15, 131, 138-39, 155, 195

Electronic Trainer, XM-42, 167-70, 175

Field Handling Trainer, M46 Series

design and development of, 163-64

Training Devices & Equipment—Continued

- Field Handling Trainer, M46 Series
 - M46 (XM-46) (Block I), 164-66
 - M46A1 (XM-46E1) (Block II), 164-65
 - M46A2 (XM-46E2) (Block III), 164-66
 - production and distribution of, 164-65
- Moving Target Simulator (MTS), M87 (XM-87)
 - buildings for, 178, 180-81
 - characteristics of, 176
 - design and development of, 176-77
 - operational availability of, 180-81
 - production and distribution of, 154, 178, 180-81
- Small Development Requirement for, 163, 175-76, 178
- trainers for use with, 168, 170, 175, 178
- type classification of, 177
- Requirements for, 162-63
- Simulator, missile, 37, 71
 - XM-28, 164
- Tracking Head Trainers (THT), XM-49 Series
 - M76 (XM-49E3) Training Set, 170
 - M76 (XM-76) Training Set, 167, 170, 172-74, 192
 - XM-49 (Interim) THT, 167-71
 - XM-49E1 (Block II) THT, 170-71
 - XM-49E2 (Block III) THT, 170-71
 - XM-49E3 (Improved) THT, 170
- Trainer, 3-G-84, 93, 109, 162
- Training Program, 14, 32, 55, 182, 196
 - equipment for. *See* Training Devices & Equipment.
 - gunner and controller training, 138-39, 190
 - key instructor/key operation courses, 190
 - maintenance training, 172, 192
 - new equipment training, 136, 190
 - resident training, 167, 190
 - supervisory personnel courses, 190
- TRIPAK Shipping & Storage Container
 - XM-547, 124-25
 - XM-547E1, 129, 132-33
- Tripartite Conference, 4
- Truck, 1/4-ton, M151A1, 140
- Turner, J. R., 23
- Twenty-Nine Palms, California, 37
- Type classification of REDEYE System
 - as Limited Production (LP), 78, 111, 111n, 119-21, 128, 141, 145
 - as Standard A, 121, 141, 143-45

UNIPAK Shipping & Storage Container
M585 (XM-585), 145, 153-54
XM-585, 140, 142

U. S. Air Force, 155, 158, 170
REDEYE Air-Launched Missile (RAM) Program, 157, 159
Systems Command, Aeronautical Systems Division, 159

U. S. Army, 1, 8, 15-16, 26, 37, 66, 81, 112, 127-28
Airborne Division, 185
Airmobile Division, 185
Alaska (USARAL), 165, 193-95
Armored Division, 185
deployment of the REDEYE weapon system, 192-97
disposition of REDEYE weapons acquired by, 196-97
Europe (USAREUR), 165, 192-95
Hawaii (USARHAW), 194-95
Infantry Division, 185
-Marine Corps Arctic Confirmatory Test, 143
-Marine Corps statement of MC's, 43
Mechanized Division, 185
Pacific (USARPAC), 139, 165, 192-95
REDEYE employment concept, 182
REDEYE funding support by, 17-18, 46-47, 49-50, 53-54, 114,
116, 131, 142, 154-55, 158, 203, 209
REDEYE procurement for, 53, 109, 113, 120, 122-23, 139, 153-55
Reserve and National Guard units, 173, 195
Southern Command (USARSO), 165, 193-95
training equipment requirements and allocations, 165, 172-73,
177-78, 180
training schools and centers, 163, 168, 173, 175
Also see Department of the Army (DA).

U. S. Marine Corps (USMC), 1, 8, 15, 37, 56, 66, 71, 80n, 81,
86-87, 143
-Army Arctic Confirmatory Test, 143
-Army statement of MC's, 43
officers in REDEYE project management, 22-23
REDEYE employment concept, 182
REDEYE funding support by, 16-18, 36-37, 46-47, 49-50, 53, 55,
59, 80, 114, 116, 120, 124, 129, 131, 140, 142, 158,
199, 203, 209
REDEYE procurement for, 53, 109, 120, 153, 155
training equipment allocations, 165, 170, 172-73

Vilseck, Germany, 181

War Department Equipment Board, 1
Warhead/Fuzing System, 7-8, 13, 37, 56, 88-89, 96-97, 102, 104,
124, 130, 132, 136, 141

Warhead/Fuzing System—Continued

- M221 (XM-221E2) Warhead Section, 145
- M222 (XM-222) Warhead, 145
- M814 (XM-814E1) Fuze, 145
- XM-137 (Block I) Warhead Section, 125
- XM-45 Warhead, 64-65, 125
- XM-804 Fuze, 64-65, 125
- XM-137E1 (Block II) Warhead Section, 129
- XM-45E1 Warhead, 129
- XM-804E1 Fuze, 129
- XM-221 (Block III) Warhead Section, 133, 138
- XM-222 Warhead, 133
- XM-814 Fuze, 133, 138
- Washington, D. C., 112, 168
- West Covina, California, 164
- White Sands Missile Range (WSMR), 20, 24, 56, 108n, 136, 159, 196, 200. *Also see* White Sands Proving Ground.
- White Sands Proving Ground, 20. *Also see* White Sands Missile Range.
- World War II, 1, 182

Zero Manufacturing Company, 153-54

Zierdt, COL (BG) John G., 81, 107